



PRIMAflex Installation Guide



AUGUST 2021

Contents

1. Introduction	3	4.6 Making Penetrations	8
1.1 What is PRIMAFlex?	3	4.7 Fixing the Panels	8
1.2 Benefits of PRIMAFlex	3	4.8 Vertical Joints	9
1.3 PRIMAFlex Intended Use	4	4.9 Horizontal Joints	9
1.4 Supporting Information	4	4.10 Internal and External Wall Corners	10
2. Scope of Use and Limitations	5	4.11 4.5mm & 6.0mm Panel Layout	11
2.1 Scope of Use	5	4.12 Finishing the Panels	11
2.2 Limitations	5	5. Installation Instructions	12
3. Information for Designers	6	5.1 Panels as a Cavity System	12
3.1 Skills Required	6	5.2 Panels as a Suspended Ceiling	12
3.2 Considerations When Designing	6	5.3 Panels as a Soffit & Eave Lining	13
3.3 Building Consent Application Documents	6	5.4 Panels as an External Ceiling Lining	13
4. Information for Installers	6	5.5 Panels as a Sub-Floor Enclosure	13
4.1 Skills Required	6	5.6 PRIMAFlex as a Firewall	14
4.2 Health and Safety	6	6. Certifications held by PRIMAFlex	14
4.3 Handling and Storage	6	7. Useful Links	14
4.4 General Installation	7	Notes	15
4.5 Cutting the Panels	7		

NZBN 9429000097253

PRIMAFlex Cement Board Product Details			
L x W x Thickness (mm)	Weight (kg)	IBS Product Code	GTIN
2400 x 300 x 4.5	4.5	PRIMAF04243	09421028760010
2400 x 450 x 4.5	6.8	PRIMAF04244	09421028760027
2400 x 600 x 4.5	9.0	PRIMAF04246	09421028760034
2400 x 750 x 4.5	11.3	PRIMAF04247	09421028760041
2400 x 900 x 4.5	13.5	PRIMAF04249	09421028760058
2400 x 1200 x 4.5	18.0	PRIMAF042412	09421028760065
2700 x 900 x 4.5	15.2	PRIMAF04279	09421028767750
2700 x 1200 x 4.5	20.3	PRIMAF042712	09421028760072
3000 x 900 x 4.5	16.9	PRIMAF04309	09421028767767
2400 x 1200 x 6	24.0	PRIMAF062412	09421028760119
3000 x 1200 x 6	30.0	PRIMAF063012	09421028760133
2400 x 1200 x 9	36.0	PRIMAF092412	09421028760140

Contact us for more information or to talk to our team.

www.ibs.co.nz | 0800 367 759 | info@ibs.co.nz



1. Introduction

This document is intended for designers and installers to ensure IBS PRIMAflex is specified and installed correctly.

1.1 What is PRIMAflex?

IBS PRIMAflex is a cellulose fibre cement panel. Each panel has a smooth, uniform face and is ready to be finished with a variety of paint, lightweight plaster systems or overlaid with ceramic tiles, slate, or stone composite products.

The panels are manufactured in a high-pressure chamber (called an autoclave) from high-grade cellulose pulp fibre, finely ground sand Portland cement and water. This process makes the panels strong, durable, and non-combustible. It is also moisture resistant and can help with soundproofing.

1.2 Benefits of PRIMAflex

PRIMAflex is a high performance cellulose fibre cement sheet manufactured with sand, cement, cellulose fibre and additives. It is one of the most resistant materials there is for your exterior and interior.

Key attributes and benefits

- Excellent weathering properties
- Smooth finish for paint
- Excellent acoustic performance
- Environmentally friendly materials
- Excellent strength and toughness
- Waterproofing and fireproofing
- Not prone to warping or cracking
- Good thermal and heat insulation
- Durability and long lifetime
- Low maintenance

1.3 PRIMAFlex Intended Use

Intended use for PRIMAFlex are:

- External cladding
- Internal lining - floors, ceilings and walls
- Structural flooring
- Eaves, verandahs and carports
- Fire and acoustic walls and floors
- Bracing solutions

IBS supply PRIMAFlex panels in various lengths, widths, and thicknesses for the following specified uses:

Panel Thickness	Panel Length (mm)	Panel Width (mm)	Use
4.5mm	2400	300, 450, 600, 750, 900, 1200	<ul style="list-style-type: none"> • Soffit & eave lining • External ceiling lining • Suspended ceilings
	2700	900 & 1200	
	3000	900	
6.0mm	2400	1200	<ul style="list-style-type: none"> • Soffit & eave lining • External ceiling lining • Suspended ceilings • Subfloor enclosure • Fire wall component • External cladding
	3000	1200	
9.0mm	2400	1200	<ul style="list-style-type: none"> • Soffit & eave lining • External ceiling or wall lining (using expressed joints) • Fire wall component • Substrate for schist wall applications

1.4 Supporting Information

This document must be read in conjunction with the:

- IBS PRIMAFlex pass™ (Product Assurance Supplier Statement)
- IBS PRIMAFlex Care and Maintenance
- IBS Warranty

All other information is available at www.ibs.co.nz.





2. Scope of Use and Limitations

2.1 Scope of Use

IBS supply PRIMAFlex for use within the following scope:

Location:

- In NZS3604:2011 wind zones up to and including extra high or 2.5kPa ULS.
- In all corrosion zones.
- Within 1m of a relevant boundary.

Building scope:

- On new buildings that comply with the New Zealand Building Code (NZBC) or existing buildings where the designer and installer are satisfied that the existing building is suitable for the intended building work.
- On timber or light gauge steel-framed buildings.
- On buildings with a risk score of less than 20, calculated in accordance with E2/AS1, table 2.
- On vertical and horizontal, flat surfaces, except for the tops of balustrades and parapets, which must have a minimum 50 slope.
- With aluminium and wood window joinery that is installed with vertical jambs and horizontal heads and sills.

- On a deck structure that has adequate fall to shed water.
- On flat or raking ceilings and soffits.
- In conjunction with a suspended ceiling design.
- In conjunction with a fire rated wall or ceiling design.

2.2 Limitations

- Specification and installation must be in accordance with the PRIMAFlex Design and Installation Guide.
- Where restricted building work applies (RBW), PRIMAFlex must be installed (or the installation must be supervised) by a Licenced Building Practitioner (LBP).
- PRIMAFlex must not be installed on timber framing where the moisture content is greater than 18%. We recommend using seasoned or kiln-dried timber framing.
- Proprietary suspended framing systems must be able to support the applied loads of panels. Always consult with the supplier/manufacturer for the recommended load that can be applied and the seismic requirements.
- Consult with suppliers of waterproof membranes, tile adhesive, paint and plaster that selected products are compatible with PRIMAFlex.

3. Information for Designers

3.1 Skills Required

The designer will need to have knowledge of the product and access to all the IBS technical information (see www.ibs.co.nz for details).

Where RBW provisions apply, the designer must ensure that they are able to meet their obligations.

3.2 Considerations When Designing

When specifying IBS PRIMAFlex, the designer must ensure that the project falls within the specified scope. The designer must also consider the following indicative list:

Location:

- Wind zone
- Corrosion zone
- Earthquake zone

The building work:

Compliance of the building with all relevant provisions of the NZBC, including but not limited to:

- Suitability of the existing building
- Structural framing requirements
- Other materials likely to affect the product's performance

3.3 Building Consent Application Documents

When applying for a building consent, include the following documents:

- IBS PRIMAFlex pass™ (Product Assurance Supplier Statement)
- IBS PRIMAFlex Design & Installation Guide
- IBS PRIMAFlex Care & Maintenance
- IBS Warranty.

4. Information for Installers

4.1 Skills Required

PRIMAFlex panels can be installed by a person with the appropriate skills and equipment, who has knowledge of the product and access to the relevant PRIMAFlex technical information (see www.ibs.co.nz for details).

The installer must also understand the PRIMAFlex system, the componentry to be used and the proposed finished coatings and overlays.

Where RBW provisions apply, the installer must ensure that they are able to meet their obligations.

4.2 Health and Safety

When installing PRIMAFlex take all steps to ensure your safety and the safety of others:

- Use safety glasses, ear protection, and wear appropriate clothing and footwear,
- Use all tools in accordance with the relevant instruction manuals.
- Do not cut indoors using a circular saw. Use a hand guillotine, fibre cement shears or a score and snap knife.
- Provide dust extraction if working in an enclosed space.

For further information, refer to:

- The Absolutely Essential Health and Safety Toolkit
- Worksafe New Zealand Quick Guide

IMPORTANT NOTE:

Where building work will be undertaken on existing buildings (built prior to the mid1970's) the material may contain asbestos and should be treated accordingly. In all cases the installer must seek professional advice on handling, replacement, or demolition.

4.3 Handling and Storage

- Protect the panels from rain when they are transported.
- When the panels arrive, remove the fixing straps to reduce the stress on the panels and store

them flat, above ground, on timber bearers. Keep the panels dry and cover them if they are stored outside.

- Timber should be spaced no greater than 600mm apart for 4.5mm and 6.0mm PRIMAFlex panels.
- To avoid chipping, make sure the edges and corners are protected.

4.4 General Installation

Tools you will need:

- Scoring tool and snap knife
- Circular saw with a dust extractor – angle grinders are not recommended for 4.5mm, 6.0mm and 7.5mm panels
- Hole saw
- Screw gun
- 150mm broad knife
- Hand guillotine
- Straight edge
- Tape measure

Accessories you may need:

- 40 x 2.8mm galvanised / stainless steel fibre cement nails
- Joint reinforcing tape
- Bond breaker tape
- PVC sheet and mid floor jointers
- Galvanised or aluminium flashings
- Aluminium internal and external corner angles
- Flexible acrylic sealant



4.5 Cutting the Panels

PRIMAFlex panels can be cut with common power tools such as a circular saw equipped with a diamond-tipped cutting blade. This must only be done in a well-ventilated area. Do not wet the sheet or the saw blade during cutting process. We also recommend using power tools with dust-extracting attachments.

A dust mask and safety goggles must always be worn when cutting, drilling, or grinding the sheet.



Score and snap method

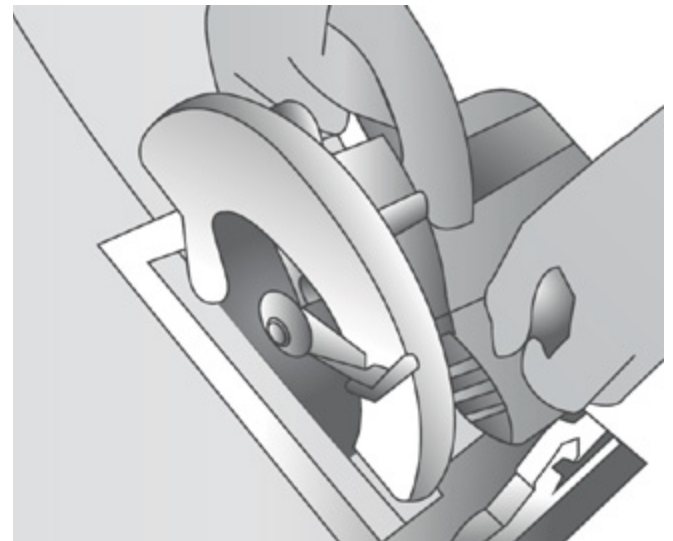

Machine cut

4.6 Making Penetrations

You can form round holes by drilling a series of smaller holes around the perimeter of the new opening. Then carefully tap out the waste piece. Trim the rough edges with rasp if required. Use a suitable high-speed heavy-duty drill bit. Cut rectangular or square openings using a circular saw.

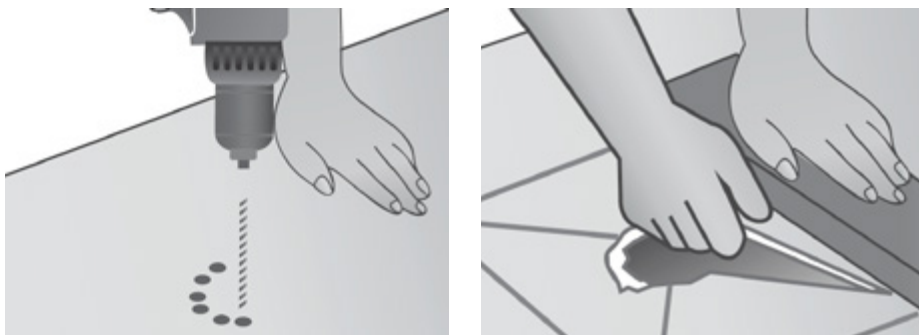

Notching and penetration

4.7 Fixing the Panels

Fasteners must be fixed at the following distances:

- 12mm from the edge
- 50mm from the corner
- 200mm centres around the perimeter
- 300mm centres elsewhere

The nails must finish flush with sheet surface.

Panels must be fixed using the following	
Fixing to timber framing	<ul style="list-style-type: none"> • 2.8mm diameter x 30mm and 40mm galvanised fibre cement nails. • Drive nail head flush with the panel surface.
Fixing to steel framing (up to 1.6mm BMT)	<ul style="list-style-type: none"> • 8 gauge x 22mm self-embedding head screws (SEH). • Screws must have a class 3 finish and be embedded 0.5mm below the sheet surface.

In areas of severe coastal environments, consult fastener manufacturers for recommendations.

If you are fixing the panels over a rigid air barrier like IBS RigidRAP, you must increase the length of the nails equal to the thickness of the rigid air barrier.



4.8 Vertical Joints

PRIMAflex panels can also be used with vertical jointing systems, including timber batten, PVC, and flexible sealant jointing. See the drawings below for details:

NOTE:

1. Self-embedding head screws should be used with 6mm thick panels above.
2. The 3mm minimum gap is for a sealed joint if required.
3. panels are fixed with standard fibre cement screws and nails.
4. All fixings shall be selected in accordance with environmental conditions and durability requirements as specified Sec.4, NZS3604:2011.

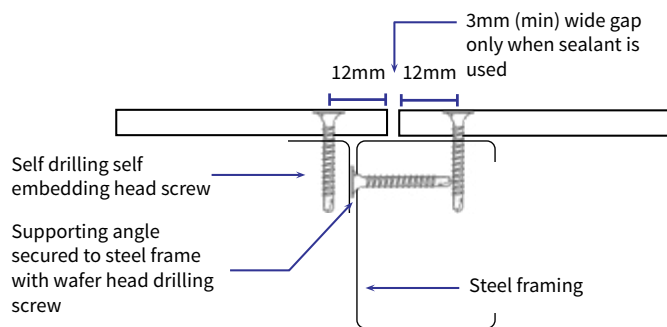

Figure 1 Typical Joint Detail

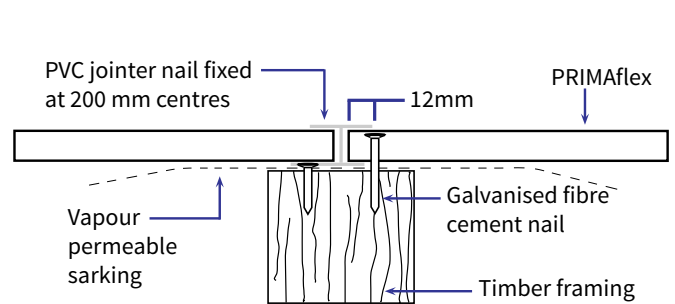

Figure 2 Typical Detail with PVC Joint

4.9 Horizontal Joints

Horizontal joints are likely to occur when a building's wall height is more than one sheet in length.

You must use exterior grade PVC or galvanised flashing for all PRIMAflex horizontal joints.

When the building height is more than one storey high, provide a horizontal control joint along the junction of the floor joist on the upper storey.

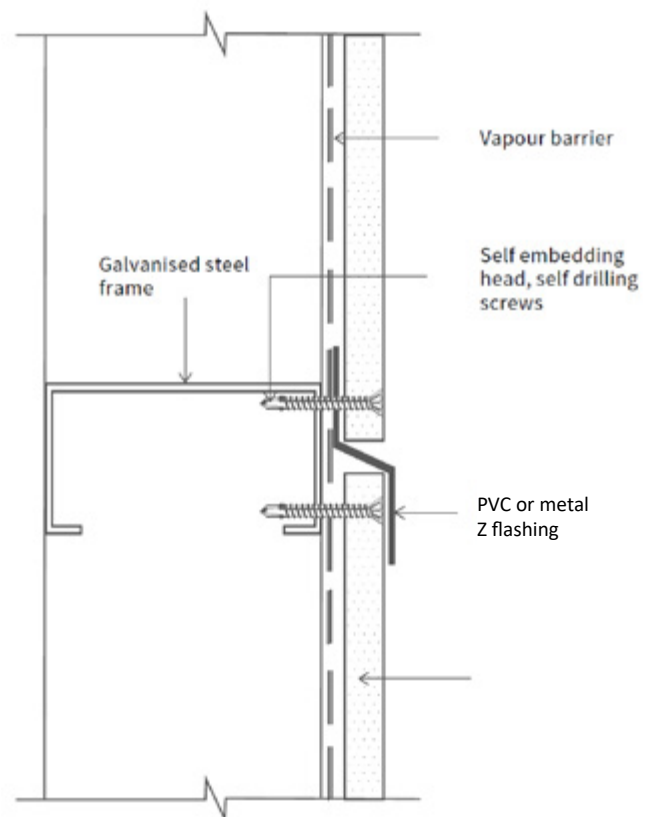

Figure 3 horizontal joints

4.10 Internal and External Wall Corners

PRIMAflex panel corner joints can be battened with treated timber or finished with proprietary metal or PVC corner moulds or back flashings.

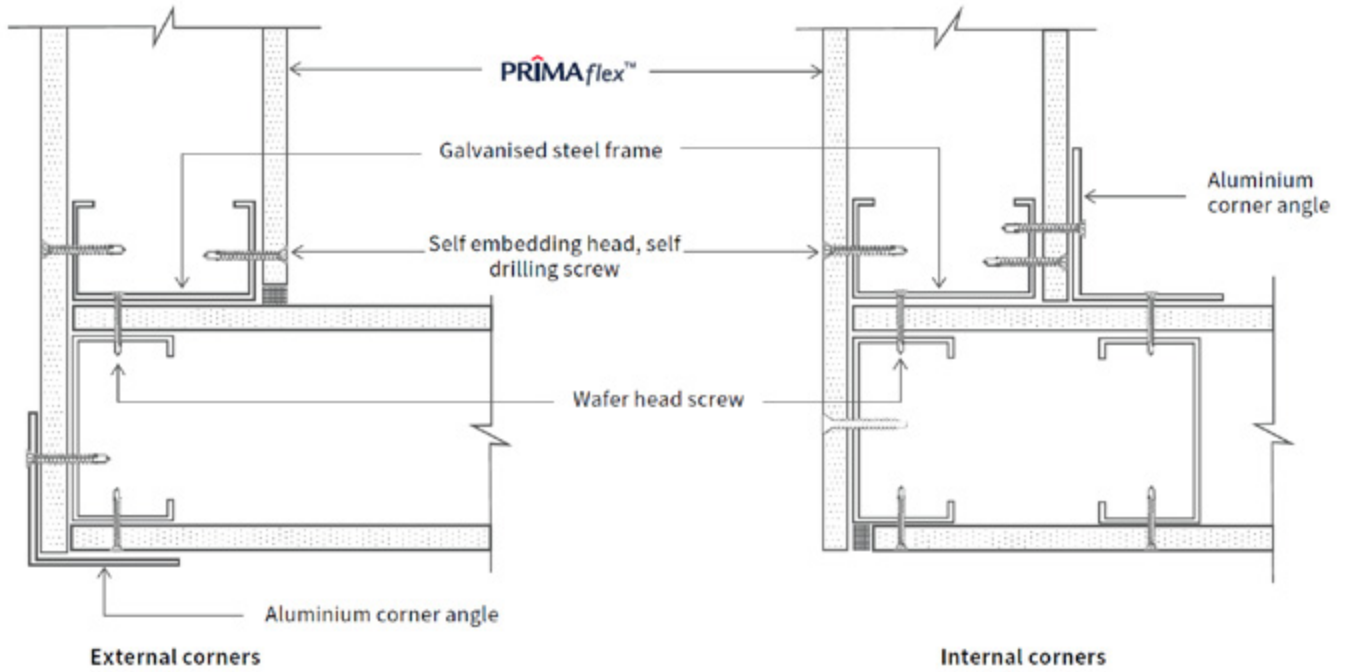

Figure 4 external/internal corners (aluminium angle trim)



4.11 4.5mm & 6.0mm Panel Layout

4.5mm & 6.00mm PRIMAflex panels can be laid parallel to – or across – the ceiling joist which ever provided the best optimisation of the panel.

Supporting framing distance for ceiling		
Support Framing Centre Distance (mm)		
Board thickness	Ceiling eaves/soffit lining	
	Joist	Trimmer
4.5mm	600	600
6.0mm	600	1220

You must use the following framing:

Horizontal timber framing support will depend on roof framing centres or ceiling joists. However, we recommend maximum spacings of 600mm centres. If you are using 4.5mm PRIMAflex panels with spans greater than 600mm, the framing should be reduced to a maximum of 480mm centres.

4.5mm & 6.00mm PRIMAflex panels are suitable for horizontal and racking soffits.

Horizontal framing fixing width:

- Timber: 40mm minimum
- Steel: 38mm minimum

Where required, the edge width can be increased by using trim packing to the side of the horizontal support.

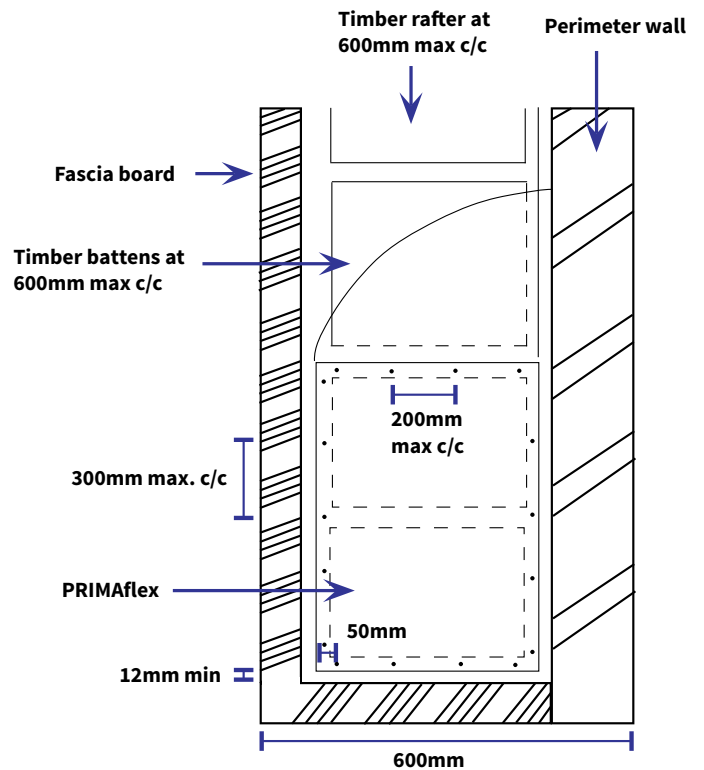

Figure 5 Ceiling board installation

4.12 Finishing the Panels

IBS recommend asking your preferred supplier about paint systems that are compatible with fibre cement panels.

Before you begin painting, waterproofing, or rendering, ensure all panel joints are sealed and/or filled using an approved exterior grade flexible acrylic sealant or filler.

Once the joints are dry remove any dirt, grease, or dust from the panel surfaces.

To clean or maintain the finish, follow any instructions from the manufacturer.

5. Installation Instructions

5.1 Panels as a Cavity System

Installing 6.0mm & 9.0mm Panels As A Cavity System

Check the substrate

- Before you install the panels, check the framing structure is square and true.
- The framing must also fully support all sheet edges. It must be rigid and not rely on the cladding sheet for stability.
- All timber framing sizes must be as specified in this installation guide. They must also comply with the NZBC or be suitable for the intended building work.
- Timber framing must durable and be in accordance with framing manufacturer's specification.
- Lightweight steel framing must be in accordance with Nash Design and NZS 3404 Steel Structures Standard.
- Install a thermal break on all external steel wall framing where PRIMAflex panels are used on the external envelope.

Install building wrap

Building underlay or a rigid air barrier such as RigidRAP must be provided to meet the requirements of the NZBC. The building underlay installation must comply with the NZBC. It must be fixed in accordance with the underlay manufacturer's requirements.

Install the cavity battens

For a cavity construction method, use the following framing:

- Studs spacing: 600mm centres maximum
- Nog or dwang spacing: 800mm centres maximum.
- Stud and face noggings or dwang edge width:
- Timber: 40mm minimum
- Steel: 38mm minimum

Where required, the edge width can be increased by using trim-packing to the side of the studs and noggings or dwangs. An extra stud is required in internal corners.

The timber battens you use must be minimum of H3.1 and treated in accordance with NZS 3640

(Chemical preservation of rough and sawn timber).

The cavity battens must also be:

- A minimum 18mm thick x 40mm wide
- At least as wide as the width of studs.

When studs are at 600mm centres the battens must be provided at 300mm centres.

The battens must be fixed by the panel fixings to the structural framing through the building underlay. Until you fix the panels, the battens only need to be tacked into their correct place on the framing. You will not require an intermediate batten between studs if the studs are spaced at maximum 400mm centres or you are using rigid sheathing instead of building underlay.

Install the flashings

Before you install the PRIMAflex panels, any wall openings, penetrations, intersections, connections, windowsills, heads, and jambs must be flashed in accordance with E2/AS1.

Penetrations through the building wrap or rigid barrier must be sealed or flashed at the junctions. Lap all flashings so that water tracks down to the exterior on the face of underlay. The flashing you install must comply with the durability requirements of the NZBC.

6mm and 9.0mm panel layout

PRIMAflex 6mm and 9mm cavity system panels are normally installed vertically. This minimises the number of horizontal sheet joints and all the panel edges must be supported by the framing. If installing horizontally the battens are required to be either castellated or Cavibat™ to ensure adequate ventilation and drainage.

5.2 Panels as a Suspended Ceiling

Installing 4.5mm & 6mm Panels as a Suspended Ceiling

Where PRIMAflex is specified as part of a suspended ceiling, it must be incorporated into a proprietary suspended metal framing system. Typically, the system is prefabricated using pre-finished aluminium or light gauge galvanised steel.

The framing system is made up of "T", cross "T" and

a wall perimeter angle. Once suspended from the structural floor above using hangers, the floor will support the PRIMAFlex panels.

The PRIMAFlex suspended ceiling system is suitable for use in commercial and office buildings because it provides a ceiling void for building services. PRIMAFlex must be installed in accordance with the supplier's instructions.

Once the suspended ceiling system is erected, cut the panels to the size of the support grid (with 3mm clearance), pre-paint them and then lift into place. No mechanical fixing is required.

5.3 Panels as a Soffit & Eave Lining

Installing 4.5mm & 6mm Panels as a Soffit & Eave Lining

Eave linings are normally installed before a wall cladding system.

Where 4.5mm & 6.0mm PRIMAFlex panels are specified as a soffit or eave lining the selection of the correct thickness will be dependent on the framing support. The maximum recommended horizontal support for 4.5mm PRIMAFlex is 450mm and 600mm for 6.0mm PRIMAFlex.

Typically, the fascia will have a preformed groove to accommodate the eave material and the junction of the eave can be supported by the cladding system or the use of a timber finishing line.

PVC or timber battens can be used where sheet joints are required.

Fixings required are: 40 x 2.8mm galvanised / stainless steel fibre cement nails or surefix countersunk screws.

Nails must be hammered flush with the PRIMAFlex panel surface. When screwed, countersink 0.5mm below the surface. Screws are not recommended where 4.5mm PRIMAFlex panels are used.

After the installation of PRIMAFlex, holes should be filled, primed, and painted.

5.4 Panels as an External Ceiling Lining

Installing 4.5mm & 6mm Panels as an External Ceiling Lining

Where 4.5mm & 6.0mm PRIMAFlex panels are specified as a ceiling lining it must be supported by timber or light weight steel framing at maximum 450 centres for 4.5mm panels and 600mm centres for 6.0mm panels.

PRIMAFlex can be installed with PVC jointers mid span between ceiling joists provided the sheet spans do not exceed 600mm.

Fixings required are: 40 x 2.8mm galvanised / stainless steel fibre cement nails or surefix countersunk screws.

Nails must be hammered flush with the PRIMAFlex panel surface. Screws must be countersunk 0.5mm below the surface. Screws are not recommended if you are using 4.5mm PRIMAFlex panels.

After installation, any holes should be filled, primed and painted.

5.5 Panels as a Sub-Floor Enclosure

Installing 6.0mm & 9.0mm Panels as a Sub-Floor Enclosure

6.0mm & 9.0mm PRIMAFlex panels are suitable for enclosing timber sub-floors. You can carry out this work to limit the under-floor air flow and improve the thermal efficiency of the building, or purely to improve how it looks.

While there is no prescribed construction method for a sub-floor enclosure, we recommend the following requirements as a minimum:

- Install horizontal treated H3.2 timber supports below the floor joist and a minimum of 150mm above ground. The supports can be attached to the sub-floor framing (ie piles, bearers and or joists).
- Place vertical timber supports at maximum centres of 600mm when fixing.
- Ensure the PRIMAFlex panels are installed clear of the ground to minimise moisture wicking.
- Ensure the sub-floor ventilation is installed in accordance with NZS3604: 2011.

5.6 PRIMAflex as a Firewall

Installing PRIMAflex as a Firewall

Because PRIMAflex panels are a non-combustible material they can be designed to be used in conjunction with a fire rated wall system that meets the performance requirements of the NZBC C2-C6 Protection from fire.

A fire wall is a full system, designed with specific components to meet the purpose of the intended use of the building and the area within or external to the building requiring protection.

6. Certifications held by PRIMAflex

- ISO 9001: 2008 Quality System (Ref-AR0430-IQNet Certification)
- ISO 14001: 2004 Environmental System (Ref-ER0642-IQNet Certification)
- BRANZ appraisal No:737 (2011)

7. Useful Links

Visit www.ibs.co.nz for further information on PRIMAflex.

Notes:



1/7 Fraser Road, Panmure, Auckland, New Zealand
0800 367 759 | info@ibs.co.nz
www.ibs.co.nz