

EXTERNAL HORIZONTALLY FIXED WALL CLADDING SYSTEM



CEDARSCREEN

BEVEL BACK

BEVEL BACK WEATHERBOARDS



Many of us are familiar with the black stained bevel back boards and crisp white joinery first seen in the early Vernon Brown houses scattered through Auckland's Eastern Suburbs. Since the 1940s this style has developed and been refined to result in a well accepted aesthetic. With new technologies and coating techniques, this durable and 'bullet proof' cladding has become well accepted as a sophisticated building methodology that is known to add value and longevity.

To introduce choice in texture to give further flexibility from an aesthetic point of view, various oil finishes are available. Different reactions to these and the subtlety of changing light conditions, create myriad opportunities for designers to draw from an extensive palette and create unique solutions for the wide range of landscape conditions that we encounter throughout the country.

## GENERAL

Cedarscreen Bevel Back Weatherboards is an external horizontally fixed wall cladding system. This system is used for residential and light commercial building types.

The Cedarscreen Bevel Back system comprises of direct fixed and cavity fixed options (factory finished to all sides with a migrating wood oil).

Cedarscreen installation guides are intended to link the end user to best practise and correct installation of the specified system. In the literature we primarily reference Western Red Cedar as the timber cladding material.

Rosenfeld Kidson also offer Larch and Truwood as alternative timber cladding species. These timbers are independently appraised to comply with B2.3.1 (b).

Where there are key differences in these alternative cladding types, we reference Larch and Truwood separately. This generally relates to the species type scope of use, profiles, finishes, fixing and related details.

These species shall be used in accordance with Rosenfeld Kidson's recommended profiles, fixing, finishing and detailing; in addition to the requirements set out in E2/AS1, B2 and F2.

## SCOPE

- Scope of use conforms to Acceptable Solution E2/AS1 Paragraph 1.1.
- Has a risk score of 0-20 in line with tables 1, 2 and 3 of Acceptable Solution E2/AS1.
- Timber framing to comply with NZS 3604-2011 Timber framed buildings.
- NZS 3604 Wind Zones.
- Aluminium windows and doors joinery to comply with NZS 4211-2008 – Specification for performance windows.
- Materials, products and processes contained within the building scope of NZS 3604-2011.

### New Zealand Building Code (NZBC) performance requirements:

- Clause B1 Structural Performance B1.3.1, B1.3.2, B1.3.3 (a), (h), (j) and (q) and B1.3.4.
- Clause B2 Durability: B2.3.1 (b) 15yrs and B2.3.2.
- Clause E2 External Moisture E2.3.2.
- Clause F2 Hazardous Building Material F2.3.1.

## SPECIES

### WESTERN RED CEDAR

Western Red Cedar (*Thuja plicata*) weatherboards are compliant for above ground use in accordance with New Zealand Standard NZS 3602: 2003 Timber and Wood-based Products for use in Building and when fixed above ground exceeds the minimum 15 year durability requirement.

### LARCH

**Siberian Larch** (*Larix sibirica*)

Larch is utilised in horizontal and vertical cladding profiles that are compliant with Branz Bulletin 411. Siberian Larch timber grade supplied by Rosenfeld Kidson & Co Ltd is a mixture of Grades I, II, and III, called Unsorted I-III. The Unsorted I-III grade of Larch is compliant with NZS3631:1988 NZ Timber Grading Rules. Larch is independently appraised to show compliance with B2.3.1 (b).

The Larch supplied by Rosenfeld Kidson & Co Ltd has a factory applied oiled finish using Dryden WoodOil. The Larch profile types supplied are available in a band sawn face (BSF).

### TRUWOOD®

**Thermally modified Ayous**

Truwood is utilised in horizontal and vertical cladding profiles that are compliant with Branz Bulletin 411. Truwood is a thermally modified, clear grade, low density hardwood. Truwood is produced using the latest thermal modification technology, which involves applying heat at 160 – 230°C, water vapour and pressure to the timber.

The thermal treatment provides a rich Teak coloured timber with great properties of durability and stability. Truwood is independently appraised to show compliance with B2.3.1 (b).

The Truwood supplied by Rosenfeld Kidson & Co Ltd has a factory applied finish using Dryden WoodOil.

### MAINTENANCE

Maintenance shall be carried out as necessary to achieve the required durability of materials, components and junctions. The extent of maintenance is dependent on:

- Type of cladding and components used.
- Position of cladding and components on the building.
- Geographical location, (recoating with stain or Dryden WoodOil will be required more frequently on more exposed northern and western faces).
- Coating manufacturer cleaning and recoating schedules.

Regular maintenance is essential to ensure the performance requirements of the NZBC are met and to maximise serviceability of the system.

Annual inspection of the cladding material must be made to ensure that all aspects of the cladding system, including flashings and joints remain weatherproof. Any damaged areas or areas showing signs of deterioration, which could allow water ingress must be repaired immediately.

Regular cleaning (at least annually) of the Dryden WoodOil coating is required to remove dirt or grime or surface mould. Dirt and grime may be removed with the use of a soft brush, warm water and a light detergent cleaner.

Recoating with Dryden WoodOil will be required throughout the life of the cladding system. Check manufacturer's product specific recoating requirements, as these may vary from product to product.

Rosenfeld Kidson recommends the use of Dryden WoodOil depending on the timber species used with all our exterior weatherboard systems. Recoating must be carried out approximately every 2-3 years in accordance with the manufacturer's instruction.

*Note: some stains or film forming cedar coatings may require annual maintenance. Refer to individual supplier's maintenance guides for appropriate product specifications. Ensure ends of weatherboards and cut or exposed edges are recoated during any general maintenance.*

### SUSTAINABILITY

Western Red Cedar is also favoured by conservationists as the forests of British Columbia, from where our cedar is sourced, are well-managed and certified as such. All our producers carry certification under SFI, CSA, FSC or PEFC. Please refer to the following site for more information regarding this: [www.wrcea.org/environment-sustainability/intro.htm](http://www.wrcea.org/environment-sustainability/intro.htm).

Rosenfeld Kidson Larch and Truwood are sourced with FSC® certification providing independent assurance they are sourced from well-managed forests.

### SIZES & GRADES

Our weatherboards are available in 19mm thicknesses and cover widths range from 58mm up to 203mm.

The standard weatherboard length range is 1.83m to 4.88m, averaging 3.0m. Selected and longer lengths are available on request.

- It is good practice to pre-order weatherboards in the required selected length spread. On-site measuring should confirm the length spread required.



## MANUFACTURING

### PROFILE RANGE

RK61, RK62, RK63 and RK64.

### TRUWOOD

RK61 and RK62.

### LARCH

RK61 and RK62.

Profiles are manufactured to meet the requirements of E2/AS1 (Acceptable Solution). This is achieved with compliance to Clauses 9.4.1 and 9.4.1.1 of E2/AS1 and Clause 9.4.1.3 E2/AS1. Horizontal bevel back profiles are as given in NZS 3617 or Branz Bulletin 411.

### ACCESSORIES

#### Fascia

##### Western Red Cedar fascia

RK69 135x18.5mm, supplied in lengths 3.9m and longer.

RK70 180x18.5mm, supplied in lengths 3.9m and longer.

RK71 135x28mm, supplied in lengths 3.9m and longer.

RK72 180x28mm, supplied in lengths 3.9m and longer.

RK73 230x28mm, supplied in lengths 3.9m and longer.

### INTERNAL AND EXTERNAL CORNERS

#### External

Western Red Cedar, Truwood and Larch cover boards RK91 and RK92, 18.5mm thick boards in widths of 69mm and 90mm, supplied in lengths 2.4m and longer.

*Note: Box corners to be used in conjunction with RK12 scribes.*

External Powder-coated Aluminium Corner RKFL-34 (including RKA908 timber bead).

#### Aluminium Flashing Finishes

Dulux Duralloy 'Matt Black' is the standard finish on RK extrusions. This coating is suitable for all non-exposed flashings and also in non-coastal environments.

For exposed flashings in coastal zones, Dulux Duratec is recommended.

All RK flashings that are exposed/visible are also carried in mill finish to allow coating in Duratec, as well as alternative colours to Matt Black or alternative finishes, such as anodised coatings to match window joinery.

When fixing aluminium, only use stainless steel. Silicon bronze (copper) is non-compatible and should not be used.

#### Internal

Western Red Cedar, Truwood and Larch Internal corner mould RK110 39x39mm supplied in lengths 2.4 and longer.

### MOULDINGS

Western Red Cedar, Truwood and Larch eaves mould RK32 40x27mm or RK33 26x15mm, supplied in lengths 2.4m and longer.

Western Red Cedar, Truwood and Larch bevelled cornice RK7 30x18x10mm, supplied in lengths 2.4m and longer.

### SCRIBER

Western Red Cedar, Truwood and Larch scribes RK12 40x17mm and RK13 40x10mm supplied in selected lengths.

An additional option is to utilise the RKFL-15 concealed scribe. This detail allows the bevel back boards to be trimmed into the flashing and utilising a 32x9mm timber packer.

Refer to diagram B.

### CORROSIVE RESISTANT SOAKERS

RK61 150x22mm corner soaker and flat soaker, 316 stainless steel or copper.

RK62 200x22mm corner soaker and flat soaker, 316 stainless steel or copper.

### FINISH

- BSF Band Sawn Face.
- DF Dressed Face or DFS Dressed Faced Sanded (it is recommended dressed face weatherboards are sanded prior to applying coating products).

### MOISTURE CONTENT

Cladding timbers are delivered to site air-dried to between 16% and 18% moisture content.

### FACTORYCOAT

This is a specifically designed coating process for applying stain and wood oil to our weatherboards. Dryden WoodOil is applied prior to delivery to all faces of the weatherboard profile. These uniquely formulated products will increase the durability and performance of the cladding during its in-service life. Factory coating to all faces not only enhances the visual effect of Cedar, Truwood and Larch but when maintained to manufacturer specifications, it also greatly reduces moisture penetration, limiting excessive hygroscopic movement.

### AT TIME OF ORDER

- Check dressed faced weatherboards are face sanded, if being factory coated.
- Sign off profile confirmation check sheet.
- Sign off colour confirmation check sheet.
- Check pre-order of a minimum 4ltr of Dryden WoodOil for sealing cut or exposed edges.

### HANDLING & STORAGE

Care should be taken to protect Western Red Cedar, Larch and Truwood from the elements. All plastic wrapping, timber gluts, packers and strapping should remain intact until stored in a suitable location.

Packets of bevel back weatherboards should be stored a minimum 100mm clear from the ground at all times. Storage should be in a dry enclosed location where temperature and humidity are kept relatively stable i.e. dry, dust free and free from sub trade contamination.

## FRAMING

### FRAMING

- All framing must comply with NZS 3604.

### WALL UNDERLAYS

- Must comply with Table 23 and Clauses 9.1.5 – 9.1.7 E2/AS1.
- Flexible flashing tape as per Clause 4.3.1.1 E2/AS1.

### FLEXIBLE WALL UNDERLAYS

- Flexible wall underlays shall be in accordance with Table 23 E2/AS1.
- Flexible wall underlays shall be fixed in accordance with Clause 9.1.7.1 E2/AS1.
- Be run horizontally.
- Have upper sheets lapped over lower sheets to ensure that direction of lap will allow water to be shed outside of the wall underlay.
- Be lapped not less than 75mm at horizontal joints.
- Be lapped not less than 150mm over studs and vertical joints – see manufacturer specifications for taped joint options.
- Flexible wall underlay as per Clause 9.1.5 shall be cut and dressed into all sides of openings as per figure 72A and 72B E2/AS1.
- Flexible flashing tape shall be applied to head and sill framing as shown in figure 72A and 72B E2/AS1. Flexible tape shall comply with parts 3.2 and 4 of ICOB Acceptable Criteria AC 148 and be compliant with the wall underlay.
- Extend 35mm below bottom plate or bearer.
- Be restrained from bulging - use polypropylene tape at 300mm centres tape shall be fixed horizontally and drawn taut refer Clause 9.1.8.5 E2/AS1.

### RIGID WALL UNDERLAYS

- Are required in Extra High wind zones refer Table 3 and Table 23 E2/AS1.
- Where walls are not lined such as gable ends, and attic spaces an air barrier compliant to Table 23 E2/AS1 shall be fixed to framing prior to installation of cavity battens. For attached garages, underlays to Clause 9.1.3.4 E2/AS1.
- Rigid wall underlays shall be fixed in accordance with Clause 9.1.7.2 E2/AS1.
- Be a minimum 6mm fibre cement sheet or 7mm H3.2 plywood.
- Be installed with sheet edges fixed over solid framing.
- Be over-fixed with a flexible wall underlay from Table 23 and installed as in Clause 9.1.7.1 E2/AS1.  
*Note: some proprietary systems may not require the addition of a flexible underlay.*
- Flexible wall underlay as per Clause 9.1.5 shall be cut and dressed into all sides of openings as per figure 72A and 72B E2/AS1.

- Flexible flashing tape shall be applied to head and sill framing as shown in figure 72A and 72B E2/AS1. Flexible tape shall comply with parts 3.2 and 4 of ICOB Acceptable Criteria AC 148 and be compliant with the wall underlay.
- Be finished flush with the underside of bottom plate or bearer.

Air seals as per Clause 9.1.6 E2/AS1.

- Windows, doors and other penetration openings shall be provided with flexible air seals to minimise the risk of airflow carrying water into the building wall.

### GROUND CLEARANCE

As per Clause 9.1.3 and Table 18 E2/AS1.

At ground level the base of the cladding material shall overlap the concrete slab a minimum 50mm (*Note: direct fixed only wall cladding shall be off set horizontally 6mm to avoid capillary action.*) The bottom edge of the cladding material shall finish 100mm above a paved surface or 175mm above an unpaved surface.

### PENETRATIONS

As per Clauses 9.1.9, 9.1.9.1, 9.1.9.2, 9.1.9.3 and figure 68 E2/AS1.

### DRAINED CAVITIES

As per Clauses 9.1.8 to 9.1.9.2 E2/AS1.

Cavity battens or spacers shall be compliant with B2 (durability) and be nominal 20mm in thickness and be a minimum 45mm wide.

Cavity battens shall be fixed by the wall cladding fixings, to the wall frame. Claddings are fixed through the cavity battens into the wall framing.

### REQUIREMENTS

- Treatment to meet the requirements of NZS 3640.
- Be installed over wall underlay, either flexible or rigid compliant with Table 23 E2/AS1.
- Be compliant with B2/AS1.
- Be drained and open to the exterior at the bottom of the cavity.
- Vertical cavity battens shall also be fixed at internal and external corner junctions with a minimum 10mm gap between vertical cavity battens.
- Cavity spacers as shown in figure 67 E2/AS1 horizontal spacers shall be finished 50mm minimum from vertical battens positioned with a 5 degree minimum slope.

Vermin proofing as per Clause 9.1.8.3 E2/AS1

- Cavity closer to be used in drained cavities at the base of the wall lining and above window heads and inter storey flashings.
- Cavity closure shall provide ventilation area of 1000mm<sup>2</sup> per metre length. Provide holes or slots between 3mm and 5mm.
- Be positioned to allow a drip edge to the wall cladding of 10mm at the base of walls and 15mm above window and door head flashings.

## FLASHINGS

As per Clause 4.0 E2/AS1.

- Flashing material selection shall comply with Table 20 E2/AS1 and meet the compatibility of Tables 21 and 22 E2/AS1. Flashings shall have a minimum 50mm cover as per Clause 4.5.2 E2/AS1.
- Ensure material thicknesses are as per the requirements of Clause 4.0 E2/AS1 prior to ordering.
- Internal and external corners refer figure 79 and Clause 9.4.4.5 E2/AS1.
- Aluminium flashings to be powder coated to all faces and edges.
- Flashing dimensions as per Table 7 E2/AS1.

## FIXINGS

As per Table 24 E2/AS1.

Diagram A

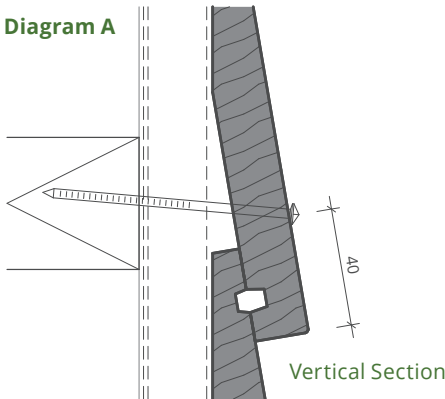

### Direct Fixing

- Rosenfeld Kidson pentagon head annular grooved nails 75x3.2mm, stainless steel 316 or silicon bronze.

### Cavity Fixing

- Rosenfeld Kidson pentagon head annular grooved nails 75x3.2mm, stainless steel 316 or silicon bronze, or 85x3.2mm when using a rigid underlay..

### Windows & Doors

The weatherboard system relies on the joinery meeting the requirements of NZS 4211 for the relevant Building Wind Zone or wind pressure.

- Shall be in accordance with Clauses 9.4.6 to 9.4.7 and figures 81 and 85 E2/AS1.
- Window profiles to be selected to achieve cover shown in details.
- Wall underlays to wall openings as per Clause 9.1.5 E2/AS1.
- Sill support bar required conforming to EM6 and Clause 9.1.10.5 refer figure 72B E2/AS1.
- For Very High and Extra High wind zones seal head flashing to window flange as per figure 71b E2/AS1.

## HEAD FLASHING

- Head flashings shall be fixed with a minimum 35mm cover flashing upstand with additional flexible underlay or tape overlapped over the flashing upstand.

- Extra High wind zones require a minimum 75mm cover flashing to head flashing upstand.
- Ensure head flashings have a minimum 15 degree fall with a 5mm gap between head flashing and weatherboard refer figure 83 E2/AS1.
- Head flashings shall be fixed with stop-ends to suit the cavity depth, head flashing shall extend to provide 30mm cover or if scribes are used the flashing shall extend 20mm past the finished scribe – refer figure 81 and 85 (a) and (c) E2/AS1.
- Window sill joinery cover shall be a minimum 8mm at the sill and 10mm minimum at jambs. Jambs shall be scribed using RK12 profile as per figure 81 and 85 (c) E2/AS1.

Air seals as per 9.1.6 E2/AS1.

- Ensure an air seal is provided with a flexible air seal to minimise the risk of airflows carrying water into the building wall. The air seal shall be installed between the reveal or frame and the wrapped opening as per figure 81 E2/AS1. Be installed over a closed cell polyethylene foam (PEF) backing rod.
- And (i) self-expanding polyurethane foam or (ii) sealant complying with clause 9.1.6 (a) and (b) E2/AS1.
- Temporary packers shall be removed after fixing.

---

## FIXING BEVEL BACK WEATHERBOARDS

### LIMITATIONS

Cedarscreen Bevel Back must only be installed by a registered LBP (Licenced Building Practitioner).

Fixing methods shall be in accordance with Clause 9.4 E2/AS1.

- Check weatherboards are factory oiled on all surfaces prior to delivery.
- Apply Dryden WoodOil to all cut or exposed edges prior to installation.
- Ensure on-site provisions are appropriate, allowing for good storage and working space.
- Ensure all timber products are free from sub-trade and climatic contamination during the building process.

### FIXING PROCESS

- Check weatherboard length spread and use appropriately to suit each cladding face.
- Start the fixing process from the bottom plate. Set out a storey rod and account for key measurements between the bottom plate, window head and top plate. This will help set out an accurate layout and position the weatherboards accurately at wall junctions and openings.
- Position weatherboards ensuring a minimum 50mm overhang of the bottom plate.

## FIXINGS

Weatherboards shall be fixed through the wall underlay to the framing in accordance with Table 24 E2/AS1.

- Fixings shall be hand driven.
- Weatherboards shall be pre-drilled prior to fixing with a single fixing to each fixing point. Do not brad nail weatherboards prior to face nailing.
- Laps shall be 32mm for standard bevel back and 25mm for rebated bevel back boards with a minimum 2mm gap at the overlap between rebated boards.
- Ensure the 8x4mm and 8x6mm weathergrooves are lined up to form an 8x10mm weathergroove or 6x4mm for rebated bevel back line up to form a 6x8mm weathergroove.
- Locate nails 10mm above the lap.
- A minimum of 35mm fixing penetration into the framing is required. For fixing over a cavity use 85x3.2mm annular grooved nails. For direct fixing use 60x3.2mm annular grooved stainless steel 316 or silicon bronze nails.
- Bevel back weatherboards shall be fixed to framing at a maximum 600mm centres.
- Bevel back weatherboard joints shall be made over supports be scarf or splay cut. Position cut edges against the prevailing wind and cover with corrosive resistant flat soakers.

## WINDOWS AND DOORS

- Ensure head flashing stop-ends are in place prior to nailing weatherboards.
- Jamb shall be scribed with the RK12 profile as per figure 81 and 85 (c) E2/AS1.
- Scribes are to be sealed to weatherboards.

Diagram B

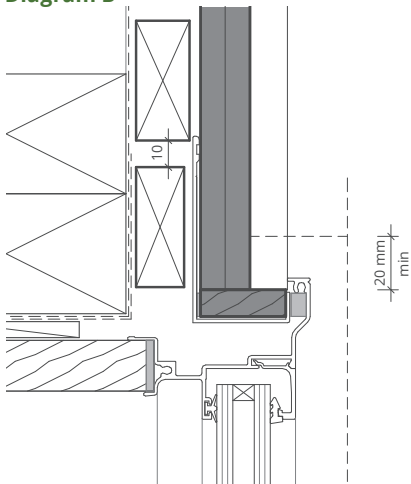

## CORNERS

- Internal corners shall be weatherproofed with RKFL09 65x65mm powder-coated back flashings. Weatherboards are scribed and notched, or use internal corner cover boards RK91 and RK92, that are 18.5mm thick in widths of 69mm and 90mm, used in conjunction with RK12 scribes. Alternatively use internal corner mould RK110 39x39mm, supplied in lengths 2.4m and longer.
- External corners shall be weatherproofed with RKFL09 65x65mm powder-coated back flashings. Weatherboards are mitred and covered with corrosive resistant corner soakers or external corner cover boards RK91 and RK92, 18.5mm thick in widths of 69mm and 90mm, used in conjunction with RK12 scribes. An additional external corner option is to use the RKFL-34 corner flashing along with the RKA908 external corner mould, refer to Diagram D.

Diagram C

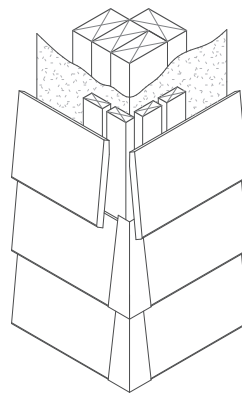
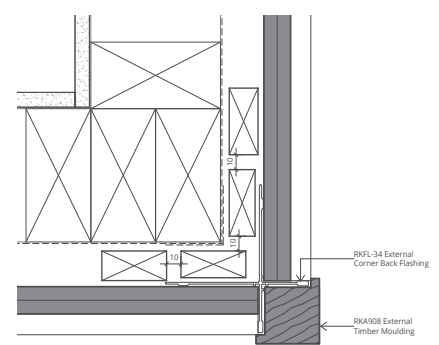

Diagram D



## FINISHING

- Apply the finishing coat of Dryden WoodOil.  
Use Dryden WoodOil as per manufacturer specifications.

Recommended coverage rates for onsite application of Dryden WoodOil. (These are indicative rates and coverage may vary depending on site conditions).

**Dryden WoodOil** is a deep, migrating oil that not only adds colour but enhances the timber's natural properties, protecting surface fibres and stabilising the timber's cell structure. To ensure an optimum performance level is achieved your cladding should be annually cleaned and maintained in accordance with Dryden manufacturer maintenance schedules.

- Recommended coverage rate for BSF 8-10 m2 per ltr.
- Recommended coverage rate for DF 10-12 m2 per ltr.



WORKINGSPEC

# BEVEL BACK QR CODE SHEET

## RKFL-34 EXT. CORNER ON 20MM

<http://wksp.nz/rk-b20-fu23>

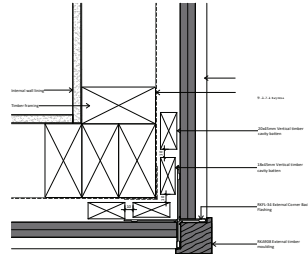

## BEVELBACK STANDARD WINDOW TRIMMING

<http://wksp.nz/rk-b20-fu01-03>

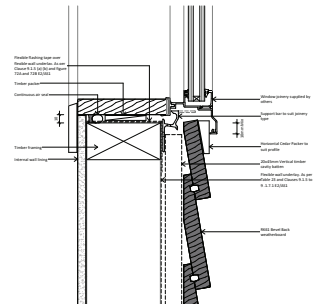
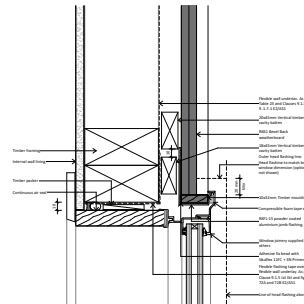
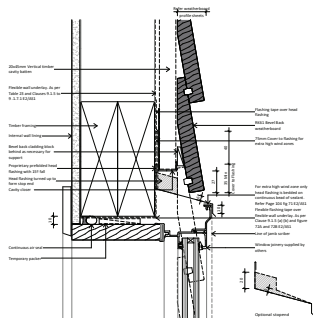

interactive assembly instructions available

To view interactive, 3D assembly instructions install the **WorkingSpec** app and scan the appropriate QR code, or visit the website listed.

Get **WorkingSpec** from the App Store or Google Play.



**E:** [rk@rosenfeldkidson.co.nz](mailto:rk@rosenfeldkidson.co.nz)  
**W:** [www.rosenfeldkidson.co.nz](http://www.rosenfeldkidson.co.nz)  
[www.cedarscreen.co.nz](http://www.cedarscreen.co.nz)

Postal Address: P O Box 621,  
Shortland Street, Auckland 1140

**Auckland:**  
**T:** +64 9 573 0503  
**F:** +64 9 573 0504  
513 Mount Wellington Highway,  
Mount Wellington,  
Auckland 1060

**Christchurch:**  
**T:** +64 3 349 3316  
**F:** +64 3 349 3317  
15 Edmonton Road, Hornby,  
Christchurch 8042