

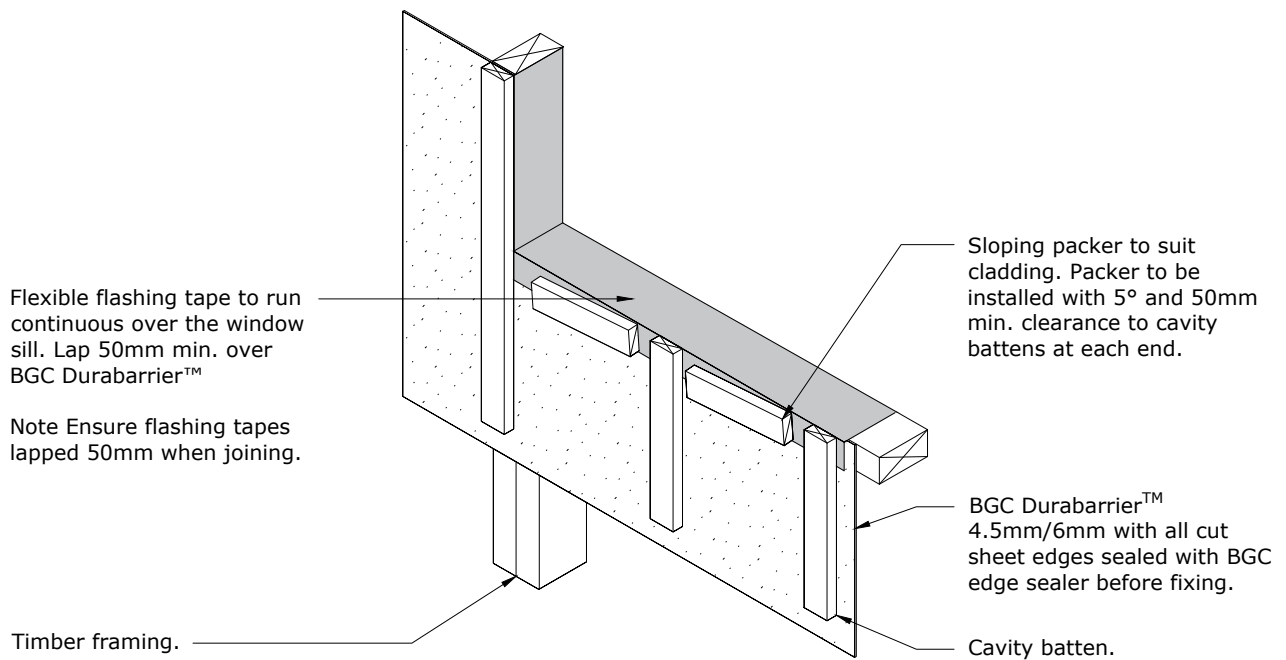

Fibre Cement

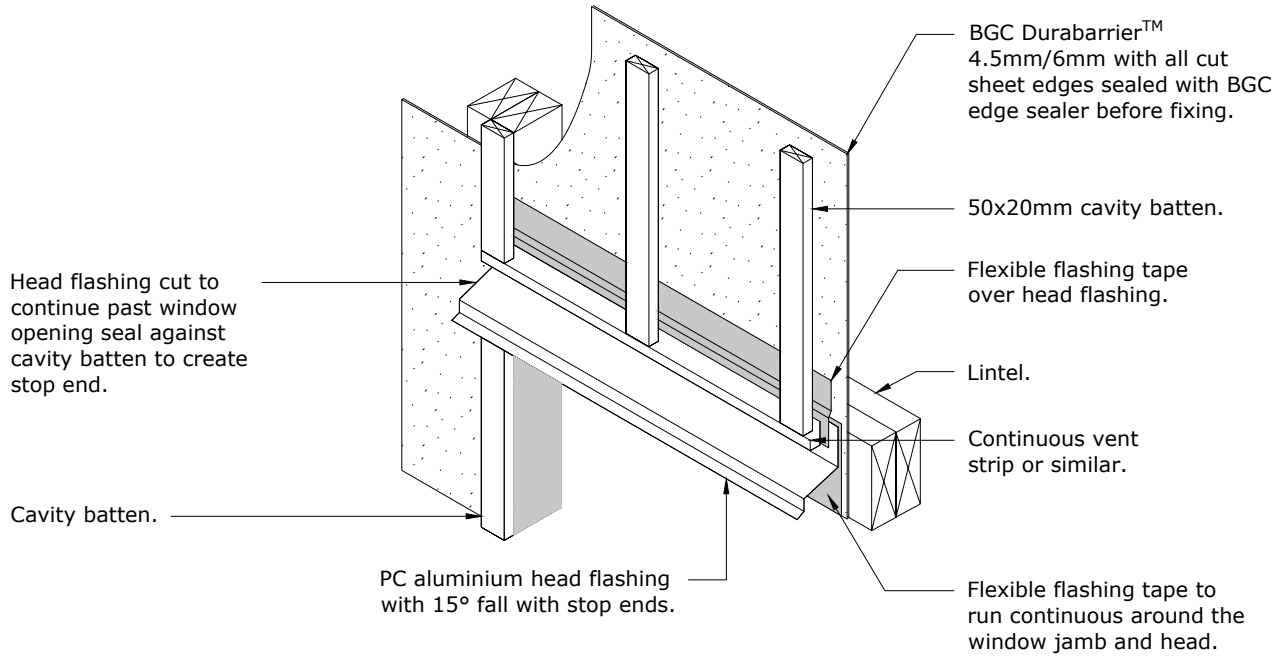

PROFILE BGC DurabARRIER™ 4.5mm / 6mm

DATE Aug 2018
SCALE NTS @ A4

DETAIL 3D Window Section

DETAIL NO. DB22