

INTRODUCING THE MOSS

FLUSH MOUNT 360° PIR CEILING SENSOR

IP44 when installed
allows for same fitting
inside as well as on
covered porches and
soffits

Designed to sit 27mm above
GIB when installed, allowing
installation under ceiling
battens

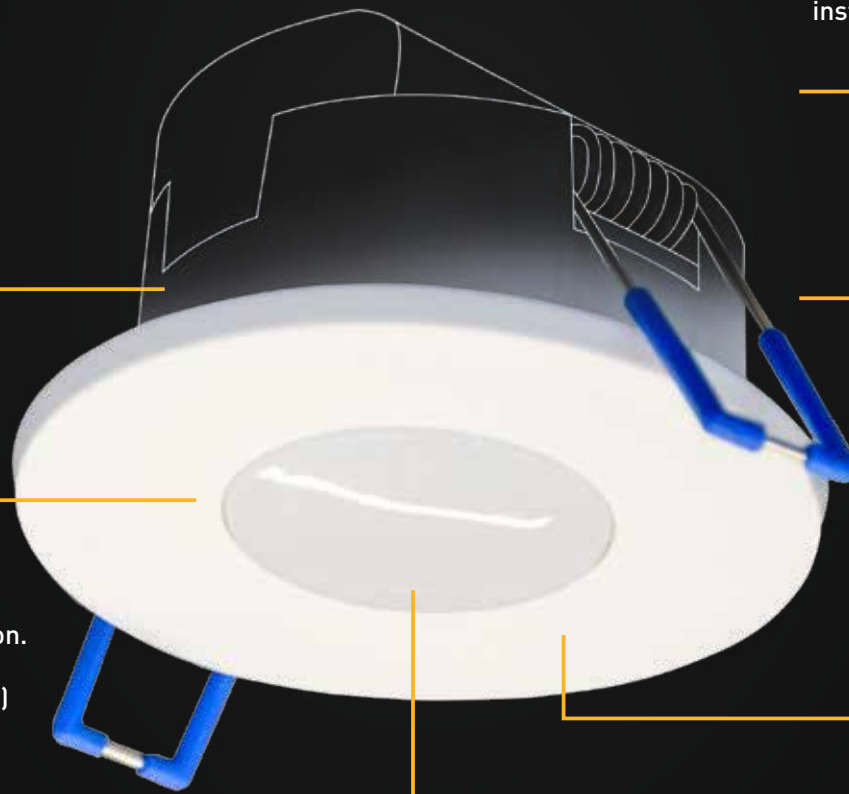

UV stabilised to protect
against plastic degradation.
The Main Body is made
from Polycarbonate (PC)
and the Lens from High
Density Polyethylene
(HDPE).

Flush look lens for
seamless look
when installed

Advanced engineering
means excellent detection
range without the need for
a protruding dome lens

VYNCO

R&D™

New Zealand engineered, researched
& designed by Vynco's in-house team

find us:   #VYNNNOVATION

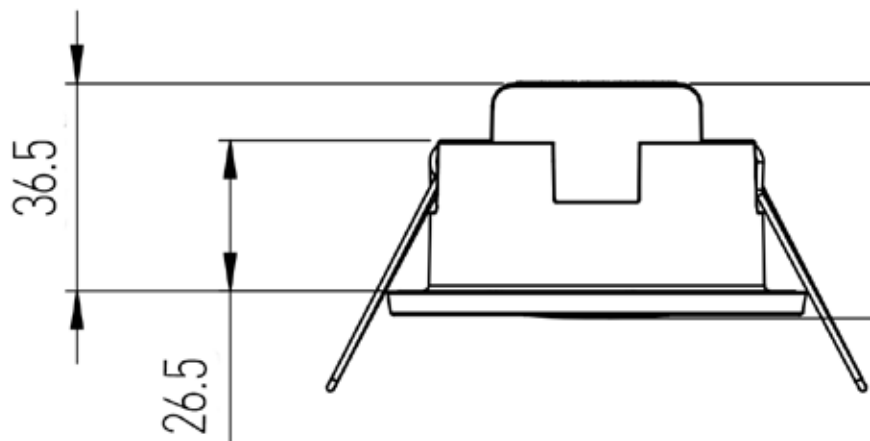
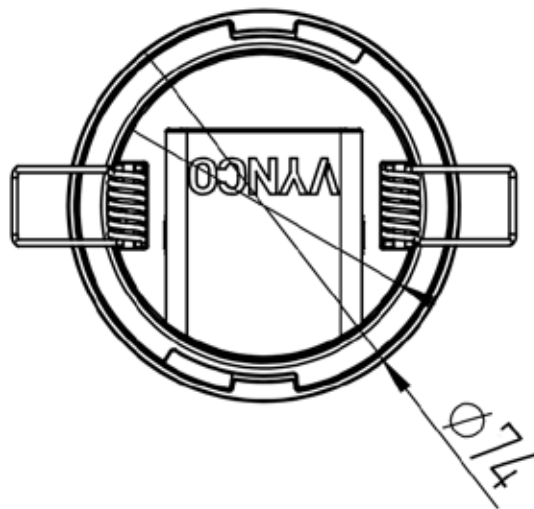

Look out for the unique
Eco-friendly pulp moulded fibre packaging
with NO paper waste!



Code	Switch Load Ratings	Detection Range	Cutout	Time Adjustment	Lux Adjustment	Warranty	Trade Price
VMOSS	2000W Incandescent 450W Fluorescent 400W Motor / Fan 400W LED	6m Ø at 2.4m Height	60mm Ø	5 seconds to 30min	10 to 2000Lux	3 years	\$55.00

VYNCO

Christchurch Office

388-396 Tuam Street, Phillipstown, Christchurch 8011
PO Box 9022, Tower Junction, Christchurch 8149
P (+64) 3 379 9283 F (+64) 3 379 6838
E sales@vynco.co.nz

Auckland Office

9 Levene Place, Mt Wellington, Auckland 1061
PO Box 12 249, Penrose, Auckland 1642
P (+64) 9 525 6051 F (+64) 9 525 5799
E sales@vynco.co.nz