



PRESS-FIT PRODUCT & TECHNICAL MANUAL

Design & Installation Guide, 2019

www.mayerstainless.co.nz



AS 3688
AS 5200.053



022882



BRANZ Appraised
Appraisal No.1033 [2018]

MAYER STAINLESS PRESS-FIT PIPE SYSTEMS ARE
DESIGNED AND PRECISION-MANUFACTURED
FROM TOP-GRADE TAIWANESE STAINLESS STEEL.
RIGOROUS QUALITY CONTROL AND COMPLIANCE
WITH APPLICABLE INDUSTRY STANDARDS
DELIVERS THE LASTING BENEFITS OF STAINLESS
STEEL COMBINED WITH EASY INSTALLATION.



CONTENTS



1

PRODUCT INFORMATION

- Features
- Press Fitting
- Fields of Application

2

QUALITY ASSURANCE

- 4 Mayer Complies with
- 5 Industry Standards
- 6 Tube Specification
- Manufacturing
- Potable Water Standards
- Compliance
- Pressure & Temperature
- Certification
- Gas Applications

3

PRODUCT RANGE

- Press Fittings 12
- O-rings 19
- Munsen Rings 20
- Tools 21

4

PRESS JOINTING

- Guidelines, Tool Use & Preparation

5

INSTALLATION

- Linear Expansion 27
- 24 Fastening 28
- Fixed Point 28
- Risers 28
- Sliding Points 28
- Support Intervals 28
- Distance Between Fittings 28
- Expansion & Bending Legs 29
- Expansion Loop 29
- Storage & Handling 30
- Corrosion & 316L Pipe & Fittings 30
- Earthing 30
- Connection of Pipes with Different Materials 30
- Thermal/Acoustic Insulation Materials 30
- Fire Protection 31
- Heat Trace 31
- Antifreeze 31
- Pressure Testing & Flushing 31
- Mayer Test Record 32
- Installing Stainless Pipes Through Footings or Floors 33
- Chemical Compatibility & O-rings 34
- Pressure Loss 36

6

TRAINING & WARRANTY

- Training 43
- 3 Stages of Training 43
- Tool Hire & Servicing 43
- Warranty & Lifetime Statement 44
- Liability Warranty 44
- Notes 45

SECTION 1

PRODUCT INFORMATION

Mayer Stainless Steel pipe systems are the first choice in metallics for flexibility, durability, ease of installation and longevity. Suitable for commercial and industrial applications, Mayer pipe systems deliver a competitive return on investment, with a favourable total cost of ownership. An extensive range of pipes and fittings from 15mm to 108mm provides installers with a complete solution to meet diverse needs. Quality is assured: all pipes and fittings must pass rigorous air and water tightness tests before leaving the factory.



FEATURES



Mayer stainless steel pipes and fittings start with the selection of the finest raw materials. Each pipe and fitting is manufactured in an ultra-modern facility where attention to detail guarantees the quality of every item which leaves the factory. Extensive individual testing of each pipe or fitting, including rigorous hydraulic pressure testing, eddy current testing, and annealing of all pipe and fittings to ensure optimal quality standards are consistently met.

Mayer has earned an enviable reputation and is the product of choice for installers due to its high quality, durability and cost-competitiveness.

Fast & Easy to Use

Installing Mayer stainless steel pipe systems delivers advantages over traditional brazed copper or bonded PVC systems. Mayer is press fitted with rubber O-rings. That means water doesn't have to be fully drained prior to making joints, unlike welded systems. Time isn't spent waiting for adhesive bonds to set. And there is no heat or flame, which means no hot-works permit. As a result, installing Mayer is faster, easier, cleaner and safer.

High Quality 316L Stainless Steel Tube

Each Mayer pipe and fitting is precision-manufactured from certified 316L stainless steel. Pipe features include:

- Low carbon (<0.03%) with between 2-3% Molybdenum content ensures even higher corrosion resistance
- Sizes 15–108mm
- AS 5200.053 compliant

Stainless steel press fittings features include:

- 316L material EN 1.4404 (press fittings)
- 316Ti material EN 1.4571 (threaded parts)
- 316 material EN 1.4408 (precision cast parts)

Push & Stay & Leak Path

Fitting Mayer stainless steel pipe systems is rapid and simple. Start with hand-fitted joints, which are sufficiently tight to complete the rough-in. With this approach, adjustments can be made to get the right pipe design and placement. Finally, complete each joint by pressing. All joints which are not yet pressed will leak (Leak Path), allowing for easy identification of those which are completed and those which are not.

Press with Ease with Mayer Tooling

Gearing up to supply and install Mayer stainless steel pipe systems is easy. If you have previously pressed copper, in many cases an upgrade of jaws will be all that will be required, check your tool's compatibility with your local distributor.

Mayer tools feature:

- Ergonomic, lightweight design
- Tools well balanced with one hand operation in most sizes
- Includes powerful Li-ion batteries

PRESS FITTING

Press Profile & Process

Mayer stainless fittings do not deform when fitted. This ensures turbulence isn't introduced to the finished piping system, so the medium flowing through the pipe is unimpeded. The fitting as well as the pipe is stainless steel, delivering a rigid, watertight coupling. The press fitting process delivers a permanent connection. Mayer Stainless Steel provide an 'M' press for sizes up to 54mm, and larger dimensions utilising a 'V' profile.



Mayer 316L stainless pipe and fittings offer a wide range of fields of application due to the material's robustness and corrosion resistance.

In consideration of installations it is important to check the suitability of the 316L material in the application and as well the type of press O-ring required.



**Black Chloramine resist
EPDM O ring**

Mayer press fittings are standard with a black EPDM (Ethylene Propylene Diene Monomer). These standard O-rings are ideal for potable water hot and cold in a temperature range of -20°C - 99°C with a working pressure of 16 Bar. Higher pressures can be considered subject to application and discussion with Mayer NZ.

Mayer have introduced to their press fittings the new Chloramine resistant EPDM O-ring which offers significant improvement to longer seal life where systems are exposed to high chlorine levels/dioxides and flushing.



Red FKM industrial

Ideal for industrial applications, compressed air, elevated temperatures and chemicals (see relevant chart chemical compatibility and O-ring selection pages 32/33). Mayer recommends a temperature range of -20°C - 99°C with a working pressure of 16 Bar. Mayer do not recommend the system is used for steam application. For installation and application support contact Mayer NZ.



Yellow HNBR gas applications

Ideal for gas applications and liquids gas/chemical inside or outside buildings (see relevant chart chemical and gas compatibility, O-ring selection pages 32/33). Mayer recommends a temperature range of -20°C - 99°C with a maximum working pressure of 16 Bar. For all applications and or chemical consideration it is recommended to contact Mayer NZ.

FIELDS OF APPLICATION

Below is a quick reference guide for the suitability of Mayer stainless application and the recommended O-ring change out. Consideration must also be given to match suitability of any other seals as well in your system (flanges etc).

EPDM Black

- Potable water cold and hot
- Chilled water
- Heating water
- Cooling/process water
- Condenser water
- Rain water harvesting
- Swimming pools
- RO systems

FKM Red

- Solar
- Heating water
- Condenser water
- Compressed air
- Industrial applications
- Chemical dosing
- Non-potable applications

HNBR Yellow

- Gas systems
- Chemical dosing



SECTION 2

QUALITY ASSURANCE

Quality is at the heart of Mayer stainless steel pipe systems. From raw materials, to sheet stainless steel and finally to the manufacture of individual pipes and fittings, every process and procedure is rigorously aligned with industry standards and best practices. No items leave the Mayer factory until they have passed stringent Quality Assurance tests.

Mayer stainless steel products are certified suitable for potable water, reverse osmosis water, process water, glycol, HVAC applications of chilled and heating water, and more.

Our end-to-end quality standards mean when Mayer stainless steel arrives on site, it can be depended upon. Every time.

MAYER COMPLIES WITH INDUSTRY STANDARDS

Material	Stainless steel grade SS316L EPDM black rubber (potable), FKN red rubber (industrial, temps above 99°C), HNBR yellow rubber for gas installations
Pressure Rating	16Bar
Operating Temperature	-20°C to 99°C
Suitable Tube	GB/T 19228.2, GB/T 12771 Stainless Steel Tube, BS 10312 Stainless Steel Tube
Applications	Potable hot and cold water services, high temp to 99°C and GAS

Mayer Stainless Steel pipes are compliant with AS 5200.053 and supplied as straight 5.8 metre lengths with outside diameters in the range 15mm to 108mm.

All 316L pipes are constructed of Austenitic Stainless EN 1.4404, complying with DIN EN 10088, fabricated according to DIN EN 10312 and DVG-W543 which conforms to standard EN 10088 (AISI 316L) fabricated according to EN 10312 and WRAS. Mayer Stainless fittings are manufactured to the highest of standards.

Marking

All Mayer pipes and press fittings are stamped in accordance with relevant standards to indicate the relevant application.

TUBE SPECIFICATION

Nominal Size	Outside Diameter mm	Wall Thickness	Dry Weight kg/m	Wet Weight kg/m	Volume l/m	Tube Length m
DN15	15	1.0	0.351	0.484	0.133	5.8
DN20	22	1.2	0.625	0.928	0.302	5.8
DN25	28	1.2	0.805	1.321	0.515	5.8
DN32	35	1.5	1.258	2.062	0.804	5.8
DN40	42	1.5	1.521	2.718	1.195	5.8
DN50	54	1.5	1.972	4.015	2.043	5.8
DN65	76.1	2.0	3.711	7.794	4.083	5.8
DN80	88.9	2.0	4.352	10.58	6.232	5.8
DN100	108	2.0	5.308	13.810	8.495	5.8



MANUFACTURING



MAYER STAINLESS STEEL PIPES AND FITTINGS ARE PRODUCED WITH TOP-GRADE RAW MATERIALS FROM BRANDED SUPPLIERS. EACH PIPE OR FITTING MUST ACHIEVE A 100% PASS OF HYDRAULIC PRESSURE AND AIRPROOF TESTS BEFORE LEAVING THE FACTORY TO ENSURE EXCELLENT QUALITY.

Manufactured in a dedicated stainless facility since 1995, all Mayer stainless steel products are produced by Mayer Corp., Ltd in a state-of-the-art facility covering 82.5 acres. The pipe and fittings factory was established by the Mayer Steel Pipe Co., Ltd, itself founded in 1959 for the production of steel and stainless steel.

The factory is recognised as a AAA risk management enterprise with quality management systems in force, automated assembly lines and robotic welding systems.

Quality products start with the best raw materials. Sourced from first grade steel and coil mills, every item is tracked throughout the supply chain to ensure end-to-end quality management.

Every Mayer stainless pipe and fitting is manufactured to 316L grade (EN 1.4404) austenitic stainless which conforms to standard BS EN 10088-1:2005 (AIS 316L).



QUALITY ASSURANCE

Fittings are manufactured from the same material as the pipes.

- Tolerances are in accordance with EN 10312, WRAS 1704328
- Welding seams are 100% eddy-current tested
- Surface finishes are annealed in all dimensions

Mayer applies complete Quality Management Systems to its stainless steel pipe and fittings manufacturing operations:

- Processing stainless GB/T 1 9001-2008/ISO9001; 2008 Standard
- Occupational Health and Safety for processing Stainless GB/T28001-2011 Standard
- Environmental management for processing Stainless GB/T240001-2004 (ISO14001: 2004)

Additionally, an in-house quality system ensures all individual tubes and fittings undergo high pressure and tightness tests to 5MPa and are eddy-tested to ensure 100% leak testing quality.

Because of these stringent quality processes, materials and systems, Mayer stainless pipes and fittings are recognised for their suitability for potable water, engineering and food processing applications. Mayer stainless pipes are installed in some of the most recognised buildings in the Asia Pacific region, with reference sites including Taipei 101 and the Beijing and Shanghai International Airports.

POTABLE WATER STANDARDS COMPLIANCE

Mayer stainless pipes and fittings manufactured from 316L grade (EN 1.4404) austenitic stainless, holds WRAS product approval 1704328, which conforms to standard BS EN 10088-1:2005 (AIS 316L).

Mayer stainless also hold BRANZ appraisal 1033 (2018) as being compliant under NZBC.

Further more AS 3688 and AS 5200.053 under WaterMark licence 022882.



PRESSURE & TEMPERATURE CERTIFICATION

All pipes carry clear Mayer identification marks which include dimensions, material conformity, maximum temperature and pressure ratings, compliance certifications, 316L identification, and batch production date.

Working pressure of 16 bar for hot and cold water is confirmed by Mayer WRAS approval. Higher pressures can be achieved for continuous use, subject to individual project application and requirements.

GAS APPLICATIONS

Mayer 316L pipes are suitable for above ground liquid and natural gas applications. It is essential to use HNBR (Hydrogenated Nitrile Butadiene Rubber) yellow gas O-rings only in this application. Compliance with NZ gas codes must be followed in all respects. Not suitable for in-ground applications.

SECTION 3

PRODUCT RANGE

The Mayer press fit pipe system offers a complete range of products manufactured from inert 316L stainless steel with diameters ranging from 15–108mm. An extensive inventory of joints and connecting O-rings ensures tailoring the system to meet exact requirements for each job site. Every Mayer product, no matter how large or small, is manufactured to exacting standards. When Mayer stainless steel pipes arrive on site, they are quality certified, dependable and ready for installation. The longevity of stainless steel is unmatched; once deployed, Mayer is there for the life of the building.

Installation is rapid, with no heat or solvents, and a Leak Path providing a tell-tale method of identifying which joints are completed.

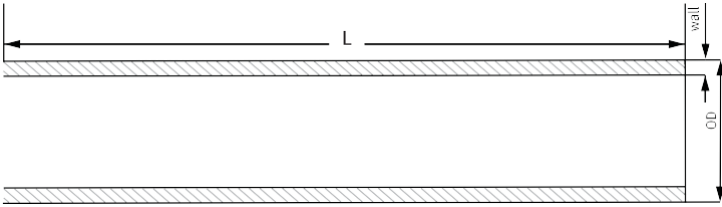
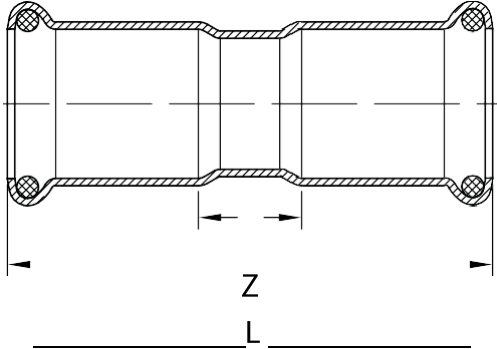
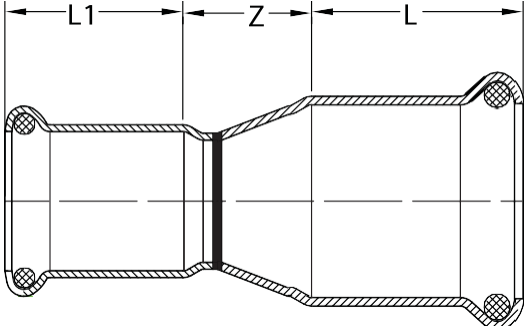
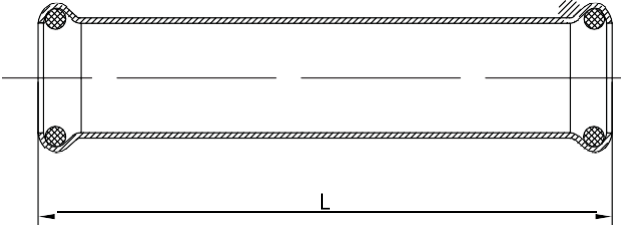

MAYER STAINLESS STEEL PRESS FITTING M & V PROFILES

SS PIPE	Product Code		Size/OD	L	Wall		
	E0100015		15	5.8	1		
	E0100022		22	5.8	1.2		
	E0100028		28	5.8	1.2		
	E0100035		35	5.8	1.5		
	E0100042		42	5.8	1.5		
	E0100054		54	5.8	1.5		
	E0100076		76.1	5.8	2.0		
	E0100089		88.9	5.8	2.0		
	E0100108		108	5.8	2.0		
	COUPLING	EPDM	Gas	FKM	Size	L	Z
	E1000015	G1000015	F1000015	15	48	8	
	E1000022	G1000022	F1000022	22	50	8	
	E1000028	G1000028	F1000028	28	54	8	
	E1000035	G1000035	F1000035	35	62	10	
	E1000042	G1000042	F1000042	42	71	9	
	E1000054	G1000054	F1000054	54	83	13	
	E1000076	G1000076	F1000076	76.1	157	42	
	E1000089	G1000089	F1000089	88.9	170	42	
	E1000108	G1000108	F1000108	108	190	42	
	REDUCING COUPLING	EPDM	Gas	FKM	Size	L	L1
	E1102215	G1102215	F1102215	22x15	21	20	33
	E1102822	G1102822	F1102822	28x22	23	21	36
	E1103522	G1103522	F1103522	35x22	26	21	39
	E1103528	G1103528	F1103528	35x28	26	23	41
	E1104228	G1104228	F1104228	42x28	31	23	41
	E1104235	G1104235	F1104235	42x35	31	26	39
	E1105428	G1105428	F1105428	54x28	35	23	48
	E1105435	G1105435	F1105435	54x35	35	26	41
	E1105442	G1105442	F1105442	54x42	35	31	41
	SLIP COUPLING	EPDM	Gas	FKM	Size	L	
	E1300015	G1300015	F1300015	15	80		
	E1300022	G1300022	F1300022	22	84		
	E1300028	G1300028	F1300028	28	91		
	E1300035	G1300035	F1300035	35	102		
	E1300042	G1300042	F1300042	42	120		
	E1300054	G1300054	F1300054	54	140		

Please reference EPDM, Gas, or FKM product codes when ordering fittings.

REDUCER WITH PLAIN END		EPDM	Gas	FKM	Size/OD	L	L1	Z
	E1202215	G1202215	F1202215	22x15	64±3	25		44
	E1202815	G1202815	F1202815	28x15				
	E1202822	G1202822	F1202822	28x22	64±3	26		43
	E1203515	G1203515	F1203515	35x15	81±4	28		61
	E1203522	G1203522	F1203522	35x22	80±4	28		59
	E1203528	G1203528	F1203528	35x28	74±4	28		51
	E1204222	G1204222	F1204222	42x22	95±4	38		74
	E1204228	G1204228	F1204228	42x28	89±4	38		66
	E1204235	G1204235	F1204235	42x35	88±4	38		62
	E1205422	G1205422	F1205422	54x22	115±4	42		94
	E1205428	G1205428	F1205428	54x28	106±4	42		83
	E1205435	G1205435	F1205435	54x35	105±4	42		79
	E1205442	G1205442	F1205442	54x42	100±4	42		69
	E1207654	G1207654	F1207654	76.1x54	170±4	115		140
	E1208954	G1208954	F1208954	88.9x54	200±4	130		165
	E1208976	G1208976	F1208976	88.9x76.1	212±4	123		155
	E1210854	G1210854	F1210854	108x54	207±4	135		172
	E1210876	G1210876	F1210876	108x76.1	238±4	140		178
	E1210889	G1210889	F1210889	108x88.9	238±4	140		178
FEMALE COUPLING		EPDM	Gas	FKM	Size	L	Z	
	E1415012	G1415012	F1415012	15x1/2	59		38	
	E1415034	G1415034	F1415034	15x3/4	61		40	
	E1422012	G1422012	F1422012	22x1/2	61		39	
	E1422034	G1422034	F1422034	22x3/4	63		41	
	E1428100	G1428100	F1428100	28x1	69		43	
	E1435114	G1435114	F1435114	35x11/4	72		45	
	E1442112	G1442112	F1442112	42x11/2	74		45	
	E1454200	G1454200	F1454200	54x2	88		51	
	MALE COUPLING		EPDM	Gas	FKM	Size	L	Z
	E1615012	G1615012	F1615012	15x1/2	59		39	
	E1615034	G1615034	F1615034	15x3/4	61		41	
	E1622012	G1622012	F1622012	22x1/2	61		40	
	E1622034	G1622034	F1622034	22x3/4	62		41	
	E1628100	G1628100	F1628100	28x1	69		46	
	E1635114	G1635114	F1635114	35x11/4	72		46	
	E1642112	G1642112	F1642112	42x11/2	74		43	
	E1654200	G1654200	F1654200	54x2	88		53	
	E1676250	G1676250	F1676250	76.1x21/2	128		43	
	E1689300	G1689300	F1689300	88.9x3	136		50	
	E1610840	G1610840	F1610840	108x4	162		65	

Please reference EPDM, Gas, or FKM product codes when ordering fittings.

90° BEND	EPDM	Gas	FKM	Size	L	Z
	E2000015	G2000015	F2000015	15	39	19
	E2000022	G2000022	F2000022	22	48	27
	E2000028	G2000028	F2000028	28	57	34
	E2000035	G2000035	F2000035	35	69	43
	E2000042	G2000042	F2000042	42	87	56
	E2000054	G2000054	F2000054	54	107	72
	E2000076	G2000076	F2000076	76.1	165	115
	E2000089	G2000089	F2000089	88.9	180	120
	E2000108	G2000108	F2000108	108	215	140

90° BEND WITH PLAIN END	EPDM	Gas	FKM	Size	L	L1	Z
	E2200015	G2200015	F2200015	15	39	45	19
	E2200022	G2200022	F2200022	22	48	54	27
	E2200028	G2200028	F2200028	28	57	63	34
	E2200035	G2200035	F2200035	35	69	75	43
	E2200042	G2200042	F2200042	42	87	93	56
	E2200054	G2200054	F2200054	54	107	113	72
	E2200076	G2200076	F2200076	76			
	E2200089	G2200089	F2200089	89			
	E2200108	G2200108	F2200108	108			

MALE 90° BEND	EPDM	Gas	FKM	Size	L	L1	Z
	E2315012	G2315012	F2315012	15x1/2	39	52	19
	E2322034	G2322034	F2322034	22x3/4	48	61	27
	E2328100	G2328100	F2328100	28x1	57	69	34
	E2335114	G2335114	F2335114	35x11/4	69	79	43
	E2342112	G2342112	F2342112	42x11/2	87	93	56
	E2354200	G2354200	F2354200	54x2	107	113	72
	E2376212	G2376212	F2376212	76X21/2			
	E2389300	G2389300	F2389300	88.9X3			

FEMALE 90° BEND	EPDM	Gas	FKM	Size	L	L1	Z
	E2415012	G2415012	F2415012	15x1/2	39	52	19
	E2422034	G2422034	F2422034	22x3/4	48	61	27
	E2428100	G2428100	F2428100	28x1	57	69	34
	E2435114	G2435114	F2435114	35x11/4	69	79	43
	E2442112	G2442112	F2442112	42x11/2	87	93	56
	E2454200	G2454200	F2454200	54x2	107	113	72

Please reference EPDM, Gas, or FKM product codes when ordering fittings.

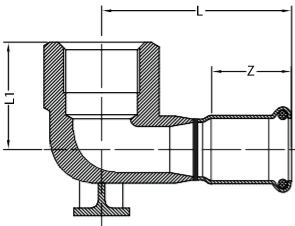
90° ELBOW WITH WALL PLATE	EPDM	Gas	FKM	Size	L	L1	Z
	E2515012	G2515012	F2515012	15x1/2	42	30	20
	E2522034	G2522034	F2522034	22x3/4	57.5	36	23
	E2528100	G2528100	F2528100	28x1	58	42	24

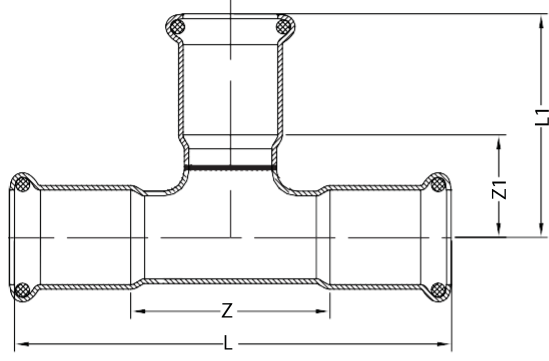
EQUAL TEE	EPDM	Gas	FKM	Size	L	Z	L1	Z1
	E3000015	G3000015	F3000015	15	64	24	40	20
	E3000022	G3000022	F3000022	22	74	32	47	26
	E3000028	G3000028	F3000028	28	84	38	52	29
	E3000035	G3000035	F3000035	35	100	48	58	32
	E3000042	G3000042	F3000042	42	116	54	66	35
	E3000054	G3000054	F3000054	54	138	68	77	42
	E3000076	G3000076	F3000076	76.1	236	122	120	60
	E3000089	G3000089	F3000089	88.9	264	140	127	65
	E3000108	G3000108	F3000108	108	310	165	147	73

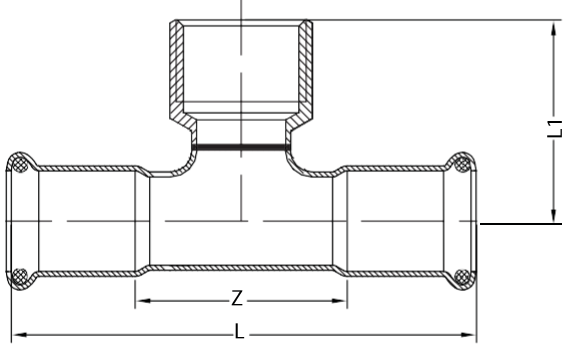
FEMALE TEE	EPDM	Gas	FKM	Size	L	Z	L1
	E3215012	G3215012	F3215012	15x1/2	64	24	43
	E3222012	G3222012	F3222012	22x1/2	74	32	46
	E3222034	G3222034	F3222034	22x3/4	74	32	48
	E3228012	G3228012	F3228012	28x1/2	84	38	51
	E3228034	G3228034	F3228034	28x3/4	84	38	53
	E3228100	G3228100	F3228100	28x1	84	38	56
	E3235012	G3235012	F3235012	35x1/2	100	48	54
	E3235034	G3235034	F3235034	35x3/4	100	48	
	E3235114	G3235114	F3235114	35x11/4	100	48	60
	E3242012	G3242012	F3242012	42x1/2	116	54	63
	E3242034	G3242034	F3242034	42x3/4	116	54	
	E3242112	G3242112	F3242112	42x11/2	116	54	63
	E3254012	G3254012	F3254012	54x1/2	138	68	63
	E3254034	G3254034	F3254034	54x3/4	138	68	
E3254200	G3254200	F3254200	54x2	138	68	74	

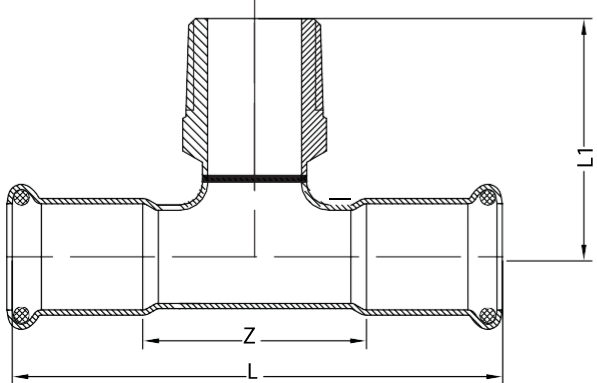
MALE TEE	EPDM	Gas	FKM	Size	L	Z	L1
	E3315012	G3315012	F3315012	15x1/2	64	24	43
	E3322012	G3322012	F3322012	22x1/2	74	32	46
	E3322034	G3322034	F3322034	22x3/4	74	32	48
	E3328012	G3328012	F3328012	28x1/2	84	38	51
	E3328034	G3328034	F3328034	28x3/4	84	38	53
	E3328100	G3328100	F3328100	28x1	84	38	56
	E3335012	G3335012	F3335012	35x1/2	100	48	54
	E3335114	G3335114	F3335114	35x11/4	100	48	60
	E3342012	G3342012	F3342012	42x1/2	116	54	63
	E3342112	G3342012	F3342012	42x11/2	116	54	63
	E3354012	G3354012	F3354012	54x1/2	138	68	63
	E3354200	G3354200	F3354200	54x2	138	68	74

Please reference EPDM, Gas, or FKM product codes when ordering fittings.

REDUCING TEE		EPDM	Gas	FKM	Size	L	Z	L1	Z1
	E3102215	G3102215	F3102215	22x15	74	32	45	25	
	E3102815	G3102815	F3102815	28x15	84	38	48	28	
	E3102822	G3102822	F3102822	28x22	84	38	50	29	
	E3103515	G3103515	F3103515	35x15	100	48	50	30	
	E3103522	G3103522	F3103522	35x22	100	48	53	32	
	E3103528	G3103528	F3103528	35x28	100	48	55	32	
	E3104215	G3104215	F3104215	42x15	116	54			
	E3104222	G3104222	F3104222	42x22	116	54	56	35	
	E3104228	G3104228	F3104228	42x28	116	54			
	E3104235	G3104235	F3104235	42x35	116	54	61	35	
	E3105415	G3105415	F3105415	54x15	138	68			
	E3105422	G3105422	F3105422	54x22	138	68	62	41	
	E3105428	G3105428	F3105428	54x28	138	68	64	41	
	E3105435	G3105435	F3105435	54x35	138	68	61	41	
	E3105442	G3105442	F3105442	54x42	138	68	71	40	
	E3107642	G3107642	F3107642	76.1x42	238	124	82	52	
	E3107654	G3107654	F3107654	76.1x54	238	124	93	57	
	E3108954	G3108954	F3108954	88.9x54	265	135	100	67	
	E3108976	G3108976	F3108976	88.9x76.1	265	135	125	65	
	E3110854	G3110854	F3110854	108x54	310	165	112	75	
E3110876	G3110876	F3110876	108x76.1	310	165	142	85		
E3110889	G3110889	F3110889	108x88.9	310	165	147	66		
45° BEND		EPDM	Gas	FKM	Size	L	Z		
	E4000015	G4000015	F4000015	15	31	11			
	E4000022	G4000022	F4000022	22	35	14			
	E4000028	G4000028	F4000028	28	40	17			
	E4000035	G4000035	F4000035	35	46	20			
	E4000042	G4000042	F4000042	42	56	25			
	E4000054	G4000054	F4000054	54	67	32			
	E4000076	G4000076	F4000076	76.1	112	55			
	E4000089	G4000089	F4000089	88.9	120	62			
	E4000108	G4000108	F4000108	108	145	72			
	CROSSOVER		EPDM	Gas	FKM	Size			
	E7400015	G7400015	F7400015		15				
	E7400022	G7400022	F7400022		22				
	E7400028	G7400028	F7400028		28				

Please reference EPDM, Gas, or FKM product codes when ordering fittings.

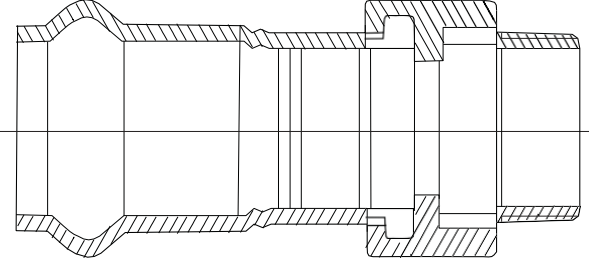
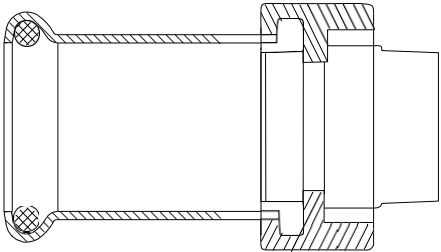
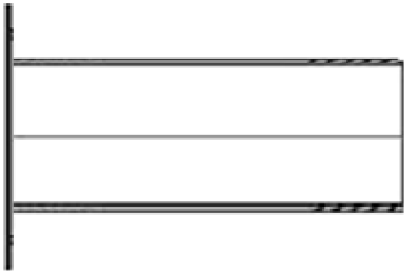

45° BEND WITH PLAIN END	EPDM	Gas	FKM	Size	L	L1	Z
	E4100015	G4100015	F4100015	15	32	38	15
	E4100022	G4100022	F4100022	22	36	42	16
	E4100028	G4100028	F4100028	28	41	46	18
	E4100035	G4100035	F4100035	35	46	52	19
	E4100042	G4100042	F4100042	42	56	63	19
	E4100054	G4100054	F4100054	54	67	73	21
	E4100076	G4100076	F4100076	76			
	E4100089	G4100089	F4100089	89			
	E4100108	G4100108	F4100108	108			
CAP	EPDM	Gas	FKM	Size	L	Z	
	E5000015	G5000015	F5000015	15	35	15	
	E5000022	G5000022	F5000022	22	37	16	
	E5000028	G5000028	F5000028	28	41	18	
	E5000035	G5000035	F5000035	35	45	19	
	E5000042	G5000042	F5000042	42	50	19	
	E5000054	G5000054	F5000054	54	56	21	
	E5000076	G5000076	F5000076	76			
	E5000089	G5000089	F5000089	89			
	E5000108	G5000108	F5000108	108			
FLANGE CONNECTOR DIN	EPDM	Gas	FKM	Size	PCD	Bolts	
	E6050054	G6050054	F6050054	54	125mm	4	
	E6076065	G6076065	F6076065	76.1	145mm	4	
	E6080089	G6080089	F6080089	88.9	160mm	8	
	E6100108	G6100108	F6100108	108	180mm	8	
FLANGE CONNECTOR TABLE E	EPDM	Gas	FKM	Size	PCD	Bolts	
	E6000054	G6000054	F6000054	54	114mm	4	
	E6000076	G6000076	F6000076	76.1	127mm	4	
	E6000089	G6000089	F6000089	88.9	146mm	4	
	E6000108	G6000108	F6100108	108	178mm	8	

Please reference EPDM, Gas, or FKM product codes when ordering fittings.

MALE UNION ADAPTOR		EPDM	Gas	FKM	Size
	E1815012	G1815012	F1815012		15x1/2
	E1822034	G1822034	F1822034		22x3/4
	E1828100	G1828100	F1828100		28x1
	E1835114	G1835114	F1835114		35x1 1/4
	E1842112	G1842112	F1842112		42x1 1/2
	E1854200	G1854200	F1854200		54x2
CROX ADAPTOR		Product Code			Size
	E7215012			15x1/2	
	E7222034			22x3/4	
	E7228100			28x1	
NECK RING		Product Code			Size
	E6200054			54	
	E6200076			76	
	E6200088			88	
	E6200108			108	

Please reference EPDM, Gas, or FKM product codes when ordering fittings.



O-RINGS





HNBR YELLOW GAS O-RING	Product Code	Size
	G9000015	15mm
	G9000022	22mm
	G9000028	28mm
	G9000035	35mm
	G9000042	42mm
	G9000054	54mm
	G9000076	76.1mm
	G9000088	88.9mm
	G9000108	108mm
FKM RED INDUSTRIAL O-RING	Product Code	Size
	F9200015	15mm
	F9200022	22mm
	F9200028	28mm
	F9200035	35mm
	F9200042	42mm
	F9200054	54mm
	F9200076	76.1mm
	F9200088	88.9mm
	F9200108	108mm
EPDM CHLORAMINE RESIST BLACK O-RING	Product Code	Size
	E9300015	15mm
	E9300022	22mm
	E9300028	28mm
	E9300035	35mm
	E9300042	42mm
	E9300054	54mm
	E9300076	76.1mm
	E9300088	88.9mm
	E9300108	108mm

MUNSEN RINGS

STAINLESS STEEL MUNSEN RING		Product Code	Clamping Range	Packing Units	Min. Torque	FKN	Thread
	0806015S	15-19	150	80	1.2	M10	
	0806021S	21-23	100	80	1.2	M10	
	0806026S	26-28	100	80	1.2	M10	
	0806032S	32-35	100	80	1.2	M10	
	0815038S	38-45	50	80	1.2	M10	
	0815048S	48-56	50	80	1.2	M10	
	0815074S	74-80	50	80	1.2	M10	
	0815083S	83-91	50	80	1.2	M10	
	0815108S	108-114	25	90	1.5	M10	
ZINC MUNSEN RING		Product Code	Clamping Range	Packing Units	Min. Torque	FKN	Thread
	0806015Z	15-19	150	80	1.2	M8/M10	
	0806021Z	21-23	100	80	1.2	M8/M10	
	0806026Z	26-28	100	80	1.2	M8/M10	
	0806032Z	32-35	100	80	1.2	M8/M10	
	0815038Z	38-45	50	80	1.2	M8/M10	
	0815048Z	48-56	50	80	1.2	M8/M10	
	0815074Z	74-80	50	80	1.2	M8/M10	
	0815083Z	83-91	50	80	1.2	M8/M10	
	0815108Z	108-114	25	90	1.5	M10	
DACROMET MUNSEN RING		Product Code	Clamping Range	Packing Units	Min. Torque	FKN	Thread
	0806015D	15-19	150	80	1.2	M8/M10	
	0806021D	21-23	100	80	1.2	M8/M10	
	0806026D	26-28	100	80	1.2	M8/M10	
	0806032D	32-35	100	80	1.2	M8/M10	
	0815038D	38-45	50	80	1.2	M8/M10	
	0815048D	48-56	50	80	1.2	M8/M10	
	0815074D	74-80	50	80	1.2	M8/M10	
	0815083D	83-91	50	80	1.2	M8/M10	
	0815108D	108-114	25	90	1.5	M10	

TOOLS

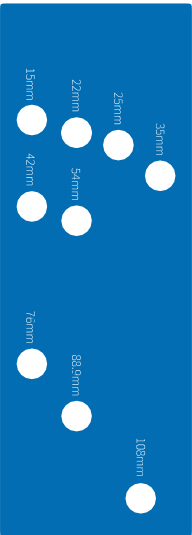
MAYER PRESS TOOL		Product Code	Size
	T0050010		15-54mm
	Includes, press tool, charger, 2 batteries, and sling in a durable plastic box. Note: No press jaws included.		
MAYER PRESS JAWS & RINGS		Product Code	Size
	Jaw	T0050015	15
	Jaw	T0050022	22
	Jaw	T0050028	28
	Jaw	T0050035	35
	Press adaptor	T0050040	
	Ring	T0050042	42
	Ring	T0050054	54
	Ring	T0050110	76.1
	Ring	T0050115	88.9
	Ring	T0050120	108
MAYER ELECTRIC HYDRAULIC PUMP		Product Code	Size
	T0050099		76.1-108mm
	Electric hydraulic pump complete with electrics, hoses, press rings and adaptors for sizes 76.1-108mm.		

PIPE CUTTER		Product Code	Size
	T0050655		12-54mm
DEBURRER		Product Code	Size
 	T0050800		15-35mm
	T0050810		15-54mm
	T001000	deburring pencil	
PRESS & DEPTH INDICATORS & O-RING HOOK		Product Code	Size
  	Press depth indicator	T0050200	15-54mm
	Press fitting check	T0050165	15-28mm
	O-ring removal hook	T0050001	

SECTION 4

PRESS JOINTING

Correct cutting and fitting of the Mayer stainless steel pipe system is essential to achieve air and watertight joints.

The techniques and tools required for appropriately installed pipe systems are easily acquired and should be familiar to tradesmen who have worked with copper piping systems, with some special allowances for the specific properties of stainless steel.

By following simple guidelines and using approved electronic tools, Mayer stainless steel pipe systems are rapidly implemented, deliver leak-free performance and will last the lifetime of the building.

GUIDELINES, TOOL USE & PREPARATION

Sizes 15, 22, 28 & 35



Cutting: Pipes are cut to length with approved burr-free cutters. Oxy-acetylene torches and abrasive cut-off wheels are not suitable. Pipes are cut at right angles to their axis, using a pipe cutter or fine-tooth saw. Measured lengths must take into account the depth of insertion into the fitting.



Deburring: Carefully deburr all pipe cuts inside and outside with a manual or electric deburring tool. Remove any cutting residue (swarf) to avoid damage to the O-ring upon insertion of the pipe to the fitting, ensuring a watertight joint.



Assess mark insertion depth: Correctly inserted joints require marking the pipe with a fine-point felt-tip pen where it meets the fitting for verification of full insertion. The following depths apply:
 15 mark at 21mm
 22 mark at 21mm
 28 mark at 24mm
 35 mark at 26mm



Assemble fitting on tube: Before assembling the fittings, check the positioning of the O-ring. If necessary, lubricate the O-ring with water or talc to ease insertion of the pipe. Never use oils, greases, glues or other similar substances. The pipe is inserted in the fitting with a slight rotating motion until it hits the stop. Check the pipe against the felt pen mark to ensure complete insertion.



Press tool & jaw: Press tools are to be equipped with M-shaped profile jaw attachments or a pressing jaw which corresponds to the diameter of the fitting being pressed. Retract the lock pin, position the jaw in the tool head and fully engage the lock pin.



Position press jaw: Squeezing the two ends together to open the jaw. Position the jaw over the fitting, creating a perfect fit with the internal channel of the jaw around the toroidal seat of the fitting. Release the jaw and check for alignment.



Press joint: Squeeze the trigger to initiate the press cycle, holding it down for the full duration of the press cycle. The cycle must not be interrupted, and the tool will alert you (by beeping or the LED coming on) if the joint is unsuccessful. Press the reset button if the hydraulic ram is interrupted mid-cycle to manually override the automatic reset function.

Check the LED warning light after each press to ensure sufficient battery power for the next press. More information is available in the tool's trouble-shooting guide.



GUIDELINES, TOOL USE & PREPARATION

Sizes 42, 54, 76.1, 88.9 & 108



1

Cutting and deburring: Cutting and deburring pipes with these diameters is done in the same way as other sizes (see previous page).



2

Witness mark insertion depth: Correctly inserted joints are ensured by marking the pipe with a fine-point felt-tip pen. The following depths apply:

- 42 mark at 33mm
- 54 mark at 36mm
- 76.1 mark at 55mm
- 88.9 mark at 63mm
- 108 mark at 78mm



3

Assemble fitting on tube: Before assembling the fittings, check the positioning of the O-ring. If necessary, lubricate the O-ring with water or talc to ease insertion of the pipe. Never use oils, greases, glues or other similar substances. The pipe is inserted in the fitting with a slight rotating motion until it hits the stop. Check the pipe against the felt pen mark to ensure complete insertion.



4

Assemble the adaptor to the press tool



5

Attach press collar: Use the M-shaped profile pressing collar which corresponds to the diameter of the fitting being pressed. Open the jaw and position the jaw around the fitting.



6

Connect press tool: Retract the lock pin, engage the adaptor and fully engage the lock pin.



7

Press joint: Squeeze the trigger to initiate the press cycle, holding it down for the full duration of the press cycle. The cycle must not be interrupted, and the tool will alert you (by beeping or the LED coming on) if the joint is unsuccessful. Press the reset button if the hydraulic ram is interrupted mid-cycle to manually override the automatic reset function.

Check the LED warning light after each press to ensure sufficient battery power for the next press. More information is available in the tool's trouble-shooting guide.



SECTION 5

INSTALLATION

Making press joints which last requires a calculation to account for the linear expansion of stainless steel pipe systems when used for warm and hot water applications. When fitting stainless pipes through footings or floors, appropriate insulating materials must be used to ensure the longevity and performance of the pipe system.

Similarly, the correct choice of fasteners will deliver a robust and fit-for-purpose pipe system.

LINEAR EXPANSION

Linear expansion of stainless steel pipes is influenced by the difference in operating temperature to the installation temperature, and any heat to which the pipes are exposed. Cold water pipes have little to no linear expansion. However, with warm water and heating installations, linear expansion must be calculated and compensated for to avoid damage to the joints and fatigue failures in the system.

The following linear expansion formula is applied to avoid stress between the joints:

$$\Delta L = a \times L \times \Delta T \div 1000$$

ΔL = linear expansion

a = coefficient of linear expansion of Stainless Steel 16.5 mm/mK

L = pipe length

ΔT = temperature Difference

Example

The thermal expansion of 10m subjected to a temperature variation of 65°C.

$$\Delta L = 16.5 \times 10 \times 65 \div 1000 = 10.7\text{mm}$$

Thermal expansion " ΔL " of Mayer stainless systems

Tube Length L (m)	Temperature Differential ΔT °C						
	10	20	30	40	50	60	70
1	0.17	0.33	0.50	0.66	0.83	0.99	1.16
2	0.33	0.66	0.99	1.32	1.65	1.98	2.31
3	0.50	0.99	1.49	1.98	2.48	2.97	3.47
4	0.66	1.32	1.98	2.64	3.30	3.96	4.62
5	0.83	1.65	2.48	3.30	4.13	4.95	5.72
6	1.00	1.98	2.97	3.96	4.95	5.94	6.93
7	1.16	2.31	3.47	4.62	5.78	6.93	8.09
8	1.33	2.64	3.96	5.28	6.60	7.92	9.24
9	1.49	2.97	4.46	5.94	7.43	8.91	10.40
10	1.66	3.30	4.95	6.60	8.25	9.90	11.55



Stainless steel tubes above 28mm can be compensated with the use of stainless bellows. These are corrugated, extendable, and compensate for expansion.

Note: ensure that the bellow installed allows for the expansion required within the pipe run and that it is within deflection tolerances.

FASTENING

Munsen rings for Mayer stainless pipe must correspond with the external pipe diameter. Because the fastening material must not damage the pipe surface, rubber-lined pipe clamps are ideal. See recommended munsen rings in the product range. **Note:** ferrous clamps (unlined) are unsuitable for use on stainless steel.

Different fastening material and techniques are necessary for a fixed point or a sliding point.

FIXED POINT

The fixed points of the pipelines are divided into individual sections. This avoids uncontrolled pipe movement. In principle, fixed points must be measured and installed to the forces of expansion of the stainless steel pipe as well as probable additional loads are absorbed. **Note:** ensure pipe munsen rings are not fastened over press connections.

RISERS

Expansion must be allowed for on vertical heating risers every 20 metres. An expansion loop or expansion bellows can be used. Ensure riser is firmly secured with fixed and sliding points as required. **Note:** ensure pipe munsen rings are not fastened over pressconnections.

SLIDING POINTS

Sliding clamps must permit damage-free axial pipe movement. When locating a sliding clamp, make sure the movements of the pipelines are unimpeded by fittings or armatures installed close by.

SUPPORT INTERVALS

Pipe/Horizontal/Vertical in metres: (all temperature installations)

Pipe	15	22	28	35	42	54	79.1	88.9	108
Horizontal	1.5	2	2.3	2.5	2.8	3	3.5	3.7	4
Vertical	1.5	2.5	2.5	3	3.3	3.5	4.2	4.5	5

DISTANCE BETWEEN FITTINGS

If press fittings are installed too close together, they can compromise joint seals. Therefore, minimum distances are specified to ensure proper use of the pressing tools and to ensure the correct formation of watertight joints.

Pipe Size	Distance
15 to 35	10mm
42 to 54	20mm
76.1 to 108	30mm

EXPANSION & BENDING LEGS

Suitable munsen rings must be used when installing Mayer pipe. For open installed pipes, the linear expansion ΔL is taken into consideration on planning. The pipe route must be planned and installed so the pipe is free moving within the determined expansion. The maximum distances between bending legs should not exceed 30 metres of straight pipelines and 20 metres in risers.

In most cases, direction changes can be used to compensate for linear expansion. The length of a bending side must be calculated as below:

Minimum distance 'X' to fixed point to allow for linear expansion

Tube Diameter d (mm)	Linear Expansion						
	10mm	20mm	30mm	40mm	50mm	60mm	70mm
15	0.57	0.80	0.98	1.13	1.27	1.39	1.50
22	0.69	0.97	1.19	1.37	1.54	1.68	1.82
28	0.77	1.10	1.34	1.55	1.73	1.90	2.05
35	0.87	1.22	1.50	1.73	1.94	2.12	2.29
42	0.95	1.35	1.64	1.90	2.12	2.32	2.51
54	1.08	1.52	1.86	2.15	2.41	2.63	2.85
76.1	1.28	1.81	2.21	2.55	2.86	3.13	3.38
108	1.52	2.15	2.63	3.04	3.40	3.73	4.02

EXPANSION LOOP

If the linear expansion cannot be compensated through a change in direction, it may be necessary to install an expansion loop with long and straight pipelines. In addition to the length of the bending side L, the width of the pipe bend A must be considered.

Symbol Meaning

A Width of the expansion loop (mm)

SA Safety distance 150mm

The pipe bend A is calculated according to the following formula: $A = 2 \times \Delta L + SA$

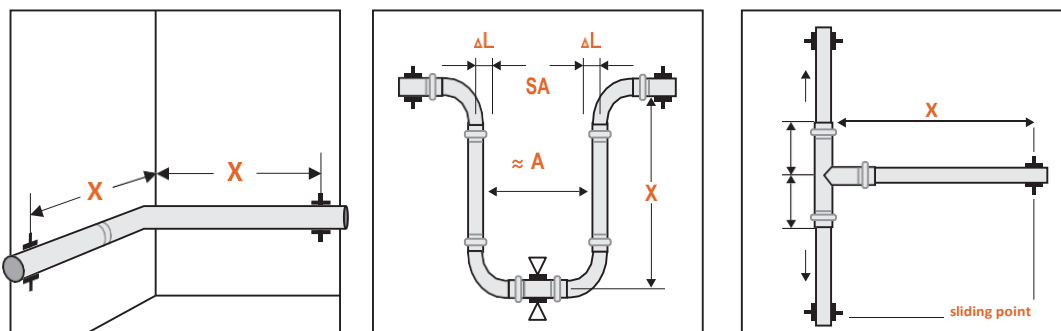

STORAGE & HANDLING

Take care when storing Mayer stainless steel pipes and fittings. The products must be stored in a dry, clean environment free of corrosive gas or other materials, where they cannot be struck by sharp objects, collide with other materials, or be dropped or thrown. Avoid cluttering and mixing with other materials.

Should pipes become coated or stained by oil, clean immediately with attention to pipe ends and the rubber O-rings of the press fitting.

When transporting pipes, stack neatly in the box and cover to protect against rain and other pollution.

CORROSION & 316L PIPE & FITTINGS

Stainless 316L is well known for its resistance to corrosion. There are aspects on internal and external corrosion that need to be considered in application and installation. Key aspects are:

- Chloride levels exceeding safe levels of use with stainless 316L, both internal with liquids and surface. Sterilisation and dosing where free chlorines/additives far exceed safe levels. Be aware excessive heat/steam/high temperature grinding/heat bending may lead to stress, cracking and forms of corrosive influence and can lead to material failure.
- Thermal lagging/acoustic lagging, mastics etc that can contain chlorides need to be considered.
- Connecting stainless directly to carbon steel ferrous materials.

For all applications involving the above contact Mayer NZ technical representatives.

EARTHING

Stainless steel pipes and fittings create continuous electrically conducting connections and equipotential bonding. This must be addressed in accordance with relevant codes and standards.

CONNECTION OF STAINLESS STEEL PIPES WITH DIFFERENT MATERIALS

Care must be taken when connecting stainless steel pipes with pipes manufactured from other materials. Some can be connected directly, others will cause electrochemical or galvanic corrosion. Manage this risk by introducing a non-ferrous joint between the two metals or eliminate it by using non-ferrous spacers at least 50mm in length. Where pipes manufactured from different materials have matching diameters and pipe fittings, they can be connected.

THERMAL/ACOUSTIC INSULATION MATERIALS

Modern foam insulation materials can be used, **but it must not contain soluble chloride ions and/or bromides exceeding 0.05% by weight**. Traditional thermal insulation materials can also be used, including pearl padding and glass wool. These will not adversely affect the Mayer stainless steel pipe.



INSTALLATION

Select appropriate thermal insulation materials based on conditions of use and the temperatures of the connecting position of coated and insulation pipes. The cover and insulation layers should be turned over at the end of the socket.

When the installation is ready, wrap the interface parts and fittings in the anti-condensation material or insulation materials.

After installation of the non-coated pipe and coated insulation pipe, conduct an initial inspection before adding the insulation material. Subsequently, conduct the hydraulic test.

FIRE PROTECTION

Mayer stainless 316L pipes and fittings are metallic and non-flammable and therefore do not contribute to fire propagation. Ensure the installation is in accordance with fire protection requirements of national building codes. As with insulation materials and guidelines, ensure any mastics/foams/smoke stops will not react with the pipe system (chlorides/bromides etc).

HEAT TRACE

When installing heat trace or Mayer stainless press systems ensure that the manufacturer's instructions for the installation are followed in all aspects.

ANTIFREEZE

Where pipe installations are made in cold or freezing areas, anti-freeze measures are necessary. Avoid allowing the installation to freeze, which can cause damage through expansion.

- Assess the coldest temperature in winter, set the frost level and insulation layer thickness
- There should be no gap between the batt of insulation material, or between the insulation material and the pipe
- In windy places and areas rarely exposed to the sun, use thickened insulation materials when installing the pipe
- Note that smaller pipes will freeze more easily and more rapidly

PRESSURE TESTING & FLUSHING

Potable and heating installations are tested using water at a pressure of 1.5 times the operating pressure as a minimum testing.

For dry tests with compressed air, only oil-free compressed air is to be used to prevent residue in the pipe works. Dry tests are conducted in two phases: a low pressure seal test then followed by a load test.

WARNING: After flushing and testing, all stainless systems must be kept full of clean potable water. Failure to do so will increase the risk of pitting corrosion.



MAYER TEST RECORD

Test record for Mayer pipe installations where no pressure limitations are present.

Description of the Installation

Address:
.....
.....

Test pressure:
.....
.....

Highest point: m

Time tested started:

Time tested finished:

Test period: (minutes)

Client:
.....
.....

Contractor:
.....
.....

Notes:
.....
.....
.....
.....
.....
.....
.....

Signature/stamp:

Reg. installer number:

Mayer NZ must receive this information **within 3 months** of the installation for the warranty to be valid.
Please consult with your local area Council as they may require a copy of the test results for their records.



INSTALLING STAINLESS PIPES THROUGH FOOTINGS OR FLOORS

For these installations, the Mayer stainless steel pipe is not able to be cast directly into concrete, and must be coated in elastic insulating materials for movement (**chloride free material**). Chased pipe must not be in direct contact with plaster.

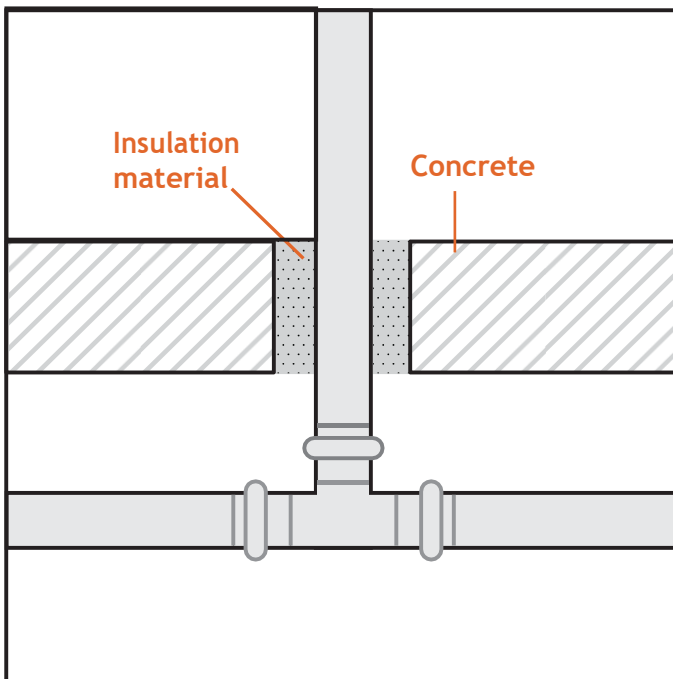

Tubes in ceiling penetrations

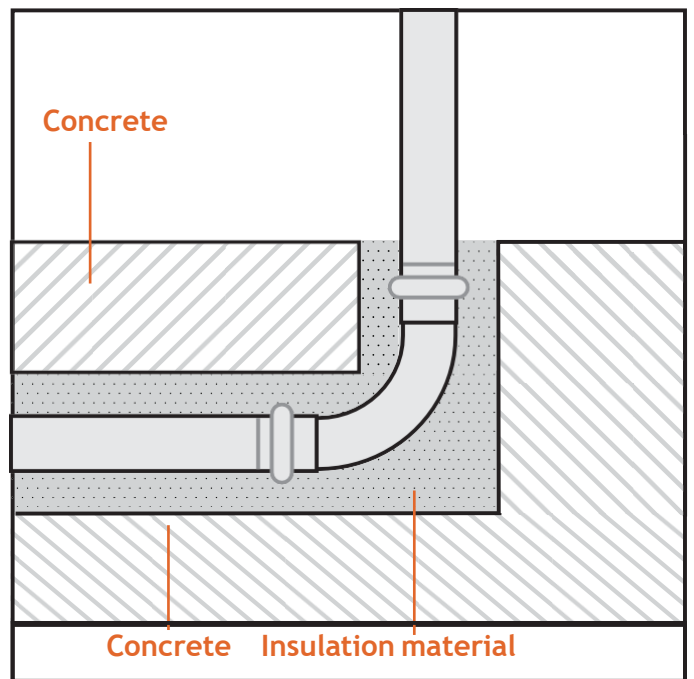

Tubes under composition floor (in thermal and footfall acoustic insulation)

CHEMICAL COMPATIBILITY & O-RINGS

Fluid	AISI 316L	EPDM	HNBR	FKM-FPM
Acetic acid 20%	Y	Y	N	N
Acetone 100%	Y	Y	N	N
Acetylene	Y	Y	Y	Y
Ammonia dry	Y	Y	Y	N
Ammonium chloride 1%	Y	Y	Y	Y
Ammonium nitrate 10÷50%	Y	Y	Y	Y
Ammonium phosphate 10%	N	Y	Y	N
Ammonium sulfate 10%	N	Y	Y	N
Aniline	Y	Y	Y	N
Aqua regia, aqua fortis	Y	N	N	Y
Battery acid	Y	Y	N	Y
Benzene	Y	N	N	Y
Boric acid 5%	Y	Y	Y	Y
Butane	Y	N	Y	Y
Butanol	Y	Y	N	Y
Calcium Hydroxide ≤ 10°C	N	Y	Y	Y
Calcium Hypochlorite	N	Y	Y	Y
Carbon dioxide	Y	Y	Y	Y
Caustic soda ≤ 50%	Y	Y	Y	N
Chlorine (dry)	Y	Y	Y	Y
Citric acid 5%	Y	Y	Y	Y

Fluid	AISI 316L	EPDM	HNBR	FKM-FPM
Compressed air	Y	N	Y	Y
Copper chloride	N	Y	Y	Y
Copper nitrate	Y	Y	Y	Y
Copper sulfate 10%	Y	Y	Y	Y
Photo developer/fixing bath	Y	Y	Y	Y
Engine oil	Y	N	Y	Y
Ethane	Y	N	Y	Y
Ethylene glycol	Y	Y	Y	Y
Ethylene Oxide	Y	N	N	N
Ferric chloride, watery	N	Y	Y	Y
Ferric sulfate	N	Y	Y	Y
Formaldehyde	Y	Y	Y	N
Formic acid	N	Y	N	N
Gas oil	Y	N	Y	Y
Gasoline	Y	N	Y	Y
Gear oil	Y	N	Y	Y
Hexane	Y	Y	Y	Y
Hydrochloric acid 100%	N	N	Y	Y
Hydrogen fluoride	N	N	N	N
Hydrogen peroxide 10%	Y	Y	N	Y
Kerosene	Y	N	Y	Y

Y: Yes, safe to use
N: No, do not use

CHEMICAL COMPATIBILITY & O-RINGS

Fluid	AISI 316L	EPDM	HNBR	FKM-FPM
Linseed oil	Y	N	N	Y
Lubricating oils	Y	N	Y	Y
Machine oil	Y	N	Y	Y
Magnesium chloride ≤ 20%	Y	Y	Y	Y
Magnesium hydroxide 100°C	N	Y	Y	Y
Magnesium sulfate < 40%	Y	Y	Y	Y
Methane	Y	N	Y	Y
Methanol	Y	Y	Y	N
Mineral oil	Y	N	Y	Y
Naphtha	Y	N	Y	Y
Naphthalene	Y	N	N	Y
Nickel chloride 10÷30%	N	Y	Y	Y
Nickel sulfate	Y	Y	Y	Y
Nitric acid ≤ 20%	Y	N	Y	Y
Paraffin	Y	N	Y	Y
Phosphoric acid	Y	Y	N	Y
Potassium chloride	Y	Y	Y	Y
Potassium hydroxide ≤ 50°C	N	Y	Y	N
Potassium sulfate 10%	Y	Y	Y	Y
Propane (liquefied)	Y	N	Y	Y
Prussic acid	N	Y	N	Y

Fluid	AISI 316L	EPDM	HNBR	FKM-FPM
Sea water	Y	Y	Y	Y
Sodium bicarbonate	Y	Y	Y	Y
Sodium chloride 5%	Y	Y	Y	Y
Sodium nitrate ≤ 40%	Y	Y	Y	Y
Sodium phosphate	N	Y	Y	Y
Sodium sulfate 10%	Y	Y	Y	Y
Sulfuric acid 10% 60°C	N	Y	N	Y
Sulfuric acid, smoking	N	N	N	Y
Sulfuric acid 100%, moist	N	N	N	Y
Sulphur dioxide (dry)	N	Y	N	Y
Tannin	Y	Y	N	Y
Tanning agents for leather	Y	Y	Y	Y
Tartaric Acid 10% 100°C	Y	Y	N	Y
Toluol 20°C	Y	Y	N	N
Trichloroethylene	N	N	N	Y
Turpentine	N	N	Y	Y
Water ≤ 100°C	Y	Y	Y	Y
Water, deionised	Y	Y	Y	Y
Water, distilled	Y	Y	Y	Y
Zinc chloride	Y	Y	Y	Y
Zinc sulfate 10%	Y	Y	Y	Y



PRESSURE LOSS

Mayer stainless steel tube friction pressure loss @ 10°C							
OD	15mm		22mm				
Bore mm	13mm		19.6mm				
V l/s	R (Mbar)	V (M/S)	R (Mbar)	V (M/S)			
0.07	3.97	0.53	0.57	0.23			
0.08	4.99	0.60	0.72	0.27			
0.09	6.12	0.68	0.88	0.30			
0.10	7.34	0.75	1.05	0.33			
0.12	10.06	0.90	1.44	0.40			
0.14	13.16	1.05	1.88	0.46			
0.16	16.61	1.21	2.37	0.53			
0.18	20.40	1.36	2.90	0.60			
0.20	24.54	1.51	3.49	0.66			
0.22	29.00	1.66	4.12	0.73			
0.24	33.79	1.81	4.79	0.80			
0.26	38.91	1.96	5.51	0.86			
0.28		Velocities above 2m/s are not advised	6.27	0.93			
0.30			7.07	0.99			
0.32			7.92	1.06			
0.34			8.81	1.13			
0.36			9.74	1.19			
0.38			10.71	1.26			
0.40			11.72	1.33			
0.42			12.77	1.39			
0.44			13.87	1.46			
0.46			15.00	1.52			
0.48			16.17	1.59			
0.50			17.37	1.66			
0.52			18.62	1.72			
0.54			19.90	1.79			
0.56			21.23	1.86			
0.58			22.59	1.92			
0.60		23.99	1.99				
0.62				Velocities above 2m/s are not advised			
0.64							
0.66							
0.68							
0.70							

Mayer stainless steel tube friction pressure loss @ 10°C (continued)

OD	28mm		35mm		42mm		54mm	
Bore mm	25.6mm		32mm		39mm		51mm	
V l/s	R (Mbar)	V (M/S)	R (Mbar)	V (M/S)	R (Mbar)	V (M/S)	R (Mbar)	V (M/S)
0.25	1.45	0.49	0.50	0.31	0.20	0.21	0.06	0.12
0.30	1.99	0.58	0.69	0.37	0.27	0.25	0.08	0.15
0.35	2.60	0.68	0.90	0.44	0.35	0.29	0.10	0.17
0.40	3.29	0.78	1.14	0.50	0.45	0.33	0.13	0.20
0.45	4.04	0.87	1.40	0.56	0.55	0.38	0.15	0.22
0.50	4.86	0.97	1.68	0.62	0.66	0.42	0.18	0.24
0.55	5.75	1.07	1.99	0.68	0.78	0.46	0.22	0.27
0.60	6.70	1.17	2.31	0.75	0.90	0.50	0.25	0.29
0.65	7.72	1.26	2.66	0.81	1.04	0.54	0.29	0.32
0.70	8.80	1.36	3.03	0.87	1.18	0.59	0.33	0.34
0.75	9.94	1.46	3.43	0.93	1.33	0.63	0.37	0.37
0.80	11.14	1.55	3.84	0.99	1.49	0.67	0.42	0.39
0.85	12.40	1.65	4.27	1.06	1.66	0.71	0.46	0.42
0.90	13.73	1.75	4.73	1.12	1.84	0.75	0.51	0.44
0.95	15.11	1.85	5.20	1.18	2.02	0.80	0.56	0.47
1.00	16.55	1.94	5.70	1.24	2.21	0.84	0.62	0.49
1.25		Velocities above 2m/s are not advised	8.46	1.55	3.28	1.05	0.92	0.61
1.50			11.70	1.87	4.54	1.26	1.26	0.73
1.75				Velocities above 2m/s are not advised	5.97	1.46	1.66	0.86
2.00					7.57	1.67	2.10	0.98
2.25					9.34	1.88	2.59	1.10
2.50						3.12	1.22	
2.75						Velocities above 2m/s are not advised	3.70	1.35
3.00							4.32	1.47
3.25							4.98	1.59
3.50							5.69	1.71
3.75							6.44	1.84
4.00						7.22	1.96	
4.25							Velocities above 2m/s are not advised	
4.50								
4.75								
5.00								

Mayer stainless steel tube friction pressure loss @ 10°C (continued)									
OD	76.1mm		88.9mm		108mm				
Bore mm	72.1mm		84.9mm		104mm				
V l/s	R (Mbar)	V (M/S)	R (Mbar)	V (M/S)	R (Mbar)	V (M/S)			
1.50	0.24	0.37	0.10	0.26	0.04	0.18			
1.75	0.39	0.43	0.13	0.30	0.06	0.21			
2.00	0.40	0.49	0.17	0.35	0.07	0.24			
2.25	0.49	0.55	0.21	0.39	0.09	0.26			
2.50	0.60	0.61	0.26	0.44	0.10	0.29			
2.75	0.70	0.67	0.30	0.48	0.12	0.32			
3.00	0.81	0.73	0.35	0.53	0.14	0.35			
3.50	1.08	0.86	0.47	0.62	0.19	0.41			
4.00	1.37	0.98	0.59	0.71	0.24	0.47			
4.50	1.70	1.10	0.73	0.79	0.29	0.53			
5.00	2.05	1.22	0.88	0.88	0.35	0.59			
5.50	2.43	1.35	1.04	0.97	0.42	0.65			
6.00	2.84	1.47	1.22	1.06	0.49	0.71			
6.50	3.27	1.59	1.41	1.15	0.57	0.77			
7.00	3.74	1.71	1.61	1.23	0.65	0.82			
7.50	4.23	1.84	1.82	1.32	0.73	0.88			
8.00	4.75	1.96	2.05	1.41	0.82	0.94			
8.50		Velocities above 2m/s are not advised	2.28	1.50	0.91	1.00			
9.00			2.53	1.59	1.01	1.06			
9.50			2.79	1.68	1.12	1.12			
10.00			3.06	1.77	1.22	1.18			
11.00			3.34	1.85	1.45	1.29			
12.00			3.64	1.94	1.70	1.41			
13.00					Velocities above 2m/s are not advised	1.96	1.53		
14.00						2.24	1.65		
15.00				2.53		1.77			
16.00				2.85		1.88			
17.00					3.18	2.00			
18.00						Velocities above 2m/s are not advised			
19.00									
20.00									
21.00									
22.00									

Mayer stainless steel tube friction pressure loss @ 60°

OD	15mm		22mm					
Bore mm	13mm		19.6mm					
V l/s	R (Mbar)	V (M/S)	R (Mbar)	V (M/S)				
0.07	2.98	0.53	0.42	0.23				
0.08	3.77	0.60	0.54	0.27				
0.09	4.63	0.68	0.66	0.30				
0.10	5.58	0.75	0.79	0.33				
0.12	7.70	0.90	1.09	0.40				
0.14	10.11	1.05	1.42	0.46				
0.16	12.82	1.21	1.80	0.53				
0.18	15.81	1.36	2.22	0.60				
0.20	19.08	1.51	2.67	0.66				
0.22	22.62	1.66	3.16	0.73				
0.24	26.43	1.81	3.69	0.80				
0.26	30.51	1.96	4.25	0.86				
0.28		Velocities above 2m/s are not advised	4.85	0.93				
0.30			5.49	0.99				
0.32			6.15	1.06				
0.34			6.86	1.13				
0.36			7.59	1.19				
0.38			8.36	1.26				
0.40			9.17	1.33				
0.42			10.00	1.39				
0.44			10.87	1.46				
0.46			11.78	1.52				
0.48			12.71	1.59				
0.50			13.68	1.66				
0.52			14.68	1.72				
0.54			15.71	1.79				
0.56			16.77	1.86				
0.58			17.86	1.92				
0.60		18.99	1.99					
0.62				Velocities above 2m/s are not advised				
0.64								
0.66								

Mayer stainless steel tube friction pressure loss @ 60°C (continued)								
OD	28mm		35mm		42mm		54mm	
Bore mm	25.6mm		32mm		39mm		51mm	
V l/s	R (Mbar)	V (M/S)	R (Mbar)	V (M/S)	R (Mbar)	V (M/S)	R (Mbar)	V (M/S)
0.25	1.11	0.49	0.38	0.31	0.15	0.21	0.04	0.12
0.30	1.53	0.58	0.53	0.37	0.21	0.25	0.06	0.15
0.35	2.01	0.68	0.69	0.44	0.27	0.29	0.07	0.17
0.40	2.55	0.78	0.88	0.50	0.34	0.33	0.09	0.20
0.45	3.14	0.87	1.08	0.56	0.42	0.38	0.11	0.22
0.50	3.79	0.97	1.30	0.62	0.51	0.42	0.14	0.24
0.55	4.50	1.07	1.54	0.68	0.60	0.46	0.16	0.27
0.60	5.25	1.17	1.80	0.75	0.70	0.50	0.19	0.29
0.65	6.06	1.26	2.08	0.81	0.81	0.54	0.22	0.32
0.70	6.93	1.36	2.37	0.87	0.92	0.59	0.25	0.34
0.75	7.84	1.46	2.68	0.93	1.04	0.63	0.28	0.37
0.80	8.81	1.55	3.01	0.99	1.17	0.67	0.32	0.39
0.85	9.82	1.65	3.36	1.06	1.30	0.71	0.36	0.42
0.90	10.89	1.75	3.72	1.12	1.44	0.75	0.39	0.44
0.95	12.00	1.85	4.10	1.18	1.59	0.80	0.43	0.47
1.00	13.16	1.94	4.50	1.24	1.74	0.84	0.48	0.49
1.25		Velocities above 2m/s are not advised	6.72	1.55	2.59	1.05	0.71	0.61
1.50			9.34	1.87	3.60	1.26	0.99	0.73
1.75				Velocities above 2m/s are not advised	4.75	1.46	1.30	0.86
2.00					6.05	1.67	1.66	0.98
2.25					7.49	1.88	2.05	1.10
2.50						Velocities above 2m/s are not advised	2.48	1.22
2.75					2.95		1.35	
3.00					2.34		1.47	
3.25					3.99		1.59	
3.50					4.56		1.71	
3.75					5.17	1.84		
4.00					5.82	1.96		
4.25						Velocities above 2m/s are not advised		
4.50								
4.75								

Mayer stainless steel tube friction pressure loss @ 60°C (continued)								
OD	76.1mm		88.9mm		108mm			
Bore mm	72.1mm		84.9mm		104mm			
V l/s	R (Mbar)	V (M/S)	R (Mbar)	V (M/S)	R (Mbar)	V (M/S)		
1.50	0.19	0.37	0.08	0.26	0.03	0.18		
1.75	0.25	0.43	0.11	0.30	0.04	0.21		
2.00	0.32	0.49	0.14	0.35	0.05	0.24		
2.25	0.39	0.55	0.18	0.39	0.07	0.26		
2.50	0.47	0.61	0.22	0.44	0.08	0.29		
2.75	0.56	0.67	0.26	0.48	0.10	0.32		
3.00	0.65	0.73	0.30	0.53	0.11	0.35		
3.50	0.86	0.86	0.39	0.62	0.15	0.41		
4.00	1.10	0.98	0.51	0.71	0.19	0.47		
4.50	1.36	1.10	0.63	0.79	0.23	0.53		
5.00	1.64	1.22	0.76	0.88	0.28	0.59		
5.50	1.95	1.35	0.91	0.97	0.33	0.65		
6.00	2.28	1.47	1.07	1.06	0.39	0.71		
6.50	2.64	1.59	1.24	1.15	0.45	0.77		
7.00	3.02	1.71	1.43	1.23	0.52	0.82		
7.50	3.43	1.84	1.60	1.32	0.59	0.88		
8.00	3.85	1.96	1.81	1.41	0.66	0.94		
8.50		Velocities above 2m/s are not advised	2.03	1.50	0.73	1.00		
9.00			2.25	1.59	0.81	1.06		
9.50			2.49	1.68	0.90	1.12		
10.00			2.74	1.77	0.99	1.18		
11.00			3.27	1.94	1.17	1.29		
12.00				Velocities above 2m/s are not advised	1.37	1.41		
13.00					1.59	1.53		
14.00					1.82	1.65		
15.00					2.06	1.77		
16.00					2.32	1.88		
17.00					2.59	2.00		
18.00						Velocities above 2m/s are not advised		
19.00								
20.00								



SECTION 6

TRAINING & WARRANTY



TRAINING

Mayer NZ view training and technical support as an integral part of our installer support, ensuring our systems are as durable and long-lasting as possible. The quality of the installation determines how the system will perform. To assist in this process Mayer NZ runs a certified installer's training course for the installation and application of our 316L Stainless press jointed system.

Site support: Training also coincides with Mayer technical staff nationally supporting sites where and when required, also depending on the scope of the project this may not be required and/or may require multiple visits. Refresher training may be undertaken at the beginning of each project. This number is then documented on the pressure test certificate and used as a reference to validate our comprehensive warranty

3 STAGES OF TRAINING

STAGE 1: PRESS JOINTING

Covering health and safety, tooling, pipe preparation and jointing methodology. Those only completing stage 1 of the Mayer training process will be supplied with a certificate saying they have been trained to press joint the Mayer 316L Stainless system. Training is designed for staff providing labour on site.

STAGE 2: INSTALLATION BEST PRACTISE

Covering stage 1 and addressing temperature/pressure, bracketing/expansion, and pressure testing. The installation best practise training is valid for 3 years. Those trained will be issued with an installers card. This training is designed for senior tradespeople and 3rd year apprentices to assist with their training and understanding of Stainless press systems.

STAGE 3: POST CONSTRUCTION QA

Covering Mayer's QA requirements warranty, pressure testing, and documentation.

Mayer NZ also offers support to engineers and designers in general installation inquiries in the suitability and application of the Mayer 316L Stainless system. Training courses are held at our head office training centre in Auckland, our Christchurch centre and/or regionally conducted at the installer's facilities.

TOOL HIRE & SERVICING

The hire of press tooling when/if required will be part of our installer support. Sale and servicing of press tools is an essential part of our support service to our customers. We understand that down time is expensive so we endeavour to get your tools serviced and back to you as quickly as possible.





WARRANTY & LIFETIME STATEMENT

Mayer manufacture all 316L Stainless Steel pipes and fittings in accordance with; BS EN 10088-1:2005 (AIS316L). Mayer confirm a 25 year guarantee of service life in accordance with the permissible working pressure/temperature/application suitability as directed by the Mayer technical product manual. Within the scope of this Mayer will supply replacement pipe and fittings if damages are traceable to materials faults and defects. The system is designed for a 50 year service life, and guaranteed not to leak for 25 years.

LIABILITY WARRANTY

Furthermore within the scope of this, Mayer gives a 10 year guarantee which compensates for material damages to third persons, for investigation, removal, replacement, acceptance, dismantling or laying bare of all defective goods.

Mayer guarantee is on;

- The crimping of joints using only Mayer NZ certified tooling and devices with the correct depth marked.
- Installation of pipe and fittings are certified Mayer fittings and the installation completed by registered Mayer installers and adherence to Mayer technical rules and guidelines for correct installation principles.

LIMITS OF LIABILITY - MAYER GUANGZHOU CORP - MANUFACTURERS WARRANTY

- Per occurrence maximum NZD\$1,000,000.00
- In aggregate maximum NZD\$1,500,000.00

LIMITS OF LIABILITY - MAYER NZ DISTRIBUTERS AQUATHERM NZ - GENERAL INSURANCE COVER

- Maximum general insurance cover NZD\$10,000,000.00

WARRANTY DATA

Installation address:

Description of installation:

Contractor name: Signature:

Date of completion: Mayer installer number:

This warranty must be fully completed, signed and returned with the completed test sheet within three months of the completion of the project installation to the New Zealand agent.

Mayer NZ
PO Box 99393, Newmarket, Auckland, New Zealand
Ph: 09 570 7204
Email: info@mayerstainless.co.nz



Mayer NZ agents aquatherm NZ Ltd

09 570 7204

36 Rockridge Ave, Penrose,
Auckland 1061, New Zealand

www.mayerstainless.co.nz

Version 3 30/05/19