

CEMINTEL[®]

SURROUND

NEW ZEALAND DESIGN AND INSTALLATION GUIDE



STATE OF CLAD

Distributed exclusively in New Zealand by State of Clad

SURROUND[™] EXTERNAL

External Installation

FCNZ704 July 2023

TABLE OF CONTENTS

01 INTRODUCTION	2	Fire Performance	18
Introduction	2	Extreme Climate Conditions	18
02 PRODUCT OVERVIEW	3	Corrosivity Categories	18
Panel Information	4	Other Design Considerations	18
Product Specifications	4	05 COMPONENTS + ACCESSORIES	19
Colour Palette	5	06 SYSTEM ENGINEERING	23
03 SYSTEM OVERVIEW	6	Design, Detailing and Performance	
Pressure Equalised Ventilated		Responsibilities	24
Cavity System	7	Surround Residential Tables	25
Sealant Filled Joints	8	Surround Commercial Tables	27
Applications	9	NV9 Omega Rail Spacings	28
Benefits of the Cemintel's Surround External		Panel Fixing Requirements	28
Panels on the Fixing System	9	07 INSTALLATION	29
System Solutions	9	Prior to Installation	30
04 DESIGN + AESTHETIC		Installation Set-Out	31
CONSIDERATIONS	10	Installation for Timber and Steel Framing	31
General	11	08 CONSTRUCTION DRAWINGS	
Panel Appearance & Finish	11	+ DETAILS	37
Panel Layout	12	09 SAFETY, HANDLING + GENERAL CARE	50
Structural	13	Health, Safety and PPE	51
Top Hats	14	Handling & General Care	51
Pre-Drilling Panel Holes	14	10 WARRANTY, CLEANING	
Face Fixings	14	+ MAINTENANCE	52
Window & Door Openings	15	Warranty	53
Eaves Junctions	15	Wash Down Process	53
Control Joints	15	Inspection, Repair and Maintenance	53
Moisture Management	15		
Insulation and Energy Efficiency	16		
Solar Reflectance/Absorptance	17		

Introduction

Cemintel's Surround walling system combines a prefinished surface with a simple installation system that can be used for residential and commercial buildings.

This Design and Installation Guide recommends good building practice methodology and has been prepared as a general guide of design considerations, system engineering information and installation procedures for common external applications. It assumes that the user has an intermediate knowledge level of building design and construction. In no way does it replace the services of the building professionals required to design projects, nor is it an

exhaustive guide of all possible scenarios. It is the responsibility of the architect, designer and various engineering parties to ensure that the details in this Design and Installation Guide are appropriate for the intended application.

Surround can be installed either horizontally or vertically, externally or internally. This guide refers to **external installations** only as components differ depending on the installation.

Refer to the 'New Zealand Design and Installation Guide for Cemintel Surround Internal Installation' for instructions regarding internal applications.



022

PRODUCT OVERVIEW

Panel Information

Cemintel Surround panels are prefinished, fibre cement panels that are colour bodied delivering a more natural appearance and depth of colour than can be achieved with a standard surface painted finish. They come trimmed and sealed in a standard 1200 x 3000 x 8mm size*.

Consisting primarily of Portland Cement, wood pulp, reinforcement fibres, air and water, panels have undergone a longer, natural air curing process and offer superior performance in terms of strength, density and durability, making them an excellent choice for commercial applications subject to higher wind loads.

The range comprises 5 colour groups. Each group has a foundation 'Base' colour and 2 complementary textures/patterns featuring a matte finish. There is also a 'Secondary' palette with colours that work across each range. Panels come with a range of colour matched rivets to provide a more seamless aesthetic finish.

Panels feature a UV protective coating applied during the manufacturing process. Rain water washes contaminants away entailing minimal maintenance, ongoing good looks and superior durability.

*Lengths up to 3050mm are available as special orders.

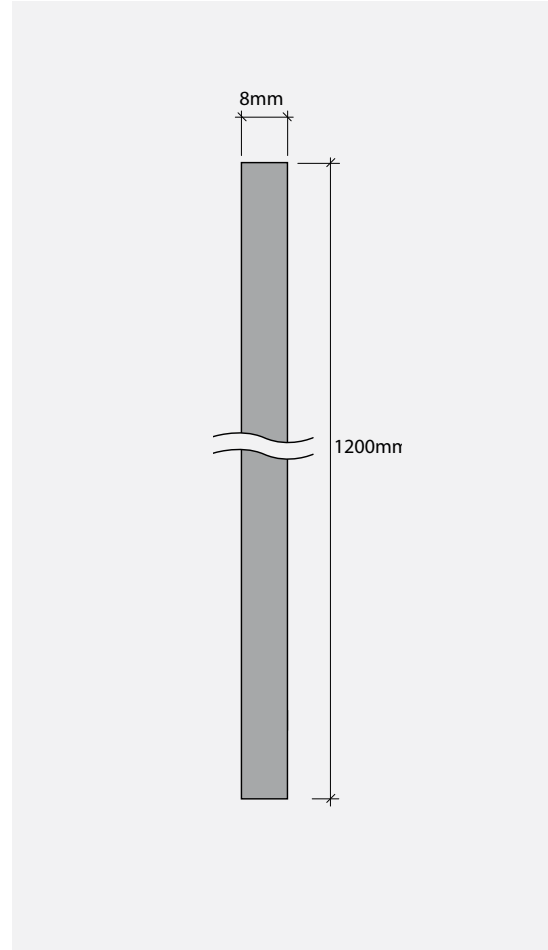

Product Specifications

A technical Data Sheet can be downloaded from stateofclad.co.nz

Dimensional/Geometrical Characteristic	Specification (trimmed panel)	Manufacturing Tolerance	Relevant Standard
Panel Width	1200mm	+ / - 1.5mm	EN 12467
Panel Length	3000mm*	+ / - 1.5mm	EN 12467
Panel Thickness	8mm	+ / - 0.8mm	EN 12467
Panel Mass (EMC)	15.7kg/m ²		



Colour Palette

As Surround is a prefinished product, product images may vary from the actual product in regard to colour and surface finish.

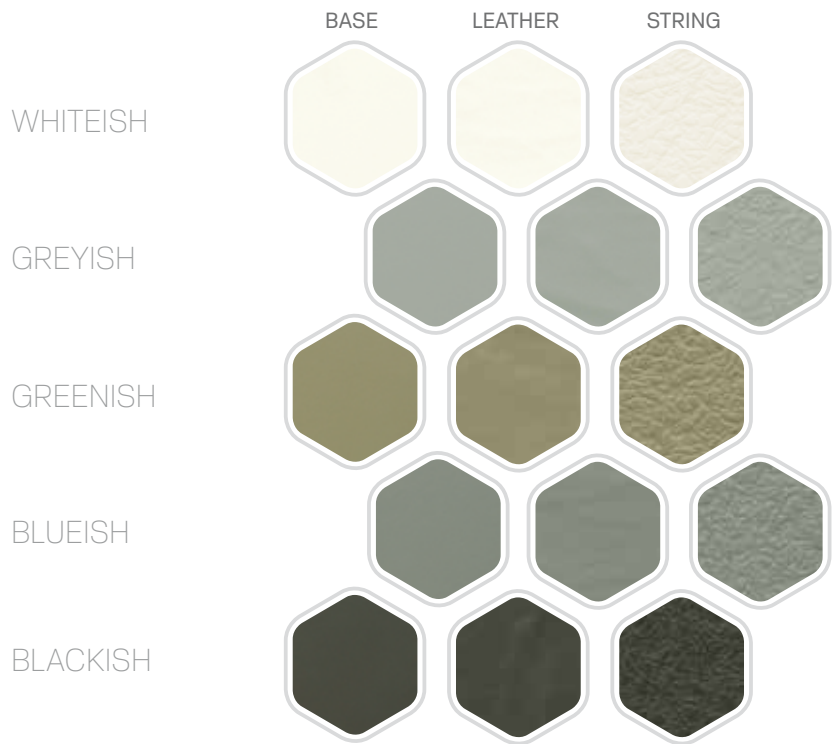

*All Cemintel Surround product is non-stocked and ident only. Minimum order quantities and lead times apply.

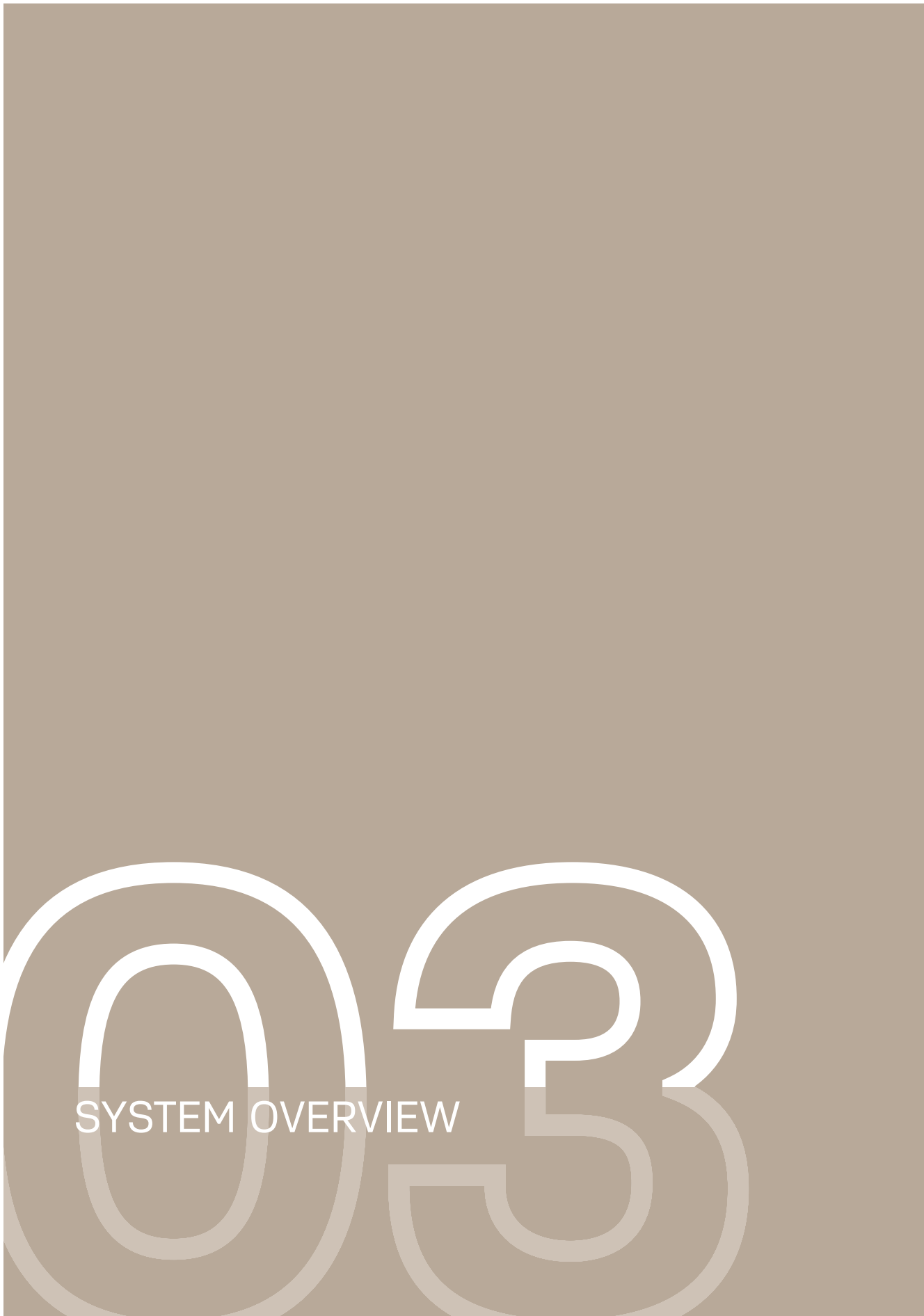

SYSTEM OVERVIEW

SYSTEM OVERVIEW



Cemintel Surround panels are pre-drilled and then fixed onto supporting metal top hats using unique, colour matched, stainless steel rivets.

The Surround system uses only one rivet type which allows a subtle “sliding” movement across the panel. This reduces the complexity of installation and reduces the stresses created where panels are installed with rigid “fixed” points.

Panels are installed to give an express jointed appearance. A vertical gasket tape is placed on the vertical top hat to provide added weather resistance and an angled backing strip is placed at horizontal joints to encourage water run-off.

Pressure Equalised Ventilated Cavity System

Cemintel Surround External panels can be installed horizontally or vertically onto steel or timber stud framing or masonry/concrete using a proven and versatile top hat fixing system. The NV9 Omega system provides a versatile and durable façade which is suitable for an extensive range of building types. Panels are pre-drilled and then fixed with expressed joints to vertical metal top hats using Surround rivets. A vertical gasket tape is placed on the top hat to provide added weather resistance,

and a backing strip is used at horizontal joints to reduce water ingress.

Panels are installed as a pressure equalised ventilated cavity system which is easy to install and delivers a high weather performance system. In certain conditions, eg. higher corrosive zones, there is the option of sealing joints and header to reduce the circulation of air behind the façade.

This manual provides information on both systems.

Cemintel Surround is installed over a rigid air barrier onto top hats using Surround rivets. This creates a pressure equalised cavity system which enhances weather resistance.

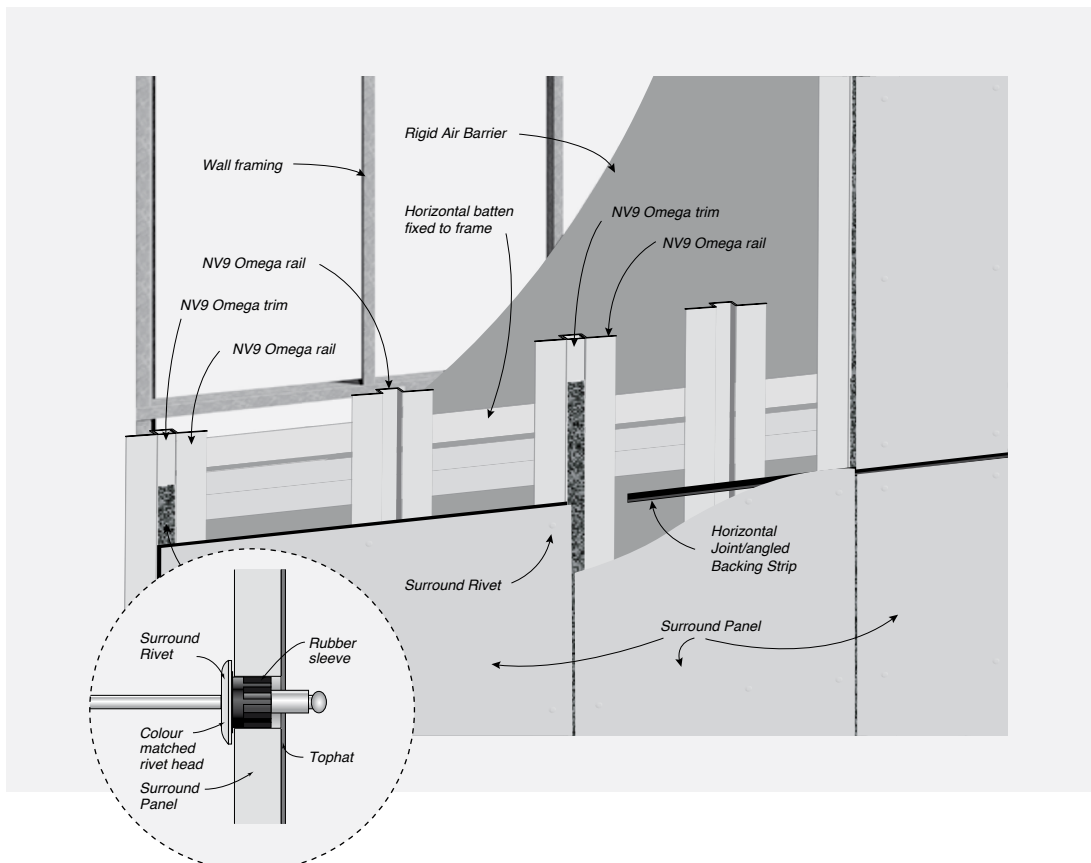

03

SYSTEM OVERVIEW

Typical Surround System Cross Section
for Steel Framing

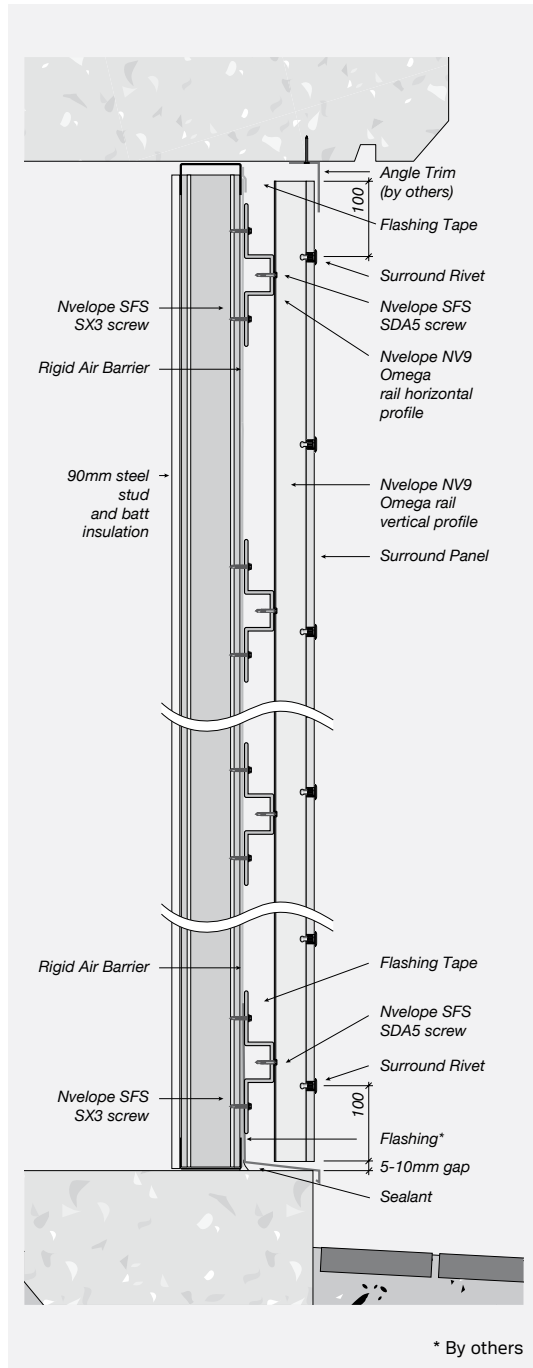

In a pressure equalised system, a cavity is formed between an air barrier and the façade. Openings around the base and top of the façade allow pressure equalisation, and create the drying benefits of air circulation and drainage. This system reduces the risk of moisture penetration and prevents moisture build up, allowing the building shell to dry out, creating a healthier, more breathable building.

Panels are installed to give an express jointed appearance. A vertical gasket tape is placed on the vertical top hat and a metal backing strip is placed at horizontal joints. Horizontal joints at base of wall and at inter-storey junctions are left open to maintain a ventilated cavity and to allow for moisture drainage.

Rigid air barriers are recommended for extra high wind zones or wind loads over 1.5 kPa ULS. All air barriers must be installed as per manufacturers instructions.

Masonry and concrete substrates must be sealed to act as an air barrier for an effective waterproofing system.

Sealant Filled Joints

In some applications, or for aesthetic purposes, it may be preferable to install Surround External panels with joints that are sealant filled. In this case, horizontal backing strips are used and joints are sealed to minimise moisture getting into the cavity. Sealant is also applied to the underside of slabs.

Cemintel Surround panels are to be drilled and then fixed onto supporting metal top hats using screws or Surround rivets.

SYSTEM OVERVIEW



Applications

Cemintel Surround is suitable for all building classes where metal top hats can be fixed to framing however, site environmental factors such as wind and corrosivity zones must be taken into account to determine its suitability for a particular application.

The panels and system have been designed to withstand ultimate wind pressures up to 7.0 kPa including cyclonic conditions.



Benefits of the Cemintel Surround System

- Low maintenance
- No requirement for additional painting costs
- Potential to speed up the construction process
- Large format, lightweight panels are designed to be fixed to top hats which can be fixed to industry standard steel, timber or masonry structural frames
- Cemintel's express jointed fixing system is widely recognised for its high performance
- Top hats have a wider fixing surface for increased installation tolerance, allowing panel movement with changes in wind pressures, thermal movement etc.
- Cemintel's pressure equalised ventilated cavity system allows for higher wind loads, minimises water ingress and allows air flow and drainage
- Suitable for Sea Spray Zones B, C & D
- The unique Surround coloured rivet with pre-assembled rubber sleeve allows slight movement across the panel thereby reducing the stresses created where panels are installed with "fixed" points
- Panels are easy to cut for openings eg. around windows and power boxes
- Durable and weather resistant
 - Provides effective protection against wind, rain and temperature extremes, mould and mildew
 - Panels will not rot, swell or warp when correctly installed and maintained
- Fire – Type A Classification tested in accordance with Appendix C 7.1 of C/AS2. (Table C1.3 of C/AS2)

CodeMark 
CMNZ25002

System Solutions

Weatherproofing	Suitable for a serviceability wind pressure of +2.50 kPa when installed as a pressure equalised system.	AS/NZS 4284
Wind actions (including Cyclonic)	Suitable for ultimate wind loads up to 7.0 kPa with Rigid Air Barrier.	AS/NZS 4284 & AS 4040.3

A technical Data Sheet can be downloaded from stateofclad.co.nz

A large, stylized graphic of the number '04' in a white, outlined font. The '0' is a simple circle, and the '4' is composed of several straight lines. The graphic is positioned in the lower half of the page, with the text 'DESIGN + AESTHETIC CONSIDERATIONS' overlaid on it.

DESIGN + AESTHETIC
CONSIDERATIONS

DESIGN + AESTHETIC CONSIDERATIONS



This section outlines some important areas for consideration in determining whether Cemintel Surround External is suitable for the required application. The following points are not exhaustive. It is the responsibility of the Architect / Building Designer to ensure the design conforms to NZBC requirements and other relevant building standards that may exist for that location. This guide should be read in conjunction with the NZBC.

Panels, top hats and structural framing are required to resist wind loads that are specific to the building site. Additional “local pressure factors” apply to the panels and top hats in accordance with the wind code AS/NZS 1170.2.

Once wind loads have been determined top hat spans, fastener spacings, and sheet fixing details can be selected from the appropriate tables in the ‘System Engineering’ Section of this guide. It is also the responsibility of the Architect/Building Designer to select the appropriate corrosivity category.

Panel Finish

All Surround panels are colour bodied. This works to enhance and give added depth to the surface colour of the panel. It also means that any chips or damage to the panels are less evident.

Base, String and Leather

Surround’s Base, String and Leather finishes have an opaque coating applied to the surface and colour variation between panels is minimal. This allows for mixing and matching from a design perspective.

Note: String and Leather have a three dimensional surface texture. They should be laid in the same direction (ie either horizontal or vertical) rather than in mixed directions.

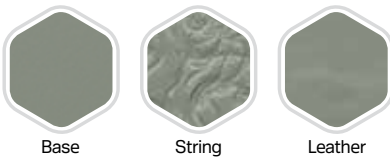

04

DESIGN + AESTHETIC CONSIDERATIONS

FIGURE 4.01 Typical Top Hat set-out - 1200mm Width Vertical Panels with 10mm Joints shown

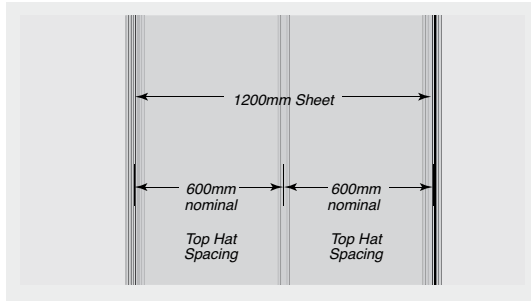

FIGURE 4.03 Vertical Sheeting Aligned Grid Pattern

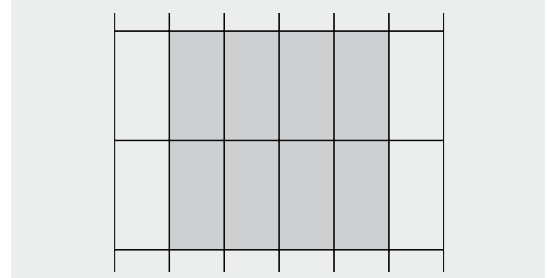

FIGURE 4.02 Horizontal Sheeting Aligned Grid Pattern

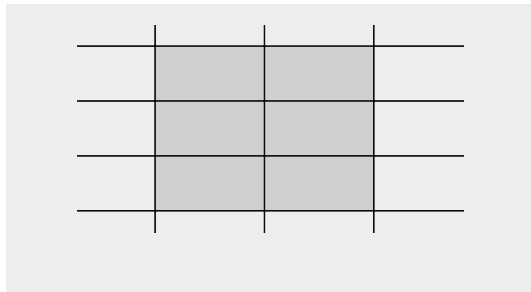
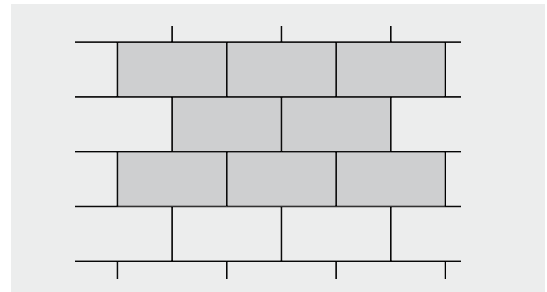

FIGURE 4.04 Horizontal Sheeting Half-bond Pattern



Panel Layout

Panel layout should take into account the following:

- Aesthetic design
- Top hat spacing to allow for expressed joint widths (Refer Fig. 4.01)
- 8-10mm recommended joint width
- Type of structural support
- Size and location of openings
- Building size
- Location of building control joints

Panel layout can be in a grid pattern where vertical and horizontal joints are continuous (Refer Fig. 4.02 & 4.03). In these layouts, construction joints may be positioned behind any vertical or horizontal sheet joint (refer to “Construction Drawings & Details” section).

Panel layout can also be in a vertical or horizontal half-bond pattern where some joints are discontinuous (Refer Fig. 4.04 & 4.05).

This is not an exhaustive list of panel layouts.

DESIGN + AESTHETIC CONSIDERATIONS

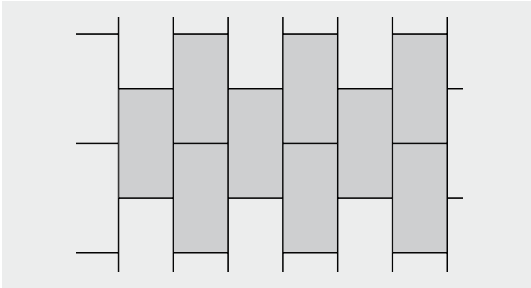
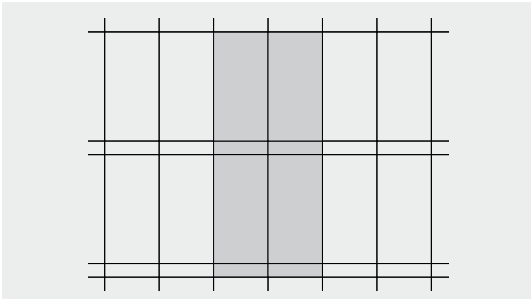
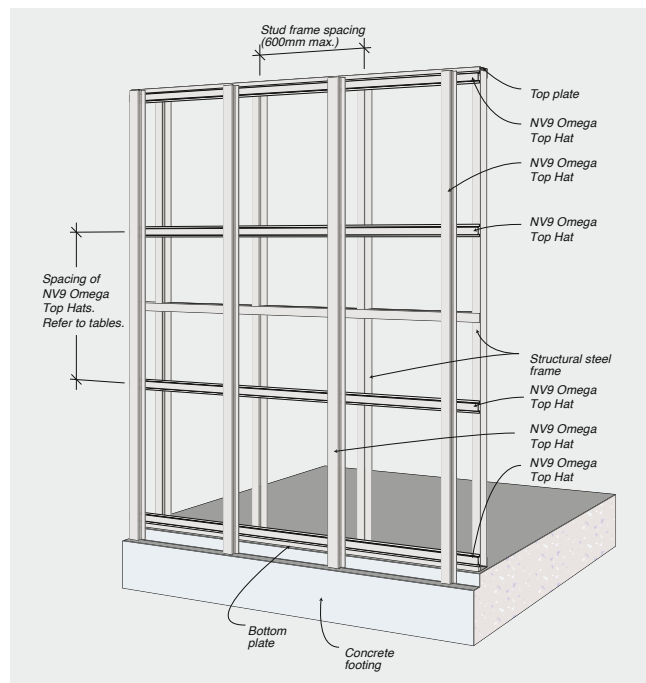
FIGURE 4.06 Vertical Sheeting Half-bond Pattern

FIGURE 4.07 Skirt Panel (Floor to Floor in Excess of 3m)

FIGURE 4.05 Fixing to Timber or Steel Stud Framing

Structural

Framing and Substrate Options

Surround External panels and the framing system can be fixed to either timber or steel framing, as well as to masonry and concrete substrates.

For timber and steel framing, the minimum requirement shall be in accordance with the following standards:

- NZS 3604 – Timber Framed Buildings.
- AS/NZS 4600 – Cold-Formed Steel Structures.
- NZS 3404 – Steel Structures.

Timber Stud or Steel Framing

All vertical top hats must be installed onto horizontal top hats and supported by a primary structural system (ie timber or steel stud framing – Refer Fig. 4.05).

The connection of Top Hats to the structural frame requires engineering design. **It is the responsibility of the project engineer to specify the connection of the top hats to the support structure.**

Masonry or Concrete Walls

Framing can also be fixed over masonry or concrete walls (Refer Fig. 4.08). **All top hat connections must be designed by the project engineer.**

Wind Pressures

Surround External installation has been evaluated for use in all New Zealand wind zones up to and including Extra High in accordance with NZS 3604 for wind pressures up to 7.0 kPa under AS/NZS 1170.2, (including cyclonic zones when fixed to steel framing). In highly corrosive environments, appropriate measures should be taken to protect the frame and metal components from corrosion. Refer to Corrosive Zones table in 'System Engineering' section.

It is critical that the frame is true and plumb. Industry best practice for framed tolerance is 5mm misalignment over 3000mm. Retrofitting Surround External to pre-existing walls must be assessed with the squareness of the substrate.

AS/NZS 1170.0 Table C1 suggests that support framing be designed for a maximum deflection of span/250. Span tables are located in 'System Engineering' section.

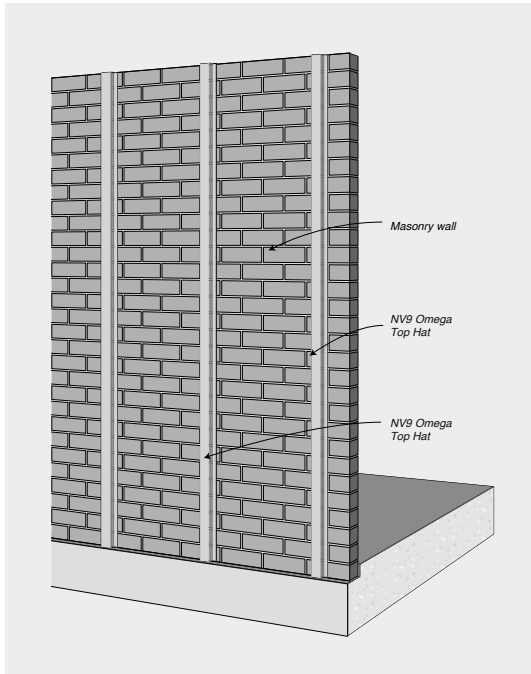
FIGURE 4.08 Fixing to Masonry Wall

The **NZ9 Omega Centre Trim** is used to support the panels at vertical joints. The NZ9 Omega Centre Trim is manufactured from aluminium.

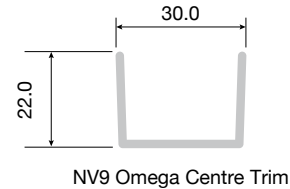

Pre-Drilling Panel Holes

Holes for rivets must be pre-drilled. This activity can be done off-site prior to installation. For **Surround rivets**, a 9.5mm carbide tipped drill bit with centering tip must be used to accommodate the Surround rivet. Do not use hammer action when drilling.

Clean dust out of holes.

Top Hats

The **NV9 Omega top hat** is a purpose designed aluminium section for supporting panels. The unique profile acts to accommodate movement of the sheets at the vertical joints. It is designed to be used in conjunction with NV9 Omega Centre Trim and gasket tape at panel joints. The NV9 Omega top hat is manufactured from 2.4mm aluminium.

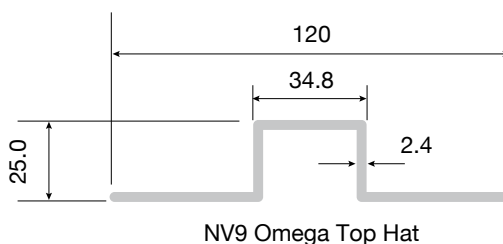

Face Fixings

Panels are fixed to top hats using Surround Rivets. Specific Milwaukee and Gesipa Accubird rivet gun accessories must be used to ensure correct fixing of the Surround Rivet. Rivets are manufactured from stainless steel consisting of V4A stainless steel (equivalent to 316 grade) mandrels and V2A stainless steel (equivalent to 304 grade) sleeves.

Surround rivets are available in colour matching finish.

The Surround rivet, with its unique rubber sleeve, allows a very slight movement across the whole panel thereby reducing the stresses created where panels are installed with "fixed" points. Note: Use of standard rivets and gun heads is NOT ACCEPTABLE.

DESIGN + AESTHETIC CONSIDERATIONS



Window & Door Openings

Cemintel Surround is compatible with industry standard aluminium windows. Aluminium windows **MUST NOT** have sill drain holes that can direct water into the wall cavity.

With the cavity created by the top hat system, particular attention needs to be given to the set out of windows and doors.

The depth of the window needs to be taken into account in the design of the building frame so that the front face of the panel is properly aligned with the window and that the flashing is installed correctly.

When using a rigid air barrier, the thickness of this also needs to be accounted for to achieve a flush finish when determining window set out and reveal depths.

Cemintel recommends installing a sub frame with all windows. Refer to typical window detail drawing in 'Construction Drawings and Details' section of this guide.

Eaves Junction

Air is circulated to the wall cavity. It is not recommended that air be vented into the roof space.

Control Joints

Movement Control Joints

Control joints provided in the panel layout should be aligned with movement control joints provided in the framing.

When undertaking building additions, a movement control joint must be installed at the junction of the existing framing and the new framing. Cladding systems must be discontinuous at this joint (refer to the "Construction Drawings & Details" section).

When setting out panels, design consideration should be given to the location of joints to ensure that minimum panel lengths are observed.

Horizontal Control Joints

A horizontal control joint is required beneath every floor junction to accommodate any expected deflection. The magnitude of the deflection must be verified by the project engineer (refer to the "Construction Details" section).

Vertical Control Joints

Vertical control joints to allow for differential movement are required at the supports of fascia trusses and at the junction of structural elements of different stiffness, such as between concrete

columns and stud frames (refer to the "Construction Drawings & Details" section).

A control joint must also be installed when a masonry wall adjoins framed construction, and at the junction of framed additions or existing buildings, to allow for differential movement. Refer to 'Construction Drawings & Details' section.

Vertical joints in panels must be aligned and extend for the full height of continuous panelling, although additional joints may be placed over openings for ease of installation. As the joints are expressed, consideration to the positioning of joints is important for aesthetic reasons. Placing joints at sides or above openings, or the use of full height windows can reduce the visual impact of joints.

NV9 Omega top hats have been designed to elastically deform when pressure is applied during panel fixing. They are designed to accept a vertical gasket tape which is made from closed cell foam with good weathering and UV resistance. It has a low compression set and low water permeability.

Structural Bracing

Cemintel Surround panels are indirectly attached to the structural framing by way of metal top hats. As a consequence, they are **not** designed to provide wall bracing.

If required, bracing must be provided in the structural framing with methods such as sheet or strap bracing. Where sheet bracing is used, the entire wall framing to be clad with Surround panels must be sheeted to maintain a uniform fixing plane.

Note: window setout will be affected.

Moisture Management

To ensure occupant health, safety and comfort and to protect the building frame from damage, a moisture strategy with the following objectives is required:

- Prevent external moisture entering the building; and
- Prevent the accumulation of internal moisture in a building.

Weatherproofing

Properly designed rigid air barriers including, fibre cement, masonry, concrete and timber may be utilised as an air barrier. The maximum serviceability wind pressure may be governed by the type of air seal/barrier selected.

The Surround system has been tested and assessed to AS/NZS 4284 to withstand water ingress for serviceability wind loads of up to 2.5 kPa for the cavity system using Rigid Air Barriers.



DESIGN + AESTHETIC CONSIDERATIONS

Windows must be a front draining style and have appropriate flashing to prevent moisture ingress and penetrations should be effectively sealed at the air barrier and at the cladding.

Condensation

Condensation occurs as air cools and contacts cold surfaces that are below the air's dew point. Absorptive materials such as brick, cement sheet and timber are permeable and act as a buffering material until they become saturated, whilst non-absorptive materials such as steel and glass reach saturation quickly. Water can then accumulate and must be allowed to dry or drain away. Moist surfaces can result in health issues for occupants and lead to degradation of building materials and loss of structural integrity.

The likelihood and severity of condensation is largely a function of:

- Climate (primarily temperature and humidity including seasonal and diurnal variations)
- Occupancy and building use
- Material properties of the building envelope (including insulation material type and R-Value)
- Passive and mechanical ventilation
- Air tightness
- The building envelope's ability to allow or prevent the movement of vapour.
- The building envelope's ability to act as a water barrier behind the primary cladding element.

State of Clad recommends that architects/designers undertake a condensation risk analysis prior to selecting vapour control membranes. A rigid air barrier may be required where buildings are subject to higher wind loads, and in some climate zones may require the incorporation of a vapour barrier membrane in addition to the rigid air barrier. Greater use of insulation, better sealing to restrict air movement, and increased use of air conditioning leads to larger differences between the temperature and water vapour content of indoor environments and adjacent outdoor areas and greatly increases the risk of condensation at surfaces and interstitial spaces.

Rigid Air Barriers

All buildings require an air barrier to be installed. This may be fibre cement, ply wood or masonry. Installation for Cemintel fibre cement Rigid Air Barrier is detailed in the Cemintel Rigid Air Barrier Design and Installation Guide. Masonry substrates must be sealed to act as an air barrier for an effective waterproofing system. Wind forces can produce lower air pressures within buildings than on the outside, assisting to force water through gaps in the building envelope such as around penetrations and joints, even at low wind speeds.

The system incorporates a drained cavity, similar to brick veneer construction. This is highly effective at removing condensation and any incidental moisture from the cavity, thereby ensuring that the components within the cavity can dry out. The wall wrap or rigid air barrier must be installed in accordance with manufacturers instructions.

Condensation is a complex problem, and can occur under a variety of conditions, not just cold weather. Literature on this subject is available from BRANZ/MBIE and should be consulted when building in areas where condensation is likely to occur.

Insulation and Energy Efficiency

Thermal insulation values for walls must be calculated in order to meet the energy efficiency requirements of NZBC Clause H1.

Calculation tools are available (BRANZ) based on the methods of NZS 4218 for the total insulation values for walls, based on the climate zone (as shown in Appendix B of NZS 4218) and the construction R-values of the building wall elements.

Construction R-values should be calculated in accordance with NZS 4214 Methods of determining the total thermal resistance of parts of buildings.

Further information can be found in Acceptable Solution H1/AS1 and the BRANZ House Insulation Guide.

DESIGN + AESTHETIC CONSIDERATIONS

**Solar Reflectance/Absorptance**

Cemintel Surround has been tested to ASTM E 903-96 'Standard Test Method for Solar Absorptance, Reflectance and Transmittance of Materials Using Integrating Spheres'. Values are included in the table below.

Description	Solar Reflectance %	Solar Absorbtion %	Basix Colour	Relevant Standard
Whiteish Base	67.9	32.1 (+/-2.0)	Light	ASTM E903.12
Whiteish Leather	67.9	32.1 (+/-2.0)	Light	ASTM E903.12
Whiteish String	67.9	32.1 (+/-2.0)	Light	ASTM E903.12
Blackish Base	16.1	83.9 (+/-0.5)	Dark	ASTM E903.12
Blackish Leather	16.1	83.9 (+/-0.5)	Dark	ASTM E903.12
Blackish String	16.1	83.9 (+/-0.5)	Dark	ASTM E903.12
Greyish Base	31.9	64.1 (+/-1.1)	Medium	ASTM E903.12
Greyish Leather	31.9	64.1 (+/-1.1)	Medium	ASTM E903.12
Greyish String	31.9	64.1 (+/-1.1)	Medium	ASTM E903.12
Blueish Base	21.5	78.5 (+/-0.6)	Dark	ASTM E903.12
Blueish Leather	21.5	78.5 (+/-0.6)	Dark	ASTM E903.12
Blueish String	21.5	78.5 (+/-0.6)	Dark	ASTM E903.12
Greenish Base	19.6	80.4 (+/-0.6)	Dark	ASTM E903.12
Greenish Leather	19.6	80.4 (+/-0.6)	Dark	ASTM E903.12
Greenish String	19.6	80.4 (+/-0.6)	Dark	ASTM E903.12
Secondary Palette				
Whiteout	72.1	27.9 (+/-2.2)	Light	ASTM E903.12
Aero	33.0	67.0 (+/-1.0)	Medium	ASTM E903.12
Husk	41.5	58.5 (+/-1.2)	Medium	ASTM E903.12
Blackout	6.6	93.4 (+/-0.6)	Dark	ASTM E903.12
Strike	49.3	50.7 (+/-1.5)	Medium	ASTM E903.12
Volta	45.6	54.4 (+/-1.4)	Medium	ASTM E903.12
Mainland	38.4	61.6 (+/-1.2)	Medium	ASTM E903.12
Quinta	42.0	58.0 (+/-1.3)	Medium	ASTM E903.12
Mete	46.8	53.2 (+/-1.4)	Medium	ASTM E903.12
Hover	7.8	92.2 (+/-0.6)	Dark	ASTM E903.12
Maya	52.3	47.7 (+/-1.6)	Medium	ASTM E903.12
Gauze	24.3	75.7 (+/-0.7)	Dark	ASTM E903.12
Garb	11.2	88.8 (+/-0.6)	Dark	ASTM E903.12
Greenback	33.7	66.3 (+/-1.0)	Medium	ASTM E903.12
Tuss Grey	10.7	89.3 (+/-0.6)	Dark	ASTM E903.12
Woodlot	11.2	88.8 (+/-0.6)	Dark	ASTM E903.12



DESIGN + AESTHETIC CONSIDERATIONS

Fire Performance

Cemintel Barestone is not a fire rated system on its own, but can be used as part of a fire rated system. The cladding has been tested to ISO 5660 and meets the requirements of a Type A cladding as per table 5.1 of C/AS1 and table 5.5 of C/AS2.

Fire Rated Wall Construction

Cemintel Surround External can be used as part of a system to achieve a fire rated wall construction.

Extreme Climate Conditions

Corrosive Zones

Consideration of corrosivity zones should be taken into account. While Surround panels are not susceptible to corrosion, consideration needs to be made regarding the impact of climate conditions on system components such as fasteners, clips and metal framing, for example.

Corrosivity zones are described in NZS 3604, with further information available in AS/NZS 2728 and E2/AS1. It is recommended that the building designer assess the site in accordance with the standards and local conditions to determine suitability of the system.

The Surround system may be used in zones B, C and D except

for fixing to masonry which is limited to zones B & C. The System is not suitable for use in Zone E or in industrial and geothermal areas where the environment may be acidic with a pH of less than 5.

In all zones, all walls which are protected by soffits above must be washed down twice per year, to remove salt and debris buildup, particularly around window/door openings.

Temperature Extremes

Surround External is not warranted for use in freezing conditions where the Surround panel is in contact with snow drifts or extremely hot conditions (that is above 60°C).

Other Design Considerations

Services

The Cemintel Surround external system will accommodate services that are run through the framing. Any notches or holes formed must be considered in the framing design.

Renovations

When undertaking building renovations, remove all cladding, wall wrap and insulation from the original wall framing. Ensure the condition of the framing is in accordance with current requirements and is as true and as plumb as possible (within accepted industry tolerances of 5mm misalignment over 3000mm).

Install additional framing, insulation, air barrier and flashing as required.

Limitations

Cemintel Surround is not warranted for the following applications:

- Panels with non-vertical face (e.g. parapet capping)
- Wet areas such as bathrooms
- Chimney cladding
- Exposure to surface temperatures greater than 60°C
- Non vented parapet cladding
- Contact with standing snow or ice
- Fixing of tiles or other materials to the face of the panels as the face is prefinished.

The above listing is not intended to be comprehensive. If in doubt, please contact State of Clad.



COMPONENTS + ACCESSORIES

05

COMPONENTS + ACCESSORIES

Note: Codes can change from time to time. Refer to the website for the current list of components prior to ordering.

Cemintel Surround Panels and Colour Matched Accessories

Description	Panel Code	Colour Matched Rivet
BLUEISH Base	474567	474592
BLUEISH Leather	474569	474592
BLUEISH String	474568	474592
BLACKISH Base	474552	474589
BLACKISH Leather	474554	474589
BLACKISH String	474553	474589
GREENISH Base	474562	474591
GREENISH Leather	474564	474591
GREENISH String	474563	474591
GREYISH Base	474557	474590
GREYISH Leather	474559	474590
GREYISH String	474558	474590
WHITEISH Base	474547	474588
WHITEISH Leather	474549	474588
WHITEISH String	474548	474588
SECONDARY PALETTE		
WHITEOUT	474575	474596
AERO	474587	474608
HUSK	474572	474593
BLACKOUT	474581	474602
STRIKE	474584	474605
VOLTA	474579	474600
MAINLAND	474580	474601
QUINTA	474582	474603
METE	474578	474599
HOVER	474583	474604
MAYA	474573	474594
GAUZE	474576	474597
GARB	474585	474606
GREENBACK	474574	474595
TRUSS GREY	474577	474598
WOODLOT	474586	474607







*Lengths up to 3050mm are available as special orders.

COMPONENTS + ACCESSORIES

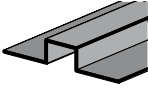
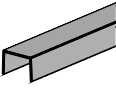
05

Note: Codes can change from time to time. Refer to the website for the current list of components prior to ordering.



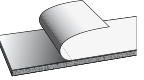
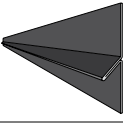
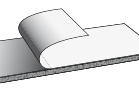











Accessories

Accessories	Description	Size / Colour	Quantity	Product Code
TOP HATS				
	The NV9 Omega top hat is a purpose designed aluminium section for supporting panels. The unique profile acts to accommodate movement of the sheets at the vertical joints. It is designed to be used in conjunction with NV9 Omega Centre Trim and gasket tape at panel joints. The NV9 Omega top hat is manufactured from 2.4mm aluminium.	3000mm	1 each	475354
	The NZ9 Omega Centre Trim is used to support the panels at vertical joints The NZ9 Omega Centre Trim is manufactured from aluminium.	3000mm	1 each	475355
FASTENERS				
	Surround Rivet – for fixing Surround panels to Top Hat framing. Each rivet comes with an already assembled EPDM (TPS-SEBS) gasket. Rivet heads are colour matched to the panel. Rivets are manufactured from stainless steel consisting of V4A (equivalent to 316 grade) stainless steel mandrels and V2A (equivalent to 304 grade) stainless steel sleeves. Note: Use only the Cemintel Rivet and Rivet Gun Head. Standard rivets and gun heads are NOT ACCEPTABLE.	Colour matched to Cemintel Surround panels 4x18mm	100 per pack	See list of codes on page 20
	NV9 SDA5 Screws - For fixing NZ9 Omega Rails to each other. 5.5x19mm A4 (316) Stainless Steel hex head self drilling screw.		500 per pack	475362
	NV9 SX3 Timber Screws - For fixing NZ9 Omega Rails to timber framing. 6.5x60mm A4 (316) Stainless Steel hex head self drilling screw.		100 per pack	475358
	NV9 SX3 Steel Screws - For fixing NZ9 Omega Rails to steel framing. 6x48mm A4 (316) Stainless Steel hex head self drilling screw.		500 per pack	475359
	NV9 SX3 Masonry Screws - For fixing NZ9 Omega Rails to masonry structure. 10x85mm A4 (316) Stainless Steel hex head screw.		25 per pack	475360
	NV9 SX3 Brick/Block Screws - For fixing NZ9 Omega Rails to Brick or Block structure. 10x80mm A4 (316) Stainless Steel hex head screw.		25 per pack	475361
Accessories	Description	Size / Colour	Quantity	Product Code
GASKETS				
	NV9 Single Sided EPDM Tape - self-adhesive tape is made from EPDM closed cell foam which has high UV resistance. The gasket has adhesive on one side (with a release paper) and is adhered to the NV9 Omega Centre Trim to prevent moisture entry at vertical joints.	1.6mm x 24mm x 25m Black	1 each	475357
BACKING STRIPS				
	NV9 Joint Backing Strip – a rolled aluminium section designed to deflect water and create an attractive expressed joint appearance at horizontal joints. Suitable only where a non-sealed façade system is appropriate.	3040mm	1 each	475363
	NV9 Express Backing Strip - may be used in lieu of NV9 Joint Backing Strip for sealant filled system option.	6.5mm x 60mm x 3000mm	1 each	481749

05

COMPONENTS + ACCESSORIES

Note: Codes can change from time to time. Refer to the website for the current list of components prior to ordering.

	ExpressWall Backing Strip – may be used in lieu of Surround Angled Backing Strip for sealant filled system option.	1194mm 2394mm 2994mm	1 each 1 each 1 each	474521 474520 474499
	Bond Breaker Tape – Required where horizontal joints are sealed.			Supplied by others
OTHER				
	NV9 Internal Corner Closer – Aluminium angle flashing used at internal corners. Manufactured from aluminium and powder coated to one side.	3000mm	1 each	475356
	NV9 External Corner Closer – Aluminium angle flashing used at external corners. Manufactured from aluminium and powder coated to one side.	3000mm	1 each	481747
	Adhesive – for fixing spacer at head junction. Sikaflex 11FC Grey For use as a backing strip adhesive when installing ExpressWall Backing strips			Supplied by others
	Sealant – is used to seal joints for control joints, junctions etc. Sikaflex Sealant PRO-2HP Grey			Supplied by others
	Backing Rod – for sealant backing – used to enable correct filling of joints with sealant. Also used as an air seal at window openings and construction junctions. The diameter of backing rod must be appropriate for the width of the gap being filled.			Supplied by others
	Cemintel Edge Sealer – for sealing panel edges after on-site cutting.	200ml	1 each	186529
TOOLS – When using Surround Rivets the following tools must be used				
	Surround Drill Bit Ø 9.5mm – for drilling accurate holes in the Surround panel to accept the Surround rivet. Fits standard 10mm drill chuck.		1 each	474527
	Surround Drill Bit Ø 4.1mm – for use with Rivet Centralising Tool to drill accurate rivet holes into the Top Hats		5 per pack	474529
	Surround Rivet Centralising Tool – for drilling accurate rivet holes in the top hats. Fits a 10mm drill chuck to ensure that the 4.1mm rivet hole is perfectly centred in the pre-drilled panel.		1 each	474528
	Surround Rivet Gun Nose Piece – required to achieve the correct rivet fixing and offset. Attaches to the Milwaukee and Gesipa Accubird battery operated, blind rivet gun and ensures the correct spacing of the rivet head from the panel face. Also designed to seat the larger rivet head correctly and prevent damage to the coloured rivet head. Note: Standard rivet gun nose piece is NOT ACCEPTABLE		1 each	474530
Other Tools				
Product	Description	Size	Quantity	Product Code
	Surround Blind Rivet Gun – Cemintel recommends the use of the Milwaukee and GESIPA® Accubird Battery Operated Blind Rivet Gun			Supplied by others
	Makita Plunge Saw Kit (1300W) includes 1400mm guide rail and bonus 165mm fibre cement saw blade – excellent for cutting cement based sheets. Must be used with a dust extraction system.	165mm	1	Supplied by others
	Makita 165mm Fibre Cement Saw Blade – ideal for use with the Makita Plunge saw and other 165mm circular saws fitted with vacuum extraction systems	165mmx20x4T	1	Supplied by others
	Dust Extraction		1	Supplied by others
	Grinder Tool		1	Supplied by others

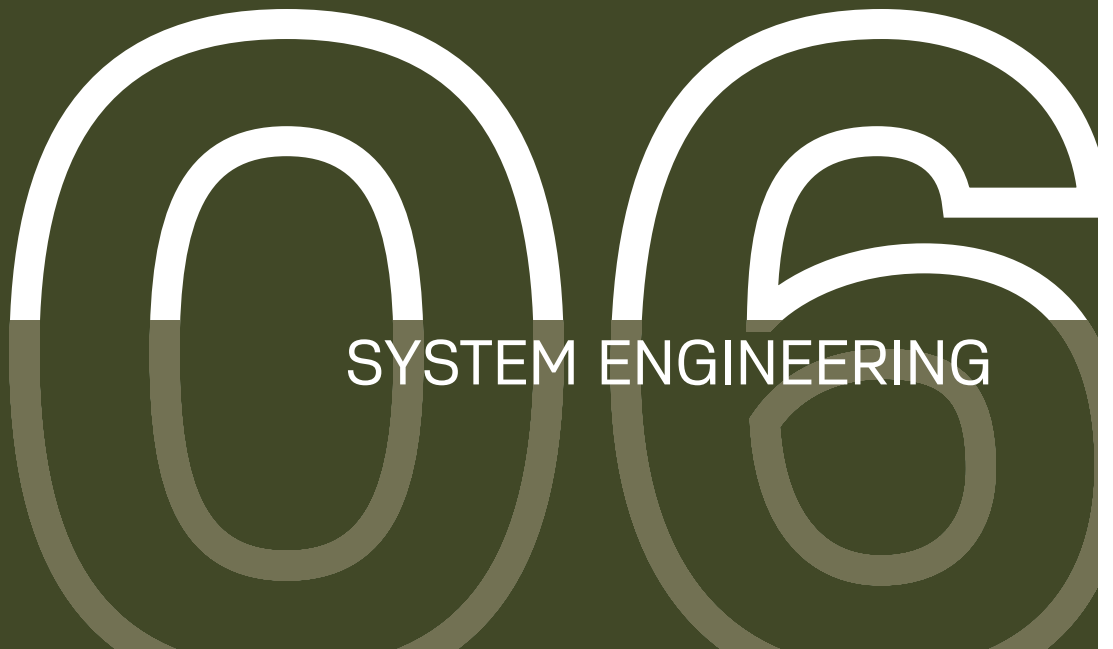

SYSTEM ENGINEERING



SYSTEM ENGINEERING

Design, Detailing And Performance Responsibilities

Cemintel Surround System

Cemintel have engaged independent testing laboratories to test and report on the performance of a wall in accordance with the relevant New Zealand Standards. Consultants with relevant experience will use these test reports to provide opinions and assessments that extend the tested arrangement to include various on-site installation configurations and details that meet appropriate criteria performance.

Project Consultants (Structural, Fire, Acoustic, Etc.)

These consultants are typically responsible for the following:

- Opinions on expected laboratory performance of wall configurations that vary from actual test configuration, such as substitution products and components.
- Judgements about expected field performance using laboratory test reports and practical experience.
- Design, specification and certification of structural, fire, acoustic, durability, weather tightness and any other required performance criteria for individual projects.

This involves the design and selection of building elements, such as wall and floors and their integration into the building considering the following:

- Interface of different building elements and to the structure / substrate.
- Wall and floor junctions.
- Penetrations.
- Flashing issues.
- Room / building geometry.
- Acoustic and water penetration field-testing.

Design Responsibility

Panels, top hats and structural framing are required to resist wind loads that are specific to the building site. Additional 'local pressure factors' can apply to the panels and top hats in accordance with the wind code AS/NZS 1170.2. It is recommended that the Architect/Building Designer assigns the responsibility for the facade design to the Project Engineer. Once wind loads have been determined, top hat spans, fastener spacings, and sheet fixing details may be selected from the appropriate tables in this manual. It is also the responsibility of the Architect/Building Designer to select the appropriate corrosivity category. Refer to appropriate details in this guide.

The performance levels of walls documented in this guide are either what is reported in a test or the documented opinion of consultants. Performance in projects is typically the responsibility of:

Project Certifier and/or Builder

These professionals are typically responsible for:

- Identifying the performance requirements for the project in accordance with the NZBC and clearly communicating this to the relevant parties.
- Applicability of any performance characteristics supplied by Cemintel including test and opinions for the project.
- The project consultants' responsibilities detailed above if one is not engaged in the project.

Cemintel and State of Clad do not provide consulting services. Cemintel and State of Clad only provides information that has been prepared by others and therefore shall not be considered experts in the field.

Any party using the information contained in this guide or supplied by Cemintel and State of Clad in the course of a project must satisfy themselves that it is true, current and appropriate for the application, consequently accepting responsibility for its use.

It is the responsibility of the Architect/Building Designer and engineering parties to ensure that the details in this design guide are appropriate for the intended application.

The recommendations in this guide are formulated along the lines of good building practice, but are not intended to be an exhaustive statement of all relevant data.

Cemintel is not responsible for the performance of constructed walls, including field performance, and does not interpret or make judgements about performance requirements in the NZBC in a specific project application.

Note: it is the responsibility of the Project Engineer to specify the connection of the top hats to the support structure. It is also the responsibility of the Project Engineer to calculate the wind loads for the cladding of a project.

Stud Wall support framing

NV9 Omega rails can be fixed to vertical structurally designed timber SG8 or higher grade, or steel support framing of minimum 0.5mm BMT for residential projects within the scope of NZS 3604 and 1.2mm BMT for projects outside of NZS 3604.

SYSTEM ENGINEERING



Surround Residential Tables - General Zones (areas greater than 1200mm from building corner)

TABLE 6.01

Wind Class (NZS 3604)	Stud spacing (mm)	Cladding Fixing Spacing (mm)	Spacing of vertical Top hat (mm)			
			300	400	450	600
			Spacing of horizontal top hat (mm)			
Low	300	600	1900	1700	1650	1500
	400	600	1900	1700	1650	1500
	450	600	1900	1700	1650	1500
	600	600	1900	1700	1650	1500
Medium	300	600	1700	1550	1500	1350
	400	600	1700	1550	1500	1350
	450	600	1700	1550	1500	1350
	600	600	1700	1550	1500	1350
High	300	600	1500	1350	1300	1200
	400	600	1500	1350	1300	1200
	450	600	1500	1350	1300	1200
	600	600	1500	1350	1300	1200
Very High	300	550	1400	1250	1200	1100
	400	550	1400	1250	1200	1100
	450	550	1400	1250	1200	1100
	600	550	1400	1250	1200	1100
Extra High	300	450	1300	1200	1150	1000
	400	450	1300	1200	1150	1000
	450	450	1300	1200	1150	1000
	600	450	1300	1200	1150	1000

Notes:

- Steel Stud framing is assumed to be grade G550 for 0.5 BMT and 0.75 BMT steel or grade G2 for 1.2 BMT steel. All stud framing shall be designed in accordance with AS/NZS 4600:2018.
- Timber Stud framing is assumed to be SG8 timber conforming with NZS 3622:2004 with a J5 joint group assuming dry timber in accordance with NZS 3603:1993.
- Fixing between horizontal top hat and stud to be 2/NV9 SX3 Steel Screws or 2/NV9 SX3 Timber Screws. Where fixing to other substrates, two fixings shall be provided at the stud spacing with a pull out/over ultimate capacity of ≥ 1.14 kN per single fixing.
- Fixing between horizontal and vertical top hats to be 1/NV9 SDA5 Screw per intersection of members where the second layer is inverted or 2/NV9 SDA5 Screws otherwise.
- Fixing between vertical top hat and cladding to be a single Surround Rivet fastener. Panels fixed to three vertical top hats.
- Maximum cantilever is 0.2 x adjacent span



SYSTEM ENGINEERING

Surround Residential Tables - Corner Zones (areas less than 1200mm from building corner)

TABLE 6.02

Wind Class (NZS 3604)	Stud spacing (mm)	Cladding Fixing Spacing (mm)	Spacing of vertical Top hat (mm)			
			300	400	450	600
			Spacing of horizontal top hat (mm)			
Low	300	600	1500	1400	1350	1200
	400	600	1500	1400	1350	1200
	450	600	1500	1400	1350	1200
	600	600	1500	1400	1350	1200
Medium	300	500	1400	1250	1200	1100
	400	500	1400	1250	1200	1100
	450	500	1400	1250	1200	1100
	600	500	1400	1250	1200	1100
High	300	350	1250	1100	1050	800
	400	350	1250	1100	1050	800
	450	350	1250	1100	1050	800
	600	350	1250	1100	1050	800
Very High	300	250	1100	950	850	650
	400	250	1100	950	850	650
	450	250	1100	950	850	650
	600	250	1100	950	850	650
Extra High	300	200	1050	800	700	500
	400	200	1050	800	700	500
	450	200	1050	800	700	500
	600	200	1050	800	700	500

Notes:

- Steel Stud framing is assumed to be grade G550 for 0.5 BMT and 0.75 BMT steel or grade G2 for 1.2 BMT steel. All stud framing shall be designed in accordance with AS/NZS 4600:2018.
- Timber Stud framing is assumed to be SG8 timber conforming with NZS 3622:2004 with a J5 joint group assuming dry timber in accordance with NZS 3603:1993.
- Fixing between horizontal top hat and stud to be 2/NV9 SX3 Steel Screws or 2/NV9 SX3 Timber Screws. Where fixing to other substrates, two fixings shall be provided at the stud spacing with a pull out/over ultimate capacity of ≥ 1.14 kN per single fixing.
- Fixing between horizontal and vertical top hats to be 1/NV9 SDA5 Screw per intersection of members where the second layer is inverted or 2/NV9 SDA5 Screws otherwise.
- Fixing between vertical top hat and cladding to be a single Surround Rivet fastener. Panels fixed to three vertical top hats.
- Maximum cantilever is 0.2 x adjacent span

SYSTEM ENGINEERING



Surround Commercial Tables

TABLE 6.03

Ultimate wind load (kPa)	Stud spacing (mm)	Cladding Fixing Spacing (mm)	Spacing of vertical Top hat (mm)			
			300	400	450	600
			Spacing of horizontal top hat (mm)			
1.00	300	550	1400	1300	1250	1100
	400	550	1400	1300	1250	1100
	450	550	1400	1300	1250	1100
	600	550	1400	1300	1250	1100
1.25	300	450	1300	1200	1150	1000
	400	450	1300	1200	1150	1000
	450	450	1300	1200	1150	1000
	600	450	1300	1200	1150	1000
1.50	300	350	1250	1100	1050	800
	400	350	1250	1100	1050	800
	450	350	1250	1100	1050	800
	600	350	1250	1100	1050	800
1.75	300	300	1150	1050	950	700
	400	300	1150	1050	950	700
	450	300	1150	1050	950	700
	600	300	1150	1050	950	700
2.00	300	250	1100	950	800	600
	400	250	1100	950	800	600
	450	250	1100	950	800	600
	600	250	1100	950	800	600
2.25	300	225	1050	800	750	550
	400	225	1050	800	750	550
	450	225	1050	800	750	550
	600	225	1050	800	750	550
2.50	300	200	1000	750	650	500
	400	200	1000	750	650	500
	450	200	1000	750	650	500
	600	200	1000	750	650	500
2.75	300	200	900	650	600	Not Suitable
	400	200	900	650	600	Not Suitable
	450	200	900	650	600	Not Suitable
	600	200	900	650	600	Not Suitable
3.00	300	200	800	600	550	Not Suitable
	400	200	800	600	550	Not Suitable
	450	200	800	600	550	Not Suitable
	600	200	800	600	550	Not Suitable
3.50	300	200	700	500	Not Suitable	Not Suitable
	400	200	700	500	Not Suitable	Not Suitable
	450	200	700	500	Not Suitable	Not Suitable
	600	200	700	500	Not Suitable	Not Suitable
4.00	300	2100	600	450	Not Suitable	Not Suitable
	400	2100	600	450	Not Suitable	Not Suitable
	450	2100	600	450	Not Suitable	Not Suitable
	600	2100	600	450	Not Suitable	Not Suitable
5.00	300	150	500	350	Not Suitable	Not Suitable
	400	150	500	350	Not Suitable	Not Suitable
	450	150	500	350	Not Suitable	Not Suitable
	600	150	500	350	Not Suitable	Not Suitable
6.00	300	100	400	300	Not Suitable	Not Suitable
	400	100	400	300	Not Suitable	Not Suitable
	450	100	400	300	Not Suitable	Not Suitable
	600	100	400	300	Not Suitable	Not Suitable

Notes:

- Steel Stud framing is assumed to be grade G2 for 1.2 BMT steel. All stud framing shall be designed in accordance with AS/NZS 4600:2018.
- Timber Stud framing is assumed to be SG8 timber conforming with NZS 3622:2004 with a J5 joint group assuming dry timber in accordance with NZS 3603:1993.
- Fixing between horizontal top hat and stud to be 2/NV9 SX3 Steel Screws or 2/NV9 SX3 Timber Screws. Where fixing to other substrates, two fixings shall be provided at the stud spacing with a pull out/over ultimate capacity of ≥ 1.14 kN per single fixing.
- Fixing between horizontal and vertical top hats to be 1/NV9 SDA5 Screw per intersection of members where the second layer is inverted or 2/NV9 SDA5 Screws otherwise.
- Fixing between vertical top hat and cladding to be a single Surround Rivet fastener. Panels fixed to three vertical top hats.
- Maximum cantilever is 0.2 x adjacent span



SYSTEM ENGINEERING

NV9 Omega Rail Spacings

The design capacities of the Cemintel Surround façade system are in limit state format and intended for use with AS/NZS 1170.2.

To obtain equivalent permissible load capacity, divide the “ultimate wind capacity” in Table 6.03 by 1.5.

The deflection of the top hats as detailed in these tables is no more than $\text{span}/250$ when subjected to serviceability wind load of 68% of ultimate wind loads.

FIGURE 6.01 Double Top Hat Span Installation

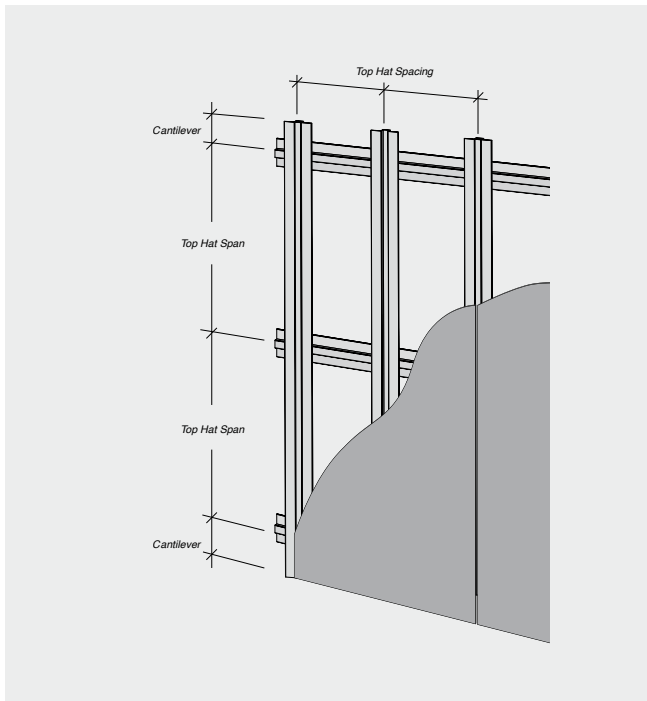

Panel Fixing Requirements

FIGURE 6.02 Vertical Sheet Fixing

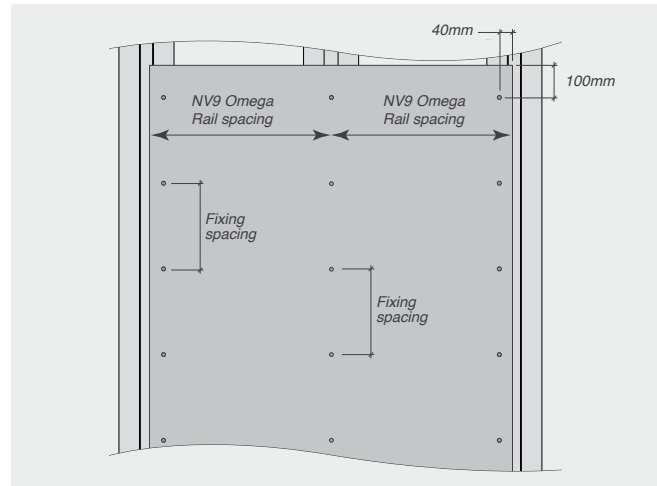

07

INSTALLATION

07

INSTALLATION

CHECKLIST – Prior to Installation

The following pre-install checklist may assist to ensure you have the best possible outcome when using Surround External.

- Ensure substrate is straight and plumb. Pack studs to straighten if necessary (timber frames as per NZS 3604, steel frames as per AS/NZS 4600). Industry best practice for frame tolerance is 5mm misalignment over 3000mm.
- Ensure studs are correctly located and of the appropriate thickness.
- Confirm bracing is in place. Where sheet bracing is used behind panels, the entire wall area needs to be braced or bracing sheet packers fixed to the frame to ensure a uniform fixing plane.
- Remove any concrete that may foul the cladding line, particularly at steps in slabs and isolated columns.
- Ensure there is adequate ground clearance to the bottom edge of the Surround panels as per regulatory requirements (including for water/rain runoff and termite management). These can vary from 100-175mm depending on type of ground.
- Confirm your panel layout to determine the location of joints and identify where additional studs are required.
- Flashings, membranes and air barrier should be correctly installed, overlapped and taped at joints, prior to fixing panels.
- Install windows so that the back of the front face of the window (or any other protrusions including doors or meter boxes) will be flush with the face of the panels.
- Fit Head flashings over windows, doors and other penetrations.
- Confirm the chosen eaves/soffit details and prepare accordingly.
- Consider the need for structural support for fixtures such as pergolas and balconies. No loads may be carried by the cladding.
- Confirm membranes and flashings for balcony areas have been installed in accordance with manufacturers' specifications.
- Arrange for a pre-cladding inspection by the appropriate local building consent authority if required.



Check quality and quantity of panels and components before installing. If there is any sign of damage or visible defects in panels, or the colour/finish is not in keeping with the owner's aesthetic requirements DO NOT INSTALL. Contact State of Clad to address any issues.



Installation Set-Out

Appropriate panel fixing layout and top hat spacing should be suitable for the project design wind pressure. It is recommended that fasteners be fixed 100mm from the top and bottom edges of the panel and 40mm in from the side of the panels.

FIGURE 7.01 Horizontal Sheet Fixing

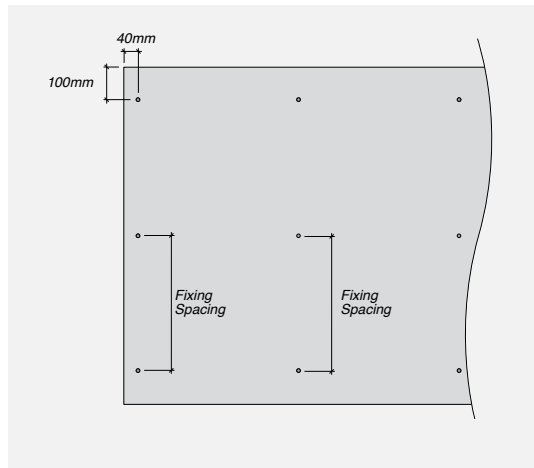
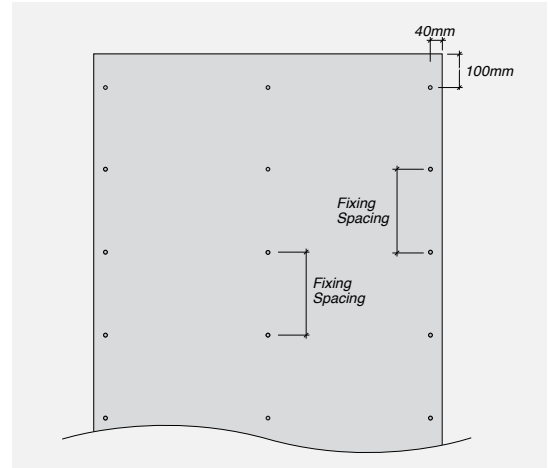

FIGURE 7.02 Vertical Sheet Fixing



Panels must be fixed in accordance with the tables set out in 'System Engineering' Section. This provides fixing Requirements and Maximum Rail Spacings for 1200mm wide panels based on 2 rails or 3 or more rails.

Installation for Timber and Steel Framing

Refer to 'System Engineering' and 'Construction Drawings and Details' sections for specific fixing information.

Step 1 – Install air barrier – as per Manufacturer's instructions.

Step 2 – Fix base flashing to base of wall over rigid air barrier taping top edge of flashing to air barrier.

Step 3 – Fix rails. Fix NV9 Omega rails horizontally where required to substrate as per 'System Engineering' section requirements. Fix NV9 Omega Rails vertically to horizontal rails as per 'System Engineering' section requirements.

Step 4 – Prepare panels. Cut panels as required. Run a fine sandpaper block along the edge of the cut panel (taking care not to scratch the panels surface). Seal cut edges with Cemintel's recommended edge sealant to protect against moisture entering the panels.

Step 5 – Pre-drill panel holes. This should be done prior to lifting panels into place and can be done off site. Panel holes need to be drilled a minimum 100mm from the horizontal edge and a minimum of 40mm from the vertical edge (refer to 'System Engineering Section').

For Surround rivets, use the recommended Cemintel 9.5mm carbide tipped drill bit with centreing tip (Refer Fig. 7.03).

The size of the hole drilled is designed to match the size of the rivet rubber sleeve. The use of other tools for this purpose may reduce fixing capacity and reduce the weather resistance of the system. DO NOT use hammering action when drilling. For efficiency you can neatly stack 3 or 4 sheets and drill through all at the same time. Take care to avoid damaging the panel with the drill chuck when approaching the end of the hole by using a timber block.

Clean/sweep away any dust from holes as this can stick to the panel.

FIGURE 7.03 Pre-drilling Panels

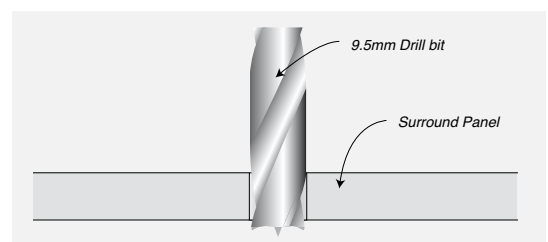

07

INSTALLATION

Step 6 – Install Vertical gaskets to the NV9 Omega Centre Trim installed into the NV(Omega Rails rails for the full extent of panels. Take care not to stretch the gasket when installing (Refer Fig. 7.04). When joining gasket, cut ends cleanly and push together before adhering. When the NV9 Omega Rails and Centre Trims are discontinuous, butt ends together tightly

and continue gasket over the joint.

At the beginning and end of a vertical joint, such as with sheets installed in a half-bond pattern, continue the vertical gasket past the horizontal joint by 100mm minimum (Refer Fig. 7.05).

FIGURE 7.04 Vertical Gasket

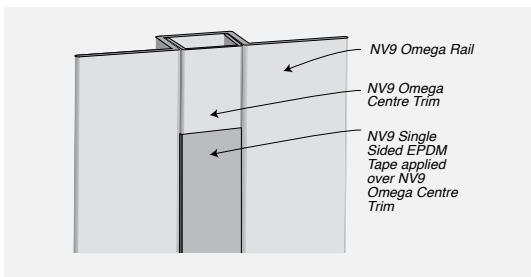
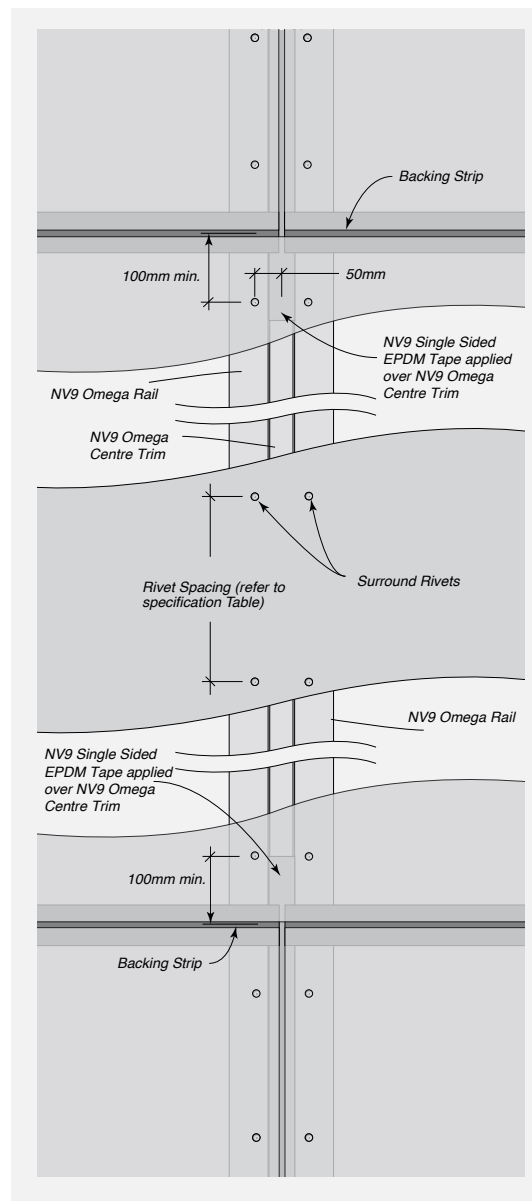
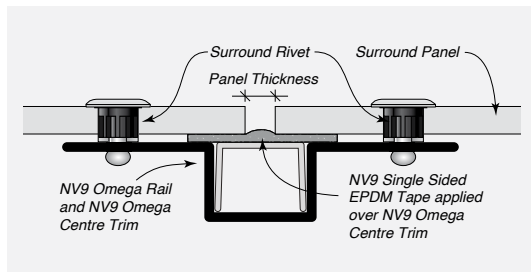
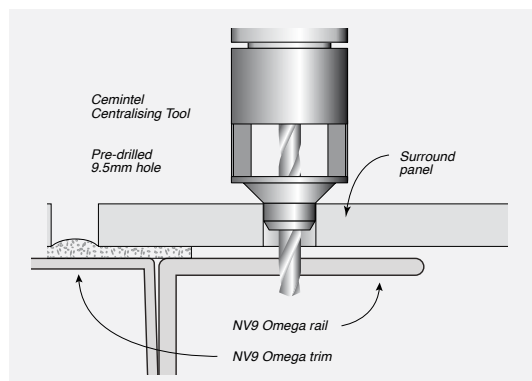

FIGURE 7.05 Vertical Gasket and Fixing Detail for Half-Bond Panel Layout



INSTALLATION

07

FIGURE 7.06 Vertical Joint Detail – Rivet Fixed**FIGURE 7.07** Centralising Tool**Step 7 – Install wall panels.**

Fixing panel – Lift panel into place, clamp down level to identify horizontal and vertical planes. Using the Rivet Centralising Tool, drill 4.1mm rivet holes through the pre-drilled panel holes into the top hats. This specialised tool creates a rivet hole, which matches the size of the shaft of the rivet, precisely in the centre of the panel hole (Refer Fig. 7.08).

Install Rivet Gun nose piece onto the Gesipa Accubird or Milwaukee battery operated blind rivet gun. The nose piece has a slight concave shape which serves to create a small (0.5mm) clearance between the panel face and the rivet flange. This enables differential movement of the frame while reducing damage to the panel face. Fix panel starting at the bottom corner. Place the rivet gun with the rivet gun head onto the rivet shaft. Push the panel firmly against the framing/gaskets and operate the gun to pull the rivet through panel hole into the predrilled top hat.

Before fixing top rivets to panel, insert Surround Angled Backing Strip along horizontal joint. Clip corners at an angle and bend. Surround Panels

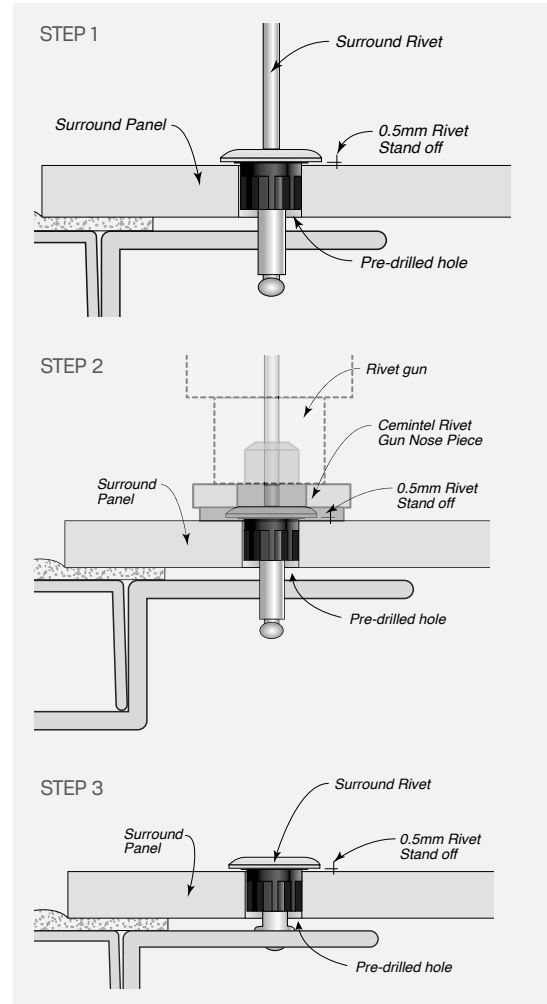
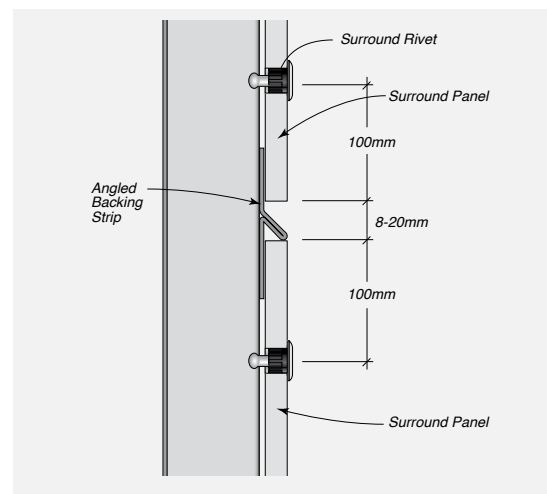
FIGURE 7.08 Fixing with Rivets**FIGURE 7.09** Horizontal Joint with Angled Backing Strip

07

INSTALLATION

are generally installed with a nominal 8-10mm wide expressed joint in both horizontal and vertical directions (a small cut piece of panel can be used as a spacer to easily measure joint widths and ensure consistency). Once positioned, fasten top row of rivets.

Sealant filled joints only – When using the ExpressWall backing strip, ensure ExpressWall backing strip is 6mm shorter overall than the width of the panel (cut to length if necessary).

A fillet of Sikaflex 11FC is then placed along the top edge of the panel. This ensures that the joint drains

and salt and dirt do not build up in the joint.

To seal the groove in the backing strip at the ends, apply a small section of gasket to the rear of the backing strip. This will be forced into the recess and seal the end of the strip. Alternatively use Sikaflex 11FC to fill the groove.

Joint widths – While panels are generally installed with a nominal 8-10mm wide horizontal and vertical expressed joint. However joints up to 20mm can be formed provided additional care is taken during installation to ensure that panel edges cover the joint gaskets by a minimum of 10mm.

FIGURE 7.10 Backing Strip Positioning

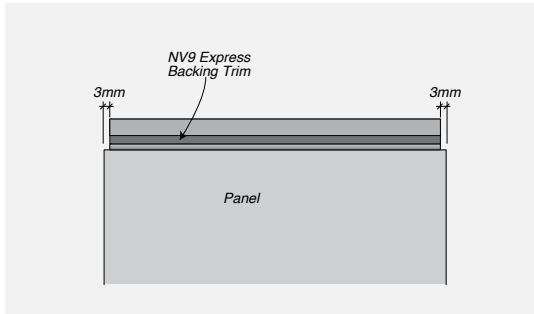

FIGURE 7.11 Horizontal Joint

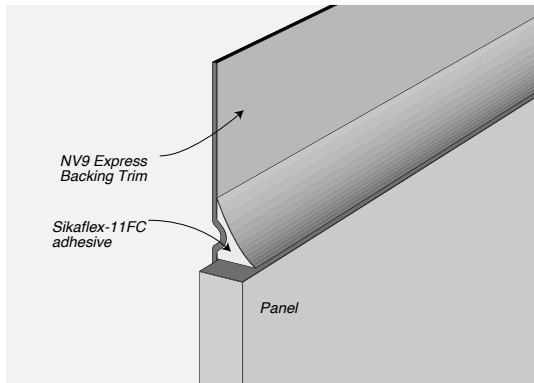

FIGURE 7.12 Sealing Ends of Backing Strip

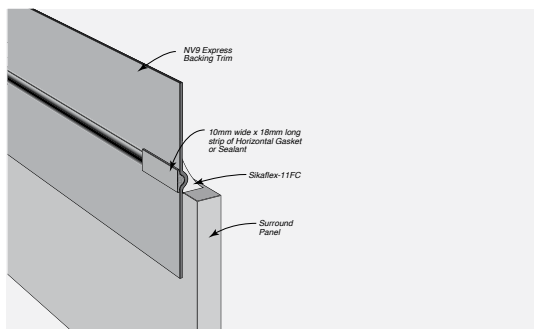

FIGURE 7.13 Vertical Joint

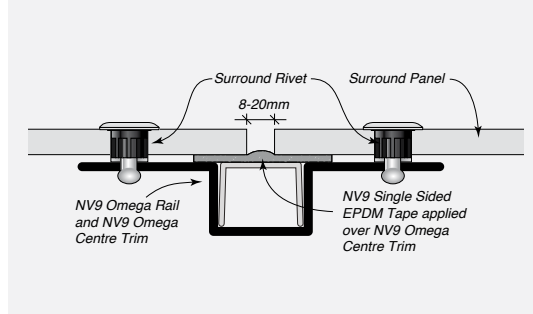
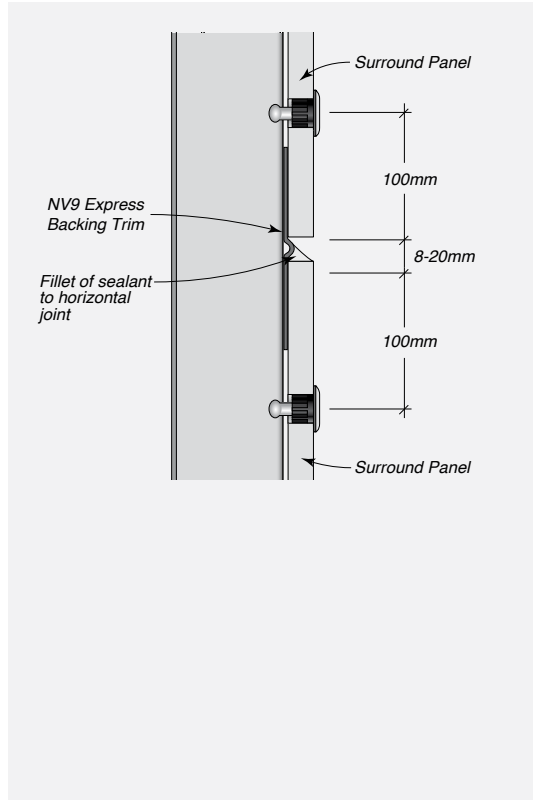

FIGURE 7.14 Horizontal Joint



INSTALLATION

07

In certain conditions such as corrosive environments or where there is a preference to have flush sealed joints, horizontal and vertical joints may be filled with recommended joint sealant and in accordance with manufacturer's instructions. Base of walls including horizontal joints at inter-storey junctions must

remain open, to allow pressure equalisation to be maintained and for any water moisture to drain from the cavity. Refer to the sealant filled joint details of the "Construction Drawings and Details" section of this manual.

FIGURE 7.15 Joint Construction – Sealed Option

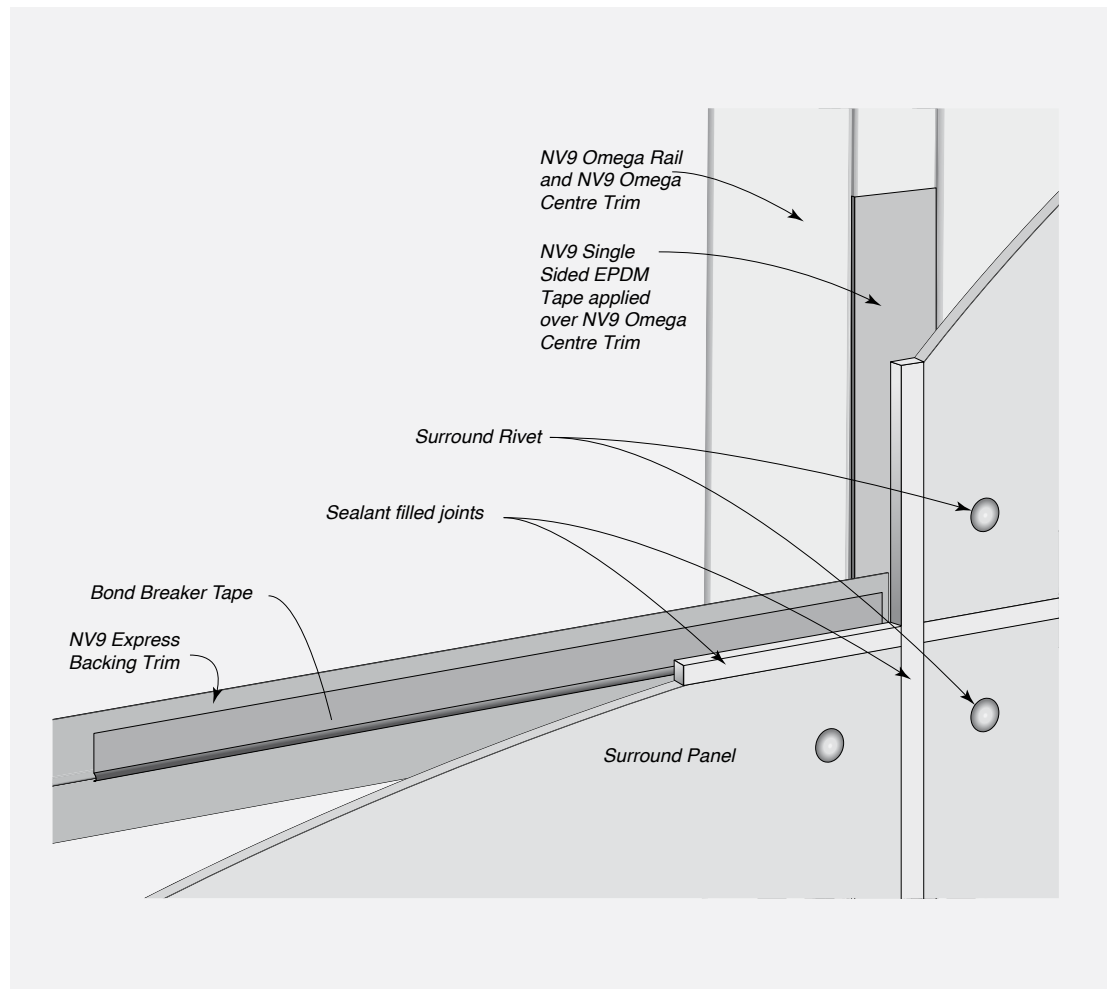

07

INSTALLATION

FIGURE 7.16 Horizontal Joint Sealed Side

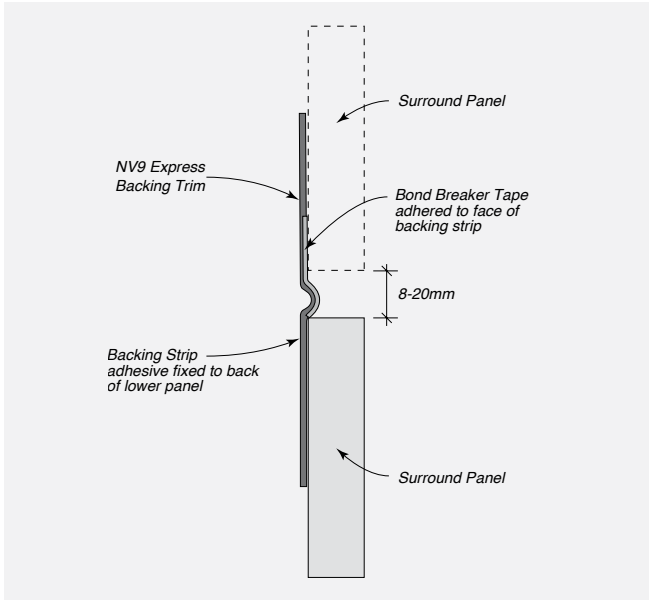

FIGURE 7.19 Horizontal Joint Sealed Side

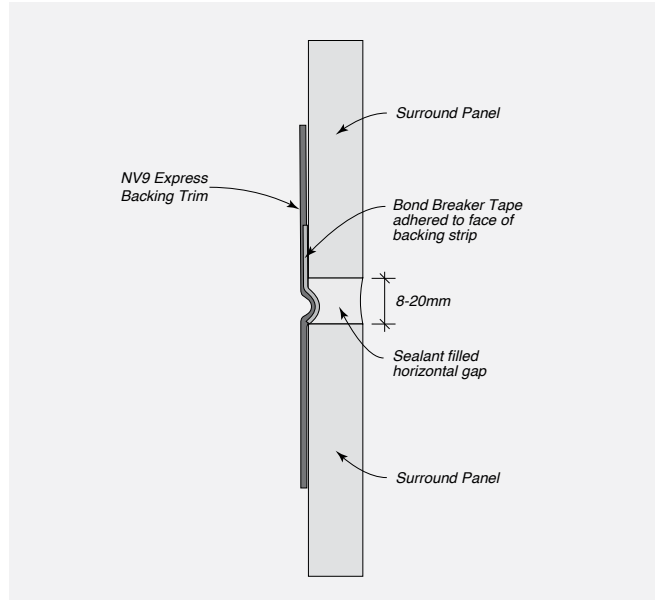

FIGURE 7.17 Horizontal Joint Fixing – Sealed Option

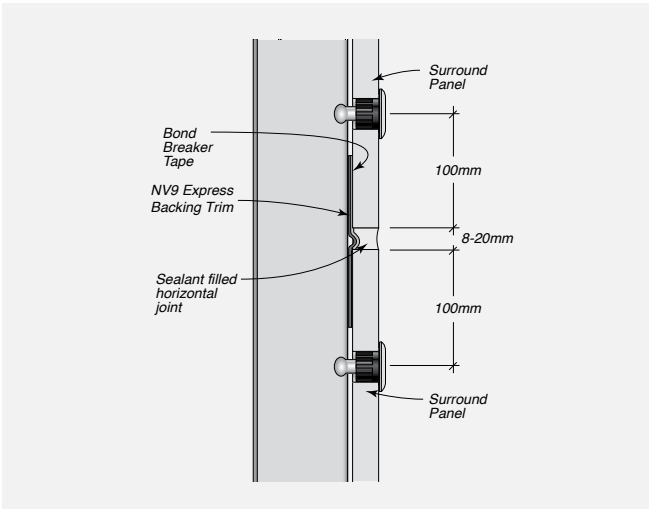

FIGURE 7.20 Backing Strip & Bond Breaker Tape

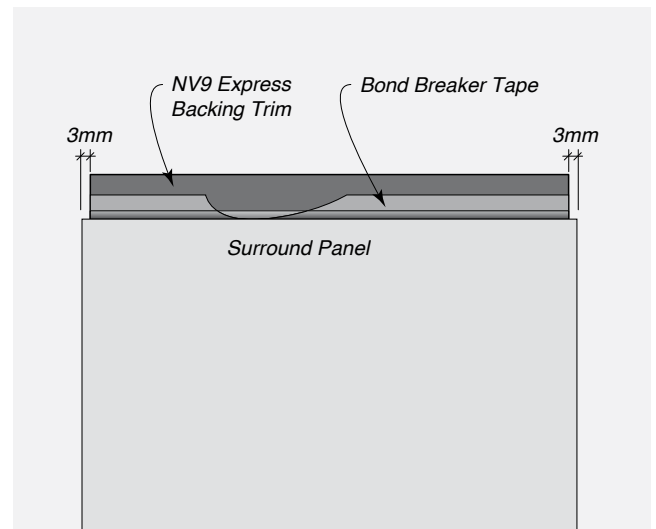
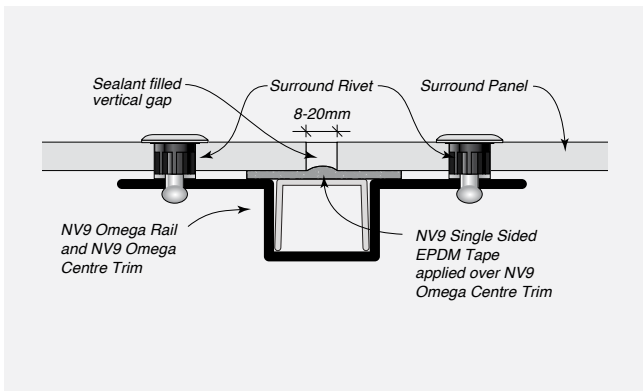

FIGURE 7.18 Vertical Joint – Sealed Option





CONSTRUCTION
DRAWINGS + DETAILS



CONSTRUCTION DRAWINGS AND DETAILS

Note: Drawings are interchangeable for timber or steel substrates with the exception of the fasteners.

Drawings Index

SECTION	DESCRIPTION	FIGURE REFERENCE	PAGE NUMBER
VENTILATED CAVITY SYSTEM			
Overview	Joint Construction – Ventilated Cavity System	8.01	39
Joint Details	Horizontal Joint – Sealant Filled	8.02	40
	Horizontal Joint – Angled Backing Strip	8.03	40
	Vertical Joint – Rivet	8.04	40
Cross Section Details	Typical System Cross Section for Steel Framing	8.05	41
Head Details	Eaves/Deflection Head – Ventilated	8.06	41
Base Details	Base Detail – Drained	8.07	41
Corner Details	External Corner	8.08	42
	External Corner – Obtuse Angle	8.09	42
	Internal Corner Detail	8.10	42
Junction Details	Framed Soffit	8.11	43
	Control Joint – Vertical	8.12	43
	Inter-Storey Junction with Flashing	8.13	43
	Abutment	8.14	44
	Vertical Gasket and Fixing Detail for Half-bond Panel Layout	8.15	44
Window Details	Typical Commercial Window Installation - Head	8.16	44
	Typical Commercial Window Installation - Sill	8.17	44
	Typical Commercial Window Installation - Jam	8.18	45
	Typical Residential Window Installation - Head	8.19	45
	Typical Residential Window Installation - Sill	8.20	45
	Typical Residential Window Installation - Jam	8.21	45
Parapet Capping	Parapet Capping	8.22	46
Drain	Typical Penetration	8.23	46
Power/Meter Box Details	Typical Power/Meter Box	8.24	46
VENTILATED CAVITY SYSTEM – SEALANT FILLED JOINT DETAILS			
Overview	Sealant Filled Joint Construction – Ventilated Cavity System	8.25	47
Joint Details – Sealant filled	Backing Strip Preparation	8.26	47
	Horizontal Joint – Sealant filled	8.27	47
	Vertical Joint – Sealant filled	8.28	47
Cross Section Details – Sealant filled	Typical System Cross Section for Steel Framing – Joints sealant filled	8.29	48
Head Detail – Sealant filled	Eaves/Deflection Head – Sealant filled	8.30	48
Base Detail – Drained	Base Detail – Drained	8.31	48
Corner Details – Sealant filled	Internal Corner Detail – Sealant filled	8.32	49
	External Corner – Sealant filled	8.33	49

CONSTRUCTION DRAWINGS AND DETAILS

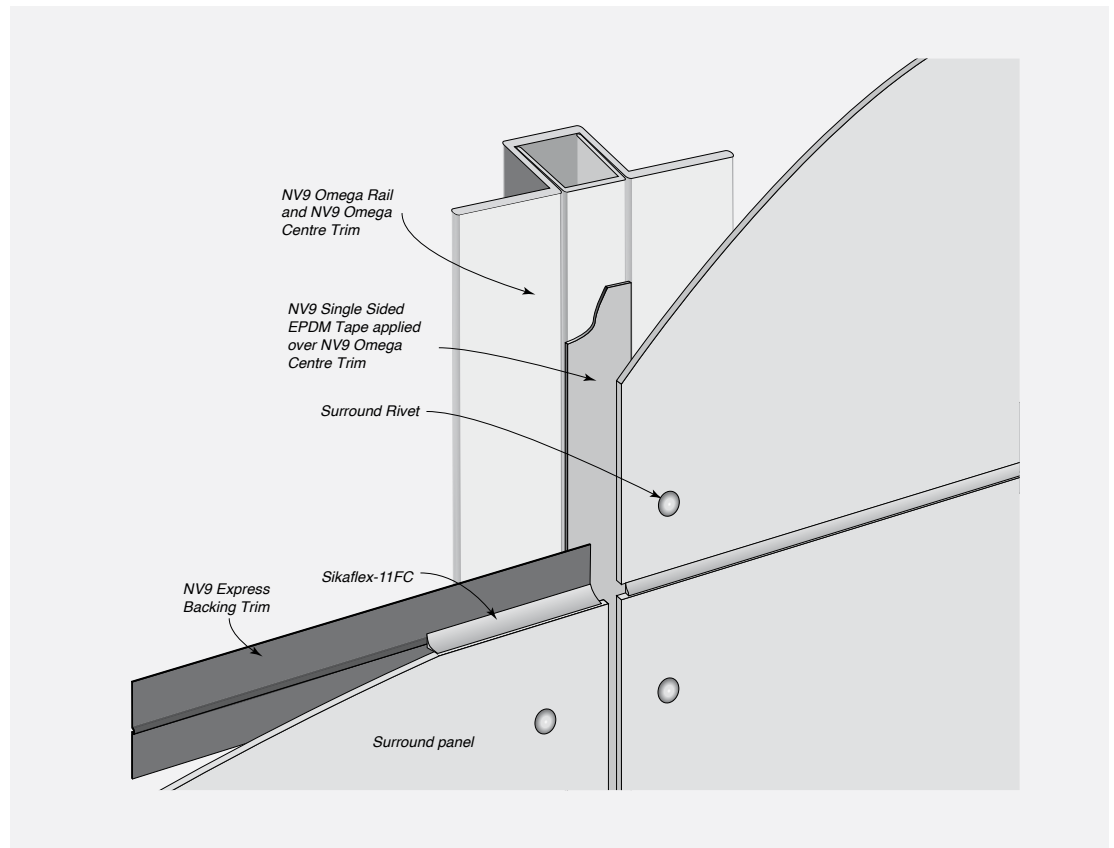

Note: Drawings are interchangeable for timber or steel substrates with the exception of the fasteners.

Pressure Equalised – Ventilated Cavity System**FIGURE 8.01** Joint Construction - Ventilated Cavity System



CONSTRUCTION DRAWINGS AND DETAILS

Note: Drawings are interchangeable for timber or steel substrates with the exception of the fasteners.

Pressure Equalised – Ventilated Cavity System

FIGURE 8.02 Horizontal Joint – Sealant Filled

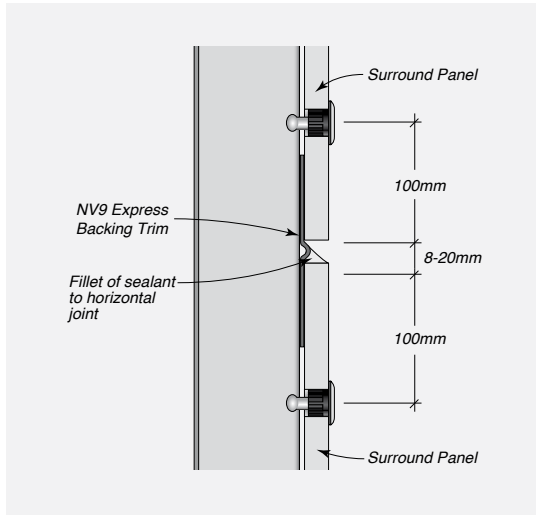

FIGURE 8.03 Horizontal Joint – Angled Backing Strip

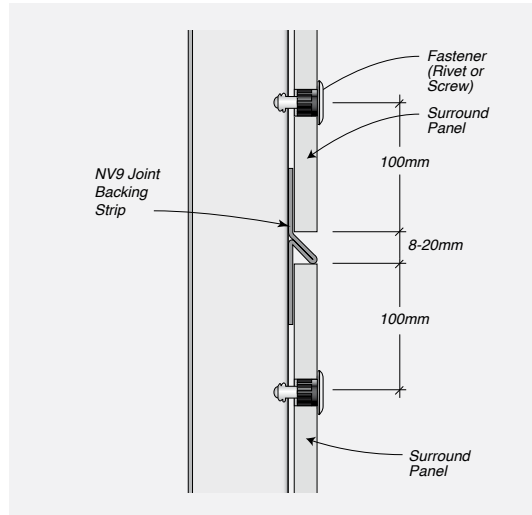
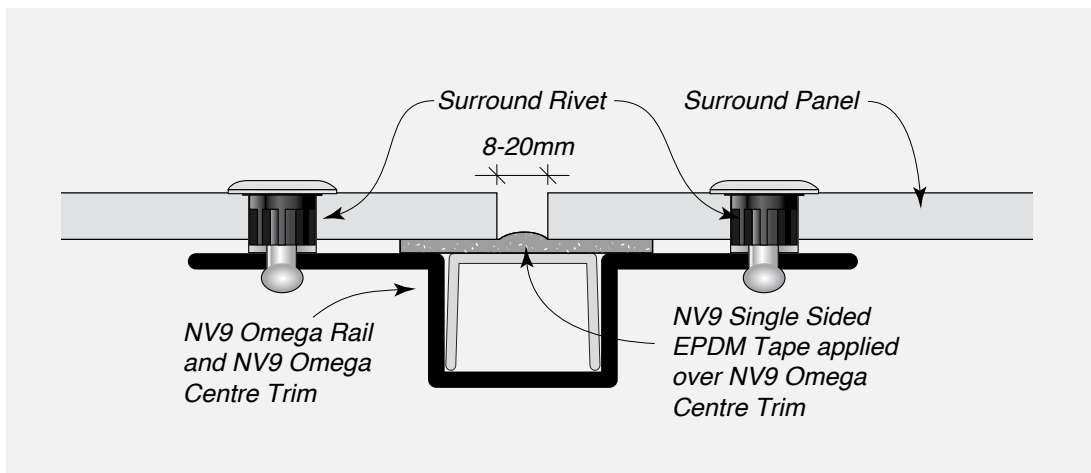

FIGURE 8.04 Vertical Joint – Rivet



CONSTRUCTION DRAWINGS AND DETAILS



Note: Drawings are interchangeable for timber or steel substrates with the exception of the fasteners.

Pressure Equalised – Ventilated Cavity System

FIGURE 8.05 Typical System Cross Section for Steel Framing

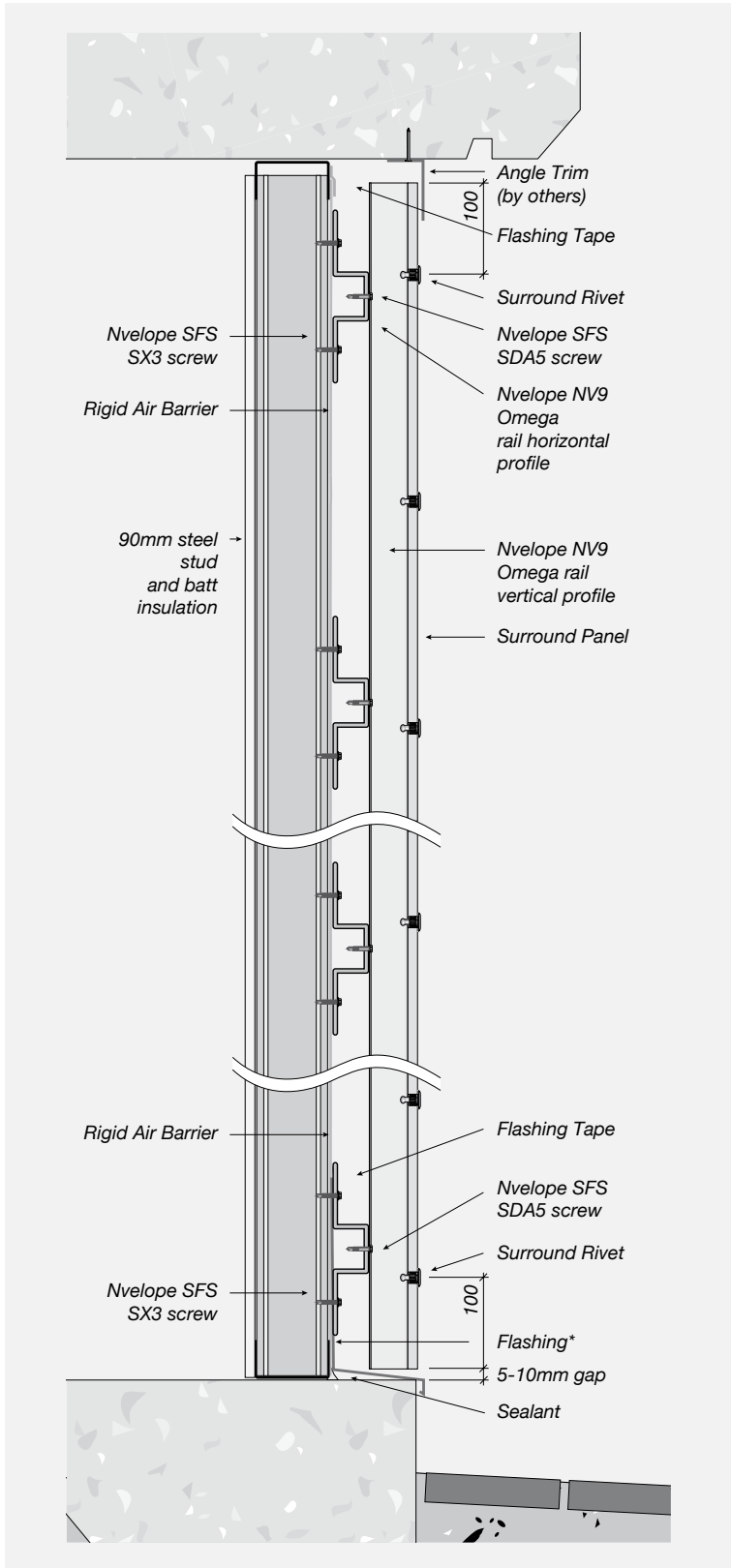

FIGURE 8.06 Eaves/Deflection Head – Ventilated

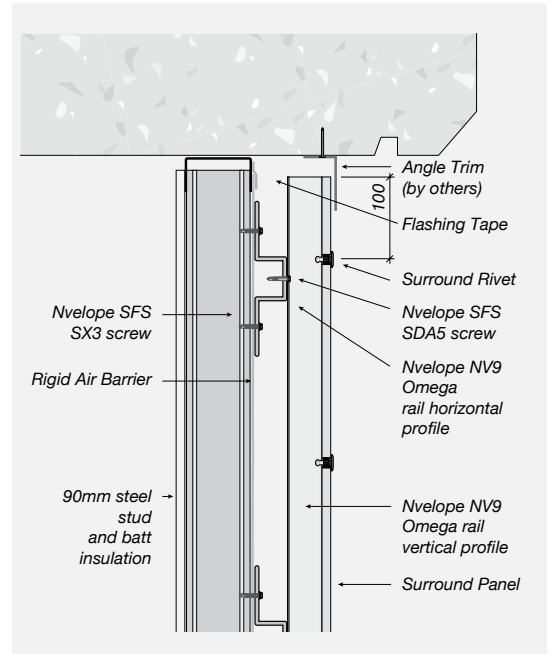
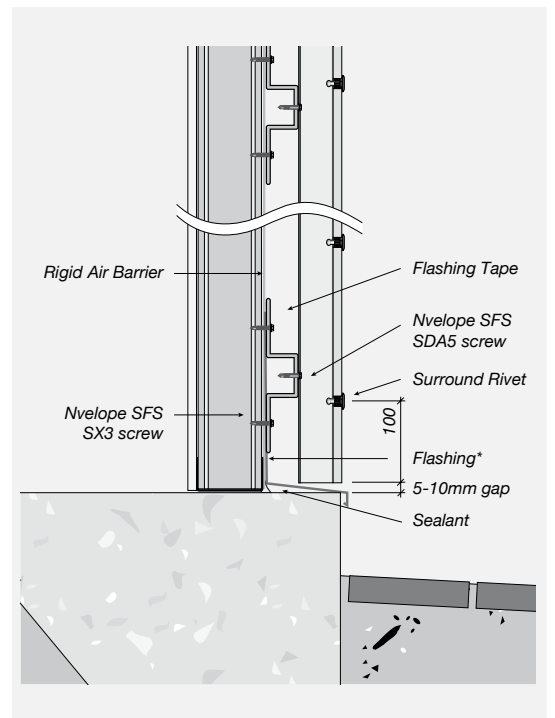

FIGURE 8.07 Base Detail – Drained





CONSTRUCTION DRAWINGS AND DETAILS

Note: Drawings are interchangeable for timber or steel substrates with the exception of the fasteners.

Pressure Equalised – Ventilated Cavity System

FIGURE 8.08 External Corner

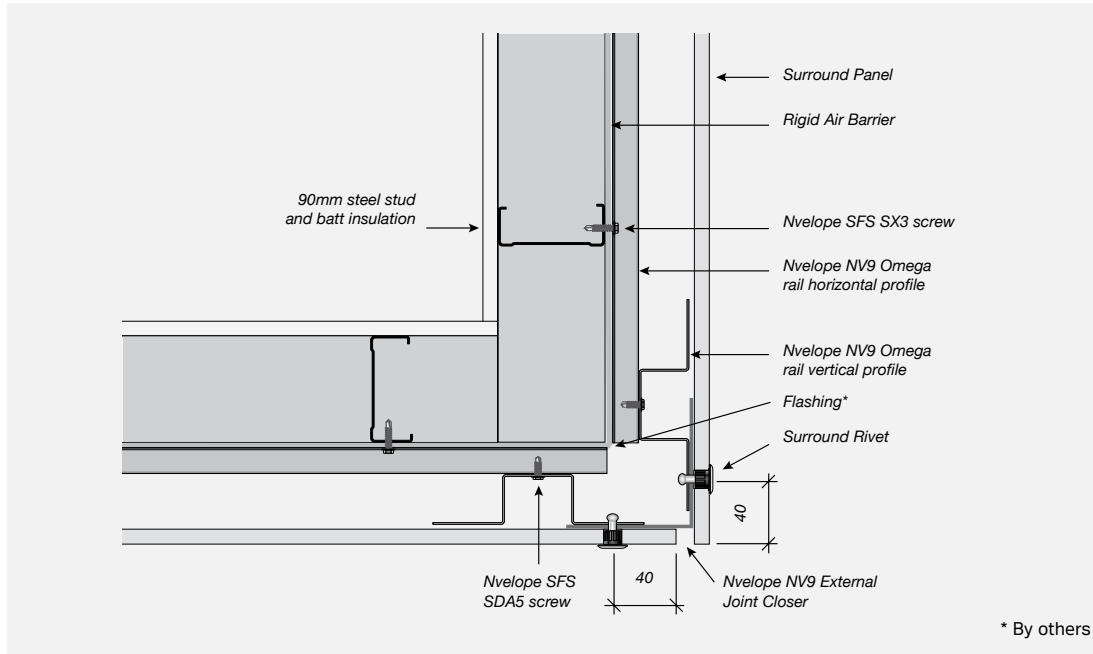

FIGURE 8.09 External Corner – Obtuse Angle

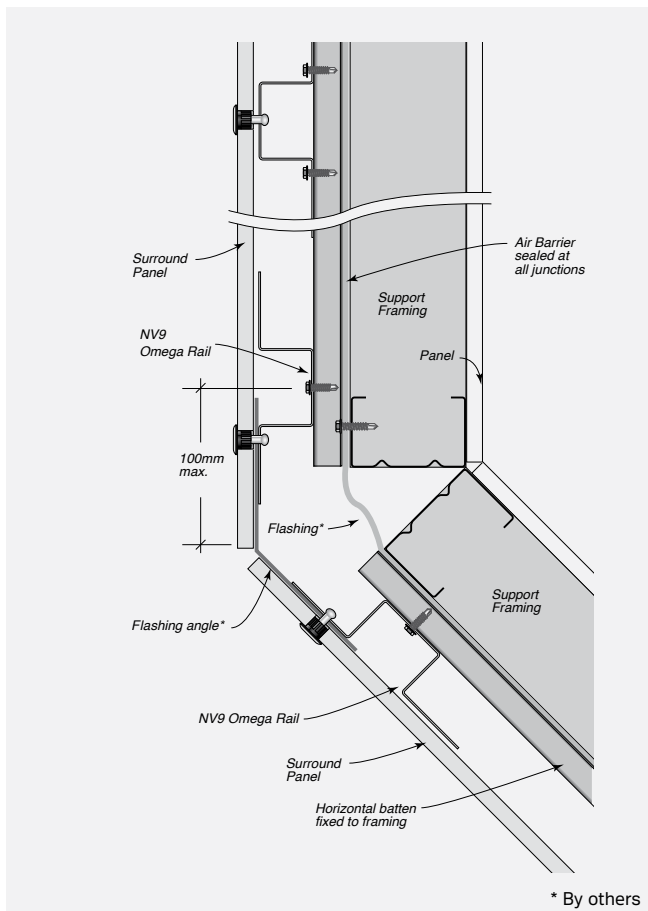
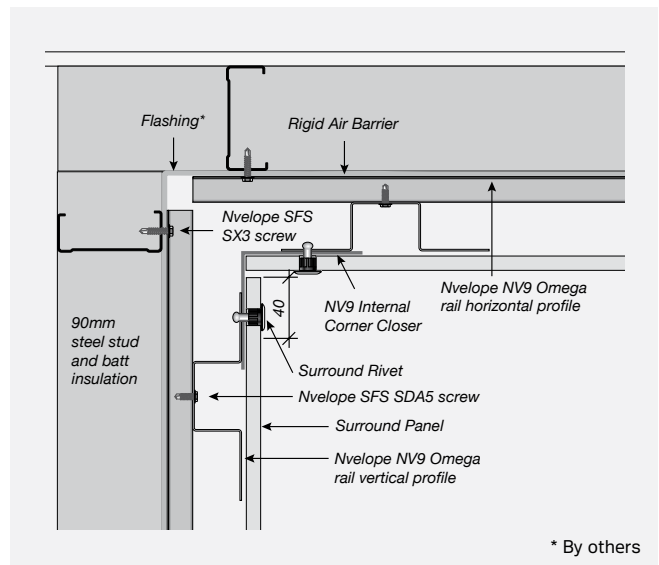

FIGURE 8.10 Internal Corner Detail



CONSTRUCTION DRAWINGS AND DETAILS



Note: Drawings are interchangeable for timber or steel substrates with the exception of the fasteners.

Pressure Equalised – Ventilated Cavity System

FIGURE 8.11 Framed Soffit

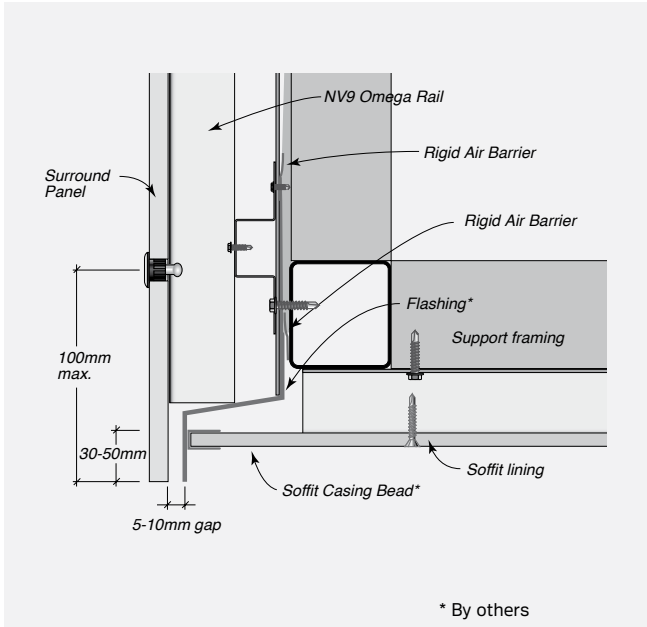

FIGURE 8.12 Control Joint – Vertical

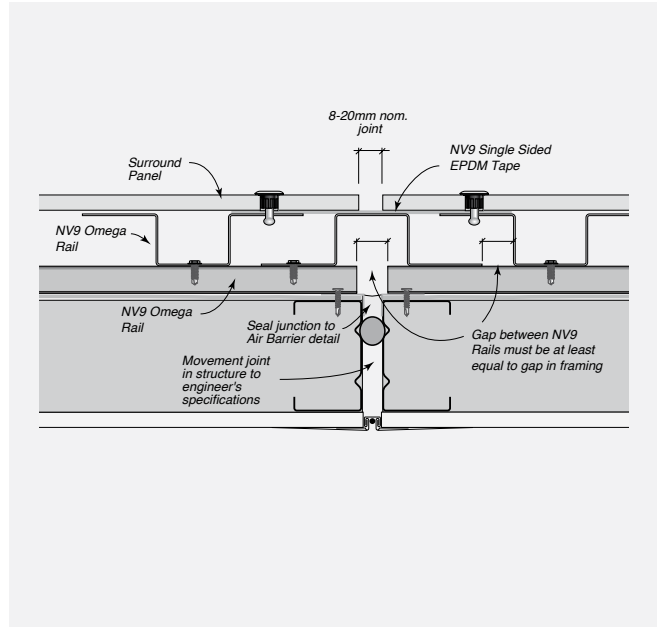
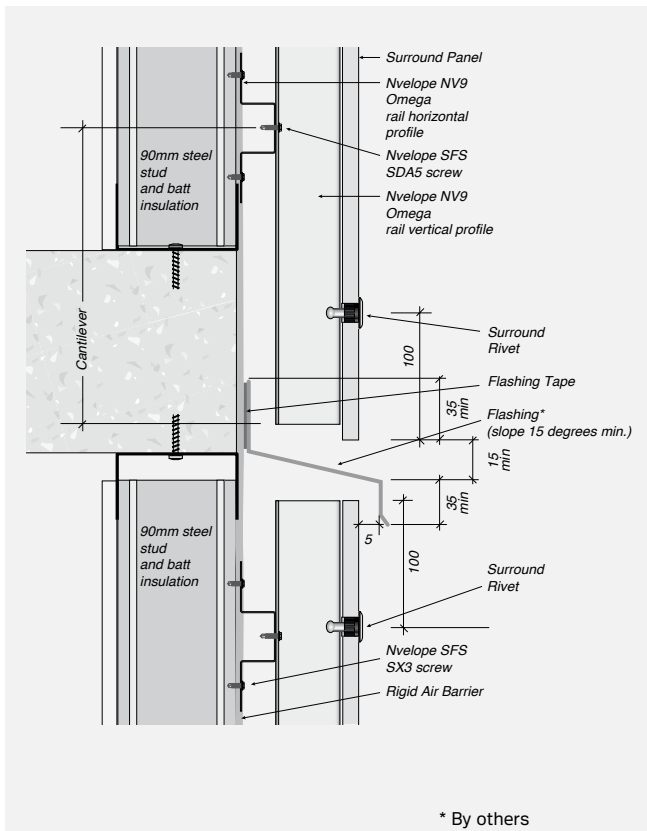

FIGURE 8.13 Inter-Storey Junction with Flashing





CONSTRUCTION DRAWINGS AND DETAILS

Note: Drawings are interchangeable for timber or steel substrates with the exception of the fasteners.

Pressure Equalised - Ventilated Cavity System

FIGURE 8.14 Abutment

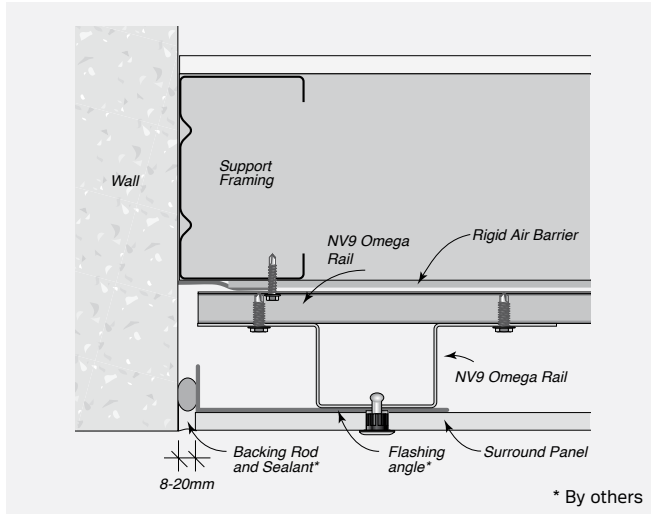

FIGURE 8.15 Vertical Gasket and Fixing Detail for Half-bond Panel Layout

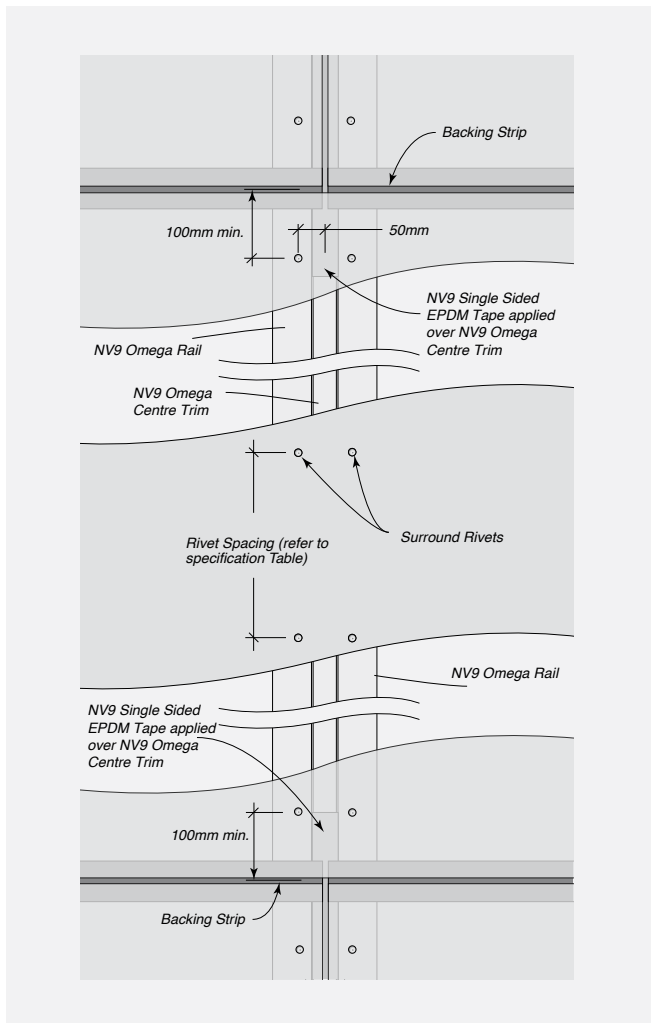

FIGURE 8.16 Typical Commercial Window Installation - Head

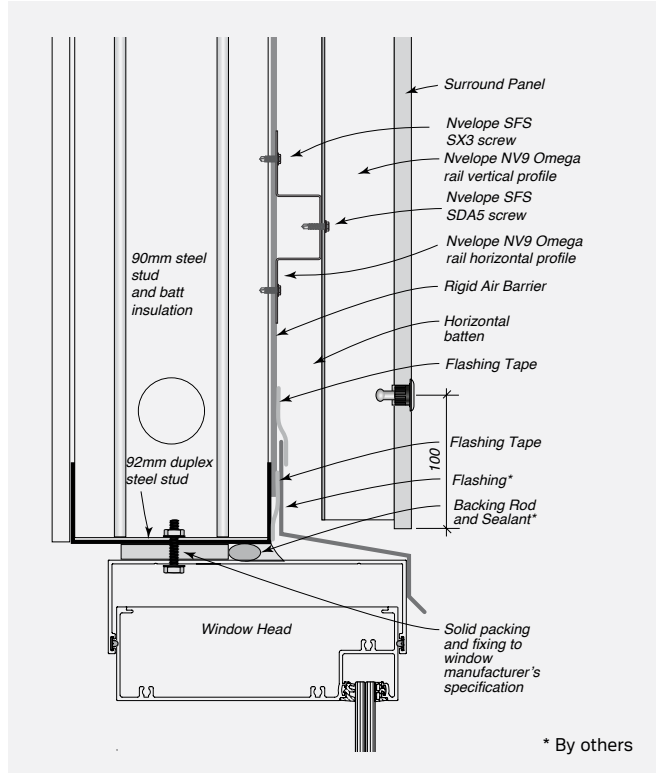
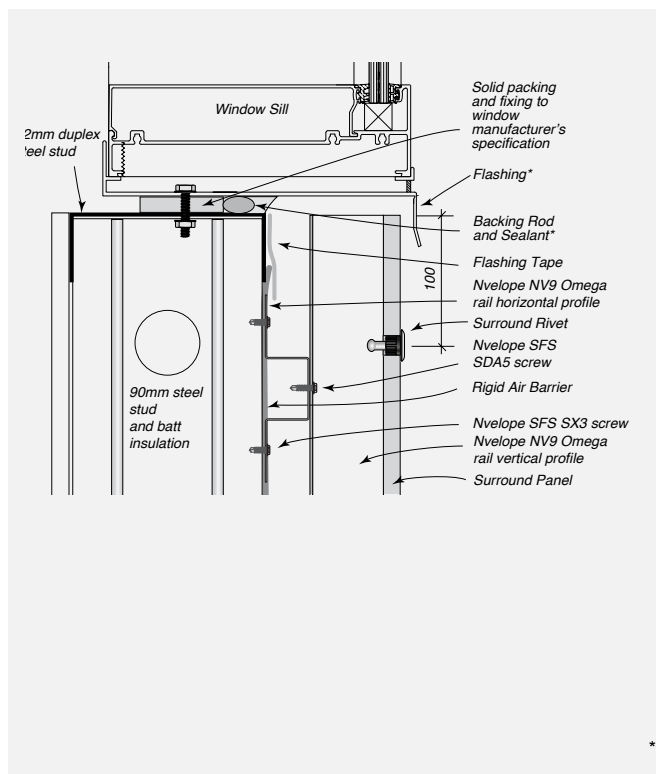

FIGURE 8.17 Typical Commercial Window Installation - Sill



CONSTRUCTION DRAWINGS AND DETAILS



Note: Drawings are interchangeable for timber or steel substrates with the exception of the fasteners.

Pressure Equalised – Ventilated Cavity System

FIGURE 8.18 Typical Commercial Window Installation - Jam

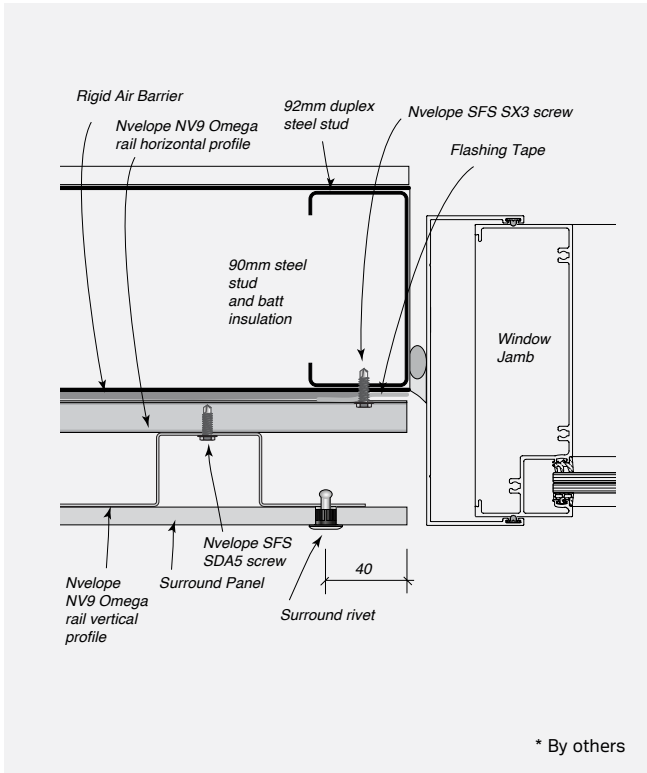

FIGURE 8.20 Typical Residential Window Installation - Sill

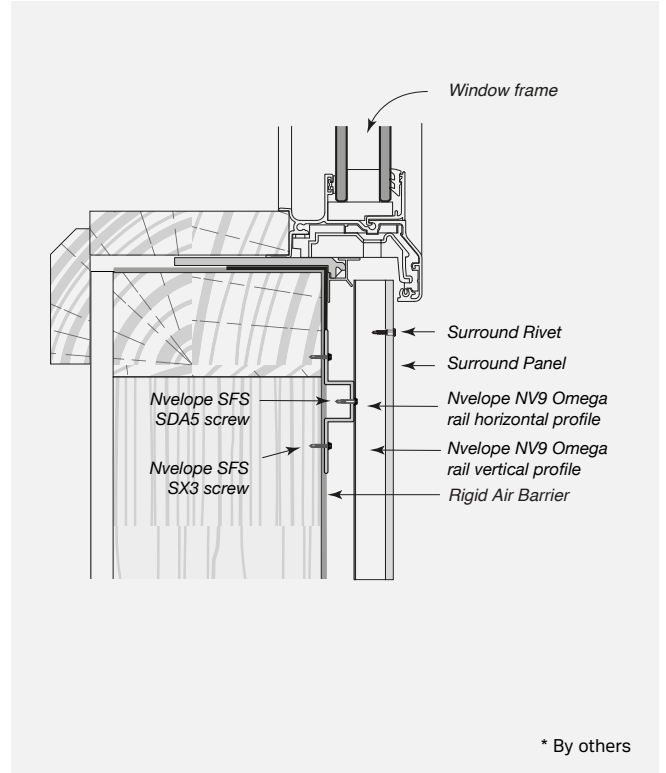

FIGURE 8.19 Typical Residential Window Installation - Head

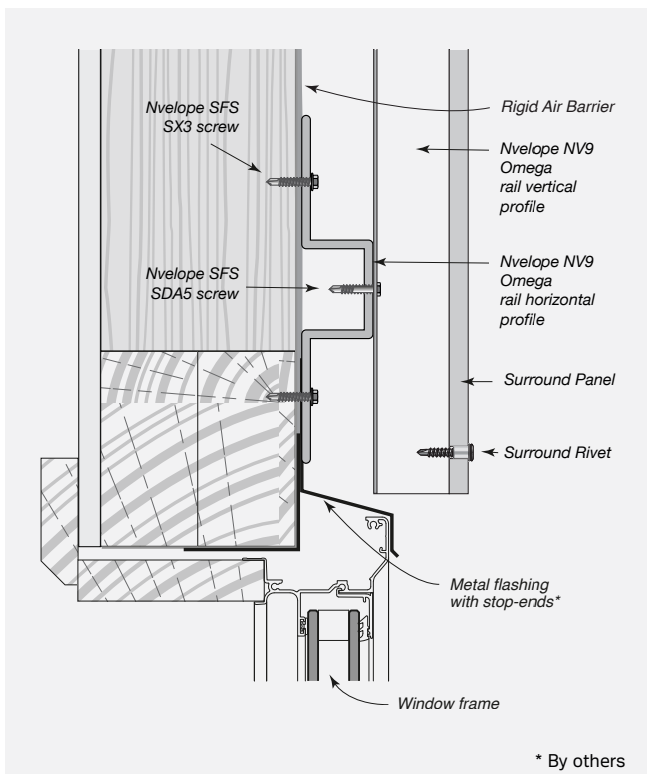
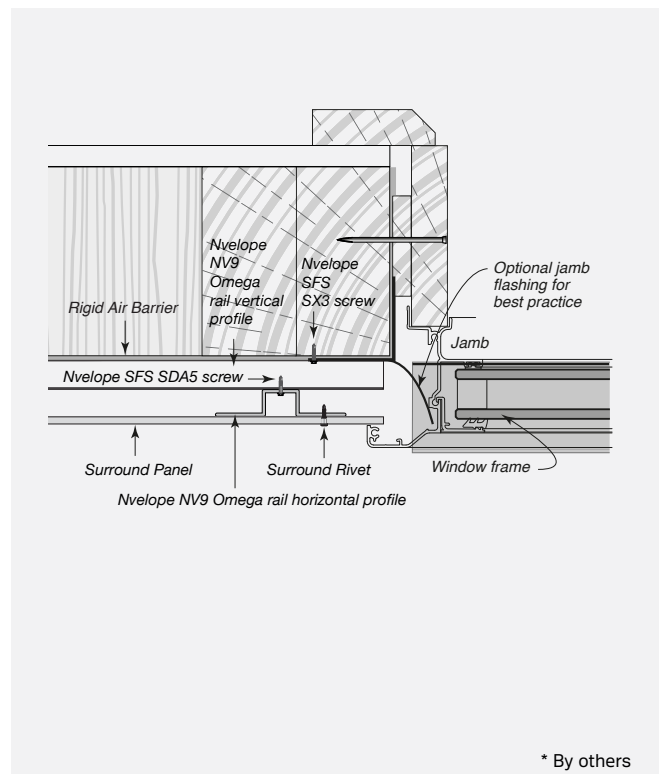

FIGURE 8.21 Typical Residential Window Installation - Jam





CONSTRUCTION DRAWINGS AND DETAILS

Note: Drawings are interchangeable for timber or steel substrates with the exception of the fasteners.

Pressure Equalised – Ventilated Cavity System

FIGURE 8.22 Parapet Capping

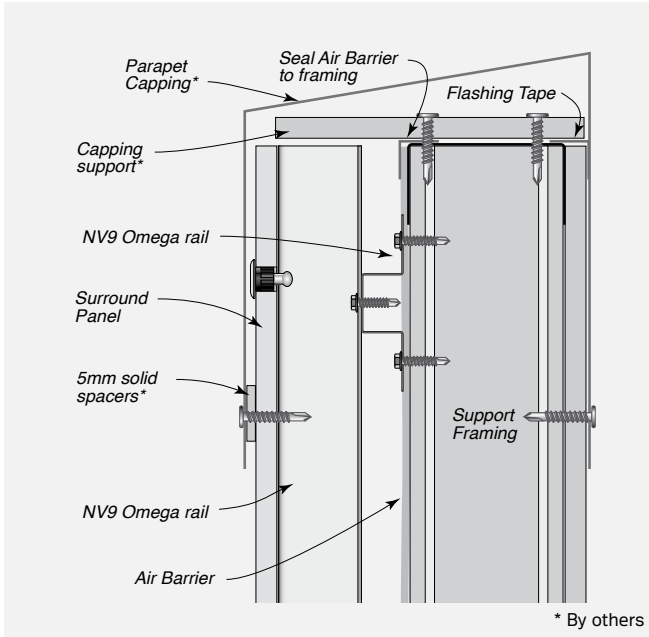

FIGURE 8.23 Typical Penetration

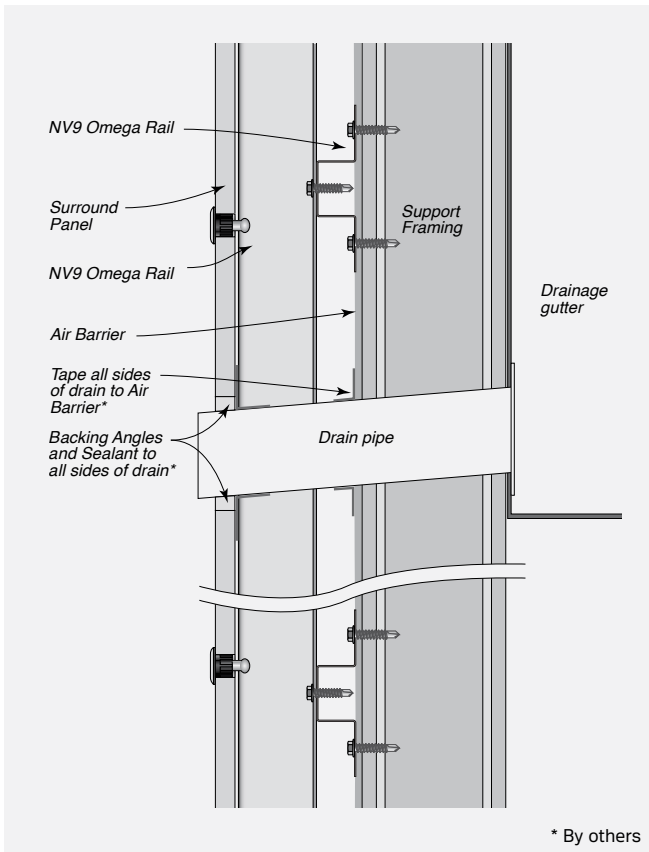
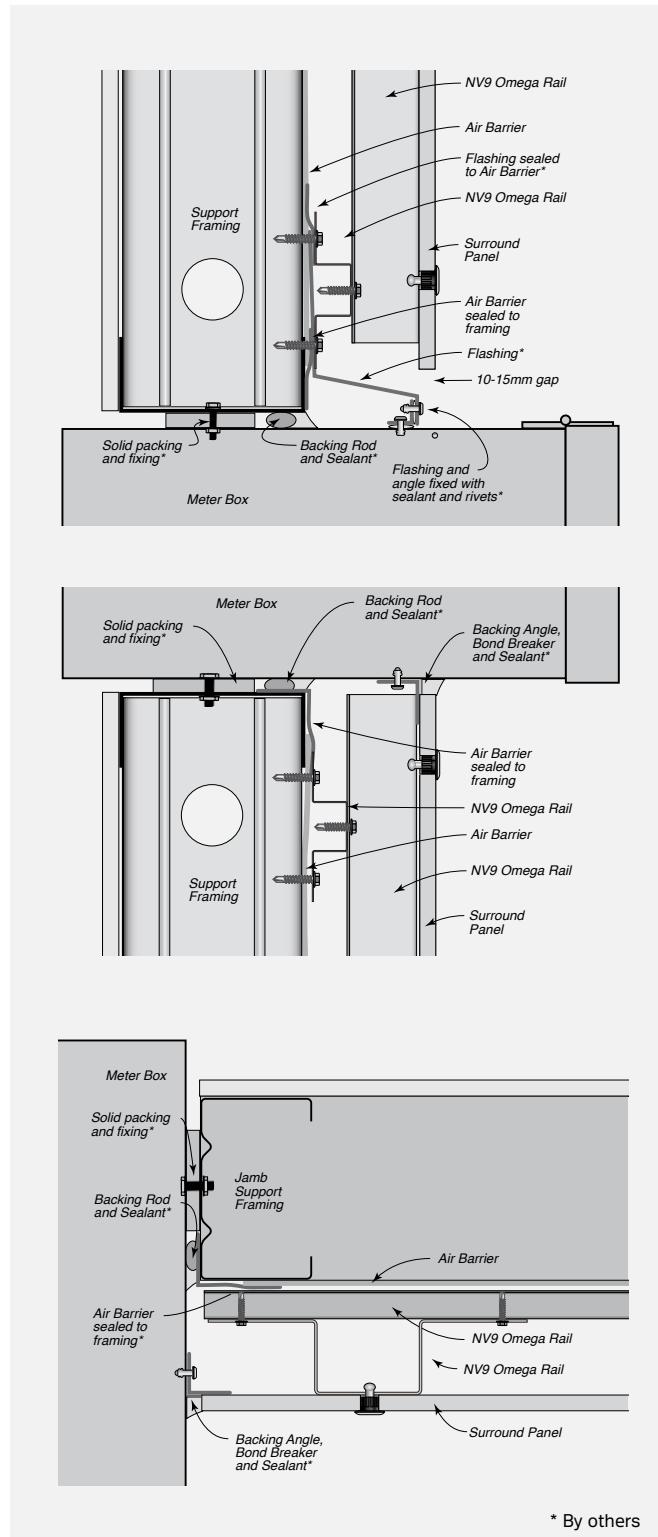

FIGURE 8.24 Typical Power/Meter Box

Note: Refer to local authority for specific meter box installation requirements.



CONSTRUCTION DRAWINGS AND DETAILS



Note: Drawings are interchangeable for timber or steel substrates with the exception of the fasteners.

Pressure Equalised – Ventilated Cavity System – Sealant Filled Joint Details

FIGURE 8.25 Sealant Filled Joint Construction – Ventilated Cavity System

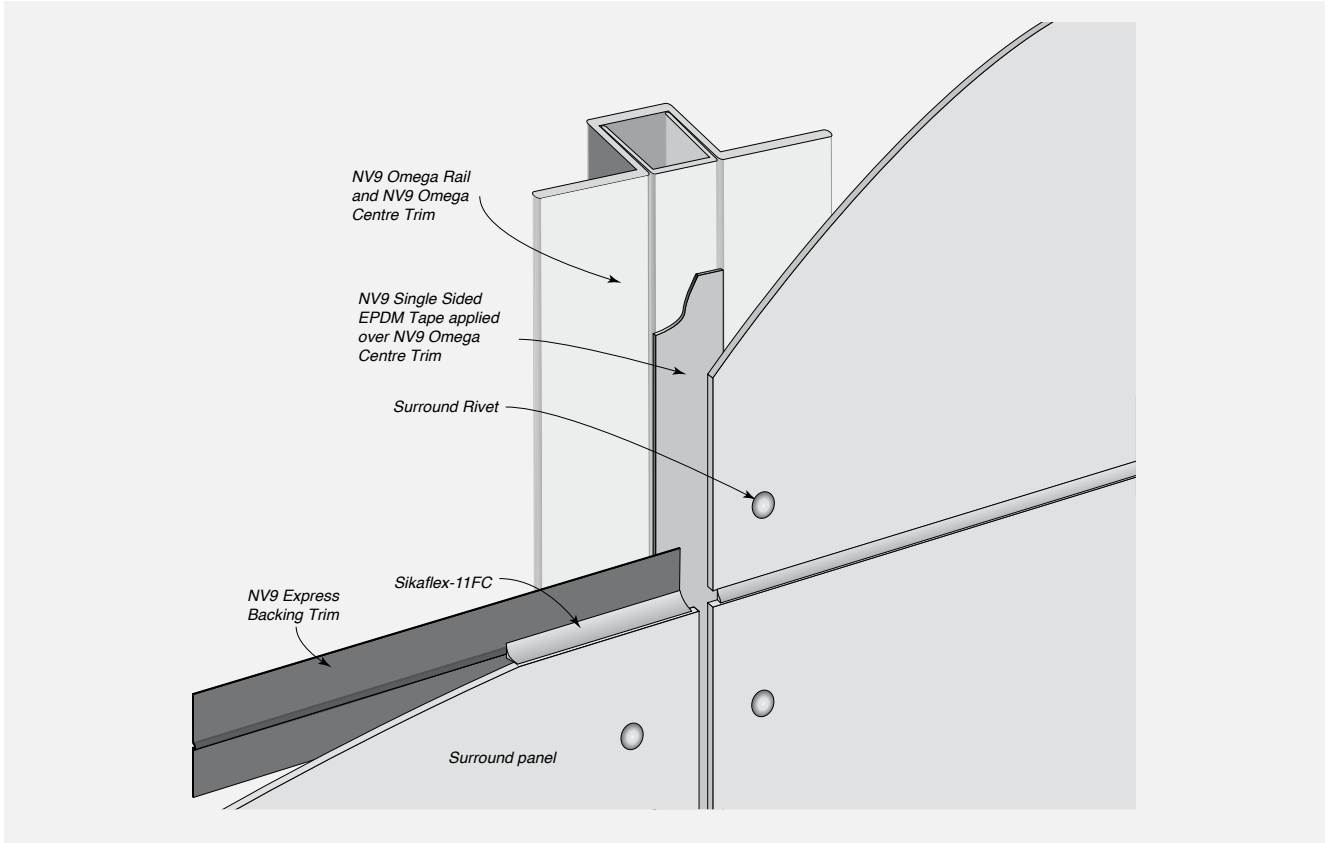

FIGURE 8.26 Backing Strip Preparation

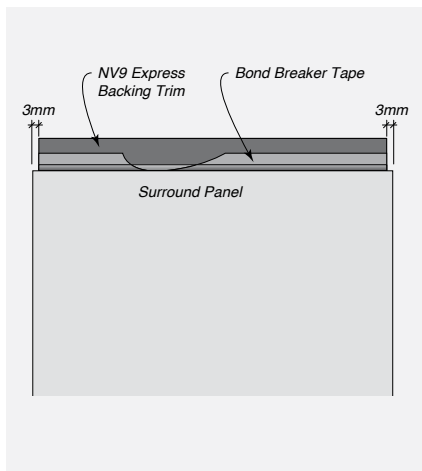

FIGURE 8.27 Horizontal Joint – Sealant filled

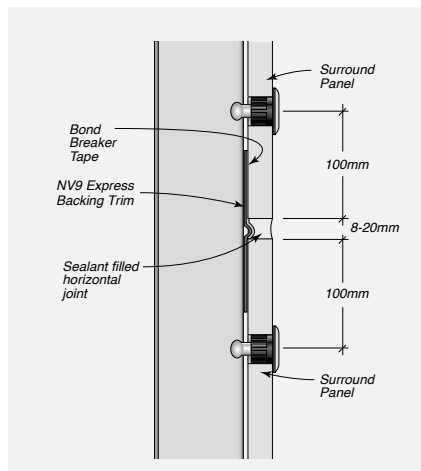
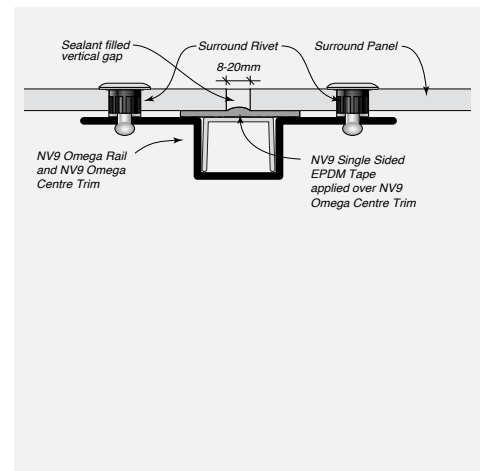

FIGURE 8.28 Vertical Joint – Sealant filled





CONSTRUCTION DRAWINGS AND DETAILS

Note: Drawings are interchangeable for timber or steel substrates with the exception of the fasteners.

Pressure Equalised – Ventilated Cavity System – Sealant Filled Joint Details

FIGURE 8.29 Typical System Cross Section for Steel Framing – Joints sealant filled

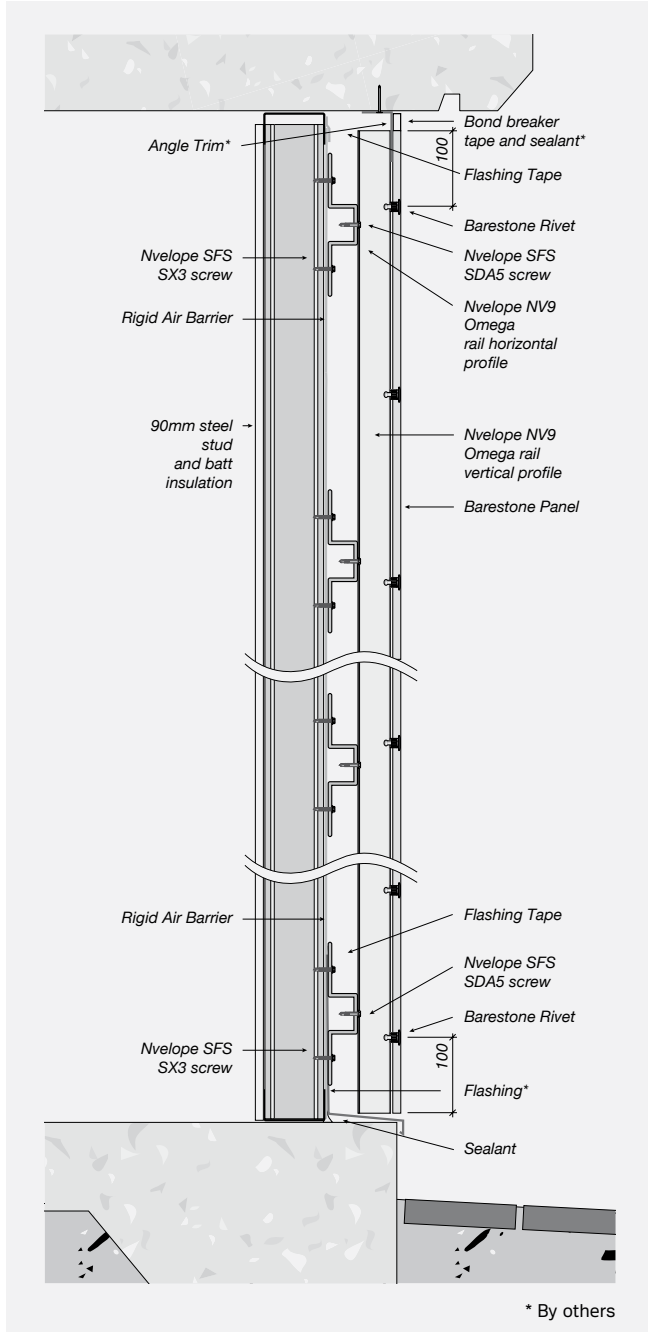

FIGURE 8.30 Eaves/Deflection Head – Sealant filled

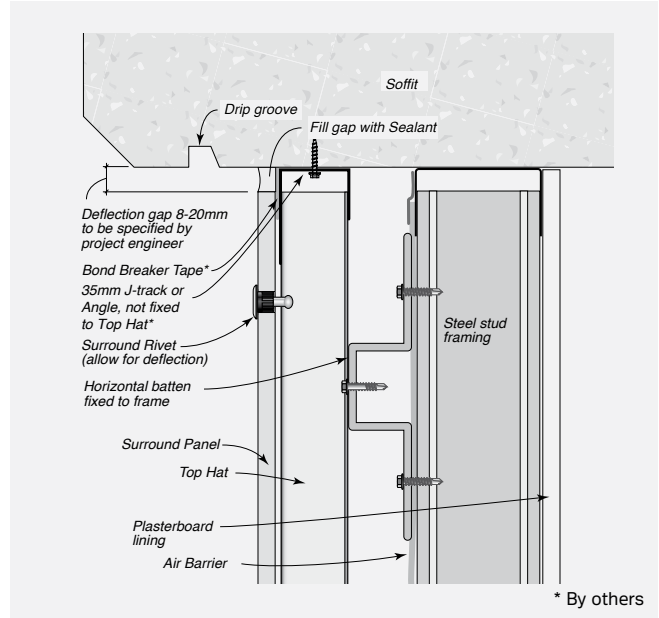
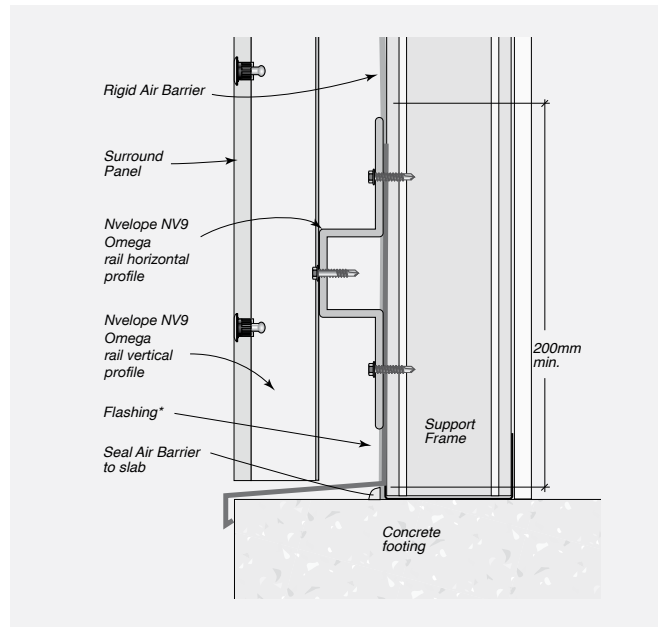

FIGURE 8.31 Base Detail – Drained



CONSTRUCTION DRAWINGS AND DETAILS



Note: Drawings are interchangeable for timber or steel substrates with the exception of the fasteners.

Pressure Equalised – Ventilated Cavity System – Sealant Filled Joint Details

FIGURE 8.32 Internal Corner Detail – Sealant filled

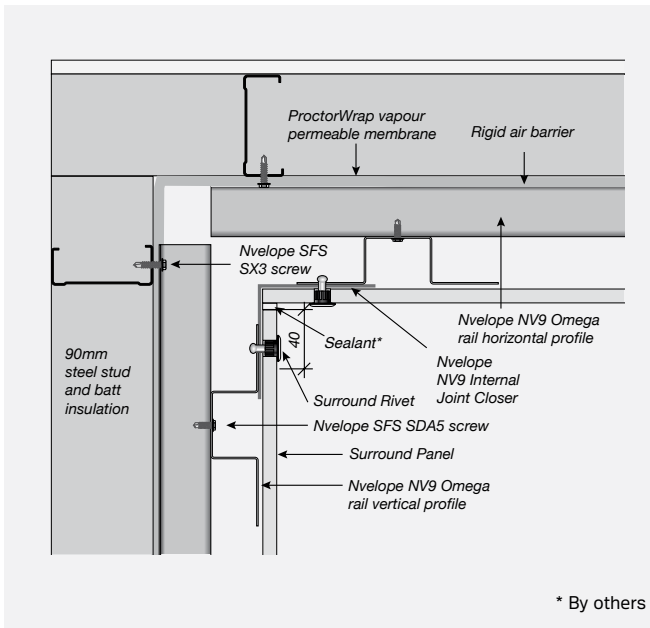
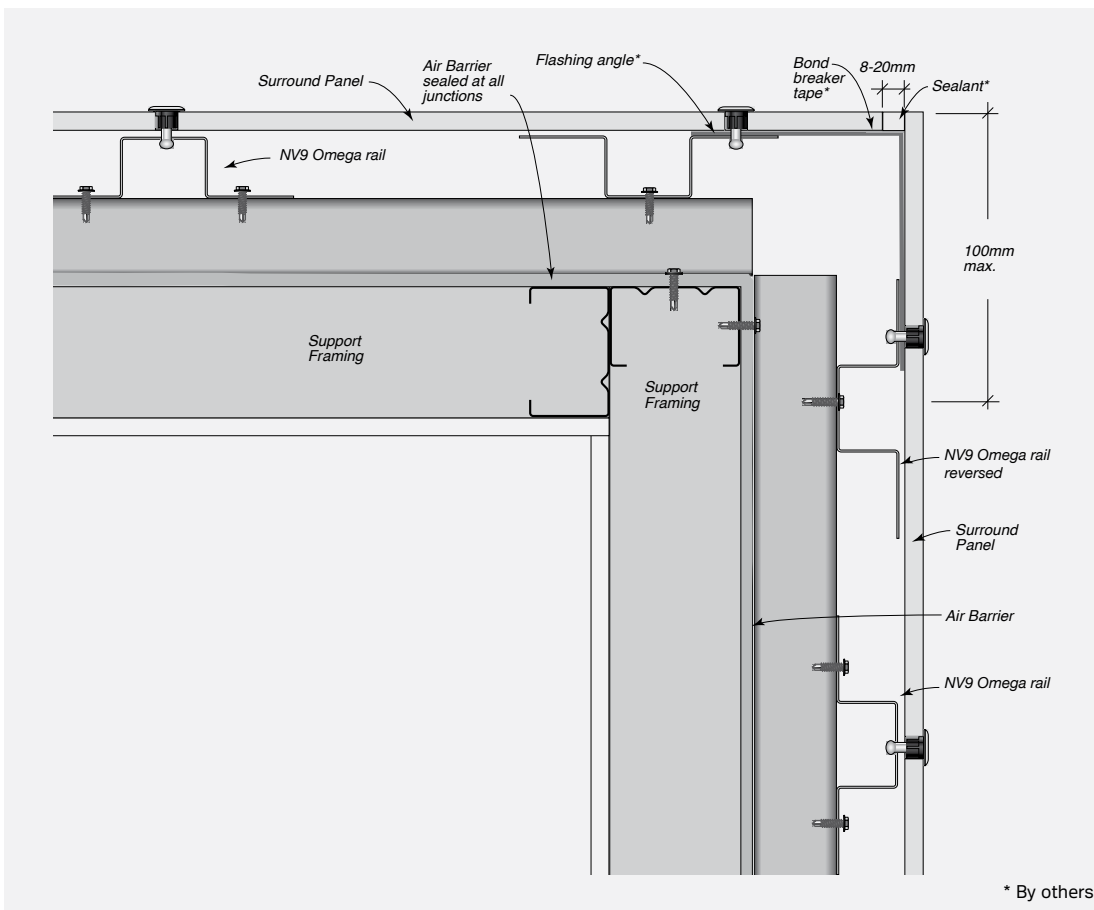

FIGURE 8.33 External Corner – Sealant filled





**SAFETY, HANDLING
+ GENERAL CARE**

SAFETY, HANDLING + GENERAL CARE



Health, Safety and Personal Protection Equipment (PPE)

Panels contain silicas that are harmful if inhaled. Protective clothing and breathing equipment must be worn when cutting products.

When cutting, drilling or grinding Surround panels using power tools, always ensure the work area is properly ventilated. An approved dust mask (AS/NZS

1715 and AS/NZS 1716) and safety glass (AS/NZS 1337) must be worn. Cemintel recommends that hearing protection also be worn.

Safety Data Sheet information is available at stateofclad.co.nz

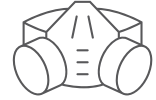

Recommended Safe Working Practices

Cutting Outdoors	<ol style="list-style-type: none"> 1. Position cutting station so wind will blow dust away from the user or others in the working area. 2. Use a dust reducing plunge saw equipped with a dust extraction system.
Sanding/Drilling/Other Machining	When sanding, drilling or machining, you should always wear a P1 or P2 dust mask and warn others in the immediate area.
Important Reminders	<ol style="list-style-type: none"> 1. NEVER use a power saw indoors. 2. NEVER use a saw blade that is not purpose-made for cutting fibre cement products. 3. NEVER dry sweep. 4. ALWAYS follow tool manufacturers' safety recommendations. 5. ALWAYS maintain tools in a clean condition.

Handling & General Care

Storage

All Surround panels must be stacked flat, clear of the ground and supported at 300mm maximum centres on a level platform. Panels must be kept dry, preferably stored inside the building. Panels must be dry prior to fixing, hence if it is necessary to store outside, the product must be protected from the weather.

Handling

Surround panels are prefinished products and must be treated with care during handling so as to avoid damage to edges, ends and prefinished surface. Panels should be carried horizontally on edge by at least two people.

As Surround external is a prefinished product, consideration should be given to the activity of other tradespeople. It is highly recommended that installation of Surround should always be held off until all other claddings have been completed so as to avoid damage.

Cutting

Panels should be cut from the back using a power saw. Cemintel recommends using the Makita Plunge Cut Saw with guide rail and appropriate blade, together with the appropriate dust extraction system.

All exposed cut edges **MUST BE SEALED TO PREVENT MOISTURE ABSORPTION**. Refer to 'Components' table for appropriate materials.

Mitres

It is not recommended to mitre panels as this can cause delamination of the face.

Penetrations

Penetrations in panels may be cut or drilled prior to installation. Cut from the back or drill from the front. Cut penetrations oversize by 8-10mm all around. Mask, prime and fill gaps with sealant in accordance with recommended methods and products.

Bevelled Edges

The top edge of panels at window sill level may require bevelling.

10
WARRANTY, CLEANING
+ MAINTENANCE

Warranty

The Cemintel Surround External panels have a product warranty of 15 years.

The full product warranty is available for download at stateofclad.co.nz

Wash Down Process

Panels have been coated with a factory finish. Consequently, where sufficiently exposed, rain can perform a natural wash down of the wall and ongoing maintenance should be limited to occasional rinse down or using a soft cloth or soft brush (like a dust pan brush).

Walls which are protected by soffits above must be washed down twice per year to remove salt and debris build up particularly at joints.

When cleaning the panels the following is recommended –

- Normal dirt can be removed with a soft brush and warm water up to 50 degrees celsius, to which a small amount of dishwashing liquid or soap has been added. The panels should be rinsed with clear water before they dry.
- Calcifications should be removed with a 5% sulfamic acid solution or with a commercial lime remover. The façade should be rinsed with clear water after cleaning.
- Panels discoloured by algal growth should be treated with an algicide without bleaching agents. This application should be allowed to take effect for several days. Afterwards, clean the panels using the 'normal dirt' procedure above.
- When rinsing down panels, use no more than 700 psi (50kh/cm²) of water pressure at a minimum of 3m distance from the face of the wall. Water pressure should be applied downward to avoid forcing water into joints.
- Use neutral detergent with a soft cloth or soft brush when removing dirty spots from a panel. When diluting the neutral detergent, follow the manufacturer's instructions and use the weakest solution possible.

Inspection, Repair and Maintenance

The durability of the Cemintel Surround range can be enhanced by periodic inspection and maintenance. Inspections should include examination of the coatings, flashings and seals. Any cracked or damaged finish or seals which would allow water ingress must be repaired immediately by resealing the affected area, or by removing the panel and replacing sealant. Any damaged flashings, sheets or sealant must be replaced as for new work.

Regularly inspect panel surfaces and follow wash-down procedures when required.

Ensure ventilation and drainage gaps between panels and flashings are clear of any debris.

It is recommended storing additional panels in case any panels are damaged in the future.



Cemintel Surround distributed exclusively in New Zealand by State of Clad

STATE OF CLAD

Our Offices

Auckland

956 Great South Road
Penrose, Auckland

Hamilton

59 Vickery Street
Te Rapa, Hamilton

Tauranga

15 Hynds Road
Greerton, Tauranga

Christchurch

1/99 Sawyers Arms Road
Papanui, Christchurch

stateofclad.co.nz
0800 333 404

For Design and Technical Support:
0800 667 887

Disclaimer: Information presented in this document is supplied in good faith and to the best of our knowledge, was accurate at the time of preparation. Products are subject to natural variation as part of the manufacturing process. Product images may vary from actual product in regard to colour and surface finish. The provision of this information should not be construed as a recommendation to use any of our products in violation of any patent rights or in breach of any statute or regulation. Users are advised to make their own determination as to the suitability of this information in relation to their particular purpose or specific circumstances. Since the information contained in this document may be applied under conditions beyond our control, no responsibility can be accepted by State of Clad, or its staff for any loss or damage caused by any person acting or refraining from action as a result of misuse of this information.