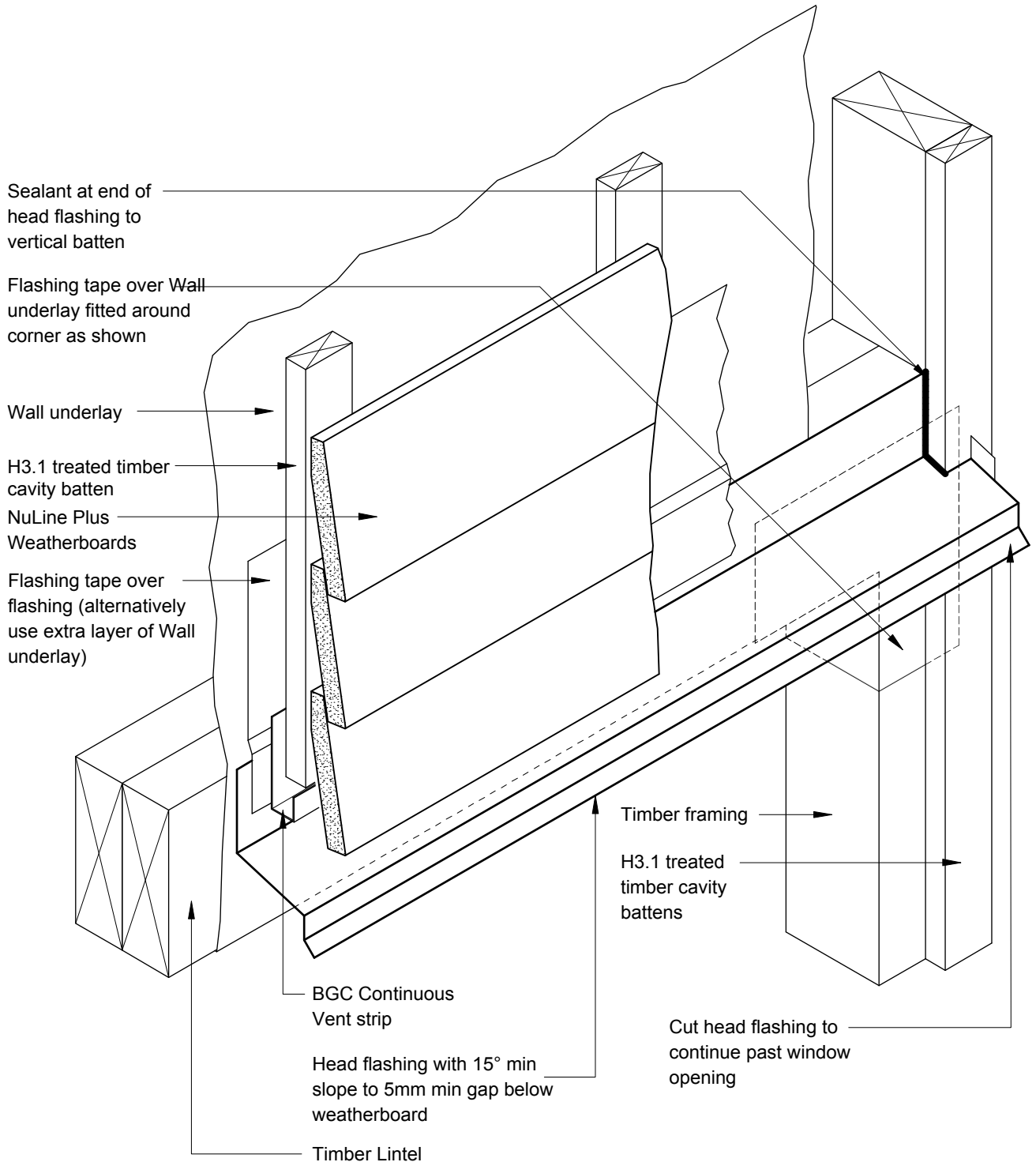

BGC**Fibre Cement**

PROFILE NuLine™ Plus Weatherboards

DATE Sep 2012

DETAIL Window Head/Jamb Junction
Detail Cavity Construction

SCALE 1:5 @ A4

DETAIL NO. NU-26