

# DESIGN WITH STEEL



## CONTENTS

Universal Beams	3	Coil	23
Universal Columns	5	Reinforcing Rounds and Mesh	24
Parallel Flange Channels	6	DuraGal Equal Angles	25
Joists – Taper Flange Beams	7	DuraGal Channels	30
Equal Angles	8	DuraGal Flats	31
Unequal Angles	11	Bolts – High Strength Friction Grip	33
Rectangular Hollow Sections	14	Purlins	34
DuraGal Rectangular Hollow Sections	16	Roofing	36
Square Hollow Sections	18	Standards	38
DuraGal Square Hollow Sections	20	Indent Service	38
Linepipe	21	Steel & Tube Publications	39
Plate	22		

**Please Note:** Pages 16, 17 & 20 – Product brand name change: ‘SupaGal’ is now ‘DuraGal’.

## INTRODUCTION

Steel & Tube is pleased to provide this *Design with Steel – Dimensions & Properties Handbook* for your use. We aim to carry all popular products and sizes on a continuous basis. The *Design with Steel – Dimensions & Properties Handbook* generally lists those sizes we carry ex-stock. However, there are some sizes (noted with a ♦) we offer on an indent basis only.

We also carry many products not featured in this particular publication. Please contact Steel & Tube for more information on our comprehensive range of steel products, or visit our website: [www.steelandtube.co.nz](http://www.steelandtube.co.nz).

### TELARC LIMITED/ISO 9001

Steel & Tube is committed to providing our customers with consistent and reliable service that meets their needs and promotes excellence in systems and a continuous improvement in quality. To demonstrate this commitment Steel & Tube is a Telarc registered supplier, certified to ISO 9001.

Telarc Limited ([www.telarc.co.nz](http://www.telarc.co.nz)) is a national technical authority responsible for quality system certification through independent assessment, audit and testing of quality control procedures.

In practical terms, Telarc’s role is to formally recognise all aspects of:

- quality in processing, distribution and service
- compliance with product or system specifications or standards
- technical competence of testing or inspecting
- quality of service performance and delivery

This role is to be carried out in a manner sufficient to provide consumers with confidence in the quality of products and services.



0800 478 335  
[www.steelandtube.co.nz](http://www.steelandtube.co.nz)

# UNIVERSAL BEAMS

**DIMENSIONS AND PROPERTIES**  
**AS/NZS 3679.1-300**  
**AS/NZS 3679.1-300 SO (SEISMIC)**

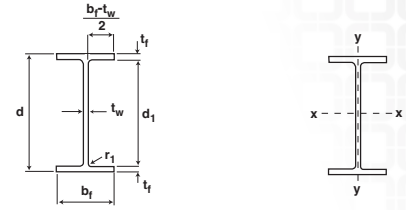

## 300PLUS

Designation	Mass per metre	Depth of section	Flange width	Flange thickness	Web thickness	Root radii	Depth between flanges	$d_1$	$(b_f \cdot t_w)$	Gross area of cross section	About x-axis				About y-axis				Torsion constant	Warping constant
											$I_x$	$Z_x$	$S_x$	$r_x$	$I_y$	$Z_y$	$S_y$	$r_y$		
	kg/m	mm	mm	mm	mm	mm	mm	mm	mm <sup>2</sup>	10 <sup>6</sup> mm <sup>4</sup>	10 <sup>3</sup> mm <sup>3</sup>	10 <sup>3</sup> mm <sup>3</sup>	mm	10 <sup>6</sup> mm <sup>4</sup>	10 <sup>3</sup> mm <sup>3</sup>	10 <sup>3</sup> mm <sup>3</sup>	mm	10 <sup>6</sup> mm <sup>4</sup>	10 <sup>6</sup> mm <sup>4</sup>	
▲ 610UB	125.0	612	229	19.6	11.9	14.0	572	48.1	5.54	16000	986.00	3230	3680	249.0	39.300	343.0	536.0	49.6	1560.0	3450.00
▲ 610UB	113.0	607	228	17.3	11.2	14.0	572	51.1	6.27	14500	875.00	2880	3290	246.0	34.300	300.0	469.0	48.7	1140.0	2980.00
▲ 610UB	101.0	602	228	14.8	10.6	14.0	572	54	7.34	13000	761.00	2530	2900	242.0	29.300	257.0	402.0	47.5	790.0	2530.00
▲ 530UB	92.4	533	209	15.6	10.2	14.0	502	49.2	6.37	11800	554.00	2080	2370	217.0	23.800	228.0	355.0	44.9	775.0	1590.00
▲ 530UB	82.0	528	209	13.2	9.6	14.0	502	52.3	7.55	10500	477.00	1810	2070	213.0	20.100	193.0	301.0	43.8	526.0	1330.00
▲ 460UB	82.1	460	191	16.0	9.9	11.4	428	43.3	5.66	10500	372.00	1610	1840	188.0	18.600	195.0	303.0	42.2	701.0	919.00
▲ 460UB	74.6	457	190	14.5	9.1	11.4	428	47.1	6.24	9520	335.00	1460	1660	188.0	16.600	175.0	271.0	41.8	530.0	815.00
▲ 460UB	67.1	454	190	12.7	8.5	11.4	428	50.4	7.15	8580	296.00	1300	1480	186.0	14.500	153.0	238.0	41.2	378.0	708.00
▲ 410UB	59.7	406	178	12.8	7.8	11.4	381	48.8	6.65	7640	216.00	1060	1200	168.0	12.100	135.0	209.0	39.7	337.0	467.00
▲ 410UB	53.7	403	178	10.9	7.6	11.4	381	50.1	7.82	6890	188.00	933	1060	165.0	10.300	115.0	179.0	38.6	234.0	394.00
▲ 360UB	56.7	359	172	13.0	8.0	11.4	333	41.6	6.31	7240	161.00	899	1010	149.0	11.000	128.0	198.0	39.0	338.0	330.00
▲ 360UB	50.7	356	171	11.5	7.3	11.4	333	45.6	7.12	6470	142.00	798	897	148.0	9.600	112.0	173.0	38.5	241.0	284.00
▲ 360UB	44.7	352	171	9.7	6.9	11.4	333	48.2	8.46	5720	121.00	689	777	146.0	8.100	94.7	146.0	37.6	161.0	237.00
310UB	46.2	307	166	11.8	6.7	11.4	284	42.3	6.75	5930	100.00	651	729	130.0	9.01	109.0	166.0	39.0	233.0	197.00
310UB	40.4	304	165	10.2	6.1	11.4	284	46.5	7.79	5210	86.40	569	633	129.0	7.650	92.7	142.0	38.3	157.0	165.00
310UB	32.0	298	149	8.0	5.5	13.0	282	51.3	8.97	4080	63.20	424	475	124.0	4.420	59.3	91.8	32.9	86.5	92.90
250UB	37.3	256	146	10.9	6.4	8.9	234	36.6	6.40	4750	55.70	435	486	108.0	5.660	77.5	119.0	34.5	158.0	85.20
250UB	31.4	252	146	8.6	6.1	8.9	234	38.4	8.13	4010	44.50	354	397	105.0	4.470	61.2	94.2	33.4	89.3	65.90
250UB	25.7	248	124	8.0	5.0	12.0	232	46.4	7.44	3270	35.4	285	319	104.0	2.550	41.1	63.6	27.9	67.4	36.7
200UB	29.8	207	134	9.6	6.3	8.9	188	29.8	6.65	3820	29.10	281	316	87.3	3.860	57.5	88.4	31.8	105.0	37.60
200UB	25.4	203	133	7.8	5.8	8.9	188	32.3	8.15	3230	23.60	232	260	85.4	3.060	46.1	70.9	30.8	62.7	29.20
200UB	22.3	202	133	7.0	5.0	8.9	188	37.5	9.14	2870	21.00	208	231	85.5	2.750	41.3	63.4	31.0	45.0	26.00
200UB	18.2	198	99	7.0	4.5	11.0	184	40.9	6.75	2320	15.80	160	180	82.6	1.140	23.0	35.7	22.1	38.6	10.40
180UB	22.2	179	90	10.0	6.0	8.9	159	26.5	4.20	2820	15.30	171	195	73.6	1.220	27.1	42.3	20.8	81.6	8.71
180UB	18.1	175	90	8.0	5.0	8.9	159	31.8	5.31	2300	12.10	139	157	72.6	0.975	21.7	33.7	20.6	44.8	6.80
180UB	16.1	173	90	7.0	4.5	8.9	159	35.3	6.11	2040	10.60	123	138	72.0	0.853	19.0	29.4	20.4	31.5	5.88
150UB	18.0	155	75	9.5	6.0	8.0	136	22.7	3.63	2300	9.05	117	135	62.8	0.672	17.9	28.2	17.1	60.5	3.56
150UB	14.0	150	75	7.0	5.0	8.0	136	27.2	5.00	1780	6.66	88.8	102	61.1	0.495	13.2	20.8	16.6	28.1	2.53

▲ New Zealand Design Standard NZS 3404 Clause 12.4.1.1 requires steel in seismic-resisting systems to comply with this range – Steel 300 SO.

# UNIVERSAL BEAMS

## PROPERTIES FOR DESIGN AS/NZS 3679.1-300 AS/NZS 3679.1-300 SO (SEISMIC)

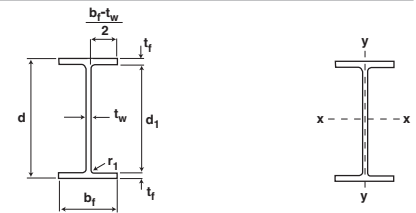

300PLUS					About x-axis		About y-axis		AS 3679.1-350					About x-axis		About y-axis	
Designation	Mass per metre kg/m	Flange $f_y$ MPa	Web $f_y$ MPa	Form factor $k_f$	Compactness	$Z_{ex}$ $10^3 \text{mm}^3$	Compactness	$Z_{ey}$ $10^3 \text{mm}^3$	Designation	Flange $f_y$ MPa	Web $f_y$ MPa	Form factor $k_f$	Compactness	$Z_{ex}$ $10^3 \text{mm}^3$	Compactness	$Z_{ey}$ $10^3 \text{mm}^3$	
▲ 610UB	125.0	280	300	0.950	C	3680	C	515.0	610UB	340	340	0.916	C	3680	C	515.0	
▲ 610UB	113.0	280	300	0.926	C	3290	C	451.0	610UB	340	340	0.891	C	3290	C	451.0	
▲ 610UB	101.0	300	320	0.888	C	2900	C	386.0	610UB	340	360	0.867	C	2900	C	386.0	
▲ 530UB	92.4	300	320	0.928	C	2370	C	342.0	530UB	340	360	0.907	C	2370	C	342.0	
▲ 530UB	82.0	300	320	0.902	C	2070	C	289.0	530UB	340	360	0.880	C	2070	C	289.0	
▲ 460UB	82.1	300	320	0.979	C	1840	C	292.0	460UB	340	360	0.956	C	1840	C	292.0	
▲ 460UB	74.6	300	320	0.948	C	1660	C	262.0	460UB	340	360	0.926	C	1660	C	262.0	
▲ 460UB	67.1	300	320	0.922	C	1480	C	230.0	460UB	340	360	0.901	C	1480	C	230.0	
▲ 410UB	59.7	300	320	0.938	C	1200	C	203.0	410UB	340	360	0.918	C	1200	C	203.0	
▲ 410UB	53.7	320	320	0.913	C	1060	C	173.0	410UB	360	360	0.894	N	1050	N	172.0	
▲ 360UB	56.7	300	320	0.996	C	1010	C	193.0	360UB	340	360	0.974	C	1010	C	193.0	
▲ 360UB	50.7	300	320	0.963	C	897	C	168.0	360UB	340	360	0.943	C	897	C	168.0	
▲ 360UB	44.7	320	320	0.930	N	770	N	140.0	360UB	360	360	0.911	N	762	N	139.0	
310UB	46.2	300	320	0.991	C	729	C	163.0	310UB	340	360	0.972	C	729	C	163.0	
310UB	40.4	320	320	0.952	C	633	C	139.0	310UB	360	360	0.936	N	629	N	138.0	
310UB	32.0	320	320	0.915	N	467	N	86.9	310UB	360	360	0.898	N	462	N	85.7	
250UB	37.3	320	320	1.000	C	486	C	116.0	250UB	360	360	1.000	C	486	C	116.0	
250UB	31.4	320	320	1.000	N	395	N	91.4	250UB	360	360	0.991	N	392	N	90.3	
250UB	25.7	320	320	0.949	C	319	C	61.7	250UB	360	360	0.932	C	319	C	61.7	
200UB	29.8	320	320	1.000	C	316	C	86.3	200UB	360	360	1.000	C	316	C	86.3	
200UB	25.4	320	320	1.000	N	259	N	68.8	200UB	360	360	1.000	N	257	N	68.0	
200UB	22.3	320	320	1.000	N	227	N	60.3	200UB	360	360	1.000	N	225	N	59.4	
200UB	18.2	320	320	0.990	C	180	C	34.4	200UB	360	360	0.970	C	180	C	34.4	
180UB	22.2	320	320	1.000	C	195	C	40.7	180UB	360	360	1.000	C	195	C	40.7	
180UB	18.1	320	320	1.000	C	157	C	32.5	180UB	360	360	1.000	C	157	C	32.5	
180UB	16.1	320	320	1.000	C	138	C	28.4	180UB	360	360	1.000	C	138	C	28.4	
150UB	18.0	320	320	1.000	C	135	C	26.9	150UB	360	360	1.000	C	135	C	26.9	
150UB	14.0	320	320	1.000	C	102	C	19.8	150UB	360	360	1.000	C	102	C	19.8	

▲ New Zealand Design Standard NZS 3404 Clause 12.4.1.1 requires steel in seismic-resisting systems to comply with this range – Steel 300 SO.

### Notes:

1. For 300PLUS sections the tensile strength ( $f_u$ ) is 440 MPa.
2. For grade 350 sections the tensile strength ( $f_u$ ) is 480 MPa.
3. C = compact section; N = non-compact section; S = slender section.
4. 300PLUS hot-rolled sections are produced to exceed the minimum requirements of AS/NZS 3679.1-300.
5. 300PLUS replaced grade 250 as the base grade for these sections in 1994.

# UNIVERSAL COLUMNS

## DIMENSIONS AND PROPERTIES AS/NZS 3679.1-300 AS/NZS 3679.1-300 SO (SEISMIC)

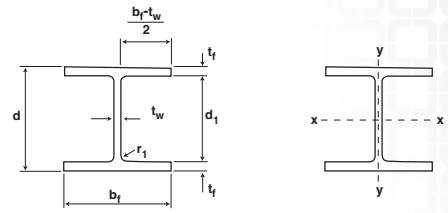

### 300PLUS

Designation	Mass per metre kg/m	Depth of section d mm	Flange width b <sub>f</sub> mm	Flange thickness t <sub>f</sub> mm	Web thickness t <sub>w</sub> mm	Root radii r <sub>1</sub> mm	Depth between flanges d <sub>1</sub> mm	d <sub>1</sub> t <sub>w</sub>	(b <sub>f</sub> ·t <sub>w</sub> ) 2t <sub>f</sub>	Gross area of cross section A <sub>g</sub> mm <sup>2</sup>	About x-axis				About y-axis				Torsion constant J 10 <sup>6</sup> mm <sup>4</sup>	Warping constant I <sub>w</sub> 10 <sup>6</sup> mm <sup>4</sup>
											I <sub>x</sub> 10 <sup>6</sup> mm <sup>4</sup>	Z <sub>x</sub> 10 <sup>3</sup> mm <sup>3</sup>	S <sub>x</sub> 10 <sup>3</sup> mm <sup>3</sup>	r <sub>x</sub> mm	I <sub>y</sub> 10 <sup>6</sup> mm <sup>4</sup>	Z <sub>y</sub> 10 <sup>3</sup> mm <sup>3</sup>	S <sub>y</sub> 10 <sup>3</sup> mm <sup>3</sup>	r <sub>y</sub> mm		
▲ 310UC	158.0	327	311	25.0	15.7	16.5	277	17.7	5.91	20100	388.00	2370.0	2680.0	139.0	125.00	807.0	1230.0	78.9	3810.0	2860.0
▲ 310UC	137.0	321	309	21.7	13.8	16.5	277	20.1	6.80	17500	329.00	2050.0	2300.0	137.0	107.00	691.0	1050.0	78.2	2520.0	2390.0
▲ 310UC	118.0	315	307	18.7	11.9	16.5	277	23.3	7.89	15000	277.00	1760.0	1960.0	136.0	90.20	588.0	893.0	77.5	1630.0	1980.0
▲ 310UC	96.8	308	305	15.4	9.9	16.5	277	28.0	9.58	12400	223.00	1450.0	1600.0	134.0	72.90	478.0	725.0	76.7	928.0	1560.0
▲ 250UC	89.5	260	256	17.3	10.5	14.0	225	21.5	7.10	11400	143.00	1100.0	1230.0	112.0	48.40	378.0	575.0	65.2	1040.0	713.0
▲ 250UC	72.9	254	254	14.2	8.6	14.0	225	26.2	8.64	9320	114.00	897.0	992.0	111.0	38.80	306.0	463.0	64.5	586.0	557.0
▲ 200UC	59.5	210	205	14.2	9.3	11.4	181	19.5	6.89	7620	61.30	584.0	656.0	89.7	20.40	199.0	303.0	51.7	477.0	195.0
▲ 200UC	52.2	206	204	12.5	8.0	11.4	181	22.7	7.84	6660	52.80	512.0	570.0	89.1	17.70	174.0	264.0	51.5	325.0	166.0
▲ 200UC	46.2	203	203	11.0	7.3	11.4	181	24.8	8.90	5900	45.90	451.0	500.0	88.2	15.30	151.0	230.0	51.0	228.0	142.0
150UC	37.2	162	154	11.5	8.1	8.9	139	17.1	6.34	4730	22.20	274.0	310.0	68.4	7.01	91.0	139.0	38.5	197.0	39.6
150UC	30.0	158	153	9.4	6.6	8.9	139	21.0	7.79	3860	17.60	223.0	250.0	67.5	5.62	73.4	112.0	38.1	109.0	30.8
150UC	23.4	152	152	6.8	6.1	8.9	139	22.8	10.70	2980	12.60	166.0	184.0	65.1	3.98	52.4	80.2	36.6	50.2	21.1
100UC	14.8	97	99	7.0	5.0	10.0	83	16.6	6.71	1890	3.18	65.6	74.4	41.1	1.14	22.9	35.2	24.5	34.9	2.3

▲ New Zealand Design Standard NZS 3404 Clause 12.4.1.1 requires steel in seismic-resisting systems to comply with this range – Steel 300 SO.

# UNIVERSAL COLUMNS

## PROPERTIES FOR DESIGN AS/NZS 3679.1-300 AS/NZS 3679.1-300 SO (SEISMIC)

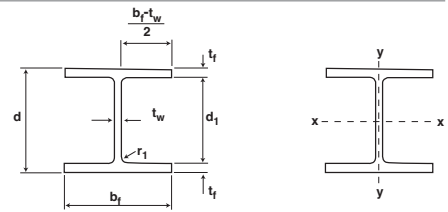

### 300PLUS

Designation	Mass per metre kg/m	Flange f <sub>y</sub> MPa	Web f <sub>y</sub> MPa	Form factor k <sub>f</sub>	About x-axis		About y-axis		AS 3679.1-350				About x-axis		About y-axis	
					Compactness	Z <sub>ex</sub> 10 <sup>3</sup> mm <sup>3</sup>	Compactness	Z <sub>ey</sub> 10 <sup>3</sup> mm <sup>3</sup>	Designation	Flange f <sub>y</sub> MPa	Web f <sub>y</sub> MPa	Form factor k <sub>f</sub>	Compactness	Z <sub>ex</sub> 10 <sup>3</sup> mm <sup>3</sup>	Compactness	Z <sub>ey</sub> 10 <sup>3</sup> mm <sup>3</sup>
▲ 310UC	158.0	280	300	1	C	2680.0	C	1210.0	310UC	340	340	1	C	2680.0	C	1210.0
▲ 310UC	137.0	280	300	1	C	2300.0	C	1040.0	310UC	340	340	1	C	2300.0	C	1040.0
▲ 310UC	118.0	280	300	1	C	1960.0	C	882.0	310UC	340	340	1	N	1950.0	N	878.0
▲ 310UC	96.8	300	320	1	N	1560.0	N	694.0	310UC	340	360	1	N	1550.0	N	684.0
▲ 250UC	89.5	280	320	1	C	1230.0	C	567.0	250UC	340	360	1	C	1230.0	C	567.0
▲ 250UC	72.9	300	320	1	N	986.0	N	454.0	250UC	340	360	1	N	977.0	N	448.0
▲ 200UC	59.5	300	320	1	C	656.0	C	299.0	200UC	340	360	1	C	656.0	C	299.0
▲ 200UC	52.2	300	320	1	C	570.0	C	260.0	200UC	340	360	1	N	569.0	N	260.0
▲ 200UC	46.2	300	320	1	N	494.0	N	223.0	200UC	340	360	1	N	490.0	N	220.0
150UC	37.2	300	320	1	C	310.0	C	137.0	150UC	340	360	1	C	310.0	C	137.0
150UC	30.0	320	320	1	C	250.0	C	110.0	150UC	360	360	1	N	248.0	N	109.0
150UC	23.4	320	320	1	N	176.0	N	73.5	150UC	360	360	1	N	174.0	N	72.3
100UC	14.8	320	320	1	C	74.4	C	34.4	100UC	360	360	1	C	74.4	C	34.4

▲ New Zealand Design Standard NZS 3404 Clause 12.4.1.1 requires steel in seismic-resisting systems to comply with this range – Steel 300 SO.

#### Notes:

- For 300PLUS sections the tensile strength (f<sub>t</sub>) is 440 MPa.
- For grade 350 sections the tensile strength (f<sub>t</sub>) is 480 MPa.
- C = compact section; N = non-compact section; S = slender section.
- 300PLUS hot-rolled sections are produced to exceed the minimum requirements of AS/NZS 3679.1-300.
- 300PLUS replaced grade 250 as the base grade for these sections in 1994.

# PARALLEL FLANGE CHANNELS

## DIMENSIONS AND PROPERTIES AS/NZS 3679.1-300

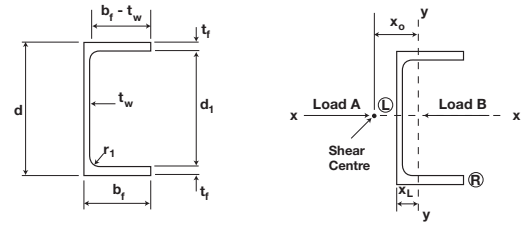

### 300PLUS

Designation	Mass per metre kg/m	Depth of section d	Flange width b <sub>f</sub>	Flange thickness t <sub>f</sub>	Web thickness t <sub>w</sub>	Root radii r <sub>1</sub>	Depth between flanges d <sub>1</sub>	d <sub>1</sub>	(b <sub>f</sub> -t <sub>w</sub> )	Gross area of cross section A <sub>g</sub>	Coordinate of centroid X <sub>L</sub>	Coordinate of shear centre X <sub>0</sub>	About x-axis				About y-axis				Torsion constant J	Warping constant I <sub>w</sub>	
													I <sub>x</sub>	Z <sub>x</sub>	S <sub>x</sub>	r <sub>x</sub>	I <sub>y</sub>	Z <sub>yR</sub>	Z <sub>yL</sub>	S <sub>y</sub>			r <sub>y</sub>
380 x 100 PFC	55.2	380	100	17.5	10.0	14	345	34.5	5.14	7030	27.5	56.7	152	798	946	1470	6.48	89.4	236.0	161.0	30.4	472.0	151.00
300 x 90 PFC	40.1	300	90	16.0	8.0	14	268	33.5	5.13	5110	27.2	56.1	72.4	483	564	1190	4.04	64.4	148.0	117.0	28.1	290.0	58.20
250 x 90 PFC	35.5	250	90	15.0	8.0	12	220	27.5	5.47	4520	28.6	58.5	45.1	361	421	99.9	3.64	59.3	127.0	107.0	28.4	238.0	35.90
230 x 75 PFC	25.1	230	75	12.0	6.5	12	206	31.7	5.71	3200	22.6	46.7	26.8	233	271	91.4	1.76	33.6	77.8	61.0	23.5	108.0	15.00
200 x 75 PFC	22.9	200	75	12.0	6.0	12	176	29.3	5.75	2920	24.4	50.5	19.1	191	221	80.9	1.65	32.7	67.8	58.9	23.8	101.0	10.60
180 x 75 PFC	20.9	180	75	11.0	6.0	12	158	26.3	6.27	2660	24.5	50.3	14.1	157	182	72.9	1.51	29.9	61.5	53.8	23.8	81.4	7.82
150 x 75 PFC	17.7	150	75	9.5	6.0	10	131	21.8	7.26	2250	24.9	51.0	8.34	111	129	60.8	1.29	25.7	51.6	46.0	23.9	54.9	4.59
125 x 65 PFC	11.9	125	65	7.5	4.7	8	110	23.4	8.04	1520	21.8	45.0	3.97	63.5	73	51.1	0.658	15.2	30.2	27.2	20.8	23.1	1.64
100 x 50 PFC	8.31	100	50	6.7	4.2	8	86.6	20.6	6.84	1060	16.7	33.9	1.74	34.7	40.3	40.4	0.267	8.01	16.0	14.4	15.9	13.2	0.424
75 x 40 PFC	5.92	75	40	6.1	3.8	8	62.8	16.5	5.94	754	13.7	27.2	0.683	18.2	21.4	30.1	0.12	4.56	8.71	8.2	12.6	8.13	0.106

# PARALLEL FLANGE CHANNELS

## PROPERTIES FOR ASSESSING SECTION CAPACITY AS/NZS 3679.1-300

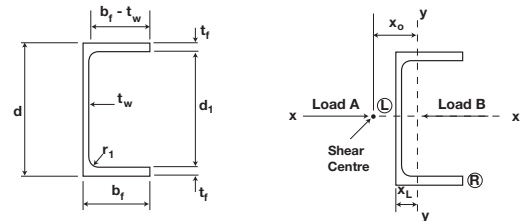

### 300PLUS

Designation	Flange f <sub>y</sub> MPa	Web f <sub>y</sub> MPa	Form factor k <sub>f</sub>	About x-axis			About y-axis			Designation	Flange f <sub>y</sub> MPa	Web f <sub>y</sub> MPa	Form factor k <sub>f</sub>	About x-axis			About y-axis		
				Z <sub>ex</sub> 10 <sup>3</sup> mm <sup>3</sup>	Load A Z <sub>ey</sub> 10 <sup>3</sup> mm <sup>3</sup>	Load B Z <sub>ey</sub> 10 <sup>3</sup> mm <sup>3</sup>	Z <sub>ex</sub> 10 <sup>3</sup> mm <sup>3</sup>	Load A Z <sub>ey</sub> 10 <sup>3</sup> mm <sup>3</sup>	Load B Z <sub>ey</sub> 10 <sup>3</sup> mm <sup>3</sup>					Z <sub>ex</sub> 10 <sup>3</sup> mm <sup>3</sup>	Load A Z <sub>ey</sub> 10 <sup>3</sup> mm <sup>3</sup>	Load B Z <sub>ey</sub> 10 <sup>3</sup> mm <sup>3</sup>			
380 x 100 PFC	280	320	1	946	115	134	380PFC	340	360	1	946	104	134						
300 x 90 PFC	300	320	1	564	82.3	96.6	300PFC	340	360	1	564	77.2	96.6						
250 x 90 PFC	300	320	1	421	88.7	89.0	250PFC	340	360	1	421	84.9	89.0						
230 x 75 PFC	300	320	1	271	45.1	50.4	230PFC	340	360	1	271	42.6	50.4						
200 x 75 PFC	300	320	1	221	46.7	49.1	200PFC	340	360	1	221	44.5	49.1						
180 x 75 PFC	300	320	1	182	44.8	44.8	180PFC	340	360	1	182	44.1	44.8						
150 x 75 PFC	320	320	1	129	38.5	38.5	150PFC	360	360	1	129	38.5	38.5						
125 x 65 PFC	320	320	1	72.8	22.8	22.8	125PFC	360	360	1	72	22.5	22.8						
100 x 50 PFC	320	320	1	40.3	12.0	12.0	100PFC	360	360	1	40.3	12.0	12.0						
75 x 40 PFC	320	320	1	21.4	6.84	6.84	75PFC	360	360	1	21.4	6.84	6.84						

### Notes:

- For 300PLUS sections the tensile strength (f<sub>t</sub>) is 440 MPa.
- For grade 350 sections the tensile strength (f<sub>t</sub>) is 480 MPa.
- 300PLUS hot-rolled sections are produced to exceed the minimum requirements of AS/NZS 3679.1-300.
- 300PLUS replaced grade 250 as the base grade for these sections in 1994.

# JOISTS – TAPER FLANGE BEAMS

## DIMENSIONS AND PROPERTIES AS/NZS 3679

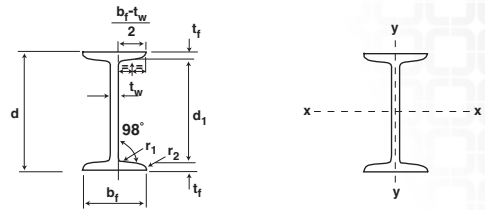

### 300PLUS

Designation	Mass per metre	Depth of section	Flange width	Flange thickness	Web thickness	Root radii	Toe radii	Depth between flanges	$d_1$	$(b_f - t_w)$	Gross area of cross section	About x-axis				About y-axis				Torsion constant	Warping constant
												$I_x$	$Z_x$	$S_x$	$r_x$	$I_y$	$Z_y$	$S_y$	$r_y$		
	kg/m	mm	mm	mm	mm	mm	mm	mm	mm	mm	mm <sup>2</sup>	10 <sup>6</sup> mm <sup>4</sup>	10 <sup>3</sup> mm <sup>3</sup>	10 <sup>3</sup> mm <sup>3</sup>	mm	10 <sup>6</sup> mm <sup>4</sup>	10 <sup>3</sup> mm <sup>3</sup>	10 <sup>3</sup> mm <sup>3</sup>	mm	10 <sup>6</sup> mm <sup>4</sup>	10 <sup>9</sup> mm <sup>6</sup>
125 x 65 TFB	13.1	125	65	8.5	5.0	8.0	4.0	108	21.6	3.53	1670	4.34	69.4	80.3	50.9	0.337	10.4	17.2	14.2	40.2	1.14
100 x 45 TFB	7.2	100	45	6.0	4.0	7.0	3.0	88	22.0	3.42	917	1.46	29.2	34.1	39.9	0.0795	3.53	6.0	9.31	11.6	0.0176

## PROPERTIES FOR ASSESSING SECTION CAPACITY

### 300PLUS

Designation	Flange $f_y$	Web $f_y$	Form factor	About x-axis		About y-axis		AS 3679.1-350											
				Compactness	$Z_{ex}$	Compactness	$Z_{ey}$	Designation	Flange $f_y$	Web $f_y$	Form factor	About x-axis		About y-axis					
												Compactness	$Z_{ex}$	Compactness	$Z_{ey}$	Compactness	$Z_{ex}$	Compactness	$Z_{ey}$
	MPa	MPa	$k_f$		10 <sup>3</sup> mm <sup>3</sup>		10 <sup>3</sup> mm <sup>3</sup>		MPa	MPa	$k_f$		10 <sup>3</sup> mm <sup>3</sup>		10 <sup>3</sup> mm <sup>3</sup>		10 <sup>3</sup> mm <sup>3</sup>		10 <sup>3</sup> mm <sup>3</sup>
125 x 65 TFB	320	320	1	C	80.3	C	15.6	125 x 65 TFB	360	360	1	C	80.3	C	15.6				
100 x 45 TFB	320	320	1	C	34.1	C	5.3	100 x 45 TFB	360	360	1	C	34.1	C	5.3				

### Notes:

- For 300PLUS sections the tensile strength ( $f_U$ ) is 440 MPa.
- For grade 350 sections the tensile strength ( $f_U$ ) is 480 MPa.
- C = compact section; N = non-compact section; S = slender section.
- 300PLUS hot-rolled sections are produced to exceed the minimum requirements of AS/NZS 3679.1-300.
- 300PLUS replaced grade 250 as the base grade for these sections in 1994.

# EQUAL ANGLES

## X- AND Y-AXES DIMENSIONS AND PROPERTIES AS/NZS 3679.1-300

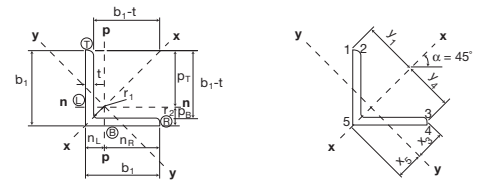

Designation Leg-size $b_1 \times b_1$	Nominal thick- ness	Mass per metre	Actual thick- ness	Radii		$(b_1-t)$ t	Gross area of cross- section $A_g$	Coordinate of centroid		About x-axis					About y-axis					Torsion constant $J$		
				Root $r_1$	Toe $r_2$			$n_L =$ $P_B$	$n_R =$ $P_T$	$I_x$	$I_y =$ $I_4$	$Z_{x1} =$ $Z_{x4}$	$S_x$	$r_x$	$I_y$	$x_3$	$Z_{y3}$	$x_5$	$Z_{y5}$		$S_y$	$r_y$
mm	mm	kg/m	mm	mm	mm	mm	mm <sup>2</sup>	mm	mm	10 <sup>6</sup> mm <sup>4</sup>	mm	10 <sup>3</sup> mm <sup>3</sup>	10 <sup>3</sup> mm <sup>3</sup>	mm	10 <sup>6</sup> mm <sup>4</sup>	mm	10 <sup>3</sup> mm <sup>3</sup>	mm	10 <sup>3</sup> mm <sup>3</sup>	10 <sup>3</sup> mm <sup>3</sup>	mm	10 <sup>3</sup> mm <sup>4</sup>
◆ 200x200 x 26 EA	76.8	26.0	18.0	5.0	6.69	9780	59.3	141	56.8	141	402	643	76.2	14.9	73.9	202	83.8	178	329	39.0	2250	
◆ 20 EA	60.1	20.0	18.0	5.0	9.00	7660	57.0	143	45.7	141	323	511	77.2	11.8	72.9	162	80.6	147	260	39.3	1060	
◆ 18 EA	54.4	18.0	18.0	5.0	10.1	6930	56.2	144	41.7	141	295	464	77.6	10.8	72.6	149	79.5	136	236	39.4	778	
◆ 16 EA	48.7	16.0	18.0	5.0	11.5	6200	55.4	145	37.6	141	266	417	77.9	9.72	72.3	135	78.4	124	212	39.6	554	
◆ 13 EA	40.0	13.0	18.0	5.0	14.4	5090	54.2	146	31.2	141	221	344	78.3	8.08	71.9	112	76.6	105	176	39.8	304	
◆ 150 x 150 x 19 EA	42.1	19.0	13.0	5.0	6.89	5360	44.2	106	17.6	106	166	265	57.2	4.60	54.9	83.8	62.6	73.5	135	29.3	657	
◆ 16 EA	35.4	15.8	13.0	5.0	8.49	4520	43.0	107	15.1	106	142	225	57.8	3.91	54.3	71.9	60.8	64.2	115	29.4	386	
◆ 12 EA	27.3	12.0	13.0	5.0	11.5	3480	41.5	108	11.9	106	112	175	58.4	3.06	53.7	56.9	58.7	52.1	89.3	29.6	174	
◆ 10 EA	21.9	9.5	13.0	5.0	14.8	2790	40.5	109	9.61	106	90.6	141	58.7	2.48	53.4	46.4	57.3	43.3	72.0	29.8	88.9	
◆ 125 x 125 x 16 EA	29.1	15.8	10.0	5.0	6.91	3710	36.8	88.2	8.43	88.4	95.4	153	47.7	2.20	45.4	48.5	52.1	42.3	77.8	24.4	313	
◆ 12 EA	22.5	12.0	10.0	5.0	9.42	2870	35.4	89.6	6.69	88.4	75.7	120	48.3	1.73	44.7	38.6	50.1	34.5	60.8	24.5	141	
◆ 10 EA	18.0	9.5	10.0	5.0	12.2	2300	34.4	90.6	5.44	88.4	61.6	96.5	48.7	1.40	44.4	31.5	48.7	28.8	49.0	24.7	71.9	
◆ 8 EA	14.9	7.8	10.0	5.0	15.0	1900	33.7	91.3	4.55	88.4	51.5	80.2	48.9	1.17	44.2	26.5	47.7	24.5	40.8	24.8	40.6	
◆ 100 x 100 x 12 EA	17.7	12.0	8.0	5.0	7.33	2260	29.2	70.8	3.29	70.7	46.6	74.5	38.2	0.857	35.8	23.9	41.3	20.8	37.9	19.5	110	
◆ 10 EA	14.2	9.5	8.0	5.0	9.53	1810	28.2	71.8	2.70	70.7	38.2	60.4	38.6	0.695	35.4	19.6	39.9	17.4	30.7	19.6	56.2	
◆ 8 EA	11.8	7.8	8.0	5.0	11.8	1500	27.5	72.5	2.27	70.7	32.0	50.3	38.8	0.582	35.2	16.5	38.9	14.9	25.6	19.7	31.7	
◆ 6 EA	9.16	6.0	8.0	5.0	15.7	1170	26.8	73.2	1.78	70.7	25.2	39.3	39.1	0.458	35.0	13.1	37.9	12.1	20.0	19.8	14.8	
◆ 90 x 90 x 10 EA	12.7	9.5	8.0	5.0	8.47	1620	25.7	64.3	1.93	63.6	30.4	48.3	34.5	0.500	31.9	15.7	36.4	13.8	24.6	17.6	50.5	
◆ 8 EA	10.6	7.8	8.0	5.0	10.5	1350	25.0	65.0	1.63	63.6	25.6	40.4	34.8	0.419	31.7	13.2	35.4	11.8	20.5	17.6	28.6	
◆ 6 EA	8.22	6.0	8.0	5.0	14.0	1050	24.3	65.7	1.28	63.6	20.1	31.6	35.0	0.330	31.5	10.5	34.3	9.62	16.1	17.8	13.4	
◆ 75 x 75 x 10 EA	10.5	9.5	8.0	5.0	6.89	1340	22.0	53.0	1.08	53.0	20.4	32.8	28.4	0.282	26.6	10.6	31.1	9.09	16.8	14.5	41.9	
◆ 8 EA	8.73	7.8	8.0	5.0	8.62	1110	21.3	53.7	0.913	53.0	17.2	27.5	28.7	0.237	26.4	8.99	30.1	7.87	14.0	14.6	23.8	
◆ 6 EA	6.81	6.0	8.0	5.0	11.5	867	20.5	54.5	0.722	53.0	13.6	21.6	28.9	0.187	26.2	7.15	29.0	6.44	11.0	14.7	11.2	
◆ 5 EA	5.27	4.6	8.0	5.0	15.3	672	19.9	55.1	0.563	53.0	10.6	16.7	29.0	0.147	26.1	5.62	28.1	5.22	8.61	14.8	5.28	
◆ 65 x 65 x 10 EA	9.02	9.5	6.0	3.0	5.84	1150	19.6	45.4	0.691	46.0	15.0	24.3	24.5	0.183	23.7	7.71	27.7	6.60	12.5	12.6	35.1	
◆ 8 EA	7.51	7.8	6.0	3.0	7.33	957	19.0	46.0	0.589	46.0	12.8	20.5	24.8	0.154	23.4	6.56	26.8	5.73	10.5	12.7	20.0	
◆ 6 EA	5.87	6.0	6.0	3.0	9.83	748	18.3	46.7	0.471	46.0	10.2	16.2	25.1	0.122	23.1	5.26	25.8	4.71	8.25	12.8	9.37	
◆ 5 EA	4.56	4.6	6.0	3.0	13.1	581	17.7	47.3	0.371	46.0	8.08	12.7	25.3	0.0959	23.0	4.18	25.0	3.83	6.46	12.9	4.36	
◆ 55 x 55 x 6 EA	4.93	6.0	6.0	3.0	8.17	628	15.8	39.2	0.278	38.9	7.14	11.4	21.0	0.0723	19.6	3.69	22.3	3.24	5.82	10.7	7.93	
◆ 5 EA	3.84	4.6	6.0	3.0	11.0	489	15.2	39.8	0.220	38.9	5.66	8.93	21.2	0.0571	19.4	2.94	21.5	2.66	4.57	10.8	3.71	
◆ 50 x 50 x 8 EA	5.68	7.8	6.0	3.0	5.41	723	15.2	34.8	0.253	35.4	7.16	11.7	18.7	0.0675	18.1	3.73	21.5	3.14	6.00	9.66	15.2	
◆ 6 EA	4.46	6.0	6.0	3.0	7.33	568	14.5	35.5	0.205	35.4	5.79	9.30	19.0	0.0536	17.8	3.01	20.5	2.61	4.76	9.71	7.21	
◆ 5 EA	3.48	4.6	6.0	3.0	9.87	443	13.9	36.1	0.163	35.4	4.61	7.32	19.2	0.0424	17.6	2.40	19.7	2.15	3.75	9.78	3.38	
◆ 3 EA	2.31	3.0	6.0	3.0	15.7	295	13.2	36.8	0.110	35.4	3.11	4.90	19.3	0.0289	17.6	1.65	18.7	1.55	2.53	9.90	1.01	
◆ 45 x 45 x 6 EA	3.97	6.0	5.0	3.0	6.50	506	13.3	31.7	0.146	31.8	4.59	7.41	17.0	0.0383	16.0	2.39	18.8	2.04	3.79	8.71	6.32	
◆ 5 EA	3.10	4.6	5.0	3.0	8.78	394	12.7	32.3	0.117	31.8	3.66	5.84	17.2	0.0303	15.8	1.91	18.0	1.68	2.99	8.76	2.96	
◆ 3 EA	2.06	3.0	5.0	3.0	14.0	263	12.0	33.0	0.0790	31.8	2.48	3.92	17.3	0.0206	15.7	1.31	17.0	1.21	2.02	8.85	0.875	
◆ 40 x 40 x 6 EA	3.50	6.0	5.0	3.0	5.67	446	12.0	28.0	0.0997	28.3	3.53	5.75	15.0	0.0265	14.3	1.86	17.0	1.55	2.95	7.71	5.60	
◆ 5 EA	2.73	4.6	5.0	3.0	7.70	348	11.5	28.5	0.0801	28.3	2.83	4.55	15.2	0.0209	14.0	1.49	16.2	1.29	2.33	7.75	2.63	
◆ 3 EA	1.83	3.0	5.0	3.0	12.3	233	10.8	29.2	0.0545	28.3	1.93	3.06	15.3	0.0142	13.9	1.02	15.3	0.930	1.58	7.82	0.785	
◆ 30 x 30 x 6 EA	2.56	6.0	5.0	3.0	4.00	326	9.53	20.5	0.0387	21.2	1.83	3.06	10.9	0.0107	10.7	0.993	13.5	0.790	1.59	5.72	4.16	
◆ 5 EA	2.01	4.6	5.0	3.0	5.52	256	8.99	21.0	0.0316	21.2	1.49	2.45	11.1	0.00839	10.5	0.799	12.7	0.660	1.26	5.72	1.98	
◆ 3 EA	1.35	3.0	5.0	3.0	9.00	173	8.30	21.7	0.0218	21.2	1.03	1.67	11.2	0.00573	10.3	0.554	11.7	0.488	0.862	5.76	0.605	
◆ 25 x 25 x 6 EA	2.08	6.0	5.0	3.0	3.17	266	8.28	16.7	0.0210	17.7	1.19	2.03	8.89	0.00600	8.97	0.669	11.7	0.513	1.07	4.75	3.44	
◆ 5 EA	1.65	4.6	5.0	3.0	4.43	210	7.75	17.3	0.0173	17.7	0.980	1.65	9.07	0.00469	8.73	0.537	11.0	0.428	0.849	4.72	1.66	
◆ 3 EA	1.12	3.0	5.0	3.0	7.33	143	7.07	17.9	0.0121	17.7	0.685	1.13	9.22	0.00319	8.56	0.373	9.99	0.319	0.583	4.73	0.515	

◆ These items are not commonly stocked but are available on indent. A minimum order quantity may apply on some sizes.



# EQUAL ANGLES

## X- AND Y-AXES PROPERTIES FOR ASSESSING SECTION CAPACITY AS/NZS 3679.1-300

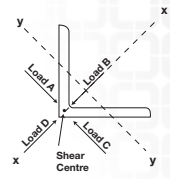

Designation	Yield stress $f_y$	Form factor $k_f$	About x-axis			About y-axis			Yield stress $f_y$	Form factor $k_f$	About x-axis			About y-axis			
			Load A or C $Z_{ex}$	Load B $Z_{ey}$	Load D $Z_{ey}$	Load A or C $Z_{ex}$	Load B $Z_{ey}$	Load D $Z_{ey}$			Load A or C $Z_{ex}$	Load B $Z_{ey}$	Load D $Z_{ey}$				
mm mm	MPa		$10^3\text{mm}^3$	$10^3\text{mm}^3$	$10^3\text{mm}^3$	MPa		$10^3\text{mm}^3$	$10^3\text{mm}^3$	$10^3\text{mm}^3$	MPa		$10^3\text{mm}^3$	$10^3\text{mm}^3$	$10^3\text{mm}^3$		
<b>300PLUS</b>						<b>AS/NZS 3679.1-350</b>											
◆ 200 x 200 x 26 EA	280	1.00	602	267	267	340	1.00	602	267	267	340	1.00	469	214	220		
◆ 20 EA	280	1.00	479	218	220	340	1.00	469	214	220	340	1.00	417	192	204		
◆ 18 EA	280	1.00	427	196	204	340	1.00	417	192	204	340	1.00	362	169	186		
16 EA	300	1.00	369	172	186	340	1.00	362	169	186	340	1.00	278	132	158		
13 EA	300	1.00	285	136	158	340	0.956	278	132	158	340	0.956	209	94.5	96.3		
◆ 150 x 150 x 19 EA	280	1.00	248	110	110	340	1.00	248	110	110	340	1.00	152	70.9	78.1		
16 EA	300	1.00	212	95.7	96.3	340	1.00	209	94.5	96.3	340	1.00	111	53.1	64.9		
12 EA	300	1.00	155	72.3	78.1	340	1.00	152	70.9	78.1	340	1.00	143	63.4	63.4		
10 EA	320	0.958	114	54.5	64.9	360	0.906	111	53.1	64.9	360	0.906	109	49.6	51.7		
◆ 125 x 125 x 16 EA	300	1.00	143	63.4	63.4	340	1.00	143	63.4	63.4	340	1.00	81.6	38.1	43.1		
12 EA	300	1.00	110	50.3	51.7	340	1.00	109	49.6	51.7	340	1.00	62.7	29.9	36.8		
10 EA	320	1.00	83.2	38.9	43.1	360	1.00	81.6	38.1	43.1	360	1.00	69.9	31.1	31.1		
8 EA	320	0.943	64.3	30.7	36.8	360	0.892	62.7	29.9	36.8	360	0.892	54.4	24.8	26.1		
100 x 100 x 12 EA	300	1.00	69.9	31.1	31.1	340	1.00	69.9	31.1	31.1	340	1.00	42.9	20.0	22.4		
10 EA	320	1.00	55.1	25.2	26.1	360	1.00	54.4	24.8	26.1	360	1.00	30.0	14.4	18.1		
8 EA	320	1.00	43.7	20.4	22.4	360	1.00	42.9	20.0	22.4	360	1.00	44.5	20.1	20.6		
6 EA	320	0.906	30.9	14.8	18.1	360	0.856	30.0	14.4	18.1	360	0.856	35.4	16.4	17.8		
90 x 90 x 10 EA	320	1.00	45.0	20.4	20.6	360	1.00	44.5	20.1	20.6	360	1.00	25.3	12.1	14.4		
8 EA	320	1.00	36.0	16.7	17.8	360	1.00	35.4	16.4	17.8	360	1.00	30.5	13.6	13.6		
6 EA	320	1.00	25.9	12.4	14.4	360	0.954	25.3	12.1	14.4	360	0.954	25.1	11.5	11.8		
75 x 75 x 10 EA	320	1.00	30.5	13.6	13.6	360	1.00	30.5	13.6	13.6	360	1.00	18.4	8.70	9.66		
8 EA	320	1.00	25.4	11.6	11.8	360	1.00	25.1	11.5	11.8	360	1.00	12.8	6.30	7.82		
6 EA	320	1.00	18.7	8.85	9.66	360	1.00	18.4	8.70	9.66	360	1.00	22.5	9.90	9.90		
5 EA	320	0.927	13.2	6.47	7.82	360	0.876	12.8	6.30	7.82	360	0.876	19.2	8.59	8.59		
65 x 65 x 10 EA	320	1.00	22.5	9.90	9.90	360	1.00	22.5	9.90	9.90	360	1.00	14.5	6.66	7.07		
8 EA	320	1.00	19.2	8.59	8.59	360	1.00	19.2	8.59	8.59	360	1.00	10.4	4.94	5.75		
6 EA	320	1.00	14.7	6.76	7.07	360	1.00	14.5	6.66	7.07	360	1.00	10.5	4.78	4.86		
5 EA	320	1.00	10.6	5.05	5.75	360	1.00	10.4	4.94	5.75	360	1.00	7.75	3.64	3.98		
◆ 55 x 55 x 6 EA	320	1.00	10.7	4.84	4.86	360	1.00	10.5	4.78	4.86	360	1.00	10.7	4.71	4.71		
◆ 5 EA	320	1.00	7.88	3.70	3.98	360	1.00	7.75	3.64	3.98	360	1.00	8.69	3.92	3.92		
50 x 50 x 8 EA	320	1.00	10.7	4.71	4.71	360	1.00	10.7	4.71	4.71	360	1.00	6.50	3.03	3.22		
6 EA	320	1.00	8.69	3.92	3.92	360	1.00	8.69	3.92	3.92	360	1.00	6.50	3.03	3.22		
5 EA	320	1.00	6.60	3.08	3.22	360	1.00	6.50	3.03	3.22	360	1.00	3.71	1.85	2.32		
3 EA	320	0.907	3.82	1.90	2.32	360	0.858	3.71	1.85	2.32	360	0.858	6.88	3.06	3.06		
◆ 45 x 45 x 6 EA	320	1.00	6.88	3.06	3.06	360	1.00	6.88	3.06	3.06	360	1.00	5.32	2.44	2.52		
5 EA	320	1.00	5.39	2.47	2.52	360	1.00	5.32	2.44	2.52	360	1.00	3.12	1.52	1.81		
3 EA	320	1.00	3.19	1.55	1.81	360	0.954	3.12	1.52	1.81	360	0.954	5.29	2.33	2.33		
◆ 40 x 40 x 6 EA	320	1.00	5.29	2.33	2.33	360	1.00	5.29	2.33	2.33	360	1.00	4.22	1.92	1.93		
5 EA	320	1.00	4.25	1.93	1.93	360	1.00	4.22	1.92	1.93	360	1.00	2.54	1.23	1.40		
3 EA	320	1.00	2.59	1.25	1.40	360	1.00	2.54	1.23	1.40	360	1.00	2.74	1.19	1.19		
◆ 30 x 30 x 6 EA	320	1.00	2.74	1.19	1.19	360	1.00	2.74	1.19	1.19	360	1.00	2.23	0.990	0.990		
5 EA	320	1.00	2.23	0.990	0.990	360	1.00	2.23	0.990	0.990	360	1.00	1.48	0.705	0.732		
3 EA	320	1.00	1.50	0.714	0.732	360	1.00	1.48	0.705	0.732	360	1.00	1.78	0.769	0.769		
◆ 25 x 25 x 6 EA	320	1.00	1.78	0.769	0.769	360	1.00	1.78	0.769	0.769	360	1.00	1.47	0.642	0.642		
5 EA	320	1.00	1.47	0.642	0.642	360	1.00	1.47	0.642	0.642	360	1.00	1.03	0.479	0.479		
3 EA	320	1.00	1.03	0.479	0.479	360	1.00	1.03	0.479	0.479	360	1.00	1.03	0.479	0.479		

◆ These items are not commonly stocked but are available on indent. A minimum order quantity may apply on some sizes.

### Notes:

1. For 300PLUS sections the tensile strength ( $f_t$ ) is 440 MPa.
2. For grade 350 sections the tensile strength ( $f_t$ ) is 480 MPa.
3. 300PLUS hot-rolled sections are produced to exceed the minimum requirements of AS/NZS 3679.1-300.
4. 300PLUS replaced grade 250 as the base grade for these sections in 1994.

# EQUAL ANGLES

## N- AND P-AXES DIMENSIONS AND PROPERTIES AS/NZS 3679.1-300

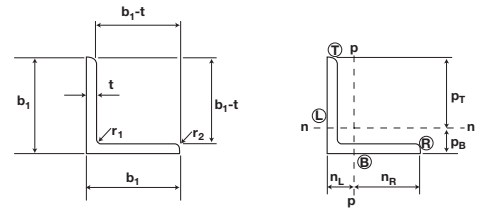

Designation	About n-axis and p-axis							Product of 2nd moment of area $I_{np}$
	$I_n=I_p$ $10^6\text{mm}^4$	$r_{L=PB}$ mm	$Z_{nB}=Z_{pL}$ $10^3\text{mm}^3$	$r_{R=PT}$ mm	$Z_{nT}=Z_{pR}$ $10^3\text{mm}^3$	$S_n=S_p$ $10^2\text{mm}^3$	$r_n=r_p$ mm	
mm mm mm								$10^6\text{mm}^4$
◆ 200 x 200 x 26 EA	35.8	59.3	605	141	255	460	60.5	-20.9
◆ 20 EA	28.8	57.0	505	143	201	363	61.3	-16.9
◆ 18 EA	26.3	56.2	467	144	183	330	61.5	-15.5
16 EA	23.7	55.4	427	145	164	296	61.8	-14.0
13 EA	19.7	54.2	363	146	135	243	62.2	-11.6
◆ 150 x 150 x 19 EA	11.1	44.2	250	106	105	189	45.4	-6.48
16 EA	9.48	43.0	220	107	88.7	160	45.8	-5.58
12 EA	7.46	41.5	180	108	68.8	124	46.3	-4.40
10 EA	6.04	40.5	149	109	55.2	99.9	46.6	-3.56
◆ 125 x 125 x 16 EA	5.32	36.8	144	88.2	60.3	109	37.9	-3.11
12 EA	4.21	35.4	119	89.6	47.0	85.0	38.3	-2.48
10 EA	3.42	34.4	99.4	90.6	37.8	68.4	38.6	-2.02
8 EA	2.86	33.7	84.9	91.3	31.3	56.8	38.8	-1.69
100 x 100 x 12 EA	2.08	29.2	71.1	70.8	29.3	53.2	30.3	-1.22
10 EA	1.70	28.2	60.1	71.8	23.6	42.9	30.6	-1.00
8 EA	1.42	27.5	51.7	72.5	19.6	35.7	30.8	-0.842
6 EA	1.12	26.8	41.8	73.2	15.3	27.8	31.0	-0.661
90 x 90 x 10 EA	1.22	25.7	47.3	64.3	18.9	34.4	27.4	-0.716
8 EA	1.02	25.0	40.9	65.0	15.7	28.7	27.6	-0.604
6 EA	0.805	24.3	33.2	65.7	12.3	22.4	27.7	-0.475
75 x 75 x 10 EA	0.681	22.0	31.0	53.0	12.8	23.4	22.6	-0.399
8 EA	0.575	21.3	27.0	53.7	10.7	19.6	22.7	-0.338
6 EA	0.455	20.5	22.1	54.5	8.35	15.3	22.9	-0.268
5 EA	0.355	19.9	17.9	55.1	6.44	11.8	23.0	-0.208
65 x 65 x 10 EA	0.437	19.6	22.3	45.4	9.62	17.4	19.5	-0.254
8 EA	0.371	19.0	19.6	46.0	8.07	14.6	19.7	-0.218
6 EA	0.296	18.3	16.2	46.7	6.34	11.5	19.9	-0.175
5 EA	0.234	17.7	13.2	47.3	4.94	8.97	20.1	-0.138
◆ 55 x 55 x 6 EA	0.175	15.8	11.1	39.2	4.46	8.11	16.7	-0.103
◆ 5 EA	0.139	15.2	9.12	39.8	3.48	6.34	16.8	-0.0814
50 x 50 x 8 EA	0.160	15.2	10.5	34.8	4.61	8.38	14.9	-0.0928
6 EA	0.129	14.5	8.90	35.5	3.64	6.63	15.1	-0.0756
5 EA	0.103	13.9	7.36	36.1	2.85	5.19	15.2	-0.0602
3 EA	0.0694	13.2	5.25	36.8	1.89	3.46	15.3	-0.0405
◆ 45 x 45 x 6 EA	0.0922	13.3	6.93	31.7	2.91	5.30	13.5	-0.0538
5 EA	0.0734	12.7	5.76	32.3	2.28	4.16	13.6	-0.0432
◆ 3 EA	0.0498	12.0	4.14	33.0	1.51	2.77	13.8	-0.0292
◆ 40 x 40 x 6 EA	0.0631	12.0	5.24	28.0	2.26	4.12	11.9	-0.0366
5 EA	0.0505	11.5	4.39	28.5	1.77	3.24	12.0	-0.0296
3 EA	0.0344	10.8	3.19	29.2	1.18	2.17	12.2	-0.0201
◆ 30 x 30 x 6 EA	0.0247	9.53	2.59	20.5	1.21	2.22	8.71	-0.0140
5 EA	0.0200	8.99	2.22	21.0	0.951	1.76	8.83	-0.0116
3 EA	0.0138	8.30	1.66	21.7	0.635	1.18	8.93	-0.00804
◆ 25 x 25 x 6 EA	0.0135	8.28	1.63	16.7	0.807	1.49	7.13	-0.00750
5 EA	0.0110	7.75	1.42	17.3	0.638	1.19	7.23	-0.00632
3 EA	0.00765	7.07	1.08	17.9	0.426	0.802	7.33	-0.00446

◆ These items are not commonly stocked but are available on indent. A minimum order quantity may apply on some sizes.

# UNEQUAL ANGLES

## X- AND Y-AXES DIMENSIONS AND PROPERTIES AS/NZS 3679.1-300

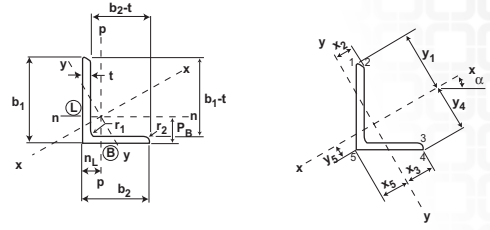

Designation Leg-size	Normal thickness	Mass per metre	Actual thick- ness	Radii		Gross area of cross section		Coordinate of centroid		About x-axis										About y-axis					Torsion con- stant	Tan alpha			
				Root	Toe	(b <sub>1</sub> -t)	(b <sub>2</sub> -t)	P <sub>B</sub>	n <sub>L</sub>	I <sub>x</sub>	Y <sub>1</sub>	Z <sub>x1</sub>	Y <sub>4</sub>	Z <sub>x4</sub>	Y <sub>5</sub>	Z <sub>x5</sub>	S <sub>x</sub>	r <sub>x</sub>	I <sub>y</sub>	x <sub>2</sub>	Z <sub>y2</sub>	x <sub>3</sub>	Z <sub>y3</sub>	x <sub>5</sub>			Z <sub>y5</sub>	S <sub>y</sub>	r <sub>y</sub>
b <sub>1</sub> x b <sub>2</sub>	t	r <sub>1</sub>	r <sub>2</sub>	t	t	A <sub>g</sub>	P <sub>B</sub>	n <sub>L</sub>	I <sub>x</sub>	Y <sub>1</sub>	Z <sub>x1</sub>	Y <sub>4</sub>	Z <sub>x4</sub>	Y <sub>5</sub>	Z <sub>x5</sub>	S <sub>x</sub>	r <sub>x</sub>	I <sub>y</sub>	x <sub>2</sub>	Z <sub>y2</sub>	x <sub>3</sub>	Z <sub>y3</sub>	x <sub>5</sub>	Z <sub>y5</sub>	S <sub>y</sub>	r <sub>y</sub>	J		
mm	mm	mm	kg/m	mm	mm	mm <sup>2</sup>	mm	mm	10 <sup>6</sup> mm <sup>4</sup>	mm	10 <sup>3</sup> mm <sup>3</sup>	mm	10 <sup>3</sup> mm <sup>3</sup>	mm	10 <sup>3</sup> mm <sup>3</sup>	mm	10 <sup>6</sup> mm <sup>4</sup>	mm	10 <sup>3</sup> mm <sup>3</sup>	mm	10 <sup>3</sup> mm <sup>3</sup>	mm	10 <sup>3</sup> mm <sup>3</sup>	mm	10 <sup>3</sup> mm <sup>3</sup>	mm	10 <sup>3</sup> mm <sup>4</sup>		
150 x 100 x 12 UA	22.5	12.0	10.0	5.0	11.5	7.33	2870	49.1	24.3	7.51	102	73.5	75.3	99.7	35.2	213	127	51.2	1.35	27.6	48.8	52.9	25.5	42.0	32.1	51.7	21.7	141	0.438
10 UA	18.0	9.5	10.0	5.0	14.8	9.53	2300	48.1	23.3	6.11	103	59.5	74.9	81.5	34.6	177	102	51.6	1.09	26.9	40.7	53.0	20.6	40.7	26.9	41.8	21.8	71.9	0.441
150 x 90 x 16 UA	27.9	15.8	10.0	5.0	8.49	4.70	3550	52.5	22.7	8.80	99.5	88.4	71.9	122	41.9	210	154	49.8	1.32	24.6	53.8	49.9	26.5	38.9	34.0	55.9	19.3	300	0.353
12 UA	21.6	12.0	10.0	5.0	11.5	6.50	2750	51.0	21.2	6.97	100	69.4	71.3	97.8	40.8	171	120	50.4	1.04	23.4	44.5	50.1	20.8	37.2	28.0	43.8	19.5	136	0.360
10 UA	17.3	9.5	10.0	5.0	14.8	8.47	2200	50.0	20.2	5.66	101	56.1	70.7	80.1	40.1	141	96.6	50.7	0.847	22.6	37.4	50.4	16.8	36.1	23.5	35.4	19.6	69.0	0.363
8 UA	14.3	7.8	10.0	5.0	18.2	10.5	1820	49.2	19.6	4.73	101	46.7	70.3	67.3	39.5	120	80.1	51.0	0.710	22.1	32.2	50.6	14.0	35.2	20.2	29.5	19.7	39.0	0.364
125 x 75 x 12 UA	17.7	12.0	8.0	5.0	9.42	5.25	2260	43.3	18.4	3.91	83.2	47.0	59.7	65.5	34.6	113	81.4	41.6	0.585	19.9	29.3	41.4	14.1	31.9	18.4	29.7	16.1	110	0.356
10 UA	14.2	9.5	8.0	5.0	12.2	6.89	1810	42.3	17.5	3.20	83.8	38.2	59.3	53.9	33.9	94.4	65.8	42.0	0.476	19.2	24.9	41.6	11.4	30.7	15.5	24.1	16.2	56.2	0.360
8 UA	11.8	7.8	8.0	5.0	15.0	8.62	1500	41.5	16.8	2.68	84.2	31.8	58.9	45.5	33.3	80.4	54.6	42.2	0.399	18.6	21.5	41.8	9.55	29.9	13.3	20.1	16.3	31.7	0.363
6 UA	9.16	6.0	8.0	5.0	19.8	11.5	1170	40.7	16.0	2.10	84.7	24.8	58.5	36.0	32.8	64.1	42.4	42.5	0.315	18.0	17.5	42.1	7.47	29.0	10.8	15.7	16.4	14.8	0.364
100 x 75 x 10 UA	12.4	9.5	8.0	5.0	9.53	6.89	1580	31.8	19.4	1.89	62.9	27.3	54.5	34.6	18.6	101	46.5	34.6	0.401	22.3	18.0	36.4	11.0	32.2	12.5	21.0	16.0	49.1	0.546
8 UA	10.3	7.8	8.0	5.0	11.8	8.62	1310	31.1	18.7	1.59	69.4	22.9	54.3	29.2	18.2	87.0	38.7	34.8	0.337	21.8	15.4	36.4	9.26	31.3	10.7	17.8	16.0	27.8	0.549
6 UA	7.98	6.0	8.0	5.0	15.7	11.5	1020	30.3	17.9	1.25	69.7	17.9	54.0	23.1	17.9	70.0	30.1	35.1	0.265	21.4	12.4	36.5	7.27	30.3	8.75	13.9	16.2	13.0	0.551
◆ 75 x 50 x 8 UA	7.23	7.8	7.0	3.0	8.62	5.41	921	25.2	12.8	0.586	50.8	11.5	37.8	15.5	18.0	32.5	20.0	25.2	0.106	14.2	7.46	26.4	4.01	21.7	4.88	8.19	10.7	19.5	0.430
6 UA	5.66	6.0	7.0	3.0	11.5	7.33	721	24.4	12.1	0.468	51.2	9.15	37.5	12.5	17.6	26.7	15.8	25.5	0.0842	13.6	6.17	26.5	3.18	20.8	4.04	6.48	10.8	9.21	0.435
5 UA	4.40	4.6	7.0	3.0	15.3	9.87	560	23.8	11.5	0.370	51.5	7.17	37.2	9.93	17.2	21.5	12.3	25.7	0.0666	13.2	5.03	26.6	2.50	20.1	3.32	5.09	10.9	4.32	0.437
◆ 65 x 50 x 8 UA	6.59	7.8	6.0	3.0	7.33	5.41	840	21.1	13.6	0.421	44.9	9.37	36.3	11.6	11.6	36.4	16.1	22.4	0.0936	15.6	6.00	23.9	3.91	22.3	4.20	7.49	10.6	17.6	0.570
6 UA	5.16	6.0	6.0	3.0	9.83	7.33	658	20.4	12.9	0.338	45.2	7.48	36.1	9.35	11.2	30.2	12.7	22.7	0.0743	15.1	4.91	23.9	3.11	21.4	3.48	5.93	10.6	8.29	0.575
◆ 5 UA	4.02	4.6	6.0	3.0	13.1	9.87	512	19.8	12.4	0.267	45.4	5.89	35.9	7.43	10.9	24.5	9.92	22.8	0.0587	14.8	3.97	23.9	2.46	20.6	2.85	4.66	10.7	3.87	0.577

◆ These items are not commonly stocked but are available on indent. A minimum order quantity may apply on some sizes.



# UNEQUAL ANGLES

## PROPERTIES FOR ASSESSING SECTION CAPACITY AS/NZS 3679.1-300

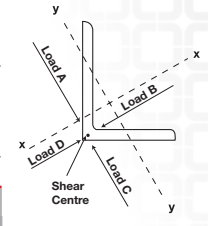

Designation	Yield stress $f_y$	Form factor $k_f$	About x-axis		About y-axis		Yield stress $f_y$	Form factor $k_f$	About x-axis		About y-axis	
			Load A $Z_{ex}$	Load C $Z_{ex}$	Load B $Z_{ey}$	Load D $Z_{ey}$			Load A $Z_{ex}$	Load C $Z_{ex}$	Load B $Z_{ey}$	Load D $Z_{ey}$
mm mm mm	MPa		$10^3\text{mm}^3$	$10^3\text{mm}^3$	$10^3\text{mm}^3$	$10^3\text{mm}^3$	MPa		$10^3\text{mm}^3$	$10^3\text{mm}^3$	$10^3\text{mm}^3$	$10^3\text{mm}^3$
<b>300PLUS</b>						<b>AS/NZS 3679.1-350</b>						
150 x 100 x 12 UA	300	1.00	102	110	35.3	38.2	340	1.00	100	110	34.7	38.2
10 UA	320	0.975	74.8	81.7	26.0	30.9	360	0.943	73.0	78.9	25.3	30.9
150 x 90 x 16 UA	300	1.00	132	133	39.5	39.8	340	1.00	130	133	39.0	39.8
12 UA	300	1.00	96.3	104	28.8	31.1	340	1.00	94.6	104	28.3	31.1
10 UA	320	0.973	70.6	81.8	21.2	25.2	360	0.940	68.8	79.5	20.6	25.2
8 UA	320	0.863	53.1	60.3	15.9	21.0	360	0.836	51.2	57.9	15.4	21.0
◆ 125 x 75 x 12 UA	300	1.00	68.6	70.5	20.6	21.2	340	1.00	67.6	70.5	20.3	21.2
10 UA	320	1.00	51.6	57.2	15.5	17.2	360	1.00	50.6	57.2	15.2	17.2
8 UA	320	0.964	39.8	46.0	11.9	14.3	360	0.931	38.8	44.7	11.6	14.3
6 UA	320	0.824	26.8	30.1	8.07	11.2	360	0.799	25.8	28.7	7.75	11.2
100 x 75 x 10 UA	320	1.00	39.4	40.9	15.9	16.6	360	1.00	38.8	40.9	15.7	16.6
8 UA	320	1.00	31.2	33.1	12.6	13.9	360	1.00	30.6	32.1	12.4	13.9
6 UA	320	0.946	22.0	21.8	8.93	10.9	360	0.917	21.4	20.7	8.68	10.9
◆ 75 x 50 x 8 UA	320	1.00	17.0	17.3	5.93	6.02	360	1.00	16.8	17.3	5.85	6.02
6 UA	320	1.00	12.6	13.7	4.37	4.77	360	1.00	12.4	13.7	4.30	4.77
5 UA	320	0.956	8.89	9.65	3.10	3.75	360	0.926	8.66	9.30	3.02	3.75
◆ 65 x 50 x 8 UA	320	1.00	14.1	14.1	5.86	5.86	360	1.00	14.1	14.1	5.86	5.86
6 UA	320	1.00	10.7	11.2	4.46	4.67	360	1.00	10.6	11.2	4.40	4.67
◆ 5 UA	320	1.00	7.76	7.92	3.23	3.68	360	1.00	7.59	7.64	3.17	3.68

- Notes:**
- For 300PLUS sections the tensile strength ( $f_u$ ) is 440 MPa.
  - For grade 350 sections the tensile strength ( $f_u$ ) is 480 MPa.
  - 300PLUS hot-rolled sections are produced to exceed the minimum requirements of AS/NZS 3679.1-300.
  - 300PLUS replaced grade 250 as the base grade for these sections in 1994.

◆ These items are not commonly stocked but are available on indent. A minimum order quantity may apply on some sizes.

# UNEQUAL ANGLES

## N- AND P-AXES DIMENSIONS AND PROPERTIES AS/NZS 3679.1-300

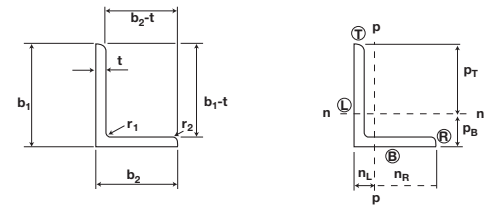

Designation	About n-axis							About p-axis							Product of 2nd moment of area $I_{np}$
	$I_n$	$P_B$	$Z_{nB}$	$P_T$	$Z_{nT}$	$S_n$	$r_n$	$I_p$	$n_L$	$Z_{pL}$	$n_R$	$Z_{pR}$	$S_p$	$r_p$	
mm mm mm	$10^6\text{mm}^4$	mm	$10^3\text{mm}^3$	mm	$10^3\text{mm}^3$	$10^3\text{mm}^3$	mm	$10^6\text{mm}^4$	mm	$10^3\text{mm}^3$	mm	$10^3\text{mm}^3$	$10^3\text{mm}^3$	mm	$10^6\text{mm}^4$
150 x 100 x 12 UA	6.52	49.1	133	101	64.6	117	47.7	2.34	24.3	96.2	75.7	30.9	56.0	28.6	-2.27
10 UA	5.29	48.1	110	102	51.9	94.0	48.0	1.91	23.3	81.9	76.7	24.9	44.7	28.8	-1.85
150 x 90 x 16 UA	7.97	52.5	152	97.5	81.7	145	47.4	2.15	22.7	94.9	67.3	32.0	59.5	24.6	-2.35
12 UA	6.29	51.0	123	99.0	63.5	114	47.8	1.72	21.2	81.0	68.8	25.0	45.7	25.0	-1.89
10 UA	5.10	50.0	102	100	51.0	91.5	48.2	1.41	20.2	69.5	69.8	20.2	36.5	25.3	-1.54
8 UA	4.26	49.2	86.6	101	42.3	76.0	48.4	1.18	19.6	60.4	70.4	16.8	30.1	25.5	-1.29
125 x 75 x 12 UA	3.54	43.3	81.8	81.7	43.3	77.3	39.6	0.958	18.4	52.0	56.6	16.9	31.4	20.6	-1.05
10 UA	2.88	42.3	68.2	82.7	34.9	62.5	39.9	0.789	17.5	45.2	57.5	13.7	25.1	20.9	-0.867
8 UA	2.41	41.5	58.1	83.5	28.9	52.0	40.1	0.664	16.8	39.6	58.2	11.4	20.7	21.0	-0.731
6 UA	1.89	40.7	46.5	84.3	22.5	40.6	40.3	0.524	16.0	32.7	59.0	8.89	16.0	21.2	-0.575
100 x 75 x 10 UA	1.55	31.8	48.6	68.2	22.6	41.3	31.3	0.743	19.4	38.3	55.6	13.4	24.3	21.7	-0.625
8 UA	1.30	31.1	41.8	68.9	18.8	34.4	31.5	0.626	18.7	33.5	56.3	11.1	20.2	21.9	-0.528
6 UA	1.02	30.3	33.7	69.7	14.6	26.9	31.7	0.494	17.9	27.5	57.1	8.67	15.7	22.0	-0.416
◆ 75 x 50 x 8 UA	0.511	25.2	20.3	49.8	10.3	18.5	23.6	0.181	12.8	14.1	37.2	4.86	8.96	14.0	-0.174
6 UA	0.407	24.4	16.7	50.6	8.05	14.6	23.8	0.145	12.1	12.0	37.9	3.84	6.98	14.2	-0.140
5 UA	0.321	23.8	13.5	51.2	6.27	11.4	23.9	0.115	11.5	10.0	38.5	3.00	5.41	14.3	-0.111
◆ 65 x 50 x 8 UA	0.341	21.1	16.2	43.9	7.75	14.1	20.1	0.174	13.6	12.7	36.4	4.78	8.74	14.4	-0.141
6 UA	0.272	20.4	13.4	44.6	6.10	11.1	20.3	0.140	12.9	10.8	37.1	3.77	6.85	14.6	-0.114
◆ 5 UA	0.215	19.8	10.9	45.2	4.75	8.70	20.5	0.111	12.4	8.96	37.6	2.95	5.32	14.7	-0.0903

◆ These items are not commonly stocked but are available on indent. A minimum order quantity may apply on some sizes.

# RECTANGULAR HOLLOW SECTIONS

## DIMENSIONS AND PROPERTIES GRADE C350L0 AS/NZS 1163

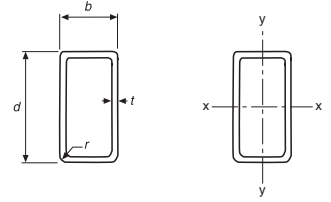

DIMENSIONS AND RATIOS						PROPERTIES										PROPERTIES FOR DESIGN TO AS 4100									
Designation			Mass per metre	External surface area		b-2t	d-2t	Gross section area	About x-axis				About y-axis				Torsion constant modulus		Form factor	About x-axis			About y-axis		
d	b	t		per m	per t				t	t	A <sub>g</sub>	I <sub>x</sub>	Z <sub>x</sub>	S <sub>x</sub>	r <sub>x</sub>	I <sub>y</sub>	Z <sub>y</sub>	S <sub>y</sub>		r <sub>y</sub>	J	C	k <sub>f</sub>	λ <sub>ex</sub>	Compactness <sup>(1)</sup>
mm	mm	mm	kg/m	m <sup>2</sup> /m	m <sup>2</sup> /t	t	t	mm <sup>2</sup>	10 <sup>6</sup> mm <sup>4</sup>	10 <sup>3</sup> mm <sup>3</sup>	10 <sup>3</sup> mm <sup>2</sup>	mm	10 <sup>6</sup> mm <sup>4</sup>	10 <sup>3</sup> mm <sup>3</sup>	10 <sup>3</sup> mm <sup>2</sup>	mm	10 <sup>6</sup> mm <sup>4</sup>	10 <sup>6</sup> mm <sup>3</sup>			(C,N,S)	10 <sup>3</sup> mm <sup>3</sup>		(C,N,S)	10 <sup>3</sup> mm <sup>3</sup>
250 x 150 x 9.0	RHS	51.8	0.761	14.7	14.7	25.8	6600	53.7	430	533	90.2	24.3	324	375	60.7	56.0	554	1.00	17.4	C	533	30.5	N	373	
6.0	RHS	35.6	0.774	21.8	23.0	39.7	4530	38.4	307	374	92.0	17.5	233	264	62.2	39.0	395	0.907	27.2	C	374	46.9	S	208	
5.0	RHS	29.9	0.779	26.0	28.0	48.0	3810	32.7	262	317	92.6	15.0	199	224	62.6	33.0	337	0.814	33.1	N	300	56.8	S	156	
200 x 100 x 9.0	RHS	37.7	0.561	14.9	9.11	20.2	4800	22.8	228	293	68.9	7.64	153	180	39.9	19.9	272	1.00	10.8	C	293	23.9	C	180	
6.0	RHS	26.2	0.574	22.0	14.7	31.3	3330	16.7	167	210	70.8	5.69	114	130	41.3	14.2	200	1.00	17.4	C	210	37.1	N	119	
5.0	RHS	22.1	0.579	26.2	18.0	38.0	2810	14.4	144	179	71.5	4.92	98.3	111	41.8	12.1	172	0.925	21.3	C	179	45.0	S	90.1	
4.0	RHS	17.9	0.583	32.5	23.0	48.0	2280	11.9	119	147	72.1	4.07	81.5	91.0	42.3	9.89	142	0.801	27.2	C	147	56.8	S	63.1	
152 x 76 x 6.0	RHS	19.4	0.431	22.2	10.7	23.4	2480	6.97	91.4	117	53.0	2.35	61.7	71.9	30.8	6.03	109	1.00	12.7	C	117	27.7	C	71.9	
5.0	RHS	16.5	0.436	26.4	13.2	28.5	2100	6.06	79.5	100	53.7	2.06	54.0	62.0	31.3	5.18	94.9	1.00	15.7	C	100	33.7	N	59.0	
150 x 100 x 9.0	RHS	30.6	0.461	15.1	9.11	14.7	3900	10.9	145	185	52.9	5.77	115	140	38.5	13.2	197	1.00	10.8	C	185	17.4	C	140	
6.0	RHS	21.4	0.474	22.1	14.7	23.0	2730	8.17	109	134	54.7	4.36	87.3	102	40.0	9.51	147	1.00	17.4	C	134	27.2	C	102	
5.0	RHS	18.2	0.479	26.3	18.0	28.0	2310	7.07	94.3	115	55.3	3.79	75.7	87.3	40.4	8.12	127	1.00	21.3	C	115	33.1	N	83.6	
4.0	RHS	14.8	0.483	32.7	23.0	35.5	1880	5.87	78.2	94.6	55.9	3.15	63.0	71.8	40.9	6.64	105	0.971	27.2	C	94.6	42.0	S	60.9	
◆	150 x 50 x 6.0	RHS	16.7	0.374	22.4	6.33	23.0	2130	5.06	67.5	91.2	48.7	0.860	34.4	40.9	20.1	2.63	64.3	1.00	7.49	C	91.2	27.2	C	40.9
5.0	RHS	14.2	0.379	26.6	8.00	28.0	1810	4.44	59.2	78.9	49.5	0.765	30.6	35.7	20.5	2.30	56.8	1.00	9.47	C	78.9	33.1	N	34.1	
4.0	RHS	11.6	0.383	32.9	10.5	35.5	1480	3.74	49.8	65.4	50.2	0.653	26.1	29.8	21.0	1.93	48.2	0.963	12.4	C	65.4	42.0	S	25.1	
3.0	RHS	8.96	0.390	43.5	14.7	48.0	1140	2.99	39.8	51.4	51.2	0.526	21.1	23.5	21.5	1.50	38.3	0.776	17.4	C	51.4	56.8	S	16.0	
◆	2.5	RHS	7.53	0.391	52.0	18.0	58.0	959	2.54	33.9	43.5	51.5	0.452	18.1	19.9	21.7	1.28	32.8	0.685	21.3	C	43.5	68.6	S	11.9
◆	2.0	RHS	6.07	0.393	64.7	23.0	73.0	774	2.08	27.7	35.3	51.8	0.372	14.9	16.3	21.9	1.04	26.9	0.595	27.2	C	34.3	86.4	S	8.32
◆	127 x 51 x 6.0	RHS	14.7	0.330	22.5	6.50	19.2	1868	3.28	51.6	68.9	41.9	0.761	29.8	35.8	20.2	2.20	54.9	1.00	8.72	C	68.9	25.7	C	35.8
5.0	RHS	12.5	0.335	26.7	8.20	23.4	1594	2.89	45.6	59.9	42.6	0.679	26.6	31.3	20.6	1.93	48.6	1.00	11.0	C	59.9	31.4	N	30.6	
3.5	RHS	9.07	0.341	37.6	12.6	34.3	1155	2.20	34.7	44.6	43.7	0.526	20.6	23.4	21.3	1.44	37.2	0.905	16.9	C	44.6	46.0	S	18.5	
125 x 75 x 6.0	RHS	16.7	0.374	22.4	10.5	18.8	2130	4.16	66.6	84.2	44.2	1.87	50.0	59.1	29.6	4.44	86.2	1.00	12.4	C	84.2	22.3	C	59.1	
5.0	RHS	14.2	0.379	26.6	13.0	23.0	1810	3.64	58.3	72.7	44.8	1.65	43.9	51.1	30.1	3.83	75.3	1.00	15.4	C	72.7	27.2	C	51.1	
4.0	RHS	11.6	0.383	32.9	16.8	29.3	1480	3.05	48.9	60.3	45.4	1.39	37.0	42.4	30.6	3.16	63.0	1.00	19.8	C	60.3	34.6	N	39.9	
3.0	RHS	8.96	0.390	43.5	23.0	39.7	1140	2.43	38.9	47.3	46.1	1.11	29.5	33.3	31.1	2.43	49.5	0.908	27.2	C	47.3	46.9	S	26.3	

◆ These items are not commonly stocked but are available on indent. A minimum order quantity may apply on some sizes.

### Notes:

- This table is calculated in accordance with AS 4100 using design yield stress  $f_y = 350$  MPa and design tensile strength  $f_u = 430$  MPa as per AS 4100 table 2.1 for AS 1163 grade C350L0.
- Grade C350L0 is cold-formed and therefore is allocated the CF residual-stresses classification in AS 4100.
- C = compact section; N = non-compact section; S = slender section; as defined in AS 4100.
- For rectangular hollow sections (RHS) the smallest corner radius  $r$  used in calculating the section properties is equal to  $2t$  for sections with thickness  $t < 3.0$ mm and  $2.5t$  for sections with  $t > 3.0$ mm.

# RECTANGULAR HOLLOW SECTIONS

**DIMENSIONS AND PROPERTIES**  
**GRADE C350LO**  
**AS/NZS 1163**

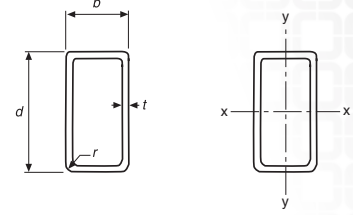

DIMENSIONS AND RATIOS							PROPERTIES										PROPERTIES FOR DESIGN TO AS 4100								
Designation			Mass per metre	External surface area		Gross section area		About x-axis				About y-axis				Torsion constant		Torsion modulus	Form factor	About x-axis			About y-axis		
d	b	t	per m	per t	b-2t	d-2t	A <sub>g</sub>	I <sub>x</sub>	Z <sub>x</sub>	S <sub>x</sub>	r <sub>x</sub>	I <sub>y</sub>	Z <sub>y</sub>	S <sub>y</sub>	r <sub>y</sub>	J	C	k <sub>f</sub>	λ <sub>ex</sub>	Compactness <sup>(1)</sup>	Z <sub>ex</sub>	λ <sub>ey</sub>	Compactness <sup>(1)</sup>	Z <sub>ey</sub>	
mm	mm	mm	kg/m	m <sup>2</sup> /m	m <sup>2</sup> /t	t	t	mm <sup>2</sup>	10 <sup>6</sup> mm <sup>4</sup>	10 <sup>3</sup> mm <sup>3</sup>	10 <sup>3</sup> mm <sup>3</sup>	mm	10 <sup>6</sup> mm <sup>4</sup>	10 <sup>3</sup> mm <sup>3</sup>	10 <sup>3</sup> mm <sup>3</sup>	mm	10 <sup>6</sup> mm <sup>4</sup>	10 <sup>6</sup> mm <sup>2</sup>		(C,N,S)	10 <sup>3</sup> mm <sup>3</sup>	(C,N,S)	10 <sup>3</sup> mm <sup>3</sup>		
102 x 76 x 6.0 RHS	14.7	0.330	22.5	10.7	15.0	1868	2.52	49.4	61.9	36.7	1.59	42.0	50.5	29.2	3.38	69.8	1.00	14.3	C	61.9	20.1	C	50.5		
5.0 RHS	12.5	0.335	26.7	13.2	18.4	1594	2.22	43.5	53.7	37.3	1.41	37.0	43.9	29.7	2.91	61.2	1.00	17.7	C	53.7	24.7	C	43.9		
3.5 RHS	9.07	0.341	37.6	19.7	27.1	1155	1.68	33.0	39.9	38.2	1.07	28.2	32.6	30.5	2.14	46.1	1.00	26.4	C	39.9	36.4	N	29.8		
100 x 50 x 6.0 RHS	12.0	0.274	22.8	6.33	14.7	1530	1.71	34.2	45.3	33.4	0.567	22.7	27.7	19.2	1.53	40.9	1.00	7.49	C	45.3	17.4	C	27.7		
5.0 RHS	10.3	0.279	27.0	8.00	18.0	1310	1.53	30.6	39.8	34.1	0.511	20.4	24.4	19.7	1.35	36.5	1.00	9.47	C	39.8	21.3	C	24.4		
4.0 RHS	8.49	0.283	33.3	10.5	23.0	1080	1.31	26.1	33.4	34.8	0.441	17.6	20.6	20.2	1.13	31.2	1.00	12.4	C	33.4	27.2	C	20.6		
3.0 RHS	6.60	0.290	43.9	14.7	31.3	841	1.06	21.3	26.7	35.6	0.361	14.4	16.4	20.7	0.886	25.0	1.00	17.4	C	26.7	37.1	N	15.0		
75 x 50 x 6.0 RHS	9.67	0.224	23.2	6.33	10.5	1230	0.800	21.3	28.1	25.5	0.421	16.9	21.1	18.5	1.01	29.3	1.00	7.49	C	28.1	12.4	C	21.1		
5.0 RHS	8.35	0.229	27.4	8.00	13.0	1060	0.726	19.4	24.9	26.1	0.384	15.4	18.8	19.0	0.891	26.4	1.00	9.47	C	24.9	15.4	C	18.8		
4.0 RHS	6.92	0.233	33.7	10.5	16.8	881	0.630	16.8	21.1	26.7	0.335	13.4	16.0	19.5	0.754	22.7	1.00	12.4	C	21.1	19.8	C	16.0		
3.0 RHS	5.42	0.240	44.2	14.7	23.0	691	0.522	13.9	17.1	27.5	0.278	11.1	12.9	20.0	0.593	18.4	1.00	17.4	C	17.1	27.2	C	12.9		
75 x 40 x 4.0 RHS	6.29	0.213	33.85	8.00	16.8	801	0.53	14.06	18.37	25.7	0.20	9.78	11.84	15.6	0.504	17.4	1.00	10.73	C	18.37	22.47	C	11.84		
3.0 RHS	4.95	0.220	44.37	11.33	23.0	631	0.44	11.83	14.94	26.5	0.17	8.25	9.62	16.2	0.402	14.3	1.00	15.21	C	14.94	30.86	N	6.24		
2.5 RHS	4.19	0.221	52.83	14.00	28.0	534	0.38	10.23	12.79	26.8	0.14	7.18	8.25	16.4	0.344	12.4	1.00	18.78	C	12.79	37.57	N	6.70		
65 x 35 x 4.0 RHS	5.35	0.183	34.2	6.75	14.3	681	0.328	10.1	13.3	22.0	0.123	7.03	8.58	13.4	0.320	12.5	1.00	7.99	C	13.3	16.9	C	8.58		
3.0 RHS	4.25	0.190	44.7	9.67	19.7	541	0.281	8.65	11.0	22.8	0.106	6.04	7.11	14.0	0.259	10.4	1.00	11.4	C	11.0	23.3	C	7.11		
2.5 RHS	3.60	0.191	53.1	12.0	24.0	459	0.244	7.52	9.45	23.1	0.0926	5.29	6.13	14.2	0.223	9.10	1.00	14.2	C	9.45	28.4	C	6.13		
50 x 25 x 3.0 RHS	3.07	0.140	45.5	6.33	14.7	391	0.112	4.47	5.86	16.9	0.0367	2.93	3.56	9.69	0.0964	5.18	1.00	7.49	C	5.86	17.4	C	3.56		
2.5 RHS	2.62	0.141	54.0	8.00	18.0	334	0.0989	3.95	5.11	17.2	0.0328	2.62	3.12	9.91	0.0843	4.60	1.00	9.47	C	5.11	21.3	C	3.12		
2.0 RHS	2.15	0.143	66.6	10.5	23.0	274	0.0838	3.35	4.26	17.5	0.0281	2.25	2.62	10.1	0.0706	3.92	1.00	12.4	C	4.26	27.2	C	2.62		

Dualgrade C350LO/C450LO hollow sections have a minimum yield stress of 450MPa ( $f_y = 450$  MPa), a minimum tensile strength of 500 MPa ( $f_u = 500$  MPa) and a minimum elongation equal to 16%, ie the strength of AS 1163 grade C450LO and the elongation of AS 1163 grade C350LO.

**Notes:**

- This table is calculated in accordance with AS 4100 using design yield stress  $f_y = 350$  MPa and design tensile strength  $f_u = 430$  MPa as per AS 4100 table 2.1 for AS 1163 grade C350LO.
- Grade C350LO is cold-formed and therefore is allocated the CF residual-stresses classification in AS 4100.
- C = compact section; N = non-compact section; S = slender section; as defined in AS 4100.
- For rectangular hollow sections (RHS) the outside corner radius  $r$  used in calculating the section properties is equal to  $2t$  for sections with thickness  $t < 3.0$ mm and  $2.5t$  for sections with  $t > 3.0$ mm.

# DURAGAL RECTANGULAR HOLLOW SECTIONS

**DIMENSIONS AND PROPERTIES**  
**GRADE C450L0**  
**AS/NZS 1163**

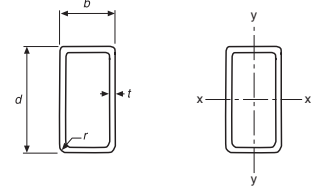

DIMENSIONS AND RATIOS										PROPERTIES								PROPERTIES FOR DESIGN TO AS 4100								
Designation			Mass per metre	External surface area		Gross section area		About x-axis				About y-axis				Torsion constant modulus		Form factor	About x-axis				About y-axis			
d	b	t		per m	per t	b-2t	d-2t	A <sub>g</sub>	I <sub>x</sub>	Z <sub>x</sub>	S <sub>x</sub>	r <sub>x</sub>	I <sub>y</sub>	Z <sub>y</sub>	S <sub>y</sub>	r <sub>y</sub>	J		C	k <sub>f</sub>	λ <sub>ex</sub>	Compactness <sup>(3)</sup>	Z <sub>ex</sub>	λ <sub>ey</sub>	Compactness <sup>(3)</sup>	Z <sub>ey</sub>
mm	mm	mm	kg/m	m <sup>2</sup> /m	m <sup>2</sup> /t	t	t	mm <sup>2</sup>	10 <sup>6</sup> mm <sup>4</sup>	10 <sup>6</sup> mm <sup>3</sup>	10 <sup>6</sup> mm <sup>2</sup>	mm	10 <sup>6</sup> mm <sup>4</sup>	10 <sup>6</sup> mm <sup>3</sup>	10 <sup>6</sup> mm <sup>2</sup>	mm	10 <sup>6</sup> mm <sup>4</sup>	10 <sup>6</sup> mm <sup>2</sup>			(C,N,S)	10 <sup>6</sup> mm <sup>3</sup>	(C,N,S)	10 <sup>6</sup> mm <sup>3</sup>		
◆	150 x 50 x 6.0	RHS	16.7	0.374	22.4	6.33	23.0	2130	5.06	67.5	91.2	48.7	0.860	34.4	40.9	20.1	2.63	64.3	1.00	8.50	C	91.2	30.9	N	40.4	
	5.0	RHS	14.2	0.379	26.6	8.00	28.0	1810	4.44	59.2	78.9	49.5	0.765	30.6	35.7	20.5	2.30	56.8	1.00	10.7	C	78.9	37.6	N	31.8	
◆	4.0	RHS	11.6	0.383	32.9	10.5	35.5	1480	3.74	49.8	65.4	50.2	0.653	26.1	29.8	21.0	1.93	48.2	0.877	14.1	C	65.4	47.6	S	22.7	
	3.0	RHS	8.96	0.390	43.5	14.7	48.0	1140	2.99	39.8	51.4	51.2	0.526	21.1	23.5	21.5	1.50	38.3	0.713	19.7	C	51.4	64.4	S	14.5	
◆	2.5	RHS	7.53	0.391	52.0	18.0	58.0	959	2.54	33.9	43.5	51.5	0.452	18.1	19.9	21.7	1.28	32.8	0.633	24.1	C	43.5	77.8	S	10.9	
◆	2.0	RHS	6.07	0.393	64.7	23.0	73.0	774	2.08	27.7	35.3	51.8	0.372	14.9	16.3	21.9	1.04	26.9	0.553	30.9	N	31.6	97.9	S	7.64	
◆	125 x 75 x 6.0	RHS	16.7	0.374	22.4	10.5	18.8	2130	4.16	66.6	84.2	44.2	1.87	50.0	59.1	29.6	4.44	86.2	1.00	14.1	C	84.2	25.3	C	59.1	
	5.0	RHS	14.2	0.379	26.6	13.0	23.0	1810	3.64	58.3	72.7	44.8	1.65	43.9	51.1	30.1	3.83	75.3	1.00	17.4	C	72.7	30.9	N	50.5	
	4.0	RHS	11.6	0.383	32.9	16.8	29.3	1480	3.05	48.9	60.3	45.4	1.39	37.0	42.4	30.6	3.16	63.0	1.00	22.5	C	60.3	39.2	N	37.4	
	3.0	RHS	8.96	0.390	43.5	23.0	39.7	1140	2.43	38.9	47.3	46.1	1.11	29.5	33.3	31.1	2.43	49.5	0.845	30.9	N	46.5	53.2	S	24.2	
◆	2.5	RHS	7.53	0.391	52.0	28.0	48.0	959	2.07	33.0	40.0	46.4	0.942	25.1	28.2	31.4	2.05	42.1	0.763	37.6	N	34.7	64.4	S	18.2	
◆	2.0	RHS	6.07	0.393	64.7	35.5	60.5	774	1.69	27.0	32.5	46.7	0.771	20.6	22.9	31.6	1.67	34.4	0.624	47.6	S	24.8	81.2	S	13.0	
◆	100 x 50 x 6.0	RHS	12.0	0.274	22.8	6.33	14.7	1530	1.71	34.2	45.3	33.4	0.567	22.7	27.7	19.2	1.53	40.9	1.00	8.50	C	45.3	19.7	C	27.7	
	5.0	RHS	10.3	0.279	27.0	8.00	18.0	1310	1.53	30.6	39.8	34.1	0.511	20.4	24.4	19.7	1.35	36.5	1.00	10.7	C	39.8	24.1	C	24.4	
	4.0	RHS	8.49	0.283	33.3	10.5	23.0	1080	1.31	26.1	33.4	34.8	0.441	17.6	20.6	20.2	1.13	31.2	1.00	14.1	C	33.4	30.9	N	20.3	
	3.5	RHS	7.53	0.285	37.9	12.3	26.6	959	1.18	23.6	29.9	35.1	0.400	16.0	18.5	20.4	1.01	28.2	1.00	16.5	C	29.9	35.6	N	17.1	
	3.0	RHS	6.60	0.290	43.9	14.7	31.3	841	1.06	21.3	26.7	35.6	0.361	14.4	16.4	20.7	0.886	25.0	0.967	19.7	C	26.7	42.0	S	13.9	
	2.5	RHS	5.56	0.291	52.4	18.0	38.0	709	0.912	18.2	22.7	35.9	0.311	12.4	14.0	20.9	0.754	21.5	0.856	24.1	C	22.7	51.0	S	10.4	
◆	2.0	RHS	4.50	0.293	65.1	23.0	48.0	574	0.750	15.0	18.5	36.2	0.257	10.3	11.5	21.2	0.616	17.7	0.746	30.9	N	18.2	64.4	S	7.33	
◆	1.6	RHS	3.64	0.295	81.0	29.3	60.5	463	0.613	12.3	15.0	36.4	0.211	8.43	9.33	21.3	0.501	14.5	0.661	39.2	N	12.5	81.2	S	5.19	

◆ These items are not commonly stocked but are available on indent. A minimum order quantity may apply on some sizes.

**Notes:**

- This table is calculated in accordance with AS 4100 using design yield stress  $f_y = 450$  MPa and design tensile strength  $f_u = 500$  MPa as per AS 4100 table 2.1 for AS 1163 grade C450L0.
- Grade C450L0 is cold-formed and therefore is allocated the CF residual-stresses classification in AS 4100.
- C = compact section; N = non-compact section; S = slender section; as defined in AS 4100.
- For rectangular hollow sections (RHS) the outside corner radius  $r$  used in calculating the section properties is equal to  $2t$  for sections with thickness  $t \leq 3.0$ mm and  $2.5t$  for sections with  $t > 3.0$ mm.
- Dualgrade C350L0/C450L0 hollow sections have a minimum yield stress of 450MPa ( $f_y = 450$ MPa), a minimum tensile strength of 500MPa ( $f_u = 500$  MPa) and a minimum elongation equal to 16%, ie the strength of AS 1163 grade C450L0 and the elongation of AS 1163 grade C350L0.

• **Please Note:** Product brand name change: 'SupaGal' is now 'DuraGal'.



# DURAGAL RECTANGULAR HOLLOW SECTIONS

## DIMENSIONS AND PROPERTIES GRADE C450L0 AS/NZS 1163

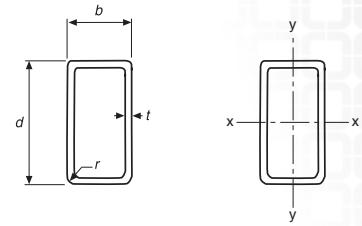

DIMENSIONS AND RATIOS							PROPERTIES										PROPERTIES FOR DESIGN TO AS 4100							
Designation		Mass per metre	External surface area		Gross section area		About x-axis				About y-axis				Torsion constant	Torsion modulus	Form factor	About x-axis		About y-axis				
d	b	t	per m	per t	b-2t	d-2t	A <sub>g</sub>	I <sub>x</sub>	Z <sub>x</sub>	S <sub>x</sub>	r <sub>x</sub>	I <sub>y</sub>	Z <sub>y</sub>	S <sub>y</sub>	r <sub>y</sub>	J	C	k <sub>f</sub>	λ <sub>ex</sub>	Compactness <sup>(3)</sup>	Z <sub>ex</sub>	λ <sub>ey</sub>	Compactness <sup>(3)</sup>	Z <sub>ey</sub>
mm	mm	mm	kg/m	m <sup>2</sup> /m	m <sup>2</sup> /t	t	mm <sup>2</sup>	10 <sup>6</sup> mm <sup>4</sup>	10 <sup>3</sup> mm <sup>3</sup>	10 <sup>3</sup> mm <sup>3</sup>	mm	10 <sup>6</sup> mm <sup>4</sup>	10 <sup>3</sup> mm <sup>3</sup>	10 <sup>3</sup> mm <sup>3</sup>	mm	10 <sup>6</sup> mm <sup>4</sup>	10 <sup>6</sup> mm <sup>4</sup>			(C,N,S)	10 <sup>3</sup> mm <sup>3</sup>		(C,N,S)	10 <sup>3</sup> mm <sup>3</sup>
◆	75 x 50 x 6.0 RHS	9.67	0.224	23.2	6.33	10.5	1230	0.800	21.3	28.1	25.5	0.421	16.9	21.1	18.5	1.01	29.3	1.00	8.50	C	28.1	14.1	C	21.1
◆	5.0 RHS	8.35	0.229	27.4	8.00	13.0	1060	0.726	19.4	24.9	26.1	0.384	15.4	18.8	19.0	0.891	26.4	1.00	10.7	C	24.9	17.4	C	18.8
◆	4.0 RHS	6.92	0.233	33.7	10.5	16.8	881	0.630	16.8	21.1	26.7	0.335	13.4	16.0	19.5	0.754	22.7	1.00	14.1	C	21.1	22.5	C	16.0
	3.0 RHS	5.42	0.240	44.2	14.7	23.0	691	0.522	13.9	17.1	27.5	0.278	11.1	12.9	20.0	0.593	18.4	1.00	19.7	C	17.1	30.9	N	12.8
	2.5 RHS	4.58	0.241	52.7	18.0	28.0	584	0.450	12.0	14.6	27.7	0.240	9.60	11.0	20.3	0.505	15.9	1.00	24.1	C	14.6	37.6	N	9.95
	2.0 RHS	3.72	0.243	65.4	23.0	35.5	474	0.372	9.91	12.0	28.0	0.199	7.96	9.06	20.5	0.414	13.1	0.904	30.9	N	11.8	47.6	S	7.07
◆	1.6 RHS	3.01	0.245	81.3	29.3	44.9	383	0.305	8.14	9.75	28.2	0.164	6.56	7.40	20.7	0.337	10.8	0.799	39.2	N	8.26	60.2	S	5.01
◆	75 x 25 x 2.5 RHS	3.60	0.191	53.1	8.00	28.0	459	0.285	7.60	10.1	24.9	0.0487	3.89	4.53	10.3	0.144	7.14	1.00	10.7	C	10.1	37.6	N	4.05
◆	2.0 RHS	2.93	0.193	65.8	10.5	35.5	374	0.238	6.36	8.31	25.3	0.0414	3.31	3.77	10.5	0.120	6.04	0.878	14.1	C	8.31	47.6	S	2.88
◆	1.6 RHS	2.38	0.195	81.7	13.6	44.9	303	0.197	5.26	6.81	25.5	0.0347	2.78	3.11	10.7	0.0993	5.05	0.746	18.3	C	6.81	60.2	S	2.02
◆	65 x 35 x 4.0 RHS	5.35	0.183	34.2	6.75	14.3	681	0.328	10.1	13.3	22.0	0.123	7.03	8.58	13.4	0.320	12.5	1.00	9.06	C	13.3	19.1	C	8.58
	3.0 RHS	4.25	0.190	44.7	9.67	19.7	541	0.281	8.65	11.0	22.8	0.106	6.04	7.11	14.0	0.259	10.4	1.00	13.0	C	11.0	26.4	C	7.11
	2.5 RHS	3.60	0.191	53.1	12.0	24.0	459	0.244	7.52	9.45	23.1	0.0926	5.29	6.13	14.2	0.223	9.10	1.00	16.1	C	9.45	32.2	N	5.95
	2.0 RHS	2.93	0.193	65.8	15.5	30.5	374	0.204	6.28	7.80	23.4	0.0778	4.44	5.07	14.4	0.184	7.62	0.985	20.8	C	7.80	40.9	S	4.37
	50 x 25 x 3.0 RHS	3.07	0.140	45.5	6.33	14.7	391	0.112	4.47	5.86	16.9	0.0367	2.93	3.56	9.69	0.0964	5.18	1.00	8.50	C	5.86	19.7	C	3.56
	2.5 RHS	2.62	0.141	54.0	8.00	18.0	334	0.0989	3.95	5.11	17.2	0.0328	2.62	3.12	9.91	0.0843	4.60	1.00	10.7	C	5.11	24.1	C	3.12
	2.0 RHS	2.15	0.143	66.6	10.5	23.0	274	0.0838	3.35	4.26	17.5	0.0281	2.25	2.62	10.1	0.0706	3.92	1.00	14.1	C	4.26	30.9	N	2.58
	1.6 RHS	1.75	0.145	82.5	13.6	29.3	223	0.0702	2.81	3.53	17.7	0.0237	1.90	2.17	10.3	0.0585	3.29	1.00	18.3	C	3.53	39.2	N	1.92
◆	50 x 20 x 3.0 RHS	2.83	0.130	45.8	4.67	14.7	361	0.0951	3.81	5.16	16.2	0.0212	2.12	2.63	7.67	0.0620	3.88	1.00	6.26	C	5.16	19.7	C	2.63
◆	2.5 RHS	2.42	0.131	54.2	6.00	18.0	309	0.0848	3.39	4.51	16.6	0.0192	1.92	2.32	7.89	0.0550	3.49	1.00	8.05	C	4.51	24.1	C	2.32
◆	2.0 RHS	1.99	0.133	66.8	8.00	23.0	254	0.0723	2.89	3.78	16.9	0.0167	1.67	1.96	8.11	0.0466	3.00	1.00	10.7	C	3.78	30.9	N	1.93
◆	1.6 RHS	1.63	0.135	82.7	10.5	29.3	207	0.0608	2.43	3.14	17.1	0.0142	1.42	1.63	8.29	0.0389	2.55	1.00	14.1	C	3.14	39.2	N	1.44

◆ These items are not commonly stocked but are available on indent. A minimum order quantity may apply on some sizes.

### Notes:

- This table is calculated in accordance with AS 4100 using design yield stress  $f_y = 450$  MPa and design tensile strength  $f_u = 500$  MPa as per AS 4100 table 2.1 for AS 1163 grade C450L0.
- Grade C450L0 is cold-formed and therefore is allocated the CF residual-stresses classification in AS 4100.
- C = compact section; N = non-compact section; S = slender section; as defined in AS 4100.
- For rectangular hollow sections (RHS) the outside corner radius  $r$  used in calculating the section properties is equal to  $2t$  for sections with thickness  $t \leq 3.0$ mm and  $2.5t$  for sections with  $t > 3.0$ mm.
- Dualgrade C350L0/C450L0 hollow sections have a minimum yield stress of 450MPa ( $f_y = 450$ MPa), a minimum tensile strength of 500MPa ( $f_u = 500$  MPa) and a minimum elongation equal to 16%, ie the strength of AS 1163 grade C450L0 and the elongation of AS 1163 grade C350L0.

• **Please Note:** Product brand name change: 'SupaGal' is now 'DuraGal'.

# SQUARE HOLLOW SECTIONS

## DIMENSIONS AND PROPERTIES GRADE C350LO AS/NZS 1163

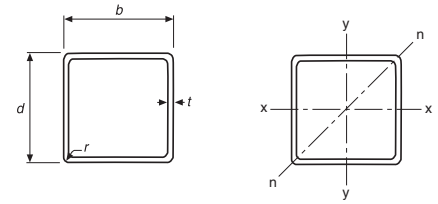

Designation				Mass per metre		External surface area		Gross section area		About x-, y- and z-axis					Torsion			Form factor			About x- and y-axis	
d	b	t		per m	per t	(b-2t)	A <sub>g</sub>	I <sub>x</sub>	Z <sub>x</sub>	Z <sub>y</sub>	S <sub>x</sub>	r <sub>x</sub>	J	C	k <sub>f</sub>	λ <sub>e</sub>	Compactness <sup>(1)</sup>	Z <sub>e</sub>				
mm	mm	mm		kg/m	m <sup>2</sup> /m	m <sup>2</sup> /t	mm <sup>2</sup>	10 <sup>6</sup> mm <sup>4</sup>	10 <sup>3</sup> mm <sup>3</sup>	10 <sup>3</sup> mm <sup>3</sup>	10 <sup>3</sup> mm <sup>3</sup>	mm	10 <sup>6</sup> mm <sup>4</sup>	10 <sup>3</sup> mm <sup>3</sup>			(C,N,S)	10 <sup>3</sup> mm <sup>3</sup>				
250 x 250 x 9.0 SHS	65.9	0.961	14.6	25.8	8400	79.8	639	477	750	97.5	129	972	1.00	30.5	N	744						
6.0 SHS	45.0	0.974	21.7	39.7	5730	56.2	450	330	521	99.0	88.7	681	0.853	46.9	S	409						
200 x 200 x 9.0 SHS	51.8	0.761	14.7	20.2	6600	39.2	392	297	465	77.1	64.5	599	1.00	23.9	C	465						
6.0 SHS	35.6	0.774	21.8	31.3	4530	28.0	280	207	327	78.6	44.8	425	1.00	37.1	N	294						
5.0 SHS	29.9	0.779	26.0	38.0	3810	23.9	239	175	277	79.1	37.8	362	0.890	45.0	S	223						
150 x 150 x 9.0 SHS	37.7	0.561	14.9	14.7	4800	15.4	205	159	248	56.6	26.1	316	1.00	17.4	C	248						
6.0 SHS	26.2	0.574	22.0	23.0	3330	11.3	150	113	178	58.2	18.4	229	1.00	27.2	C	178						
5.0 SHS	22.1	0.579	26.2	28.0	2810	9.70	129	96.1	151	58.7	15.6	197	1.00	33.1	N	144						
125 x 125 x 9.0 SHS	30.6	0.461	15.1	11.9	3900	8.38	134	106	165	46.4	14.5	208	1.00	14.1	C	165						
6.0 SHS	21.4	0.474	22.1	18.8	2730	6.29	101	76.5	120	48.0	10.4	154	1.00	22.3	C	120						
5.0 SHS	18.2	0.479	26.3	23.0	2310	5.44	87.1	65.4	103	48.5	8.87	133	1.00	27.2	C	103						
4.0 SHS	14.8	0.483	32.7	29.3	1880	4.52	72.3	53.6	84.5	49.0	7.25	110	1.00	34.6	N	78.9						
100 x 100 x 9.0 SHS	23.5	0.361	15.4	9.11	3000	3.91	78.1	63.6	98.6	36.1	7.00	123	1.00	10.8	C	98.6						
6.0 SHS	16.7	0.374	22.4	14.7	2130	3.04	60.7	47.1	73.5	37.7	5.15	93.6	1.00	17.4	C	73.5						
5.0 SHS	14.2	0.379	26.6	18.0	1810	2.66	53.1	40.5	63.5	38.3	4.42	81.4	1.00	21.3	C	63.5						
4.0 SHS	11.6	0.383	32.9	23.0	1480	2.23	44.6	33.5	52.6	38.8	3.63	68.0	1.00	27.2	C	52.6						
3.0 SHS	8.96	0.390	43.5	31.3	1140	1.77	35.4	26.0	41.2	39.4	2.79	53.2	1.00	37.1	N	37.1						
89 x 89 x 6.0 SHS	14.6	0.330	22.5	12.8	1870	2.06	46.2	36.3	56.6	33.2	3.54	71.6	1.00	15.2	C	56.6						
5.0 SHS	12.5	0.334	26.7	15.8	1590	1.81	40.7	31.4	49.1	33.7	3.05	62.7	1.00	18.7	C	49.1						
3.5 SHS	9.06	0.341	37.6	23.4	1150	1.37	30.9	23.2	36.5	34.5	2.24	47.1	1.00	27.7	C	36.5						
75 x 75 x 6.0 SHS	12.0	0.274	22.8	10.5	1530	1.16	30.9	24.7	38.4	27.5	2.04	48.2	1.00	12.4	C	38.4						
5.0 SHS	10.3	0.279	27.0	13.0	1310	1.03	27.5	21.6	33.6	28.0	1.77	42.6	1.00	15.4	C	33.6						
4.0 SHS	8.49	0.283	33.3	16.8	1080	0.882	23.5	18.0	28.2	28.6	1.48	36.1	1.00	19.8	C	28.2						
3.0 SHS	6.60	0.290	43.9	23.0	841	0.716	19.1	14.2	22.5	29.2	1.15	28.7	1.00	27.2	C	22.5						
◆ 2.5 SHS	5.56	0.291	52.4	28.0	709	0.614	16.4	12.0	19.1	29.4	0.971	24.6	1.00	33.1	N	18.3						

◆ These items are not commonly stocked but are available on indent. A minimum order quantity may apply on some sizes.

Dualgrade 350LO/450LO - please refer to page 14 'Rectangular Hollow Sections' for the 'Properties for Design to AS 4100'.

### Notes:

- This table is calculated in accordance with AS 4100 using design yield stress  $f_y = 350$  MPa and design tensile strength  $f_u = 430$  MPa as per AS 4100 table 2.1 for AS 1163 grade C350LO.
- Grade C350LO is cold-formed and therefore is allocated the CF residual-stresses classification in AS 4100.
- C = compact section; N = non-compact section; S = slender section; as defined in AS 4100.
- For square hollow sections (SHS) the outside corner radius  $r$  used in calculating the section properties is equal to  $2t$  for sections with thickness  $t \leq 3.0$ mm and  $2.5t$  for sections with  $t > 3.0$ mm.

# SQUARE HOLLOW SECTIONS

## DIMENSIONS AND PROPERTIES GRADE C350LO AS/NZS 1163

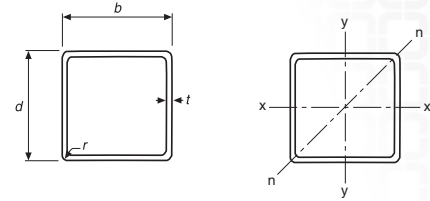

DIMENSIONS AND RATIOS						PROPERTIES						PROPERTIES FOR DESIGN TO AS 4100					
Designation			Mass per metre	External surface area		Gross section area (b-2t) t	About x-, y- and n-axis					Torsion constant J	Torsion modulus C	Form factor k <sub>f</sub>	About x- and y-axis		
d	b	t		per m	per t		A <sub>g</sub>	I <sub>x</sub>	Z <sub>x</sub>	Z <sub>n</sub>	S <sub>x</sub>				r <sub>x</sub>	λ <sub>e</sub>	Compactness <sup>(1)</sup> (C,N,S)
mm	mm	mm	kg/m	m <sup>2</sup> /m	m <sup>2</sup> /t	mm <sup>2</sup>	10 <sup>6</sup> mm <sup>4</sup>	10 <sup>6</sup> mm <sup>3</sup>	10 <sup>6</sup> mm <sup>3</sup>	10 <sup>6</sup> mm <sup>2</sup>	mm	10 <sup>6</sup> mm <sup>4</sup>	10 <sup>6</sup> mm <sup>3</sup>				10 <sup>6</sup> mm <sup>3</sup>
65 x 65 x 6.0 SHS	10.1	0.234	23.1	8.83	1290	0.706	21.7	17.8	27.5	23.4	1.27	34.2	1.00	10.5	C	27.5	
5.0 SHS	8.75	0.239	27.3	11.0	1110	0.638	19.6	15.6	24.3	23.9	1.12	30.6	1.00	13.0	C	24.3	
4.0 SHS	7.23	0.243	33.6	14.3	921	0.552	17.0	13.2	20.6	24.5	0.939	26.2	1.00	16.9	C	20.6	
3.0 SHS	5.66	0.250	44.1	19.7	721	0.454	14.0	10.4	16.6	25.1	0.733	21.0	1.00	23.3	C	16.6	
◆ 2.5 SHS	4.78	0.251	52.6	24.0	609	0.391	12.0	8.91	14.1	25.3	0.624	18.1	1.00	28.4	C	14.1	
50 x 50 x 6.0 SHS	7.32	0.174	23.8	6.33	932	0.275	11.0	9.45	14.5	17.2	0.518	17.7	1.00	8.50	C	14.5	
5.0 SHS	6.39	0.179	27.9	8.00	814	0.257	10.3	8.51	13.2	17.8	0.469	16.3	1.00	9.47	C	13.2	
4.0 SHS	5.35	0.183	34.2	10.5	681	0.229	9.15	7.33	11.4	18.3	0.403	14.3	1.00	12.4	C	11.4	
3.0 SHS	4.25	0.190	44.7	14.7	541	0.195	7.79	5.92	9.39	19.0	0.321	11.8	1.00	17.4	C	9.39	
2.5 SHS	3.60	0.191	53.1	18.0	459	0.169	6.78	5.09	8.07	19.2	0.275	10.2	1.00	21.3	C	8.07	
1.6 SHS	2.38	0.195	81.7	29.3	303	0.117	4.68	3.44	5.46	19.6	0.185	7.03	1.00	34.6	N	5.10	
40 x 40 x 4.0 SHS	4.09	0.143	34.9	8.00	521	0.105	5.26	4.36	6.74	14.2	0.192	8.33	1.00	9.47	C	6.74	
3.0 SHS	3.30	0.150	45.3	11.3	421	0.0932	4.66	3.61	5.72	14.9	0.158	7.07	1.00	13.4	C	5.72	
2.5 SHS	2.82	0.151	53.7	14.0	359	0.0822	4.11	3.13	4.97	15.1	0.136	6.21	1.00	16.6	C	4.97	
2.0 SHS	2.31	0.153	66.4	18.0	294	0.0694	3.47	2.61	4.13	15.4	0.113	5.23	1.00	21.3	C	4.13	
35 x 35 x 4.0 SHS	3.46	0.123	35.48	6.75	441	0.06	3.68	3.16	4.86	12.1	0.121	5.94	1.00	See note ▲ below			
3.0 SHS	2.83	0.130	45.8	9.67	361	0.0595	3.40	2.67	4.23	12.8	0.102	5.18	1.00	11.4	C	4.23	
2.5 SHS	2.42	0.131	54.2	12.0	309	0.0529	3.02	2.33	3.69	13.1	0.0889	4.58	1.00	14.2	C	3.69	
25 x 25 x 3.0 SHS	1.89	0.0897	47.4	6.33	241	0.0184	1.47	1.21	1.91	8.74	0.0333	2.27	1.00	7.49	C	1.91	
2.5 SHS	1.64	0.0914	55.7	8.00	209	0.0169	1.35	1.08	1.71	8.99	0.0297	2.07	1.00	9.47	C	1.71	
2.0 SHS	1.36	0.0931	68.3	10.5	174	0.0148	1.19	0.926	1.47	9.24	0.0253	1.80	1.00	12.4	C	1.47	
◆ 1.6 SHS	1.12	0.0945	84.1	13.6	143	0.0128	1.02	0.780	1.24	9.44	0.0212	1.54	1.00	16.1	C	1.24	

◆ These items are not commonly stocked but are available on indent. A minimum order quantity may apply on some sizes.

▲ Available as Dualgrade 350LO/450LO - please refer to page 14 'Rectangular Hollow Sections' for the 'Properties for Design to AS 4100'.

### Notes:

- This table is calculated in accordance with AS 4100 using design yield stress  $f_y = 350$  MPa and design tensile strength  $f_u = 430$  MPa as per AS 4100 table 2.1 for AS 1163 grade C350LO.
- Grade C350LO is cold-formed and therefore is allocated the CF residual-stresses classification in AS 4100.
- C = compact section; N = non-compact section; S = slender section; as defined in AS 4100.
- For square hollow sections (SHS) the outside corner radius  $r$  used in calculating the section properties is equal to  $2t$  for sections with thickness  $t \leq 3.0$ mm and  $2.5t$  for sections with  $t > 3.0$ mm.

# DURAGAL SQUARE HOLLOW SECTIONS

## DIMENSIONS AND PROPERTIES GRADE C450L0 AS/NZS 1163

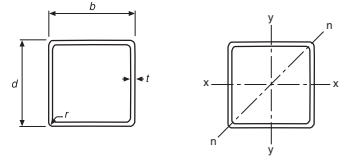

DIMENSIONS AND RATIOS				PROPERTIES										PROPERTIES FOR DESIGN TO AS 4100				
Designation	Mass per metre	External surface area		Gross section area	About x-, y- and z-axis						Torsion constant	Torsion modulus	Form factor	About x- and y-axis				
		per m	per t		(b-2t)	$I_x$	$Z_x$	$Z_y$	$S_x$	$r_x$				$J$	$C$	$k_f$	$\lambda_e$	Compactness <sup>(1)</sup>
d	b	t																
mm	mm	mm	kg/m	m <sup>2</sup> /m	m <sup>2</sup> /t	t	A <sub>g</sub>	10 <sup>4</sup> mm <sup>4</sup>	10 <sup>3</sup> mm <sup>3</sup>	10 <sup>3</sup> mm <sup>3</sup>	10 <sup>3</sup> mm <sup>3</sup>	mm	10 <sup>3</sup> mm <sup>4</sup>	10 <sup>3</sup> mm <sup>3</sup>			(C,N,S)	10 <sup>3</sup> mm <sup>3</sup>
◆ 100 x 100 x 6.0 SHS			16.7	0.374	22.4	14.7	2130	3.04	60.7	47.1	73.5	37.7	5.15	93.6	1.00	19.7	C	73.5
			14.2	0.379	26.6	18.0	1810	2.66	53.1	40.5	63.5	38.3	4.42	81.4	1.00	24.1	C	63.5
			11.6	0.383	32.9	23.0	1480	2.23	44.6	33.5	52.6	38.8	3.63	68.0	1.00	30.9	N	51.9
			8.96	0.390	43.5	31.3	1140	1.77	35.4	26.0	41.2	39.4	2.79	53.2	0.952	42.0	S	34.4
◆ 90 x 90 x 2.5 SHS			6.74	0.351	52.1	34.0	859	1.09	24.1	17.6	28.0	35.6	1.70	36.2	0.878	45.6	S	22.3
			5.45	0.353	64.8	43.0	694	0.889	19.7	14.3	22.8	35.8	1.38	29.6	0.696	57.7	S	16.0
◆ 75 x 75 x 6.0 SHS			12.0	0.274	22.8	10.5	1530	1.16	30.9	24.7	38.4	27.5	2.04	48.2	1.00	14.1	C	38.4
			10.3	0.279	27.0	13.0	1310	1.03	27.5	21.6	33.6	28.0	1.77	42.6	1.00	17.4	C	33.6
			8.49	0.283	33.3	16.8	1080	0.882	23.5	18.0	28.2	28.6	1.48	36.1	1.00	22.5	C	28.2
			6.60	0.290	43.9	23.0	841	0.716	19.1	14.2	22.5	29.2	1.15	28.7	1.00	30.9	N	22.2
			5.56	0.291	52.4	28.0	709	0.614	16.4	12.0	19.1	29.4	0.971	24.6	1.00	37.6	N	17.0
◆ 65 x 65 x 6.0 SHS			10.1	0.234	23.1	8.83	1290	0.706	21.7	17.8	27.5	23.4	1.27	34.2	1.00	11.9	C	27.5
			8.75	0.239	27.3	11.0	1110	0.638	19.6	15.6	24.3	23.9	1.12	30.6	1.00	14.8	C	24.3
			7.23	0.243	33.6	14.3	921	0.552	17.0	13.2	20.6	24.5	0.939	26.2	1.00	19.1	C	20.6
			5.66	0.250	44.1	19.7	721	0.454	14.0	10.4	16.6	25.1	0.733	21.0	1.00	26.4	C	16.6
◆ 50 x 50 x 5.0 SHS			4.78	0.251	52.6	24.0	609	0.391	12.0	8.91	14.1	25.3	0.624	18.1	1.00	32.2	N	13.7
			6.39	0.179	27.9	8.00	814	0.257	10.3	8.51	13.2	17.8	0.469	16.3	1.00	10.7	C	13.2
			5.35	0.183	34.2	10.5	681	0.229	9.15	7.33	11.4	18.3	0.403	14.3	1.00	14.1	C	11.4
			4.25	0.190	44.7	14.7	541	0.195	7.79	5.92	9.39	19.0	0.321	11.8	1.00	19.7	C	9.39
			3.60	0.191	53.1	18.0	459	0.169	6.78	5.09	8.07	19.2	0.275	10.2	1.00	24.1	C	8.07
◆ 40 x 40 x 4.0 SHS			2.38	0.195	81.7	29.3	303	0.117	4.68	3.44	5.46	19.6	0.185	7.03	1.00	39.2	N	4.74
			4.09	0.143	34.9	8.00	521	0.105	5.26	4.36	6.74	14.2	0.192	8.33	1.00	10.7	C	6.74
			3.30	0.150	45.3	11.3	421	0.0932	4.66	3.61	5.72	14.9	0.158	7.07	1.00	15.2	C	5.72
◆ 35 x 35 x 3.0 SHS			2.82	0.151	53.7	14.0	359	0.0822	4.11	3.13	4.97	15.1	0.136	6.21	1.00	18.8	C	4.97
			2.83	0.130	45.8	9.67	361	0.0595	3.40	2.67	4.23	12.8	0.102	5.18	1.00	13.0	C	4.23
			2.42	0.131	54.2	12.0	309	0.0529	3.02	2.33	3.69	13.1	0.0889	4.58	1.00	16.1	C	3.69
◆ 25 x 25 x 3.0 SHS			1.99	0.133	66.8	15.5	254	0.0451	2.58	1.95	3.09	13.3	0.0741	3.89	1.00	20.8	C	3.09
			1.63	0.135	82.7	19.9	207	0.0379	2.16	1.62	2.57	13.5	0.0611	3.26	1.00	26.7	C	2.57
◆ 25 x 25 x 3.0 SHS			1.89	0.0897	47.4	6.33	241	0.0184	1.47	1.21	1.91	8.74	0.0333	2.27	1.00	8.50	C	1.91
			1.64	0.0914	55.7	8.00	209	0.0169	1.35	1.08	1.71	8.99	0.0297	2.07	1.00	10.7	C	1.71
			1.36	0.0931	68.3	10.5	174	0.0148	1.19	0.926	1.47	9.24	0.0253	1.80	1.00	14.1	C	1.47
			1.12	0.0945	84.1	13.6	143	0.0128	1.02	0.780	1.24	9.44	0.0212	1.54	1.00	18.3	C	1.24

◆ These items are not commonly stocked but are available on indent. A minimum order quantity may apply on some sizes.

### Notes:

- This table is calculated in accordance with AS 4100 using design yield stress  $f_y = 450$  MPa and design tensile strength  $f_U = 500$  MPa as per AS 4100 table 2.1 for AS 1163 grade C450L0.
- Grade C450L0 is cold-formed and therefore is allocated the CF residual-stresses classification in AS 4100.
- C = compact section; N = non-compact section; S = slender section; as defined in AS 4100.
- For square hollow sections (SHS) the outside corner radius  $r$  used in calculating the section properties is equal to  $2t$  for sections with thickness  $t < 3.0$ mm and  $2.5t$  for sections with  $t > 3.0$ mm.
- DuraGal Dualgrade C350L0/C450L0 hollow sections have a minimum yield stress of 450 MPa ( $f_y = 450$  MPa), a minimum tensile strength of 500 MPa ( $f_U = 500$  MPa) and a minimum elongation equal to 16%, ie the strength of AS 1163 grade C450L0 and the elongation of AS 1163 grade C350L0.

• **Please Note:** Product brand name change: 'SupaGal' is now 'DuraGal'.

# LINEPIPE

## DIMENSIONS AND PROPERTIES AS/NZS 1163 GRADE C350L0

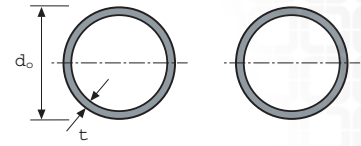

DIMENSIONS AND RATIOS						PROPERTIES					PROPERTIES FOR DESIGN TO AS 4100				
Designation		Mass per metre	External surface area		t	Gross section area $A_g$	About any axis				Torsion constant $J$	Torsion modulus $C$	$k_t$	About any axis	
$d_e$	t		per m	per t			$I$	Z	S	r				Compactness <sup>(2)</sup>	$Z_e$
mm	mm	kg/m	m <sup>2</sup> /m	m <sup>2</sup> /t	mm <sup>2</sup>	10 <sup>6</sup> mm <sup>4</sup>	10 <sup>6</sup> mm <sup>3</sup>	10 <sup>6</sup> mm <sup>3</sup>	mm	10 <sup>6</sup> mm <sup>4</sup>	10 <sup>6</sup> mm <sup>3</sup>		(C,N,S)	10 <sup>6</sup> mm <sup>3</sup>	
◆	508.0 x 12.7 CHS	155	1.60	10.3	40.0	19800	606	2390	3120	175	1210	4770	1.00	N	3050
	9.5 CHS	117	1.60	13.7	53.5	14900	462	1820	2360	176	925	3640	1.00	N	2170
◆	6.4 CHS	79.2	1.60	20.2	79.4	10100	317	1250	1610	177	634	2500	0.857	N	1290
◆	457.0 x 12.7 CHS	139	1.44	10.3	36.0	17700	438	1920	2510	157	876	3830	1.00	N	2500
	9.5 CHS	105	1.44	13.7	48.1	13400	334	1460	1900	158	669	2930	1.00	N	1790
◆	6.4 CHS	71.1	1.44	20.2	71.4	9060	230	1010	1300	159	460	2010	0.904	N	1090
◆	406.4 x 12.7 CHS	123	1.28	10.4	32.0	15700	305	1500	1970	139	609	3000	1.00	C	1970
	9.5 CHS	93.0	1.28	13.7	42.8	11800	233	1150	1500	140	467	2300	1.00	N	1450
◆	6.4 CHS	63.1	1.28	20.2	63.5	8040	161	792	1020	141	322	1580	0.960	N	895
◆	355.6 x 12.7 CHS	107	1.12	10.4	28.0	13700	201	1130	1490	121	403	2260	1.00	C	1490
	9.5 CHS	81.1	1.12	13.8	37.4	10300	155	871	1140	122	310	1740	1.00	N	1130
◆	6.4 CHS	55.1	1.12	20.3	55.6	7020	107	602	781	123	214	1200	1.00	N	710
	323.9 x 12.7 CHS	97.5	1.02	10.4	25.5	12400	151	930	1230	110	301	1860	1.00	C	1230
	9.5 CHS	73.7	1.02	13.8	34.1	9380	116	717	939	111	232	1430	1.00	C	939
	6.4 CHS	50.1	1.02	20.3	50.6	6380	80.5	497	645	112	161	994	1.00	N	601
◆	273.1 x 12.7 CHS	81.6	0.858	10.5	21.5	10400	88.3	646	862	92.2	177	1290	1.00	C	862
	9.3 CHS	60.5	0.858	14.2	29.4	7710	67.1	492	647	93.3	134	983	1.00	C	647
	6.4 CHS	42.1	0.858	20.4	42.7	5360	47.7	349	455	94.3	95.4	699	1.00	N	441
	4.8 CHS	31.8	0.858	27.0	56.9	4050	36.4	267	346	94.9	72.8	533	1.00	N	312
◆	219.1 x 8.2 CHS	42.6	0.688	16.1	26.7	5430	30.3	276	365	74.6	60.5	552	1.00	C	365
	6.4 CHS	33.6	0.688	20.5	34.2	4280	24.2	221	290	75.2	48.4	442	1.00	C	290
	4.8 CHS	25.4	0.688	27.1	45.6	3230	18.6	169	220	75.8	37.1	339	1.00	N	210
	168.3 x 7.1 CHS	28.2	0.529	18.7	23.7	3600	11.7	139	185	57.0	23.4	278	1.00	C	185
	6.4 CHS	25.6	0.529	20.7	26.3	3260	10.7	127	168	57.3	21.4	254	1.00	C	168
	4.8 CHS	19.4	0.529	27.3	35.1	2470	8.25	98.0	128	57.8	16.5	196	1.00	C	128

◆ These items are not commonly stocked but are available on indent. A minimum order quantity may apply on some sizes.

CHS = Circular hollow sections.

### Notes:

1. For grade C350L0:  $f_y = 350$  MPa and  $f_U = 430$  MPa;  $f_y$  = yield stress used in design;  $f_U$  = tensile strength used in design; as defined in AS 4100.
2. C = compact section; N = non-compact section; S = slender section; as defined in AS 4100.
3. Grade C350L0 to AS/NZS 1163 is cold-formed and is therefore allocated the CF residual-stresses classification in AS 4100.

## PLATE

There are a variety of international specifications for hot-rolled steel plate. Some of the more common specifications and grades, with their chemical and mechanical properties, are summarised below.

The chemical compositions are all the maximum % content. The mechanical properties relate to 12–20mm thick plate. These data are for comparison purposes only and should not be used in place of the actual specifications, which should always be consulted.

### MILD STEEL

STANDARD	GRADE	YIELD STRENGTH	TENSILE STRENGTH	MINIMUM ELONGATION
AS/NZ 3678:2011	G250	250MPa	410MPa	22%
AS/NZ 3678:2011	G300	300MPa	430MPa	21%

### MEDIUM TENSILE

STANDARD	GRADE	YIELD STRENGTH	TENSILE STRENGTH	MINIMUM ELONGATION
AS/NZ 3678:2011	G350	350MPa	450MPa	20%

### FLOOR (CHEQUER, TREAD)

STANDARD	GRADE	YIELD STRENGTH	TENSILE STRENGTH	MINIMUM ELONGATION
AS/NZ 1594 HA 1		Commercial grade not rated for mechanical properties		
AS/NZ 1594 HA250	G250	250MPa	350MPa	21%

### CORROSION (WEATHER RESISTANT)

STANDARD	YIELD STRENGTH	TENSILE STRENGTH	MINIMUM ELONGATION
AS/NZ 1594:2002	340MPa	450MPa	15%

### HIGH TENSILE - QUENCHED & TEMPERED

STANDARD	YIELD STRENGTH	TENSILE STRENGTH	MINIMUM ELONGATION
Welten 780E	690MPa	790-930MPa	18%

### ABRASION RESISTANT - QUENCHED & TEMPERED

STANDARD	YIELD STRENGTH	TENSILE STRENGTH	MINIMUM ELONGATION
AR400E		1350MPa	12%

### BOILER

STANDARD	YIELD STRENGTH	TENSILE STRENGTH	MINIMUM ELONGATION
AS1548-PT460	295MPa	460MPa	21%

- Weight calculation: kilograms per square metre = plate thickness (mm) x 7.85.

## COIL

Summarised below are New Zealand and international standards for Steel & Tube's common stock items. These data are for comparison purposes only and should not be used in place of the actual specifications, which should always be consulted.

### COLD ROLLED

STANDARD	PROOF STRESS YIELD POINT	TENSILE STRENGTH	MINIMUM ELONGATION	HRB
NZCC-SD I SPCC-SD	160-240	290-365 MPa	34%	40-60

### ELECTRO GALVANISED

STANDARD	COATING	TENSILE STRENGTH	MINIMUM ELONGATION	HRB
JIS G 3313 SECC	0.060Z	270MPa	34-39%	40-60
JIS G 3313 SEHC	0.060Z	270MPa	29-31%	

### ENAMELLING QUALITY

STANDARD	MINIMUM ELONGATION
JIS G3133 SP	36-40%

### ZINCALUME

STANDARD	COATING	PROOF STRESS YIELD POINT	TENSILE STRENGTH	MINIMUM ELONGATION
AS 1397 G300 AZ150	AZ150	300	340MPa	20%

### GALVANISED

STANDARD	COATING	PROOF STRESS YIELD POINT	TENSILE STRENGTH	MINIMUM ELONGATION
AS/NZ 1397 G250 Z275	Z275	250	320MPa	25%
AS/NZ 1397 G250 Z400	Z400	250	320MPa	25%
AS/NZ 1397 G250 Z600	Z600	250	320MPa	25%

### HOT ROLLED

STANDARD	PROOF STRESS YIELD POINT	TENSILE STRENGTH	MINIMUM ELONGATION
AS/NZ 1594 HA250	250	350MPa	22%

### ALUMINISED

STANDARD	COATING
ASTM A463 CQ T1-25	T1-25

## REINFORCING ROUNDS AND MESH

Pacific Steel ([www.pacificsteel.co.nz](http://www.pacificsteel.co.nz)), New Zealand's only producer of hot-rolled reinforcing steel, has a reinforcing bar range that complies with the standard AS/NZS 4671: 2001 Steel Reinforcing Material. There are two grades of steel reinforcing bar designated Seismic 300® and Seismic 500®. Pacific Steel manufactures a Seismic 500E® bar through two different manufacturing methods.

### CHEMICAL AND MECHANICAL PROPERTIES

STEEL GRADE	CARBON EQUIVALENT	CARBON %	SULPHUR & PHOS %	YIELD STRENGTH MPA*	TENSILE STRENGTH RATIO*		ELONGATION %*
	MAX	MAX	MAX	MIN	MIN	MAX	MIN
Grade 300E	0.43	0.22	0.05	300-380	1.15	1.50	15 (uniform)
Seismic 500E MA®	0.49	0.22	0.05	500-600	1.15	1.40	10 (uniform)
Reid Bar 500E MA	0.49	0.22	0.05	500-600	1.15	1.40	10 (uniform)

\* Characteristic values

### DIMENSIONAL REQUIREMENT TABLE

BAR DESIGNATION		NORMAL DIMENSIONS			MASS KG/M
PLAIN	DEFORMED	DIAMETER MM	AREA MM <sup>2</sup>	PERIMETER MM	
R6		6	28.3	18.8	0.222
R10	D10	10	78.5	31.4	0.617
R12	D12	12	113.0	37.7	0.888
R16	D16	16	201.0	50.3	1.578
R20	D20	20	314.0	62.8	2.466
R25	D25	25	491.0	78.5	3.85
	D28	28	616.0	88.0	4.834
	D32	32	804.0	101.0	6.313
	D40	40	1260.0	126.0	9.865

### HANDLING CHARACTERISTICS

	SEISMIC 500E MA®
Rebending	Yes – with preheating and following correct procedure.
Welding	Yes – following correct procedure.
Threading	Yes – loss of strength proportional to loss of cross-sectional area.
Certified to AS/NZS 4671	Yes – long-term quality assured.

### MANUFACTURING PROCESS

Seismic 500E MA® – this is a bar manufactured by the microalloy process where vanadium is added to the bar to give strength and ductility. By following the correct procedure a microalloy bar can be rebent, welded, threaded or galvanised without changing the mechanical properties of the bar. The bar itself can be recognised by its deformations and the words Seismic 500E MA.

### MESH SEISMIC AS/NZS 4671:2001

SEISMIC SE	WIRE SIZE	MASS	CROSS-SECTIONAL AREA	YIELD STRESS (± 500MPA)	MINIMUM WELD SHEAR
SE62	6.1mm	2.294 kg/m <sup>2</sup>	146 mm <sup>2</sup> /m width	73 kN/m width	743 kg force
SE62res	6.1mm	2.294 kg/m <sup>2</sup>	146 mm <sup>2</sup> /m width	73 kN/m width	743 kg force
SE72	7.0mm	3.020 kg/m <sup>2</sup>	192 mm <sup>2</sup> /m width	96 kN/m width	982 kg force
SE82	8.0mm	3.946 kg/m <sup>2</sup>	251 mm <sup>2</sup> /m width	125 kN/m width	1282 kg force
SE92	9.0mm	4.994 kg/m <sup>2</sup>	318 mm <sup>2</sup> /m width	159 kN/m width	1623 kg force

Standard sheet size is 2440mm x 6100mm (12.76m<sup>2</sup> effective cover) with SE62res sheet size being 2440mm x 4900mm (10.12 m<sup>2</sup> effective cover). Minimum uniform elongation = 10%. Ratio Ultimate/Yield: 115%–140%.

### SEISMIC SE LAP

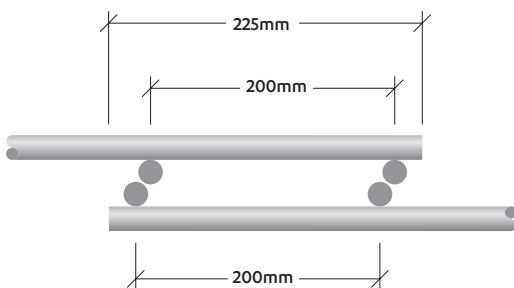

### SEISMIC SE DIAMETER AND SPACING

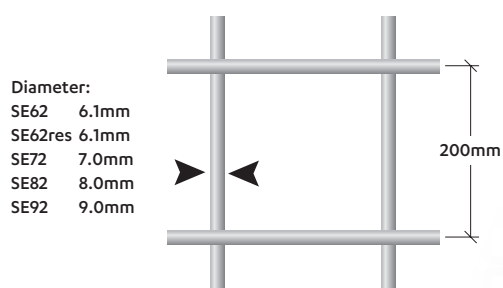

### MESH SEISMIC

STANDARD	GRADE	YIELD STRESS	ULTIMATE YIELD RATIO	UNIFORM ELONGATION	WELD SHEAR
AS/NZ 4671:2001	MA G500E	500MPA	115%	10%	50%



# DURAGAL EQUAL ANGLES

## X- AND Y-AXES DIMENSIONS AND FULL SECTION PROPERTIES AS/NZS 4600

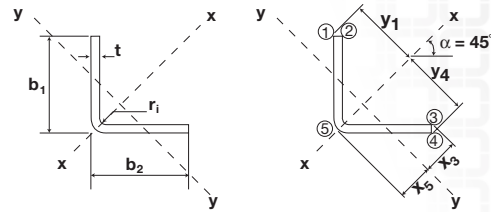

Designation Leg Size b <sub>1</sub> b <sub>2</sub>	Nominal thickness	DIMENSIONS						SECTION PROPERTIES									
		Mass per metre	Actual thickness t	Inside corner radius r <sub>i</sub>	Coordinates of centroid			Full area of section A <sub>f</sub>	About x-axis				About y-axis				
					Y <sub>1</sub> =Y <sub>4</sub>	X <sub>2</sub> =X <sub>3</sub>	X <sub>5</sub>		I <sub>x</sub>	Z <sub>x1</sub> =Z <sub>x4</sub>	S <sub>x</sub>	r <sub>x</sub>	I <sub>y</sub>	Z <sub>y2</sub> =Z <sub>y3</sub>	Z <sub>y5</sub>	S <sub>y</sub>	r <sub>y</sub>
mm	mm	kg/m	mm	mm	mm	mm	mm	mm <sup>2</sup>	10 <sup>6</sup> mm <sup>4</sup>	10 <sup>3</sup> mm <sup>3</sup>	10 <sup>3</sup> mm <sup>3</sup>	mm	10 <sup>6</sup> mm <sup>4</sup>	10 <sup>3</sup> mm <sup>3</sup>	10 <sup>3</sup> mm <sup>3</sup>	10 <sup>3</sup> mm <sup>3</sup>	mm
◆ 150 x 150 x 8.0 CA	18.0	8.0	8.0	106	53.5	51.6	2290	8.30	78.3	120	60.2	1.96	36.7	38.1	58.2	29.3	
◆ 5.0 CA	10.8	4.7	4.0	106	53.4	52.4	1380	5.04	47.6	72.4	60.6	1.23	23.0	23.4	35.6	29.9	
◆ 125 x 125 x 8.0 CA	14.9	8.0	8.0	88.4	44.6	42.8	1890	4.73	53.5	82.7	50.0	1.11	24.7	25.8	39.6	24.1	
◆ 5.0 CA	8.95	4.7	4.0	88.4	44.5	43.6	1140	2.89	32.7	50.0	50.4	0.699	15.7	16.0	24.4	24.8	
◆ 4.0 CA	7.27	3.8	4.0	88.4	44.4	43.4	926	2.36	26.7	40.7	50.5	0.572	12.9	13.2	19.9	24.9	
100 x 100 x 8.0 CA	11.7	8.0	8.0	70.7	35.8	33.9	1490	2.36	33.4	52.0	39.8	0.542	15.1	16.0	24.7	19.0	
6.0 CA	8.92	6.0	8.0	70.7	35.5	33.6	1140	1.83	25.8	39.8	40.1	0.421	11.9	12.5	19.0	19.3	
◆ 90 x 90 x 8.0 CA	10.5	8.0	8.0	63.6	32.3	30.4	1330	1.70	26.7	41.7	35.7	0.386	12.0	12.7	19.7	17.0	
◆ 5.0 CA	6.37	4.7	4.0	63.6	32.2	31.2	811	1.06	16.6	25.5	36.1	0.252	7.83	8.06	12.4	17.6	

◆ These items are not commonly stocked but are available on indent. A minimum order quantity may apply on some sizes.

CA = Cold-formed angle.

### Notes:

- Steel grade C450L0/C400L0/C350L0 (for  $t \leq 2.5$  mm  $f_y = 350$  MPa and  $f_U = 400$  MPa, for  $2.5$  mm  $< t \leq 6.0$  mm  $f_y = 450$  MPa and  $f_U = 500$  MPa, and for  $t > 6.0$  mm  $f_y = 400$  MPa and  $f_U = 450$  MPa).

# DURAGAL EQUAL ANGLES

## X- AND Y-AXES DIMENSIONS AND FULL SECTION PROPERTIES AS/NZS 4600

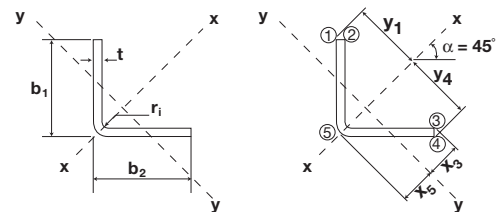

Designation Leg Size b <sub>1</sub> b <sub>2</sub>	Nominal thickness	DIMENSIONS						SECTION PROPERTIES									
		Mass per metre	Actual thickness t	Inside corner radius r <sub>i</sub>	Coordinates of centroid			Full area of section A <sub>f</sub>	About x-axis				About y-axis				
					Y <sub>1</sub> =Y <sub>4</sub>	X <sub>2</sub> =X <sub>3</sub>	X <sub>5</sub>		I <sub>x</sub>	Z <sub>x1</sub> =Z <sub>x4</sub>	S <sub>x</sub>	r <sub>x</sub>	I <sub>y</sub>	Z <sub>y2</sub> =Z <sub>y3</sub>	Z <sub>y5</sub>	S <sub>y</sub>	r <sub>y</sub>
mm	mm	kg/m	mm	mm	mm	mm	mm	mm <sup>2</sup>	10 <sup>6</sup> mm <sup>4</sup>	10 <sup>3</sup> mm <sup>3</sup>	10 <sup>3</sup> mm <sup>3</sup>	mm	10 <sup>6</sup> mm <sup>4</sup>	10 <sup>3</sup> mm <sup>3</sup>	10 <sup>3</sup> mm <sup>3</sup>	10 <sup>3</sup> mm <sup>3</sup>	mm
◆ 75 x 75 x 8.0 CA	8.59	8.0	8.0	53.0	26.9	25.1	1090	0.957	18.0	28.4	29.6	0.213	7.89	8.46	13.2	13.9	
6.0 CA	6.56	6.0	8.0	53.0	26.7	24.8	836	0.747	14.1	21.9	29.9	0.167	6.26	6.73	10.2	14.1	
5.0 CA	5.26	4.7	4.0	53.0	26.8	25.9	670	0.601	11.3	17.5	30.0	0.142	5.29	5.48	8.44	14.6	
4.0 CA	4.29	3.8	4.0	53.0	26.7	25.8	546	0.495	9.34	14.3	30.1	0.117	4.39	4.55	6.93	14.7	
65 x 65 x 6.0 CA	5.62	6.0	8.0	46.0	23.1	21.3	716	0.477	10.4	16.2	25.8	0.104	4.52	4.91	7.50	12.1	
5.0 CA	4.52	4.7	4.0	46.0	23.3	22.4	576	0.386	8.39	13.0	25.9	0.0902	3.87	4.03	6.24	12.5	
4.0 CA	3.69	3.8	4.0	46.0	23.2	22.2	470	0.318	6.93	10.7	26.0	0.0747	3.22	3.36	5.13	12.6	
50 x 50 x 6.0 CA	4.21	6.0	8.0	35.4	17.8	16.0	536	0.208	5.89	9.29	19.7	0.0434	2.44	2.71	4.18	9.00	
5.0 CA	3.42	4.7	4.0	35.4	18.0	17.1	435	0.170	4.80	7.53	19.8	0.0389	2.16	2.28	3.56	9.45	
4.0 CA	2.79	3.8	4.0	35.4	17.9	16.9	356	0.141	3.99	6.20	19.9	0.0324	1.81	1.91	2.94	9.54	
2.5 CA	1.81	2.4	2.5	35.4	17.8	17.2	230	0.0930	2.63	4.04	20.1	0.0221	1.24	1.28	1.95	9.79	
◆ 45 x 45 x 4.0 CA	2.50	3.8	4.0	31.8	16.1	15.2	318	0.102	3.19	4.98	17.9	0.0231	1.43	1.52	2.35	8.52	
◆ 2.5 CA	1.62	2.4	2.5	31.8	16.0	15.4	206	0.0673	2.11	3.25	18.1	0.0159	0.990	1.03	1.57	8.77	
40 x 40 x 4.0 CA	2.20	3.8	4.0	28.3	14.3	13.4	280	0.0702	2.48	3.89	15.8	0.0157	1.10	1.17	1.82	7.50	
2.5 CA	1.43	2.4	2.5	28.3	14.3	13.7	182	0.0468	1.65	2.55	16.0	0.0110	0.768	0.801	1.22	7.75	
30 x 30 x 2.5 CA	1.06	2.4	2.5	21.2	10.7	10.2	134	0.0191	0.902	1.40	11.9	0.00438	0.408	0.431	0.664	5.71	

◆ These items are not commonly stocked but are available on indent. A minimum order quantity may apply on some sizes.

### Notes:

- Steel grade C450L0/C400L0/C350L0 (for  $t \leq 2.5$  mm  $f_y = 350$  MPa and  $f_U = 400$  MPa, for  $2.5$  mm  $< t \leq 6.0$  mm  $f_y = 450$  MPa and  $f_U = 500$  MPa, and for  $t > 6.0$  mm  $f_y = 400$  MPa and  $f_U = 450$  MPa).
- Full section properties are calculated in accordance with AS/NZS 4600.

# DURAGAL EQUAL ANGLES

## N- AND P-AXES DIMENSIONS AND FULL-SECTION PROPERTIES AS/NZS 4600

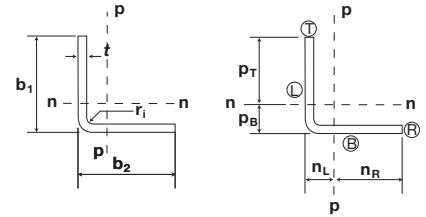

DIMENSIONS							SECTION PROPERTIES							
Leg b <sub>1</sub>	Size b <sub>2</sub>	Nominal thickness	Mass per metre	Actual thickness t	Inside corner radius r <sub>i</sub>	Coordinates of centroid		Full area of section A <sub>f</sub>	About n- and p-axes				Product of 2nd moment of area I <sub>np</sub>	
						P <sub>B</sub> =n <sub>L</sub>	P <sub>T</sub> =n <sub>R</sub>		I <sub>n</sub> =I <sub>p</sub>	Z <sub>nB</sub> =Z <sub>pL</sub>	Z <sub>nT</sub> =Z <sub>pR</sub>	S <sub>n</sub> =S <sub>p</sub>		r <sub>n</sub> =r <sub>p</sub>
mm	mm	mm	kg/m	mm	mm	mm	mm	mm <sup>2</sup>	10 <sup>6</sup> mm <sup>4</sup>	10 <sup>3</sup> mm <sup>3</sup>	10 <sup>3</sup> mm <sup>3</sup>	10 <sup>3</sup> mm <sup>3</sup>	mm	10 <sup>6</sup> mm <sup>4</sup>
◆	150 x 150	8.0 CA	18.0	8.0	8.0	41.2	109	2290	5.13	125	47.2	85.2	47.3	-3.17
◆		5.0 CA	10.8	4.7	4.0	39.6	110	1380	3.14	79.1	28.4	51.2	47.7	-1.91
◆	125 x 125	8.0 CA	14.9	8.0	8.0	34.9	90.1	1890	2.92	83.5	32.4	58.5	39.2	-1.81
◆		5.0 CA	8.95	4.7	4.0	33.4	91.6	1140	1.80	53.8	19.6	35.3	39.7	-1.10
◆		4.0 CA	7.27	3.8	4.0	33.0	92.0	926	1.47	44.5	16.0	28.8	39.8	-0.896
	100 x 100	8.0 CA	11.7	8.0	8.0	28.7	71.3	1490	1.45	50.6	20.4	36.8	31.2	-0.910
		6.0 CA	8.92	6.0	8.0	27.9	72.1	1140	1.12	40.3	15.6	28.2	31.5	-0.703
◆	90 x 90	8.0 CA	10.5	8.0	8.0	26.2	63.8	1330	1.04	39.8	16.3	29.5	27.9	-0.657
◆		5.0 CA	6.37	4.7	4.0	24.6	65.4	811	0.654	26.6	10.0	18.0	28.4	-0.402

◆ These items are not commonly stocked but are available on indent. A minimum order quantity may apply on some sizes.

### Notes:

- Steel grade C450L0/C400L0/C350L0 (for  $t \leq 2.5$  mm  $f_y = 350$  MPa and  $f_u = 400$  MPa, for  $2.5$  mm  $< t \leq 6.0$  mm  $f_y = 450$  MPa and  $f_u = 500$  MPa, and for  $t > 6.0$  mm  $f_y = 400$  MPa and  $f_u = 450$  MPa).

# DURAGAL EQUAL ANGLES

## N- AND P-AXES DIMENSIONS AND FULL-SECTION PROPERTIES AS/NZS 4600

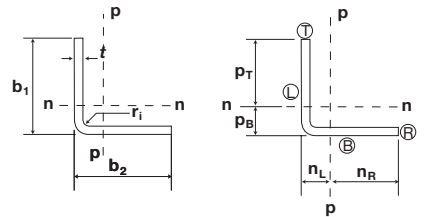

DIMENSIONS							SECTION PROPERTIES							
Leg b <sub>1</sub>	Size b <sub>2</sub>	Nominal thickness	Mass per metre	Actual thickness t	Inside corner radius r <sub>i</sub>	Coordinates of centroid		Full area of section A <sub>f</sub>	About n- and p-axes				Product of 2nd moment of area I <sub>np</sub>	
						P <sub>B</sub> =n <sub>L</sub>	P <sub>T</sub> =n <sub>R</sub>		I <sub>n</sub> =I <sub>p</sub>	Z <sub>nB</sub> =Z <sub>pL</sub>	Z <sub>nT</sub> =Z <sub>pR</sub>	S <sub>n</sub> =S <sub>p</sub>		r <sub>n</sub> =r <sub>p</sub>
mm	mm	mm	kg/m	mm	mm	mm	mm	mm <sup>2</sup>	10 <sup>6</sup> mm <sup>4</sup>	10 <sup>3</sup> mm <sup>3</sup>	10 <sup>3</sup> mm <sup>3</sup>	10 <sup>3</sup> mm <sup>3</sup>	mm	10 <sup>6</sup> mm <sup>4</sup>
◆	75 x 75	8.0 CA	8.59	8.0	8.0	22.5	52.5	1090	0.585	26.0	11.1	20.1	23.1	-0.372
		6.0 CA	6.56	6.0	8.0	21.7	53.3	836	0.457	21.1	8.57	15.5	23.4	-0.290
		5.0 CA	5.26	4.7	4.0	20.9	54.1	670	0.372	17.8	6.86	12.4	23.5	-0.230
		4.0 CA	4.29	3.8	4.0	20.5	54.5	546	0.306	14.9	5.62	10.1	23.7	-0.189
	65 x 65	6.0 CA	5.62	6.0	8.0	19.2	45.8	716	0.291	15.2	6.35	11.5	20.2	-0.186
		5.0 CA	4.52	4.7	4.0	18.4	46.6	576	0.238	13.0	5.10	9.22	20.3	-0.148
		4.0 CA	3.69	3.8	4.0	18.0	47.0	470	0.197	10.9	4.18	7.56	20.5	-0.122
	50 x 50	6.0 CA	4.21	6.0	8.0	15.4	34.6	536	0.126	8.15	3.64	6.59	15.3	-0.0823
		5.0 CA	3.42	4.7	4.0	14.6	35.4	435	0.104	7.14	2.95	5.33	15.5	-0.0655
		4.0 CA	2.79	3.8	4.0	14.3	35.7	356	0.0868	6.08	2.43	4.39	15.6	-0.0544
		2.5 CA	1.81	2.4	2.5	13.6	36.4	230	0.0576	4.23	1.58	2.86	15.8	-0.0355
◆	45 x 45	4.0 CA	2.50	3.8	4.0	13.0	32.0	318	0.0623	4.79	1.95	3.52	14.0	-0.0392
◆		2.5 CA	1.62	2.4	2.5	12.4	32.6	206	0.0416	3.36	1.27	2.30	14.2	-0.0257
	40 x 40	4.0 CA	2.20	3.8	4.0	11.8	28.2	280	0.0430	3.65	1.52	2.75	12.4	-0.0272
		2.5 CA	1.43	2.4	2.5	11.1	28.9	182	0.0289	2.60	0.999	1.80	12.6	-0.0179
	30 x 30	2.5 CA	1.06	2.4	2.5	8.61	21.4	134	0.0118	1.37	0.550	0.994	9.35	-0.00738

◆ These items are not commonly stocked but are available on indent. A minimum order quantity may apply on some sizes.

### Notes:

- Steel grade C450L0/C400L0/C350L0 (for  $t \leq 2.5$  mm  $f_y = 350$  MPa and  $f_u = 400$  MPa, for  $2.5$  mm  $< t \leq 6.0$  mm  $f_y = 450$  MPa and  $f_u = 500$  MPa, and for  $t > 6.0$  mm  $f_y = 400$  MPa and  $f_u = 450$  MPa).

# DURAGAL EQUAL ANGLES

## X- AND Y-AXES EFFECTIVE SECTION PROPERTIES AS/NZS 4600

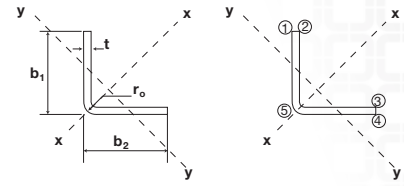

DIMENSIONS					RATIOS		GRADE		EFFECTIVE SECTION PROPERTIES							
Designation		Mass per metre	Actual thickness	Outside corner radius	$\frac{b_1 - r_0}{t}$	$\frac{b_2 - r_0}{t}$	Yield stress	Effective area of section	$A_e$	About x-axis			About y-axis			
Leg Size	Nominal thickness		t	$r_0$			$f_y$	$A_e$	$A_f$	$I_{ex1} = I_{ex4}$	$Z_{ex1} = Z_{ex4}$	$I_{ey2,3}$	$Z_{ey2,3}$	$I_{ey5}$	$Z_{ey5}$	
b1	b2	thickness	mm	mm			MPa	mm <sup>2</sup>		10 <sup>6</sup> mm <sup>4</sup>	10 <sup>3</sup> mm <sup>3</sup>	10 <sup>6</sup> mm <sup>4</sup>	10 <sup>3</sup> mm <sup>3</sup>	10 <sup>6</sup> mm <sup>4</sup>	10 <sup>3</sup> mm <sup>3</sup>	
◆	150 x 150 x 8.0	CA	18.0	8.0	16.0	16.8	16.8	400	1610	0.701	5.74	60.8	1.56	31.4	1.96	36.7
◆	5.0	CA	10.8	4.7	8.7	30.1	30.1	450	572	0.416	1.99	25.3	0.544	13.2	1.23	23.0
◆	125 x 125 x 8.0	CA	14.9	8.0	16.0	13.6	13.6	400	1530	0.809	3.90	46.9	1.05	23.9	1.11	24.7
◆	5.0	CA	8.95	4.7	8.7	24.7	24.7	450	560	0.491	1.34	19.4	0.368	10.2	0.699	15.7
◆	4.0	CA	7.27	3.8	7.8	30.8	30.8	450	379	0.409	0.917	14.0	0.248	7.31	0.572	12.9
	100 x 100 x 8.0	CA	11.7	8.0	16.0	10.5	10.5	400	1410	0.946	2.36	33.4	0.542	15.1	0.542	15.1
	6.0	CA	8.92	6.0	14.0	14.3	14.3	450	859	0.756	1.38	21.3	0.363	10.7	0.421	11.9
◆	90 x 90 x 8.0	CA	10.5	8.0	16.0	9.25	9.25	400	1330	1.00	1.70	26.7	0.386	12.0	0.386	12.0
◆	5.0	CA	6.37	4.7	8.7	17.3	17.3	450	530	0.654	0.672	12.2	0.185	6.33	0.252	7.83

◆ These items are not commonly stocked but are available on indent. A minimum order quantity may apply on some sizes.

### Notes:

- Steel grade C450L0/C400L0/C350L0 (for  $t \leq 2.5$  mm  $f_y = 350$  MPa and  $f_U = 400$  MPa, for  $2.5$  mm  $< t \leq 6.0$  mm  $f_y = 450$  MPa and  $f_U = 500$  MPa, and for  $t > 6.0$  mm  $f_y = 400$  MPa and  $f_U = 450$  MPa).
- $A_e$  is calculated for sections with uniform axial compressive stress  $f_y$ .
- $I_e$  and  $Z_e$  are calculated with the extreme compression or tension fibres at  $f_y$  (first yield).  $Z_e$  is calculated at the extreme tension or compression fibre of the effective section.
- $I_{ex1}$  and  $Z_{ex1}$  are for compression at point '1';  $I_{ex4}$  and  $Z_{ex4}$  are for compression at point '4';  $I_{ey2,3}$  and  $Z_{ey2,3}$  are for compression at points '2' and '3';  $I_{ey5}$  and  $Z_{ey5}$  are for compression at point '5'.

# DURAGAL EQUAL ANGLES

## X- AND Y-AXES EFFECTIVE SECTION PROPERTIES AS/NZS 4600

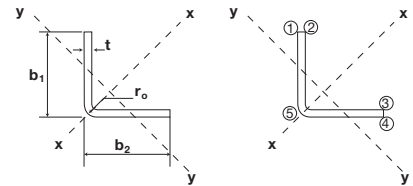

DIMENSIONS					RATIOS		GRADE		EFFECTIVE SECTION PROPERTIES							
Designation		Mass per metre	Actual thickness	Outside corner radius	$\frac{b_1 - r_0}{t}$	$\frac{b_2 - r_0}{t}$	Yield stress	Effective area of section	$A_e$	About x-axis			About y-axis			
Leg Size	Nominal thickness		t	$r_0$			$f_y$	$A_e$	$A_f$	$I_{ex1} = I_{ex4}$	$Z_{ex1} = Z_{ex4}$	$I_{ey2,3}$	$Z_{ey2,3}$	$I_{ey5}$	$Z_{ey5}$	
b1	b2	thickness	mm	mm			MPa	mm <sup>2</sup>		10 <sup>6</sup> mm <sup>4</sup>	10 <sup>3</sup> mm <sup>3</sup>	10 <sup>6</sup> mm <sup>4</sup>	10 <sup>3</sup> mm <sup>3</sup>	10 <sup>6</sup> mm <sup>4</sup>	10 <sup>3</sup> mm <sup>3</sup>	
◆	75 x 75 x 8.0	CA	8.59	8.0	16.0	7.38	7.38	400	1090	1.00	0.957	18.0	0.213	7.89	0.213	7.89
	6.0	CA	6.56	6.0	14.0	10.2	10.2	450	781	0.934	0.735	13.9	0.167	6.26	0.167	6.26
	5.0	CA	5.26	4.7	8.7	14.1	14.1	450	508	0.759	0.458	9.41	0.125	4.84	0.142	5.29
	4.0	CA	4.29	3.8	7.8	17.7	17.7	450	353	0.646	0.310	6.78	0.0840	3.49	0.117	4.39
	65 x 65 x 6.0	CA	5.62	6.0	14.0	8.50	8.5	450	716	1.00	0.477	10.4	0.104	4.52	0.104	4.52
	5.0	CA	4.52	4.7	8.7	12.0	12.0	450	487	0.846	0.337	7.65	0.0902	3.87	0.0902	3.87
	4.0	CA	3.69	3.8	7.8	15.1	15.1	450	342	0.727	0.230	5.54	0.0619	2.83	0.0747	3.22
	50 x 50 x 6.0	CA	4.21	6.0	14.0	6.00	6.00	450	536	1.00	0.208	5.89	0.0434	2.44	0.0434	2.44
	5.0	CA	3.42	4.7	8.7	8.79	8.79	450	435	1.00	0.170	4.80	0.0389	2.16	0.0389	2.16
	4.0	CA	2.79	3.8	7.8	11.1	11.1	450	316	0.888	0.131	3.78	0.0324	1.81	0.0324	1.81
	2.5	CA	1.81	2.4	4.9	18.8	18.8	350	156	0.676	0.0615	1.98	0.0169	1.03	0.0221	1.24
◆	45 x 45 x 4.0	CA	2.50	3.8	7.8	9.79	9.79	450	303	0.952	0.102	3.19	0.0231	1.43	0.0231	1.43
◆	2.5	CA	1.62	2.4	4.9	16.7	16.7	350	152	0.736	0.0494	1.71	0.0135	0.884	0.0159	0.990
	40 x 40 x 4.0	CA	2.20	3.8	7.8	8.47	8.47	450	280	1.00	0.0702	2.48	0.0157	1.10	0.0157	1.10
	2.5	CA	1.43	2.4	4.9	14.6	14.6	350	147	0.806	0.0385	1.45	0.0104	0.740	0.0110	0.768
	30 x 30 x 2.5	CA	1.06	2.4	4.9	10.5	10.5	350	132	0.980	0.0191	0.902	0.00438	0.408	0.00438	0.408

◆ These items are not commonly stocked but are available on indent. A minimum order quantity may apply on some sizes.

### Notes:

- Steel grade C450L0/C400L0/C350L0 (for  $t \leq 2.5$  mm  $f_y = 350$  MPa and  $f_U = 400$  MPa, for  $2.5$  mm  $< t \leq 6.0$  mm  $f_y = 450$  MPa and  $f_U = 500$  MPa, and for  $t > 6.0$  mm  $f_y = 400$  MPa and  $f_U = 450$  MPa).
- $A_e$  is calculated for sections with uniform axial compressive stress  $f_y$ .
- $I_e$  and  $Z_e$  are calculated with the extreme compression or tension fibres at  $f_y$  (first yield).  $Z_e$  is calculated at the extreme tension or compression fibre of the effective section.
- $I_{ex1}$  and  $Z_{ex1}$  are for compression at point '1';  $I_{ex4}$  and  $Z_{ex4}$  are for compression at point '4';  $I_{ey2,3}$  and  $Z_{ey2,3}$  are for compression at points '2' and '3';  $I_{ey5}$  and  $Z_{ey5}$  are for compression at point '5'.

# DURAGAL EQUAL ANGLES

## N- AND P-AXES EFFECTIVE SECTION PROPERTIES AS/NZS 4600

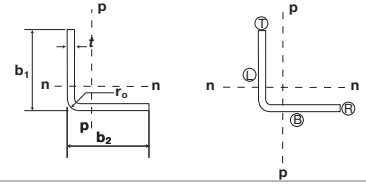

Designation			DIMENSIONS			RATIOS		GRADE			EFFECTIVE SECTION PROPERTIES			
Leg Size	Nominal thickness	Mass per metre	Actual thickness	Outside corner radius	$\frac{b_1 - r_o}{t}$	$\frac{b_2 - r_o}{t}$	Yield stress	Effective area of section	$\frac{A_e}{A_f}$	About n- and p-axis				
b <sub>1</sub>	b <sub>2</sub>	kg/m	t	r <sub>o</sub>						$f_y$	A <sub>e</sub>	A <sub>f</sub>	$I_{enT} = I_{epR}$	$Z_{enT} = Z_{epR}$
mm	mm	mm	mm	mm			MPa	mm <sup>2</sup>		10 <sup>6</sup> mm <sup>4</sup>	10 <sup>3</sup> mm <sup>3</sup>	10 <sup>6</sup> mm <sup>4</sup>	10 <sup>3</sup> mm <sup>3</sup>	
◆ 150 x 150 x 8.0 CA		18.0	8.0	16.0	16.8	16.8	400	1610	0.701	3.17	33.8	5.04	46.8	
◆	5.0 CA	10.8	4.7	8.7	30.1	30.1	450	572	0.416	0.791	11.0	2.57	25.9	
◆ 125 x 125 x 8.0 CA		14.9	8.0	16.0	13.6	13.6	400	1530	0.809	2.34	27.8	2.92	32.4	
◆	5.0 CA	8.95	4.7	8.7	24.7	24.7	450	560	0.491	0.594	9.13	1.57	18.4	
◆	4.0 CA	7.27	3.8	7.8	30.8	30.8	450	379	0.409	0.357	6.01	1.20	14.5	
100 x 100 x 8.0 CA		11.7	8.0	16.0	10.5	10.5	400	1410	0.946	1.45	20.4	1.45	20.4	
	6.0 CA	8.92	6.0	14.0	14.3	14.3	450	859	0.756	0.782	12.1	1.12	15.6	
◆ 90 x 90 x 8.0 CA		10.5	8.0	16.0	9.25	9.25	400	1330	1.00	1.04	16.3	1.04	16.3	
◆	5.0 CA	6.37	4.7	8.7	17.3	17.3	450	530	0.654	0.357	6.58	0.629	9.83	

◆ These items are not commonly stocked but are available on indent. A minimum order quantity may apply on some sizes.

### Notes:

- Steel grade C450L0 / C400L0 / C350L0 (for  $t \leq 2.5\text{mm}$   $f_y = 350\text{ MPa}$  and  $f_u = 400\text{ MPa}$ , for  $2.5\text{mm} < t \leq 6.0\text{mm}$   $f_y = 450\text{ MPa}$  and  $f_u = 500\text{ MPa}$ , and for  $t > 6.0\text{mm}$   $f_y = 400\text{ MPa}$  and  $f_u = 450\text{ MPa}$ ).
- $A_e$  is calculated for sections with uniform axial compressive stress  $f_y$ .
- $I_e$  and  $Z_e$  are calculated with the extreme compression or tension fibres at  $f_y$  (first yield).  $Z_e$  is calculated at the extreme tension or compression fibre of the effective section.
- $I_{enT}$  and  $Z_{enT}$  are for compression at point 'T';  $I_{enB}$  and  $Z_{enB}$  are for compression at point 'B';  $I_{epR}$  and  $Z_{epR}$  are for compression at point 'R';  $I_{epL}$  and  $Z_{epL}$  are for compression at point 'L'.

# DURAGAL EQUAL ANGLES

## N- AND P-AXES EFFECTIVE SECTION PROPERTIES AS/NZS 4600

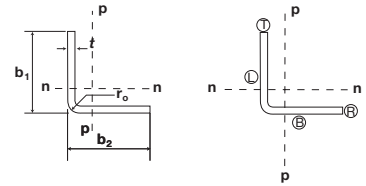

Designation			DIMENSIONS			RATIOS		GRADE			EFFECTIVE SECTION PROPERTIES			
Leg Size	Nominal thickness	Mass per metre	Actual thickness	Outside corner radius	$\frac{b_1 - r_o}{t}$	$\frac{b_2 - r_o}{t}$	Yield stress	Effective area of section	$\frac{A_e}{A_f}$	About n- and p-axis				
b <sub>1</sub>	b <sub>2</sub>	kg/m	t	r <sub>o</sub>						$f_y$	A <sub>e</sub>	A <sub>f</sub>	$I_{enT} = I_{epR}$	$Z_{enT} = Z_{epR}$
mm	mm	mm	mm	mm			MPa	mm <sup>2</sup>		10 <sup>6</sup> mm <sup>4</sup>	10 <sup>3</sup> mm <sup>3</sup>	10 <sup>6</sup> mm <sup>4</sup>	10 <sup>3</sup> mm <sup>3</sup>	
◆ 75 x 75 x 8.0 CA		8.59	8.0	16.0	7.38	7.38	400	1090	1.00	0.585	11.1	0.585	11.1	
	6.0 CA	6.56	6.0	14.0	10.2	10.2	450	781	0.934	0.457	8.57	0.457	8.57	
	5.0 CA	5.26	4.7	8.7	14.1	14.1	450	508	0.759	0.266	5.45	0.372	6.86	
	4.0 CA	4.29	3.8	7.8	17.7	17.7	450	353	0.646	0.162	3.62	0.293	5.51	
65 x 65 x 6.0 CA		5.62	6.0	14.0	8.50	8.5	450	716	1.00	0.291	6.35	0.291	6.35	
	5.0 CA	4.52	4.7	8.7	12.0	12.0	450	487	0.846	0.208	4.65	0.238	5.10	
	4.0 CA	3.69	3.8	7.8	15.1	15.1	450	342	0.727	0.129	3.13	0.195	4.17	
50 x 50 x 6.0 CA		4.21	6.0	14.0	6.00	6.00	450	536	1.00	0.126	3.64	0.126	3.64	
	5.0 CA	3.42	4.7	8.7	8.79	8.79	450	435	1.00	0.104	2.95	0.104	2.95	
	4.0 CA	2.79	3.8	7.8	11.1	11.1	450	316	0.888	0.0821	2.34	0.0868	2.43	
	2.5 CA	1.81	2.4	4.9	18.8	18.8	350	156	0.676	0.0333	1.08	0.0560	1.56	
◆ 45 x 45 x 4.0 CA		2.50	3.8	7.8	9.79	9.79	450	303	0.952	0.0623	1.95	0.0623	1.95	
◆	2.5 CA	1.62	2.4	4.9	16.7	16.7	350	152	0.736	0.0281	0.972	0.0414	1.27	
40 x 40 x 4.0 CA		2.20	3.8	7.8	8.47	8.47	450	280	1.00	0.0430	1.52	0.0430	1.52	
	2.5 CA	1.43	2.4	4.9	14.6	14.6	350	147	0.806	0.0231	0.856	0.0289	0.999	
30 x 30 x 2.5 CA		1.06	2.4	4.9	10.5	10.5	350	132	0.980	0.0118	0.550	0.0118	0.550	

◆ These items are not commonly stocked but are available on indent. A minimum order quantity may apply on some sizes.

### Notes:

- Steel grade C450L0 / C400L0 / C350L0 (for  $t \leq 2.5\text{mm}$   $f_y = 350\text{ MPa}$  and  $f_u = 400\text{ MPa}$ , for  $2.5\text{mm} < t \leq 6.0\text{mm}$   $f_y = 450\text{ MPa}$  and  $f_u = 500\text{ MPa}$ , and for  $t > 6.0\text{mm}$   $f_y = 400\text{ MPa}$  and  $f_u = 450\text{ MPa}$ ).
- $A_e$  is calculated for sections with uniform axial compressive stress  $f_y$ .
- $I_e$  and  $Z_e$  are calculated with the extreme compression or tension fibres at  $f_y$  (first yield).  $Z_e$  is calculated at the extreme tension or compression fibre of the effective section.
- $I_{enT}$  and  $Z_{enT}$  are for compression at point 'T';  $I_{enB}$  and  $Z_{enB}$  are for compression at point 'B';  $I_{epR}$  and  $Z_{epR}$  are for compression at point 'R';  $I_{epL}$  and  $Z_{epL}$  are for compression at point 'L'.

# DURAGAL EQUAL ANGLES

## X- AND Y-AXES SECTION PROPERTIES FOR MEMBER STABILITY AS/NZS 4600

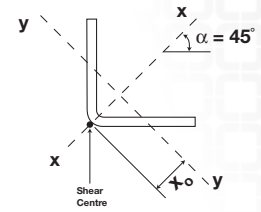

Designation			Mass per metre	Torsion constant	Coordinate of shear centre	Polar radius of gyration about the shear centre	Monosymmetry section constant
Leg Size	$b_1$	Nominal thickness					
mm	mm	mm	kg/m	$10^3 \text{mm}^4$	mm	mm	mm
◆	150 x 150	8.0 CA	18.0	49.0	51.6	84.3	206
◆		5.0 CA	10.8	10.1	52.2	85.2	209
◆	125 x 125	8.0 CA	14.9	40.4	42.8	69.9	171
◆		5.0 CA	8.95	8.39	43.4	70.8	173
◆		4.0 CA	7.27	4.46	43.5	71.1	174
	100 x 100	8.0 CA	11.7	31.9	33.9	55.4	136
		6.0 CA	8.92	13.6	34.3	56.0	137
◆	90 x 90	8.0 CA	10.5	28.5	30.4	49.7	122
◆		5.0 CA	6.37	5.97	31.0	50.6	124
	75 x 75	8.0 CA	8.59	23.4	25.1	41.0	100
		6.0 CA	6.56	10.0	25.5	41.6	102
		5.0 CA	5.26	4.93	25.7	41.9	103
		4.0 CA	4.29	2.63	25.8	42.2	103
	65 x 65	6.0 CA	5.62	8.59	21.9	35.8	87.7
		5.0 CA	4.52	4.24	22.2	36.2	88.6
		4.0 CA	3.69	2.26	22.3	36.4	89.2
	50 x 50	6.0 CA	4.21	6.43	16.6	27.1	66.5
		5.0 CA	3.42	3.20	16.8	27.5	67.4
		4.0 CA	2.79	1.71	17.0	27.8	68.0
		2.5 CA	1.81	0.442	17.3	28.2	69.0
◆	45 x 45	4.0 CA	2.50	1.53	15.2	24.9	61.0
◆		2.5 CA	1.62	0.396	15.5	25.3	61.9
	40 x 40	4.0 CA	2.20	1.35	13.5	22.0	53.9
		2.5 CA	1.43	0.350	13.7	22.4	54.9
	30 x 30	2.5 CA	1.06	0.258	10.2	16.6	40.7

◆ These items are not commonly stocked but are available on indent. A minimum order quantity may apply on some sizes.

### Notes:

- Steel grade C450L0/C400L0/C350L0 (for  $t \leq 2.5 \text{ mm}$   $f_y = 350 \text{ MPa}$  and  $f_u = 400 \text{ MPa}$ , for  $2.5 \text{ mm} < t \leq 6.0 \text{ mm}$   $f_y = 450 \text{ MPa}$  and  $f_u = 500 \text{ MPa}$ , and for  $t > 6.0 \text{ mm}$   $f_y = 400 \text{ MPa}$  and  $f_u = 450 \text{ MPa}$ ).
- With the exception of  $J$ , properties are calculated assuming a simplified shape where the bends are eliminated and the section is represented by straight mid-lines in accordance with Clause 2.1.2.1 of AS/NZS 4600.
- $\beta_x$  is zero for equal angles.
- $I_w$  is equal to zero for angles.
- The shear centre is assumed to be located at the intersection of the centre lines of the angle legs.

# DURAGAL CHANNELS

## X- AND Y-AXES DIMENSIONS AND FULL SECTION PROPERTIES AS/NZS 4600

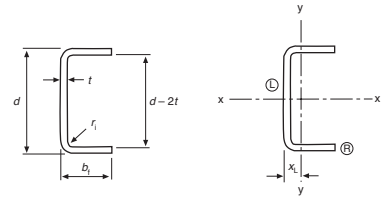

DIMENSIONS									SECTION PROPERTIES									
Designation	Mass per metre	Actual thickness t	Inside corner radius r <sub>i</sub>	Depth between flanges d - 2t	Coordinates of centroid x <sub>L</sub>	Full area of section A <sub>f</sub>	About x-axis				About y-axis							
							I <sub>x</sub>	Z <sub>x</sub>	S <sub>x</sub>	r <sub>x</sub>	I <sub>y</sub>	Z <sub>yR</sub>	Z <sub>yL</sub>	S <sub>y</sub>	r <sub>y</sub>			
d	b <sub>f</sub>	Nominal thickness	mm	mm	mm	mm	10 <sup>6</sup> mm <sup>4</sup>	10 <sup>3</sup> mm <sup>3</sup>	10 <sup>3</sup> mm <sup>3</sup>	mm	10 <sup>6</sup> mm <sup>4</sup>	10 <sup>3</sup> mm <sup>3</sup>	10 <sup>3</sup> mm <sup>3</sup>	10 <sup>3</sup> mm <sup>3</sup>	mm			
◆ 300 x 90 x 8.0 CC	28.5	8.0	8.0	284	20.3	3630	44.2	294	359	110	2.44	35.0	120	62.1	25.9			
6.0 CC	21.6	6.0	8.0	288	19.5	2750	34.0	227	275	111	1.89	26.8	96.6	47.1	26.2			
250 x 90 x 6.0 CC	19.2	6.0	8.0	238	21.6	2450	21.9	176	210	94.6	1.79	26.2	83.3	46.4	27.1			
◆ 230 x 75 x 6.0 CC	16.9	6.0	8.0	218	17.5	2150	15.7	137	166	85.5	1.05	18.2	59.8	32.2	22.0			
200 x 75 x 6.0 CC	15.5	6.0	8.0	188	18.8	1970	11.2	112	135	75.5	1.00	17.9	53.4	31.8	22.6			
◆ 5.0 CC	12.4	4.7	4.0	191	18.1	1580	9.18	91.8	109	76.4	0.812	14.3	44.9	25.3	22.7			
180 x 75 x 5.0 CC	11.6	4.7	4.0	171	19.1	1480	7.16	79.5	93.7	69.5	0.787	14.1	41.2	25.1	23.1			
150 x 75 x 5.0 CC	10.5	4.7	4.0	141	20.9	1340	4.67	62.3	72.5	59.0	0.743	13.7	35.6	24.8	23.5			
125 x 65 x 4.0 CC	7.23	3.8	4.0	117	18.3	921	2.25	36.1	41.8	49.5	0.388	8.32	21.2	15.1	20.5			
100 x 50 x 4.0 CC	5.59	3.8	4.0	92.4	14.3	712	1.08	21.7	25.4	39.0	0.174	4.86	12.2	8.78	15.6			
75 x 40 x 4.0 CC	4.25	3.8	4.0	67.4	12.1	541	0.457	12.2	14.4	29.1	0.0840	3.01	6.93	5.46	12.5			

◆ These items are not commonly stocked but are available on indent. A minimum order quantity may apply on some sizes.

### Notes:

- Steel grade C450L0/C400L0 (for t < 6.0mm f<sub>y</sub> = 450 MPa and f<sub>U</sub> = 500 MPa, and for t > 6.0mm f<sub>y</sub> = 400 MPa and f<sub>U</sub> = 450 MPa).

# DURAGAL CHANNELS

## X- AND Y-AXES EFFECTIVE SECTION PROPERTIES AS/NZS 4600

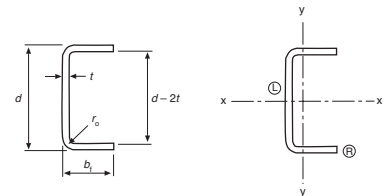

DIMENSIONS							RATIOS				GRADE		EFFECTIVE SECTION PROPERTIES					
Designation	Mass per metre	Actual thickness t	Outside corner radius r <sub>o</sub>	Depth between flanges d - 2t	(d-2r <sub>o</sub> ) / t	(b-r <sub>o</sub> ) / t	d <sub>e</sub> / (d-2r <sub>o</sub> )	b <sub>e</sub> / (b-r <sub>o</sub> )	A <sub>e</sub> / A <sub>f</sub>	Yield stress f <sub>y</sub>	Effective area of section A <sub>e</sub>	About x-axis			About y-axis			
												I <sub>ex</sub>	Z <sub>ex</sub>	I <sub>eyR</sub>	Z <sub>eyR</sub>	I <sub>eyL</sub>	Z <sub>eyL</sub>	
d	b <sub>f</sub>	Nominal thickness	mm	mm	mm	mm	mm	mm	MPa	mm <sup>2</sup>	10 <sup>6</sup> mm <sup>4</sup>	10 <sup>3</sup> mm <sup>3</sup>	10 <sup>6</sup> mm <sup>4</sup>	10 <sup>3</sup> mm <sup>3</sup>	10 <sup>6</sup> mm <sup>4</sup>	10 <sup>3</sup> mm <sup>3</sup>		
◆ 300 x 90 x 8.0 CC	28.5	8.0	16.0	284	33.5	9.25	0.915	1.00	0.950	400	3450	44.2	294	2.44	35.0	2.44	35.0	
6.0 CC	21.6	6.0	14.0	288	45.3	12.7	0.712	0.801	0.763	450	2100	32.0	206	1.46	22.4	1.89	26.8	
◆ 250 x 90 x 6.0 CC	19.2	6.0	14.0	238	37.0	12.7	0.825	0.801	0.831	450	2040	20.5	158	1.41	22.2	1.79	26.2	
230 x 75 x 6.0 CC	16.9	6.0	14.0	218	33.7	10.2	0.879	0.925	0.906	450	1950	15.4	132	1.05	18.2	1.05	18.2	
200 x 75 x 6.0 CC	15.5	6.0	14.0	188	28.7	10.2	0.968	0.925	0.955	450	1880	11.0	108	1.00	17.9	1.00	17.9	
◆ 5.0 CC	12.4	4.7	8.7	191	38.9	14.1	0.797	0.741	0.787	450	1240	8.37	79.5	0.560	11.0	0.812	14.3	
180 x 75 x 5.0 CC	11.6	4.7	8.7	171	34.6	14.1	0.863	0.741	0.820	450	1220	6.50	68.4	0.550	11.0	0.787	14.1	
150 x 75 x 5.0 CC	10.5	4.7	8.7	141	28.2	14.1	0.977	0.741	0.869	450	1160	4.22	52.9	0.532	10.9	0.743	13.7	
125 x 65 x 4.0 CC	7.23	3.8	7.8	117	28.8	15.1	0.966	0.705	0.845	450	779	2.00	29.8	0.256	6.24	0.388	8.32	
100 x 50 x 4.0 CC	5.59	3.8	7.8	92.4	22.2	11.1	1.00	0.875	0.944	450	672	1.04	20.1	0.164	4.67	0.174	4.86	
75 x 40 x 4.0 CC	4.25	3.8	7.8	67.4	15.6	8.47	1.00	1.00	1.00	450	541	0.457	12.2	0.0840	3.01	0.0840	3.01	

◆ These items are not commonly stocked but are available on indent. A minimum order quantity may apply on some sizes.

CC = Cold-formed channel.

### Notes:

- Steel grade C450L0/C400L0 (for t ≤ 6.0mm f<sub>y</sub> = 450 MPa and f<sub>U</sub> = 500 MPa, and for t > 6.0mm f<sub>y</sub> = 400 MPa and f<sub>U</sub> = 450 MPa).
- d<sub>e</sub> and b<sub>e</sub> are the effective widths of the web and flange respectively.
- d<sub>e</sub>, b<sub>e</sub> and A<sub>e</sub> are calculated for sections with uniform axial compressive stress f<sub>y</sub>.
- I<sub>eyL</sub> and Z<sub>eyL</sub> are for compression at point 'L'; I<sub>eyR</sub> and Z<sub>eyR</sub> are for compression at point 'R'.

# DURAGAL CHANNELS

## X- AND Y-AXES SECTION PROPERTIES FOR MEMBER STABILITY AS/NZS 4600

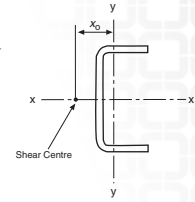

Designation	Mass per metre	Torsion constant	Warping constant	Coordinate of shear centre	Polar radius of gyration about the shear centre	Monosymmetry section constants
$d$ $b_f$ Nominal thickness		$J$	$I_w$	$x_0$	$r_{01}$	$\beta_y$
mm mm mm	kg/m	$10^3\text{mm}^4$	$10^9\text{mm}^6$	mm	mm	mm
◆ 300 x 90 x 8.0 CC	28.5	77.4	37.7	43.4	122	338
◆ 6.0 CC	21.6	33.0	29.6	44.0	123	340
◆ 250 x 90 x 6.0 CC	19.2	29.4	19.2	47.8	110	273
◆ 230 x 75 x 6.0 CC	16.9	25.8	9.48	37.8	96.7	254
◆ 200 x 75 x 6.0 CC	15.5	23.7	6.78	40.2	89.0	217
◆ 5.0 CC	12.4	11.6	5.52	40.6	89.7	218
◆ 180 x 75 x 5.0 CC	11.6	10.9	4.29	42.4	84.9	197
◆ 150 x 75 x 5.0 CC	10.5	9.87	2.77	45.4	78.3	171
◆ 125 x 65 x 4.0 CC	7.23	4.43	1.01	40.0	67.0	145
◆ 100 x 50 x 4.0 CC	5.59	3.43	0.285	30.1	51.8	113
◆ 75 x 40 x 4.0 CC	4.25	2.60	0.0760	24.4	40.1	85.9

◆ These items are not commonly stocked but are available on indent. A minimum order quantity may apply on some sizes.

### Notes:

- Steel grade C450L0/C400L0 (for  $t < 6.0\text{mm}$   $f_y = 450\text{ MPa}$  and  $f_u = 500\text{ MPa}$ , and for  $t > 6.0\text{mm}$   $f_y = 400\text{ MPa}$  and  $f_u = 450\text{ MPa}$ ).
- With the exception of  $J$ , properties are calculated assuming a simplified shape where the bends are eliminated and the section is represented by straight mid-lines in accordance with Clause 2.1.2.1 of AS/NZS 4600.
- $\beta_y$  is zero for channels.

# DURAGAL FLATS

## X- AND Y-AXES AND BASELINE AXIS DIMENSIONS AND FULL SECTION PROPERTIES AS/NZS 4600

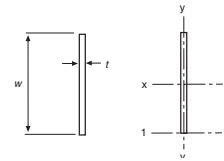

DIMENSIONS			GRADE				SECTION PROPERTIES									
Designation	Mass per metre	Actual thickness	Yield stress	Full area of section	About 1-axis	About x-axis					About y-axis					Torsion constant
						$I_x$	$Z_x$	$S_x$	$r_x$	$I_y$	$Z_y$	$S_y$	$r_y$	$J$		
Width $w$	Nominal thickness	$t$	$f_y$	$A_f$	$I_1$	$10^6\text{mm}^4$	$10^6\text{mm}^4$	$10^3\text{mm}^3$	$10^3\text{mm}^3$	mm	$10^6\text{mm}^4$	$10^3\text{mm}^3$	$10^3\text{mm}^3$	mm	$10^3\text{mm}^4$	
mm	mm	mm	MPa	mm <sup>2</sup>	$10^6\text{mm}^4$	$10^6\text{mm}^4$	$10^3\text{mm}^3$	$10^3\text{mm}^3$	mm	$10^6\text{mm}^4$	$10^3\text{mm}^3$	$10^3\text{mm}^3$	mm	$10^3\text{mm}^4$		
◆ 300 x 8.0 CF	18.8	8.0	350	2400	72.0	18.0	120	180	86.6	0.0128	3.20	4.80	2.31	51.2		
◆ 5.0 CF	11.1	4.7	400	1410	42.3	10.6	70.5	106	86.6	0.00260	1.10	1.66	1.36	10.4		
◆ 250 x 8.0 CF	15.7	8.0	350	2000	41.7	10.4	83.3	125	72.2	0.0107	2.67	4.00	2.31	42.7		
◆ 5.0 CF	9.22	4.7	400	1180	24.5	6.12	49.0	73.4	72.2	0.00216	0.920	1.38	1.36	8.65		
◆ 200 x 8.0 CF	12.6	8.0	350	1600	21.3	5.33	53.3	80.0	57.7	0.00853	2.13	3.20	2.31	34.1		
◆ 6.0 CF	9.42	6.0	400	1200	16.0	4.00	40.0	60.0	57.7	0.00360	1.20	1.80	1.73	14.4		
◆ 5.0 CF	7.38	4.7	400	940	12.5	3.13	31.3	47.0	57.7	0.00173	0.736	1.10	1.36	6.92		
◆ 150 x 8.0 CF	9.42	8.0	350	1200	9.00	2.25	30.0	45.0	43.3	0.00640	1.60	2.40	2.31	25.6		
◆ 6.0 CF	7.07	6.0	400	900	6.75	1.69	22.5	33.8	43.3	0.00270	0.900	1.35	1.73	10.8		
◆ 5.0 CF	5.53	4.7	400	705	5.29	1.32	17.6	26.4	43.3	0.00130	0.552	0.828	1.36	5.19		
◆ 130 x 5.0 CF	4.80	4.7	400	611	3.44	0.860	13.2	19.9	37.5	0.00112	0.479	0.718	1.36	4.50		
◆ 100 x 8.0 CF	6.28	8.0	350	800	2.67	0.667	13.3	20.0	28.9	0.00427	1.07	1.60	2.31	17.1		
◆ 6.0 CF	4.71	6.0	400	600	2.00	0.500	10.0	15.0	28.9	0.00180	0.600	0.900	1.73	7.20		
◆ 5.0 CF	3.69	4.7	400	470	1.57	0.392	7.83	11.8	28.9	0.000865	0.368	0.552	1.36	3.46		
◆ 4.0 CF	2.98	3.8	400	380	1.27	0.317	6.33	9.50	28.9	0.000457	0.241	0.361	1.10	1.83		
◆ 90 x 6.0 CF	4.24	6.0	400	540	1.46	0.365	8.10	12.2	26.0	0.00162	0.540	0.810	1.73	6.48		
◆ 75 x 5.0 CF	2.77	4.7	400	353	0.661	0.165	4.41	6.61	21.7	0.000649	0.276	0.414	1.36	2.60		
◆ 4.0 CF	2.24	3.8	400	285	0.534	0.134	3.56	5.34	21.7	0.000343	0.181	0.271	1.10	1.37		
◆ 65 x 5.0 CF	2.40	4.7	400	306	0.430	0.108	3.31	4.96	18.8	0.000562	0.239	0.359	1.36	2.25		
◆ 4.0 CF	1.94	3.8	400	247	0.348	0.0870	2.68	4.01	18.8	0.000297	0.156	0.235	1.10	1.19		
◆ 55 x 5.0 CF	1.84	4.7	400	235	0.196	0.0490	1.96	2.94	14.4	0.000433	0.184	0.276	1.36	1.73		
◆ 4.0 CF	1.49	3.8	400	190	0.158	0.0396	1.58	2.38	14.4	0.000229	0.120	0.181	1.10	0.915		

◆ These items are not commonly stocked but are available on indent. A minimum order quantity may apply on some sizes.

CF = Cold-formed flats.

### Notes:

- Steel grade C400L0/C350L0 (for  $t < 6.0\text{mm}$   $f_y = 400\text{ MPa}$  and  $f_u = 450\text{ MPa}$ , and for  $t > 6.0\text{mm}$   $f_y = 350\text{ MPa}$  and  $f_u = 400\text{ MPa}$ ).





# BOLTS – HIGH-STRENGTH FRICTION GRIP

AS/NZS 1252:1996

M	16	20	24	30	36
35	●				
40	●	●			
45	●	●			
50	●	●	●		
55	●	●	●		
60	●	●	●		
65	●	●	●		
70	●	●	●		
75	●	●	●	●	
80	●	●	●	●	
90	●	●	●	●	
100	●	●	●	●	●
110	●	●	●	●	●
120	●	●	●	●	●
130	●	●	●	●	●
140	●	●	●	●	●
150	●	●	●	●	●
160	●	●	●	●	
180	●	●	●	●	
200	●	●	●	●	
220	●	●	●		
240	●	●	●		
260		●	●		
280		●	●		
300		●	●		

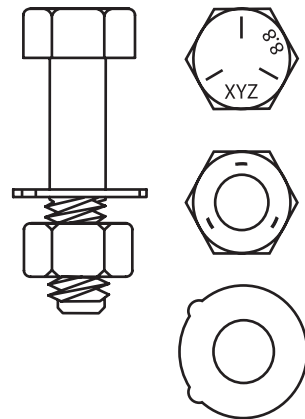

These bolts are used where loads are transmitted through the joined members by nature of the clamping force produced by the bolts. The result is that the bolts are subjected to tensile stresses only, whereas rivets in riveted joints are subjected at the same time to shear and bearing stresses.

## COMPLIANCE WITH AS/NZS 1252:1996

This Standard specifies the dimensional, material and marking requirements for steel bolts of property class 8.8 and steel nuts of property class 8 with ISO metric coarse pitch series threads in diameters from 16mm to 36mm and associated hardened and tempered steel washers intended for use in steel structures.

### AS/NZS 1252:1996 CLAUSE 1.5 – MARKING

**1.5.1 BOLTS** High-strength steel bolts shall be marked with the following information:

- The property class symbol with or without the separating point embossed or indented on top of the head or indented or rolled into one of the hexagon flats.
- Three radial lines approximately 120 degrees apart embossed or indented on top of the head.
- The trade (identification) mark of the manufacturer embossed or indented on top of the head.

**1.5.2 NUTS** High-strength steel nuts shall be marked with the following information:

- The property class symbol indented or rolled into a hexagon flat or the bearing surface, or embossed or indented on the chamfer surface.
- Three circumferential arcs approximately 120 degrees apart embossed or indented on the non-bearing face or for double-chamfered nuts, indented on one or both of the bearing faces.
- The trade (identification) mark of the manufacturer embossed or indented on an external chamfer or indented on the bearing face.

### 1.5.3 WASHERS

Flat round washers for use with high strength steel bolts and nuts for structural engineering shall be identified by the provision of three ribs as shown in figure (c).



(a) Bolt Marking



(b) Nut Marking



(c) Washer Marking

## PURLINS

Steel & Tube is a major manufacturer and supplier of profile metal roofing, cladding and rainwater products. We offer profile shapes in a range of thicknesses, materials and finishes to satisfy every requirement and preference. Our high-strength galvanised cold-formed steel purlins also provide a complete system suitable for supporting a wide range of roofing and cladding materials.

For product datasheets, technical load tables and recommended roofing installers in your area see our website: [www.steelandtube.co.nz](http://www.steelandtube.co.nz).

### SINGLE BRACING

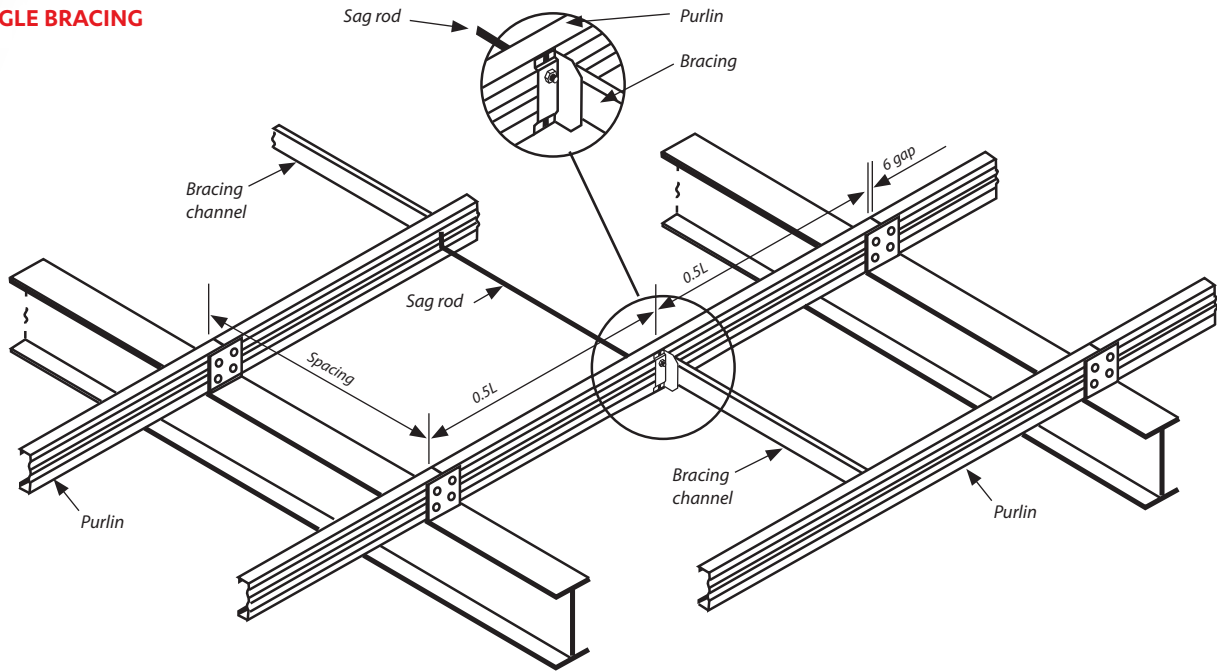

### BRACING LAYOUT

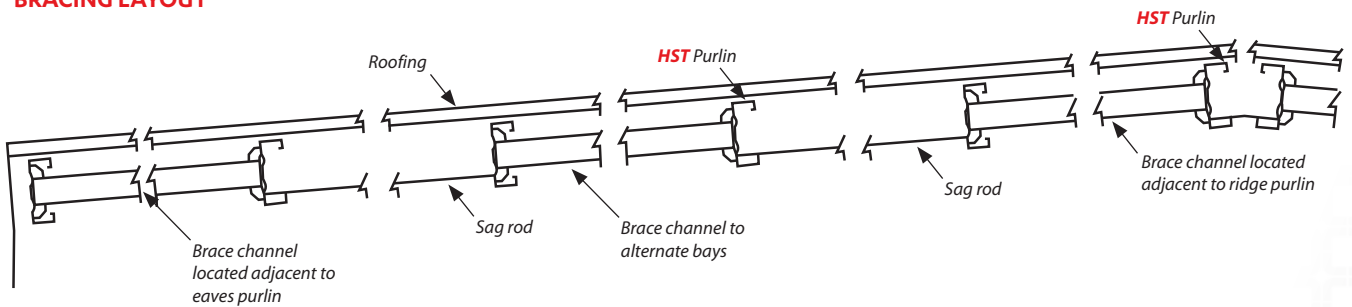

# PURLINS

## SPEED CHANNEL BRACKETS

NB. Brace length equal to purlin spacing less 3 mm

### SPEED CHANNEL BRACING ASSEMBLY ADJUSTABLE CLEAT

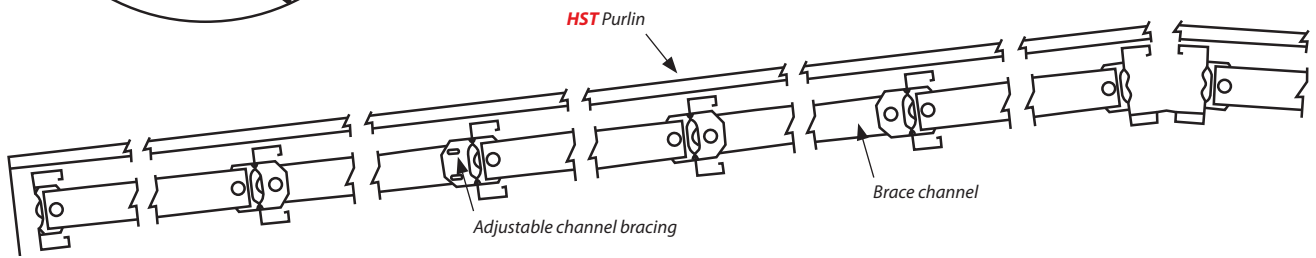
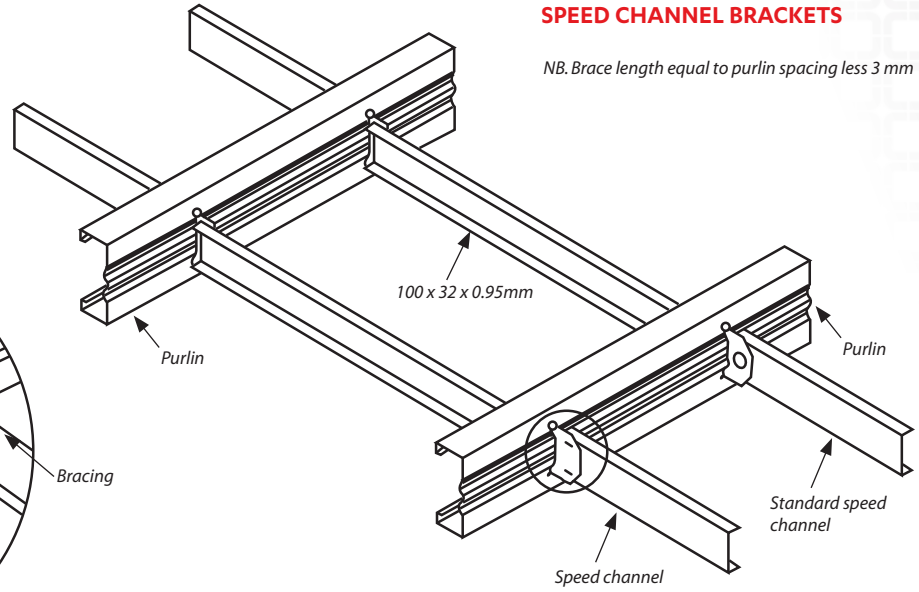
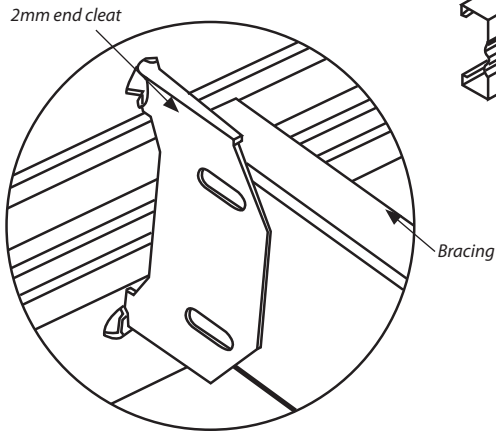

## PURLIN CLEATS

### HST 100

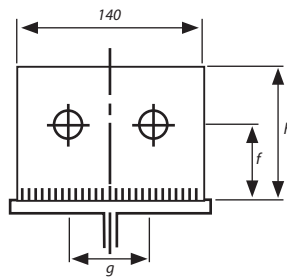
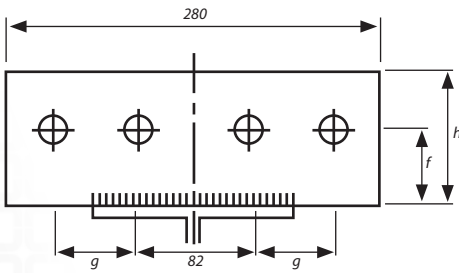

HST 150, HST 200, HST 250, HST 300, HST 350, HST 400

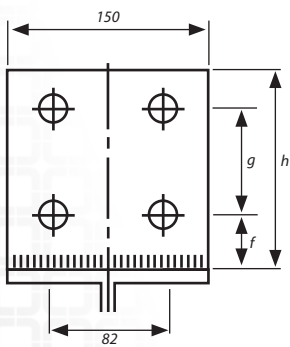

Cleats at internal supports

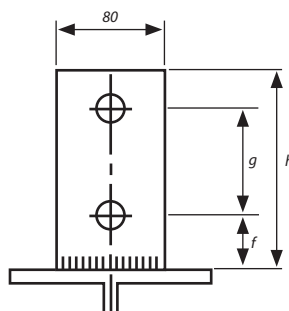

Cleats at end supports

### DIMENSIONS

PURLIN	F	G	H
HST 100	57	64	100
HST 150	41	80	150
HST 200	48	120	200
HST 250	53	160	250
HST 300	55	200	300
HST 350	60	240	340
HST 400	70	280	380

## ROOFING

**ST7** is a medium rib trapezoidal profile of popular configuration.

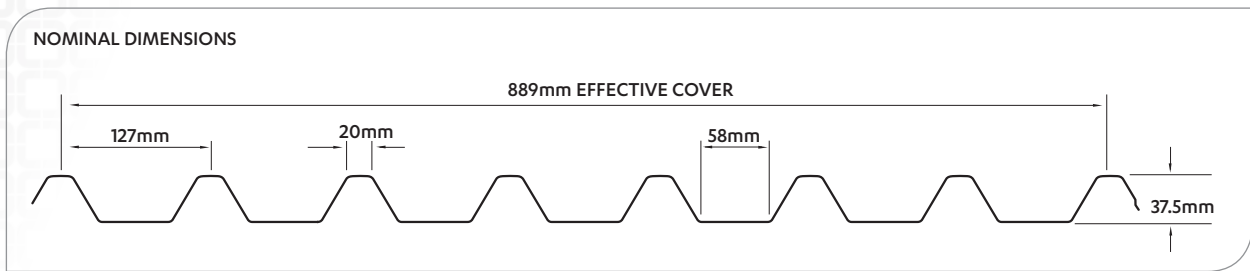

**Custom Orb** is a premium quality corrugated profile manufactured under licence to BHP.

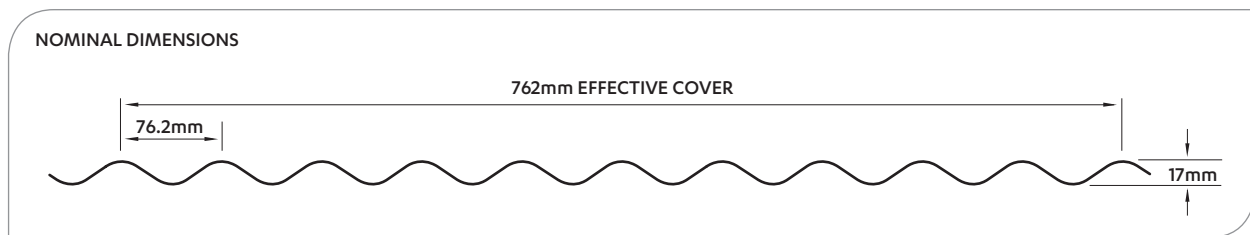

**Plumbdek** is a low rib, five-ribbed trapezoidal product offering economy and exceptional performance.

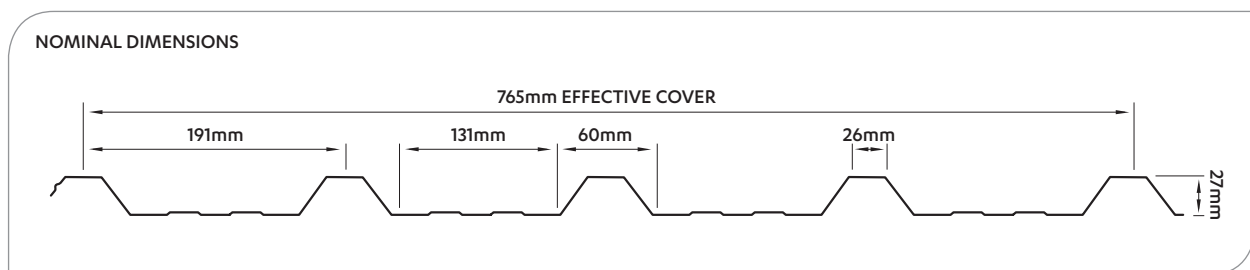

**ST963** is a profiled metal roofing and cladding profile, having four trapezoidal ribs of 46mm in height. Unique design enhancements stiffen the rib shape to provide resistance to both wind uplift and point load distortion.

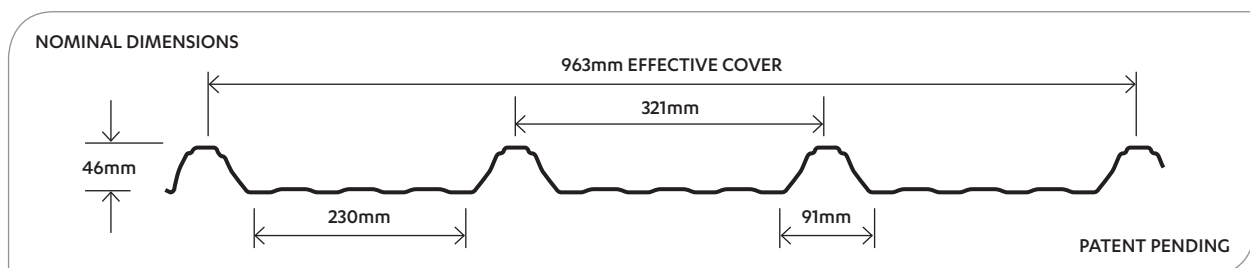

## ROOFING

**ST900** is a medium rib profile. Developed for the commercial and industrial roofing and cladding markets, it is equally suitable in residential settings where a bolder look is desired.

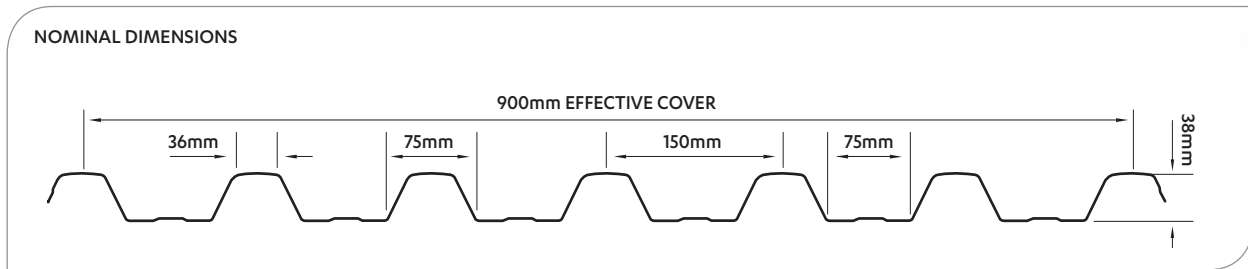

**Multispan** is a high-ribbed trapezoidal product offering exceptional performance and economy.

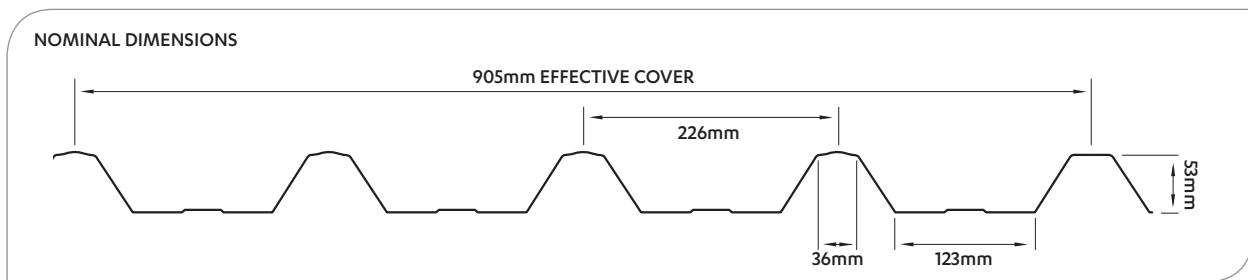

## STANDARDS

The following is a list and brief description of standards for pressure pipe, structural steel, steel plate, merchant bar section and structural fastenings.

**AS/NZS 1163:2009**—covers cold-formed hollows sections (CHS, SHS, RHS). Changes to this standard include higher testing and recording plus improved traceability. For more information on this standard see [www.buildwithstandards.com.au](http://www.buildwithstandards.com.au).

**AS/NZS 3679.1.2010**—covers structural and merchant bar products. The new standard has a section on seismic steel products that covers higher testing and recording plus traceability. For more information on this standard see [www.buildwithstandards.com.au](http://www.buildwithstandards.com.au).

**AS 1074:1989**—applies to general purpose electric welded resistance tube, plain ends, screwed and socketed tube in light, medium and heavy wall. Tube finish can be black, primed and galvanised.

**BS 3059 1987**—this standard is in two parts. Part 1 is for low tensile carbon steel tubes without specified elevated temperature properties. Part 2 covers carbon alloy and austenitic stainless steel tubes with specified elevated temperature properties.

**ASTM A106 SEAMLESS LINEPIPE AND API 5L ERW LINEPIPE**—this standard covers manufacturing heat treatment, marking, chemical testing and tensile requirements. ASTM A106 is the American equivalent of Seamless BS 3602 and is intended primarily for pressure-temperature applications.

API 5L specification for linepipe is a comprehensive standard which covers everything from tensile to pressure testing. This product is intended for pipeline applications, oil, gas and water.

**AS/NZS 1252 1996**—covers high-strength friction grip structural bolts and nuts used in heavy steel construction.

For more information on the above standards contact Steel & Tube on 0800 478 335.

## INDENT SERVICE

The Steel & Tube indent service provides customers with high quality products from recognised international suppliers and mills.

When buying through Steel & Tube supply channels you can be assured that product complies with international standards or AS/NZS standards.

Please contact Steel & Tube for indent price and supply information on 0800 478 335.

PRODUCT GROUP	COMMON SPECIFICATIONS
Steel deformed and plain rounds G300E	AS/NZS4671 G300E
Steel deformed rounds G500E MA (seismic)	AS/NZS4671 G500E MA
Steel Reid bar G500E MA (seismic)	AS/NZS4671 G500E MA
Pre-stressing strand	AS/NZS4672
Mesh seismic G500E MA (ductile)	AS/NZS4671 G500E MA
Steel flats, angles, squares G300	AS/NZS3679 G300
Steel plate G250	AS/NZS1594 HA250 or AS/NZS3678 G250
Steel plate G300	AS/NZS1594 HA300 or AS/NZS3678 G300
Steel plate G350	AS/NZS1594 HA350 or AS/NZS3678 G350
Steel plate pressure (boiler)	AS1548/PT460
Steel plate corrosion	AS/NZS1594 HW350
Steel plate abrasion resistant or high tensile	Quenched and tempered
Steel beams, channels, columns G300SO (seismic)	AS/NZS3679 G300SO
Steel beams, channels, columns G300 (non-seismic)	AS/NZS3679 G300
Steel sheet piling	JIS A 5528 SY295/SY390
RHS/SHS C350LO/C450LO	AS/NZS1163 C350LO/C450LO
RHS/SHS C350LO	AS/NZS1163 C350LO
Linepipe – seamless	ASTM A106 Grade B
Linepipe – ERW pressure	API 5L B
Linepipe – ERW structural C350 or C350LO	AS/NZS1163 C350 or AS/NZS1163 C350LO
Pipe piling	ASTM A252 Grade 2 or ASTM A252 Grade 3
Pipe scaffolding	AS/NZS1163 C250LO
Pipe reticulation	AS1074 or ASTM A135 Grade A
Pipe general purpose	AS1074
Tube boiler	BS3059 Part 1
Steel cold-drawn commercial C1018 or C1020	AISI 1018 or AISI 1020
Steel cold-drawn free cutting C1214 or C1215	AISI 1214 or AISI 1215
Steel cold-drawn medium tensile C1045	AISI 1045
Steel Q&T rounds 4140	AISI 4140
Steel hot-rolled engineering rounds S45C	JIS G4051 S45C
Steel carbon hollow bar	EN10294 Grade 20MnV6

## STEEL & TUBE PUBLICATIONS

Related product catalogues:

- › Steel
- › Purlins & Girts
- › Fastenings
- › Roofing Solutions

You can download these and any of our other publications and technical resources from our website:

[www.steelandtube.co.nz](http://www.steelandtube.co.nz)

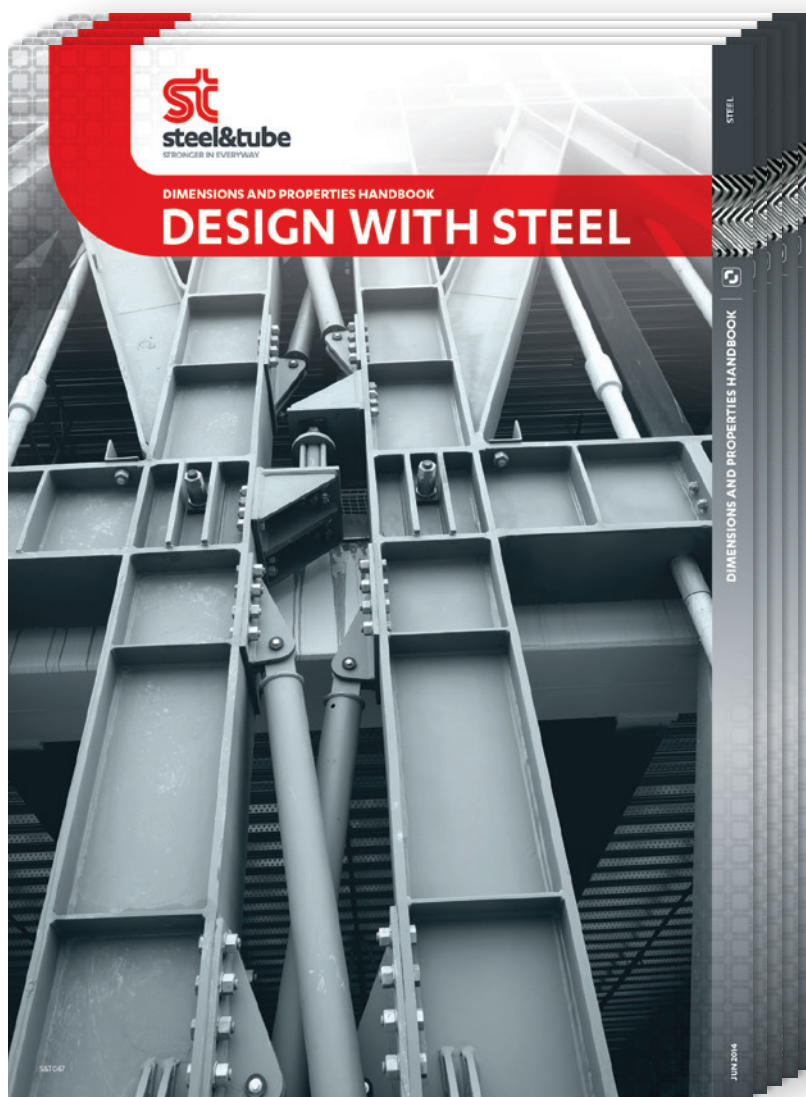



STRONGER IN EVERYWAY

**st steel&tube**

To find out more about our extensive range of products and services:

- › Steel
- › Pipe, Fittings & Valves
- › Stainless Steel
- › Fastenings
- › Chain & Rigging
- › Rural Products
- › Industrial Products
- › Reinforcing
- › Roofing, Cladding, Rainwater Systems & Purlins

**CONTACT US TODAY:**

**0800 478 335**

**[www.steelandtube.co.nz](http://www.steelandtube.co.nz)**