



SMART'CLAD™

The intelligent timber weatherboard

Advanced timber weatherboards with the hidden fixing system.



BRANZ Appraised
683 [2017]
684 [2017]



CODEMARK™
CM70060



PUREPINE
MOULDINGS

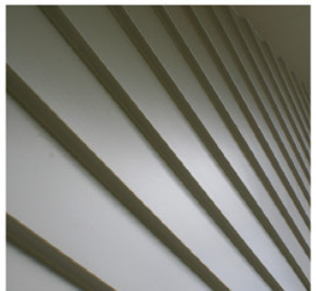
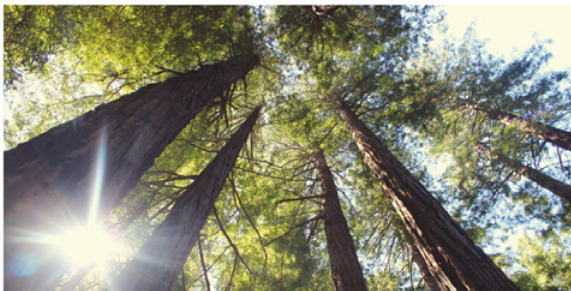

ABOUT US

Purepine Mouldings Limited, manufacturers of SmartClad™ Weatherboards with the hidden fixing system, is part of one of the longest established sawmilling and mouldings manufacturing operations in New Zealand.

Situated just out of Te Puke in the Bay of Plenty, the seven and a half hectare site was established back in 1958 as a moulding factory. In 1968 the sawmill operation was added. Over the years this site has been transformed from the original small factory building to a complex of buildings and yards custom made for the processes carried out on the site.

Certified plantation grown Radiata Pine is now the only species milled. Today the business is a wholly New Zealand owned family business.

SUSTAINABILITY

Sustainability is a vital policy for us.

We source all our logs from sustainable plantation forests found around the Bay of Plenty, Waikato and Poverty Bay and choose with great care to ensure they meet the specifications of the products required from them.

Optimising the timber to reduce wastage is vital. To this end we use highly customised technology based systems to maximise the amount of timber we can use. Being efficient everywhere is important. A good example is the use of waste sawdust and shavings as bio fuel to produce heat for the kiln drying operation.

We believe this type of focus is paramount to sustainable outcome for future generations.

In a world facing dwindling resources, atmospheric pollution and global warming, wood represents our



most renewable raw material, a truly natural product which can be grown and consumed indefinitely.

Collectively the forestry and wood industry is New Zealand's third largest industry contributing an enormous amount to our economy and making up over 12% of New Zealand's export earnings.

As a member of NZ Wood, Purepine Mouldings Limited's business practices are in line with those of this organisation.

CODEMARK

The CodeMark product certification programme is administered in New Zealand by the Ministry of Business, Innovation and Employment. The CodeMark Certificate of Conformity provides a nationally accepted compliance with the NZBC giving confidence and certainty to regulatory authorities and the market.



Products obtaining CodeMark certification shall be accepted by any Building Consent Authority.

Purepine's Smartclad™ Weatherboard system has CodeMark certification. This ensures that all aspects of the manufacture and production of the products are subject to independent third party audits.

CodeMark certification encompasses all aspects from manufacture to installation and to maintain CodeMark certification the Smartclad Weatherboard system must be installed as per the installation instructions contained within this manual.

To comply with the CodeMark programme only Smartclad™ specific components must be used where applicable. Full details of these products and installation information is contained within this document.

BRANZ APPRAISED

Smartclad™ bevelback weatherboard cladding system with the hidden fixing clip system, has been independently assessed by BRANZ and has been appraised as being suitable for New Zealand Building Code compliance.



TABLE OF CONTENTS

About Us	1	Figure 11: Bevelback — Internal 90° Corner — Scribed & Notched.....	23
Sustainability	1	Figure 12: Bevelback — Internal 135° Corner — Scribed & Notched.....	24
NZ Wood	1	Figure 13: Bevelback — Pipe Penetration.....	25
Codemark.....	1	Figure 14: Apron Flashing	26
1. Introduction	3	Figure 15: Bevelback — Inter-Storey Cavity Junction	27
2. Storage and preparation	3	Figure 16: Bevelback — Meter Box Head & Sill.....	28
3. Components supplied by Smartclad	3	Figure 17: Bevelback — Parapet Balustrade Cap Flashing.....	29
4. Components supplied by others	3	Figure 18: Bevelback — Parapet Balustrade Intersection with Wall: Moulding	30
5. Design considerations	4	Figure 19: Bevelback — Parapet Balustrade Intersection with Wall — Scribed & Notched.....	30
6. Installation information	4	Figure 20: Parapet Balustrade Intersection with Wall — diagrams	31
7. Painting Requirements.....	5	Figure 21: Bevelback — Top of Wall — Sloping Soffit	32
8. Nailing Schedule	6	Figure 22: Bevelback — Top of Wall — Flat Soffit.....	33
9. Basic Installation Guide.....	7	Figure 23: Bevelback — Top of Wall — No Soffit	34
9.1 Nail Fixing Method — Cavity and Direct Fix	8	Figure 24: Bevelback — Top of Wall — Reverse Soffit	35
9.2 SmartClad Components.....	9	Figure 25: Bevelback — Window Sill	36
9.3 SmartClad SET-OUT GUIDE.....	10	Figure 26: Bevelback — Window Head.....	37
9.4 Installation and fixing Drawings.....	11-38	Figure 27: Bevelback — Window Jamb.....	38
Figure 1: Bevelback SmartClip Fixing detail	12	Figure 28: Bevelback — Window Head & Sill Facing Board option (Cavity Fix) 39-40	39-40
— Bird's Eye view.....	13	Figure 29: Bevelback — Window Head & Sill Facing Board option (Direct Fix) ..	41-42
Figure 2: Bevelback — Base Of Wall — Concrete Floor.....	14	10. Weatherboard Profiles	43
Figure 3: Bevelback — Base Of Wall — Timber Floor.....	15	11. SmartClad Warranty	44
Figure 4: Bevelback — Enclosed Deck — Concrete Substrate.....	16	12. Disclaimer.....	45
Figure 5: Bevelback — Enclosed Deck — Timber Substrate.....	17	13. Contact Details	46
Figure 6: Weatherboard Joins	18		
Figure 7: Bevelback — External 90° Corner — Boxed	19		
Figure 8: Bevelback — External 90° Corner — Soakers.....	20		
Figure 9: Bevelback — External 135° Corner — Soakers.....	21		
Figure 10: Bevelback — Internal 90° Corner — Moulding.....	22		

1. Introduction

The Smartclad hidden fixing bevelback weatherboard system is designed for use as an external wall cladding on residential and light commercial buildings, where they fall within the scope of NZ3604:2011 Timber Framed Buildings and Acceptable Solutions E2/AS1.

The Smartclad weatherboard system has minimum 15-year life service durability as required by NZS3602:2003, the life service is subject to correct installation, painting and general maintenance. Correctly installed and well maintained weatherboards should deliver a considerably longer service life.

When installed and maintained correctly the Smartclad weatherboard system will meet the NZBC requirements under B1 — Structure, B2 — Durability, E2 — External Moisture and F2 — Hazardous Building Material.

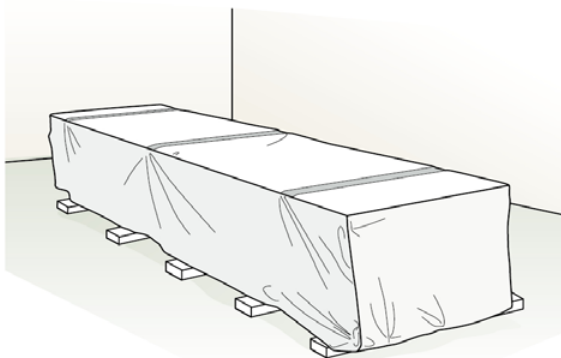

2. Storage and preparation

Ensure that Smartclad Weatherboards are kept dry at all times. Correct storage is essential to avoid exposure to direct sunlight and moisture prior to installation. Smartclad Weatherboards are double primed however this may not prevent moisture uptake if subjected to weather elements.

Storage should be indoors or under a weatherproof cover at all times with at least 150mm ground clearance. Consideration should be given to using a ground cover for extra protection. If moisture content is above 15% or if excessive moisture has caused swelling in the profile, then the product should not be installed until it returns to the original profile and moisture content is below 15%.

3. Components supplied by Smartclad

- 3.1 SmartClad™ Weatherboards are manufactured from finger-jointed Radiata Pine. They are double coated with an alkyd primer.
- 3.2 SmartClip is a patented plastic clip the slots into the pre-formed grooves on the front and rear of the boards and is screwed in place.
- 3.3 Starter Boards are used to provide a level first course of weatherboards. These boards are flat-backed, removing the need to use tilting fillets in most cases.
- 3.4 Pre-scribed Facings, Scribes, Box Corners and Internal Corner Scribes are all pre-scribed timber trims provided to save labour costs involved with scribing each element individually.
- 3.5 Joint and Corner Soakers — joint soakers are used on long walls where weather boards need to be joined. Corner Soakers provide an alternative corner detail to boxed corners.

4. Components supplied by others

- 4.1 Flexible Wall Underlays and Rigid Wall Underlays — complying with NZBC clause E2 table 23. Must be fitted prior to weatherboard or cavity batten installation.
- 4.2 Building Underlay Support — polypropylene strap, 75 mm galvanised mesh, galvanised wire, or additional vertical timber battens for securing the building wrap in place and preventing bulging of the bulk insulation into the drainage cavity. (Note: mesh and wire galvanising must comply with AS/NZS 4534.)
- 4.3 Flexible Sill and Jamb Flashing Tape — complying with NZBC clause E2. Must be fitted prior to weatherboard or cavity batten installation.
- 4.4 Flashings — including external corner flashing, internal corner flashing, horizontal inter-storey joint flashing, sill flashing, window and door head flashing, balustrade and parapet saddle flashing and balustrade and parapet cap flashings. Refer to NZS 3604, Section 4 and NZBC Acceptable Solution E2/AS1, Table 20 for durability requirements.

- 4.5 Cavity Base Closure (Vermin Proofing) — Aluminium, stainless steel or uPVC punched with 3–5 mm diameter holes or slots complying with NZBC Acceptable Solution E2/AS1, Paragraph 9.1.8.3.
- 4.6 Window and Door Trim Cavity Air Seal — air seals complying with NZBC Acceptable Solution E2/AS1 Paragraph 9.1.6.
- 4.7 Aluminium Joinery Head Flashings — as supplied by the joinery manufacturer or building contractor.
- 4.8 Flexible Sealant — sealant complying with NZBC clause E2.

5. Design considerations

- 5.1 Designer Responsibility — The designer must ensure that the details contained in this manual are suitable for the intended building design and that additional detailing is provided for areas outside the scope and specifications of this manual.
- 5.2 Cavity or Direct Fix? — Designers can use the Weathertightness Risk Matrix in NZBC Acceptable Solution E2/AS1 to determine whether the cladding can be direct fixed or whether a drained and vented cavity must be incorporated into the cladding system. This manual gives details for both scenarios.
- 5.3 Ground Clearances — The ground clearances set out in NZS3604:2011 must be adhered to in all cases. The bottom edge of the weatherboards must finish a minimum of 175 above unpaved ground or minimum 100 mm above paved ground. The weatherboards must overlap the bottom plate by at least 50 mm. The bottom edges of the weatherboards must be kept clear of decks or adjacent surfaces/roof flashings at low pitch roof/wall junctions by a minimum of 35 mm. See detail drawings.
- 5.4 Framing — Timber framing must comply with NZS 3604 for buildings or parts of buildings within the scope limitations of NZS 3604. Buildings or parts of buildings outside the scope of NZS 3604 must be to a specific design in accordance with NZS 3603 and AS/NZS 1170. Where specific design is required, the framing must be of at least equivalent stiffness to the framing provisions of

NZS 3604. In all cases studs must be at maximum 600 mm centres. Dwangs must be fitted flush between the studs at maximum 800 mm centres. For timber framed buildings subject to specific design up to a design differential ultimate limit state (ULS) wind pressure of 2.5 kPa, the studs must be at maximum 400 centres.

- 5.5 Cavity Construction — Buildings using cavity construction must incorporate the following additional features:

Cavity vent strip — to prevent vermin entry into the cavity and to add drainage from the cavity

Inter-storey junctions — Walls over two storeys in height must incorporate inter-storey drained joints in accordance with NZBC Acceptable Solution E2/AS1, Paragraph 9.1.9.4(b). See figure 2.18 of this manual.

Structurally Fixed Cavity Battens – Finger-Jointed Radiata pine finished to 45mm wide by minimum 18mm and at least treated to hazard class H3.1.

6. Installation information

(Please see page 6 for Nailing Schedule.)

- 6.1 Prior to Weatherboard Installation The flexible wall underlay (or rigid wall underlay) must be fitted in accordance with manufacturer's instructions. In particular it is essential that the underlay is dressed into the window/door opening, and the flashing tapes fitted to the jambs and sills and at the corners of the opening head.
- 6.2 Cavity Construction
 - 6.2.1 Where cavity construction is specified the cavity battens must be structurally fixed. Please refer to BRANZ Bulletin 582 for further information.
 - 6.2.2 Where studs are at greater than 450 mm centres, a building underlay support (e.g. polypropylene strap) must be installed over the building wrap at maximum 300 mm centres horizontally.
 - 6.2.3 Cavity starter strips — must be fitted to close off the cavity from vermin. The strip should be in accordance with NZBC Acceptable Solution E2/AS1 Paragraph 9.1.8.3.
- 6.3 Flashings — where required, flashings such as corner, sill and saddle flashings must be installed prior to weatherboard installation.

- 6.4 Fitting Weatherboards — See details on pages 12-13.
- 6.5 Joining Weatherboards — Fix weatherboards in full lengths where possible. Where joints are unavoidable, mitre the weatherboard at 45° over a stud/cavity batten and fix with one nail fixing through the overlapping board. Prime the cut ends of all mitre joints with two coats of premium alkyd timber primer before fixing. Alternatively SmartClad™ Joint Soakers may be used.
- 6.6 Fitting Window And Door Joinery — Ideally, weatherboards should be fitted till the top of the opening is reached, then the joinery fitted. This allows for the boards to be fitted beneath the window flange and for the head flashing to be fixed over the window, then subsequent boards fixed over the head flashing.
- 6.7 Prime Cut Ends — prior to fitting weatherboards or other timber trims, prime the cut ends with two coats of premium alkyd timber primer.
- 6.8 Face Nailing — In some situations, it may not be possible to use the SmartClip and screw (e.g. gable ends, top board as the SmartClip may not let the Eaves Moulding sit flat.) Instead the weatherboards can be nailed conventionally, that is use 75 x 3.15 mm hot-dip galvanised or stainless steel ring shank jolt head nails. The nail must be located 40 mm above the bottom edge of the overlap board and be punched a maximum of 2 mm below the surface of the board. Refer to Nail Set out diagrams on page 8. Start fixing the weatherboards at the middle of their length and work outwards to the ends. Pre-drill all nail fixings within 50 mm of the end of the board. Nails should be applied at an upward angle so as to reduce water ingress through the fixing point and under no circumstances shall weatherboard fixings penetrate through flashings as this may jeopardise the weather tightness of the Smartclad system.
- 6.9 External Corners — are finished by either using the SmartClad™ box corners or SmartClad™ corner soakers.
- 6.10 Internal Corners — are finished by either scribing and notching alternate weatherboards or using an Internal Corner Scriber
- 6.11 Facings — After the joinery and weatherboards

are installed, the jambs of the window are finished with either a SmartClad™ Pre-Scribed Scriber or Pre-Scribed Facings.

- 6.12 SmartClad™ Sill — is an optional timber sill board that can be fixed to the sill of windows for aesthetic purposes.
- 6.13 Eaves Moulding — is a cover trim to finish the junction between the top of the wall and the soffit.
- 6.14 Air Seals — A nominal 5 to 10 mm gap must be left between the joinery reveal and the framing. A PEF backing rod is inserted and the gap sealed with a self-expanding polyurethane foam or sealant, in accordance with NZBC Acceptable Solution E2/ AS1 Paragraph 9.1.6.

7. Painting Requirements

Smartclad Weatherboards have two coats of premium factory applied alkyd primer applied when they arrive on site however a top coat with a minimum wet film build of 150 needs to be applied as soon as possible and no later than 45 days from install. Top coats must have a Light Reflective Value (LRV) of 45 or over.

- 7.1 All painting must be carried out to industry standard and in accordance with AS/NZS 2311:2009 (Guide to the painting of buildings). All coating is to be done in accordance with manufacturer's instructions in a well ventilated area. Refer to the coating/primer supplier for all matters relating to health and safety.
- 7.2 Prior to painting weatherboards must be cleaned down, removing any dirt and surface contaminates. All nails holes must be filled and any exposed timber must be immediately primed with a premium alkyd primer.
- 7.3 All exposed faces, including the top edges under the sills and bottom edges of Smartclad Weatherboard must be finished with an exterior paint. Refer to the paint manufacturer for information before starting painting.
- 7.4 It is the responsibility of the specifier to determine normal maintenance requirements to comply with NZBC Acceptable Solution 'B2/AS1'. The extent and nature of maintenance will depend on the geographical location and exposure of the building. As a guide, it is recommended that basic normal maintenance tasks shall include but not be limited to:

- Regular washing down exterior surfaces (at least annually). Refer to paint manufacturers guidelines when cleaning.
- Paint system must be recoated in accordance with the paint manufacturers instructions. (Approximately 7 – 10 years)
- Maintaining the exterior envelope and connections including joints, penetrations, flashings and sealants.
- Cleaning out gutters, blocked pipes and overflows as required,
- Pruning back vegetation close to or touching the building
- The clearances between the bottom edge of Smartclad Starter board and the finished/unfinished ground must always be maintained.

7.5 Light Reflective Values (LRV)

The effect of LRV's on painted timber products is well documented. The LRV of a colour is an indication of what the temperature of the paint surface and substrate should reach in direct sunlight. We also know that as clouds pass over, temperatures on the surface can change rapidly. This rapid change in temperature can cause the paint film and the timber substrate to suffer stresses which can produce dimensional changes and resins in the timber to leach through the paint. This can be reduced by a more reflective colour.



Purepine Mouldings recommend choosing a colour with a LRV of 45 or higher for Smartclad Weatherboards. The product warranty will be void if colours with a LRV less than 45 are used.

8. NAILING SCHEDULE

Profile Nail Size and Treatment* Number & Location Comment

Profile	Nail Size and Treatment*	Number & Location	Comment
Bevelback Weatherboards or Starter Boards	SmartClip and 8 gauge x 65 mm stainless steel screw	1 at each stud	Used in most situations
	75 x 3.15 mm hot-dipped galvanised, jolt head, hand driven or 75 x 3.15 mm stainless steel ring-shanked, jolt head, hand driven	1 at each stud	Only use where SmartClip not suitable such as gable ends and top boards. Located 40mm above bottom edge of the board
Cavity Battens (where required)	60 x 2.8 mm hot-dipped galvanised, or stainless steel ring-shanked, jolt head hand driven or 60 x 2.87 mm hot-dipped galvanised, or 64 x 2.8mm stainless steel ring-shanked, jolt head power driven nail	Maximum 300mm centres	Stagger 12 mm each side of centre line
Box Corner	75 x 3.15 mm hot-dipped galvanised, jolt head, hand driven or 75 x 3.15 mm stainless steel ring-shanked, jolt head, hand driven	Every third board	Bead of sealant required to back of board prior to nailing
Prescribed Facings	75 x 3.15 mm hot-dipped galvanised, jolt head, hand driven or 75 x 3.15 mm stainless steel ring-shanked, jolt head, hand driven	Every third board	Bead of sealant required to back of board prior to nailing
Prescribed Scriber	60 x 2.8 mm hot-dipped galvanised, jolt head, hand driven or 60 x 2.8 mm stainless steel ring-shanked, jolt head, hand driven	Every second board	Bead of sealant required to back of board prior to nailing
Internal Corner Scriber	60 x 2.8 mm hot-dipped galvanised, jolt head, hand driven or 60 x 2.8 mm stainless steel ring-shanked, jolt head, hand driven	Every second board	Bead of sealant required to back of board prior to nailing
SmartClad™ Sill	75 x 3.15 mm hot-dipped galvanised, jolt head, hand driven or 75 x 3.15 mm stainless steel ring-shanked, jolt head, hand driven	Maximum 300mm centres	
Eaves Moulding	60 x 2.8 mm hot-dipped galvanised, jolt head, hand driven or 60 x 2.8 mm stainless steel ring-shanked, jolt head, hand driven	Maximum 300mm centres	

* Treatment depends on corrosion exposure. Hot-dip galvanising must comply with AS/NZS 4680 and stainless steel fixings must be Grade 316.

9. Basic Installation Guide

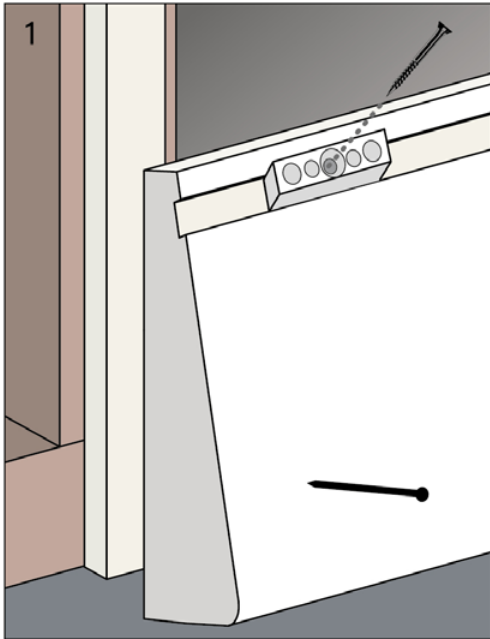

Step 1 Position the starter boards

(When using the SmartClad™ Hidden fixing system.)

- Correct alignment of the starter board is the key to a perfect job. Take time to position this board as accurately as possible.
- Position the starter board so that it overlaps the concrete base of foundation by at least 50mm.
- Confirm that the board is level with a laser or string line.
- Nail the starter board to the bottom plate of the framing 75 to 100mm up from the bottom base board.
- For best results, use a pre-shaped scribe or a self-made story rod as a set out guide to ensure the weatherboards line up with heads of windows.
- Fix top of starter board with SmartClip and 65mm 8-gauge screw.

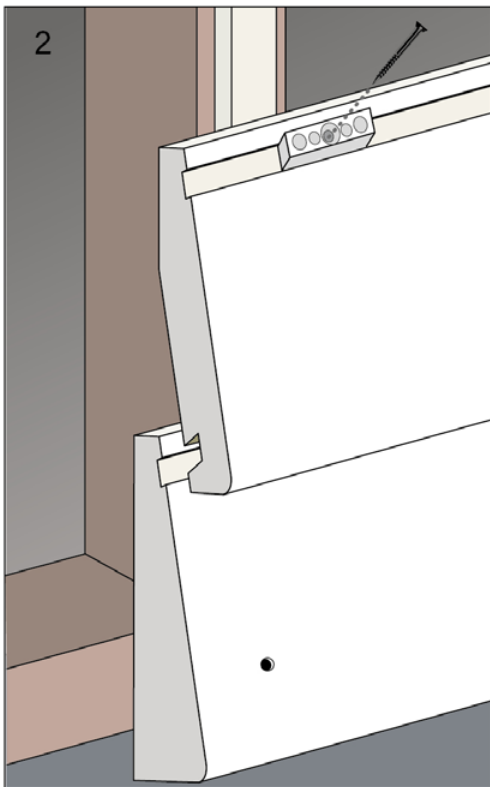

Step 2 Install each weatherboard

- Fit the angled groove on the reverse of the SmartClad™ Weatherboards over the SmartClips along the length of the previous board. The board will sit in place with little effort while you prepare to secure it.
- Fit the SmartClip into the rebate on the top of the weatherboard, making sure the clip is angled upwards.
- With a little downward pressure on top of the board, screw the clip into place using the 65mm x 8-gauge screw, using the angled hole in the clip as a guide.
- If needed, give the weatherboard a gentle downward tap with your hammer to make sure it is seated firmly.
- To ensure you achieve the correct vertical cover of each board, use a pre-shaped scribe as a story rod while you install the weatherboards. This assists the correct fit of the pre-shaped scribes, window facings and box corners once the cladding is installed.



Step 3 Finishing

- Prime cut ends — more paint will help seal the timber from moisture uptake and reduce dimensional movement.
- Paint SmartClad™ Weatherboards as soon as possible to maintain their pristine finish.
- The use of a high quality Acrylic top coat with an LRV of 45 or higher is advised. Ensure a minimum of 150 microns is applied, the more paint applied will aid performance over time.

9.1 Nail Fixing Method – Cavity and Direct Fix

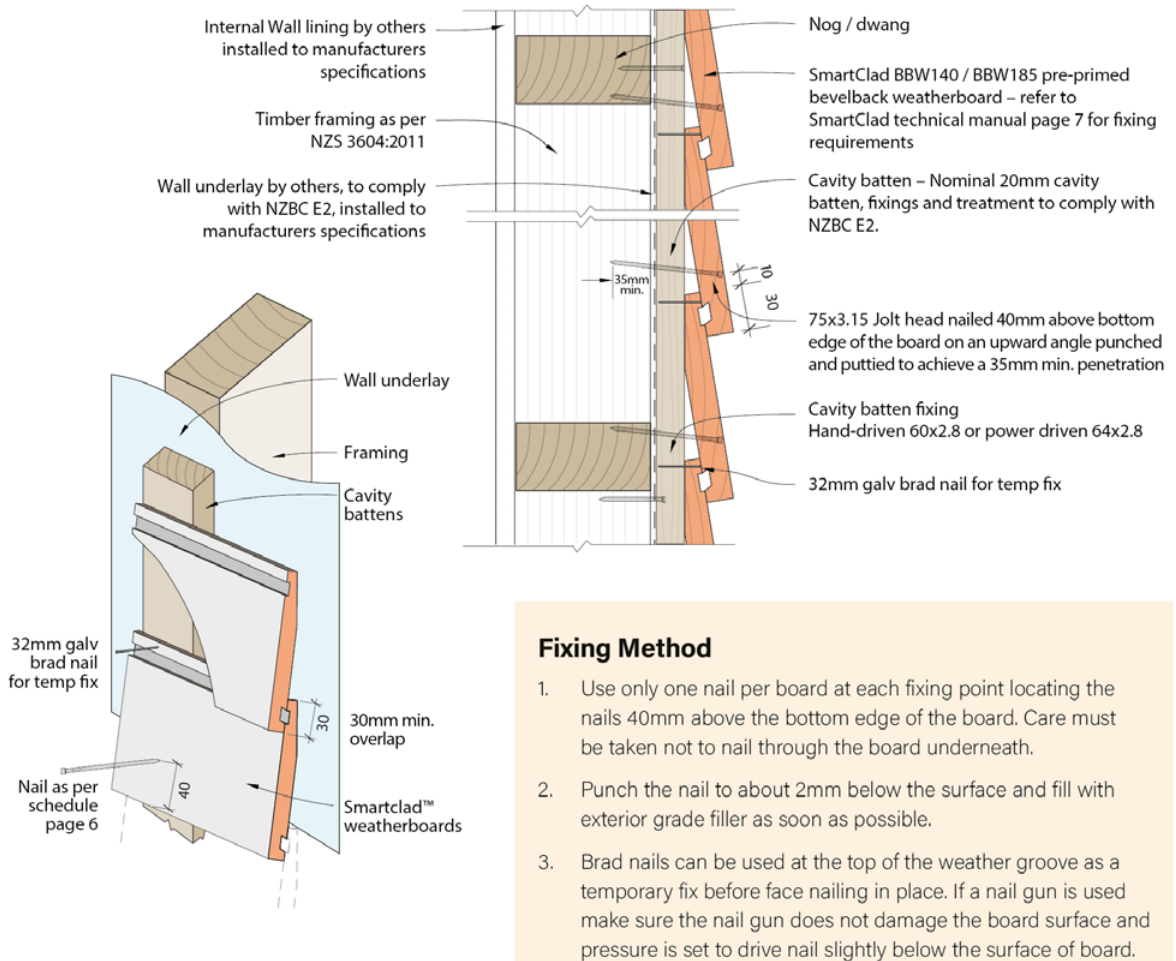

Fixing Method

1. Use only one nail per board at each fixing point locating the nails 40mm above the bottom edge of the board. Care must be taken not to nail through the board underneath.
2. Punch the nail to about 2mm below the surface and fill with exterior grade filler as soon as possible.
3. Brad nails can be used at the top of the weather groove as a temporary fix before face nailing in place. If a nail gun is used make sure the nail gun does not damage the board surface and pressure is set to drive nail slightly below the surface of board.

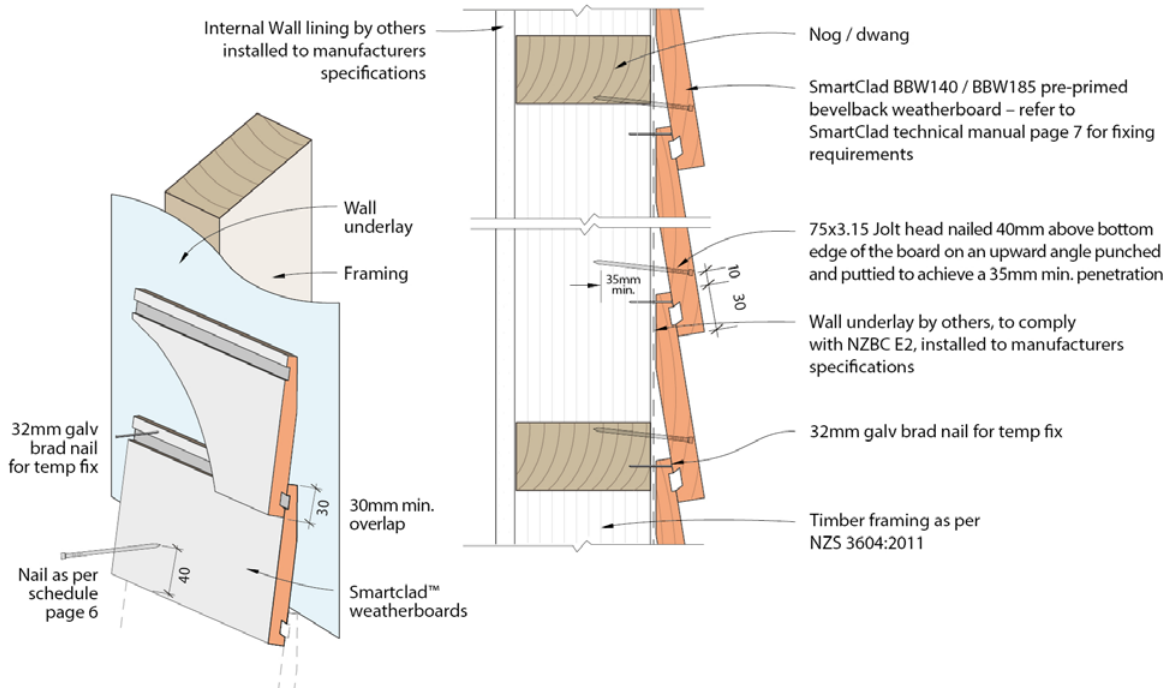

9.2 SmartClad Components

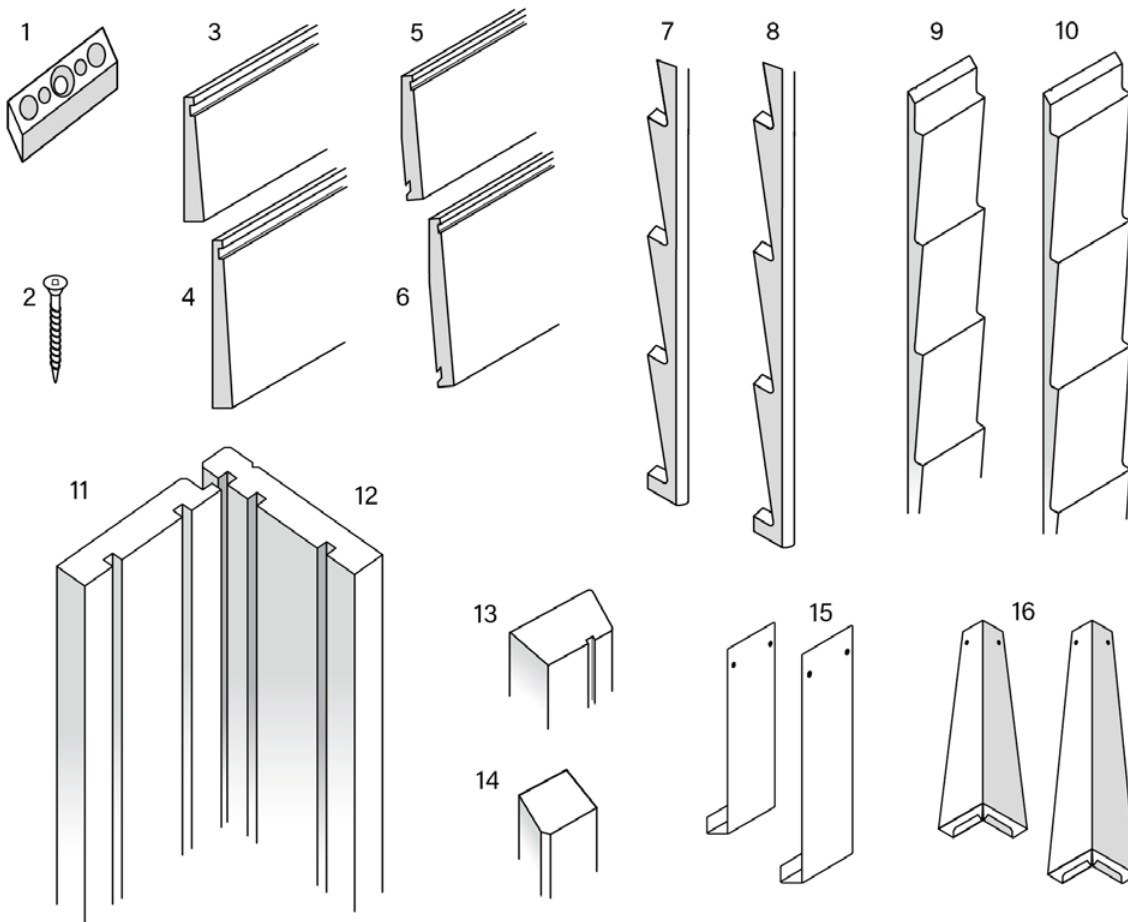

	Product	Code	Size	Length
1	SmartClip 500 per box	SCC	40mm x 18mm	500 per box
2	SmartClad Screws — Stainless	SSS	65mm x 8 Gauge	500 per box
2	SmartClad Screws — Zinc	SSZ	65mm x 8 Gauge	500 per box
3	Starter Board	SB140	140mm x 34mm	6.0 metres
4	Starter Board	SB185	183mm x 32mm	6.0 metres
5	Bevelback Weatherboard	BBW140	140mm x 18mm	6.0 metres
6	Bevelback Weatherboard	BBW185	185mm x 18mm	6.0 metres
7	Pre-shaped Scribe	SPS140	40mm x 18mm	5.4 metres
8	Pre-shaped Scribe	SPS185	40mm x 18mm	5.4 metres
9	Pre-shaped Facing	SPF140	88mm x 34mm	5.4 metres
10	Pre-shaped Facing	SPF185	88mm x 34mm	5.4 metres
11	Two piece Box Corner — Male	SBCM	88mm x 18mm	5.4 metres
12	Two piece Box Corner — Female	SBCF	100mm x 18mm	5.4 metres
13	SmartClad Sill Block	LSB	65mm x 38mm	5.4 metres
14	Internal Corner Board	SISCS	40mm x 40mm	5.4 metres
15	Flat Soaker — Galvanised 140	FSG140	140mm	25 per box
15	Flat Soaker — Stainless 140	FSS140	140mm	25 per box
15	Flat Soaker — Galvanised 185	FSG185	185mm	25 per box
15	Flat Soaker — Stainless 185	FSS185	185mm	25 per box
16	Corner Soaker — Galvanised 140	CSG140	140mm	25 per box
16	Corner Soaker — Galvanised 185	CSG185	185mm	25 per box
16	Corner Soaker — Stainless 140	CSS140	140mm	25 per box
16	Corner Soaker — Stainless 185	CSS185	185mm	25 per box

9.3 SmartClad SET-OUT GUIDE

Direct Fix and Cavity Batten

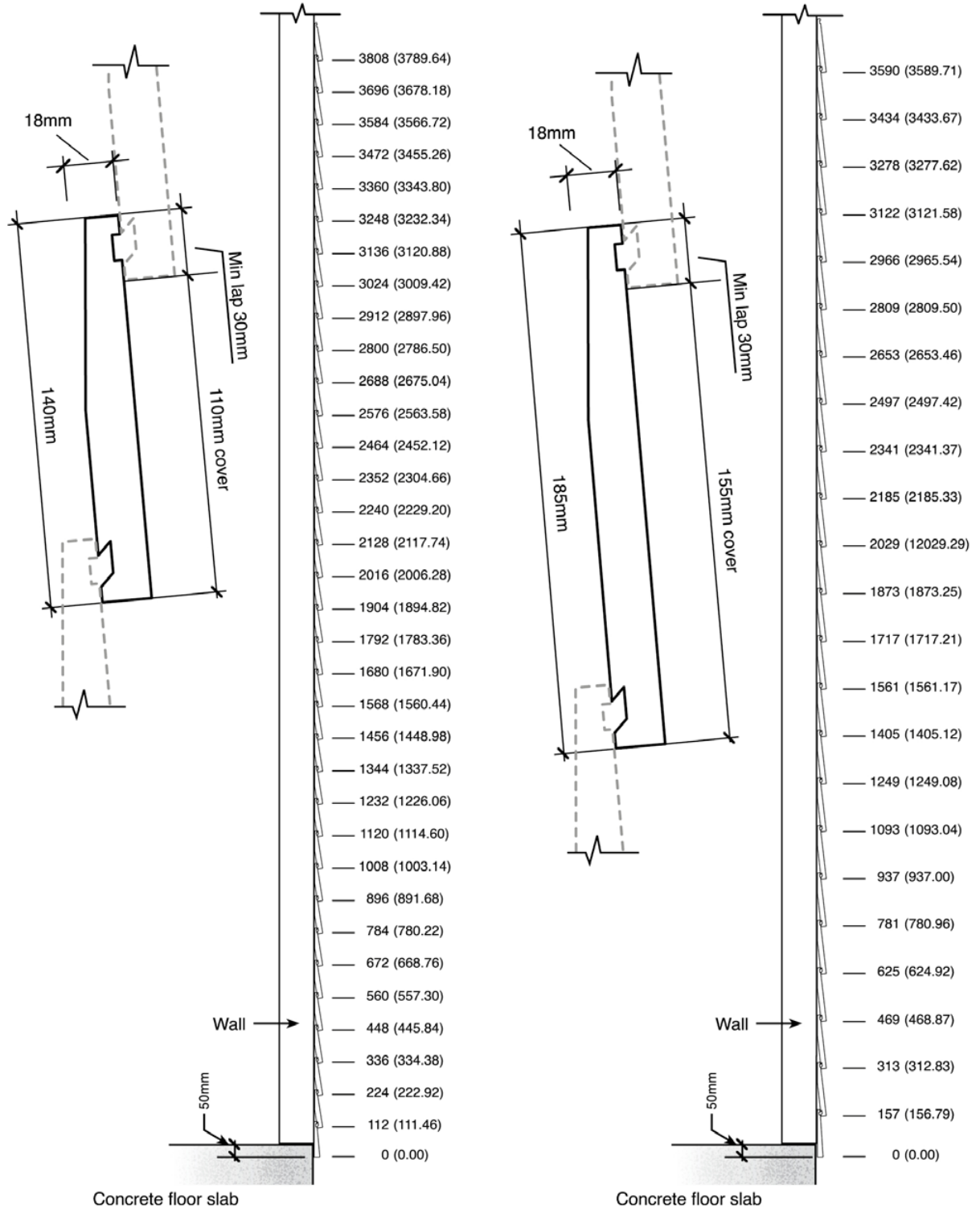



SMART¹CLAD™
The intelligent timber weatherboard

9.4
Installation
Detailing CAD
Drawings



Figure 1: Bevelback SmartClip Fixing detail

PROFILE VIEW

CAVITY FIX

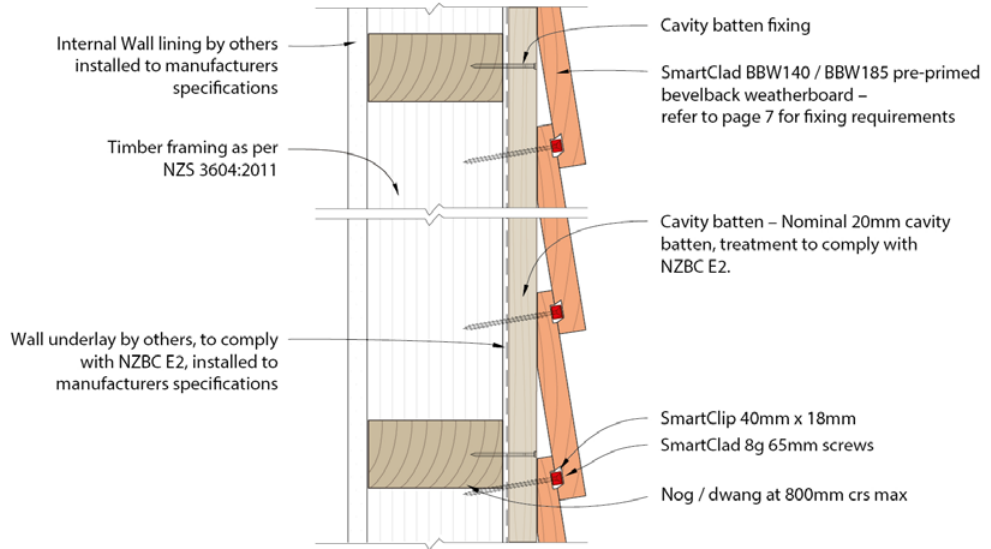

PROFILE VIEW

DIRECT FIX

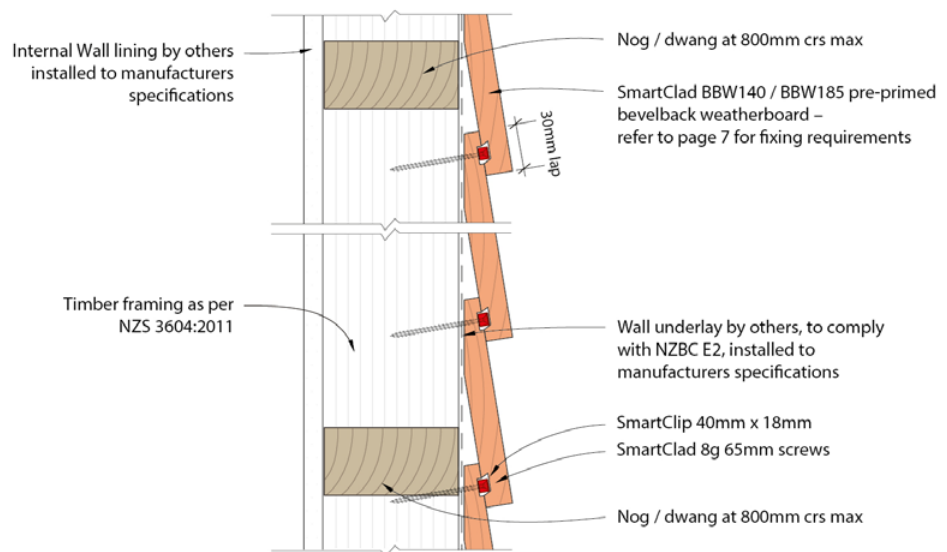
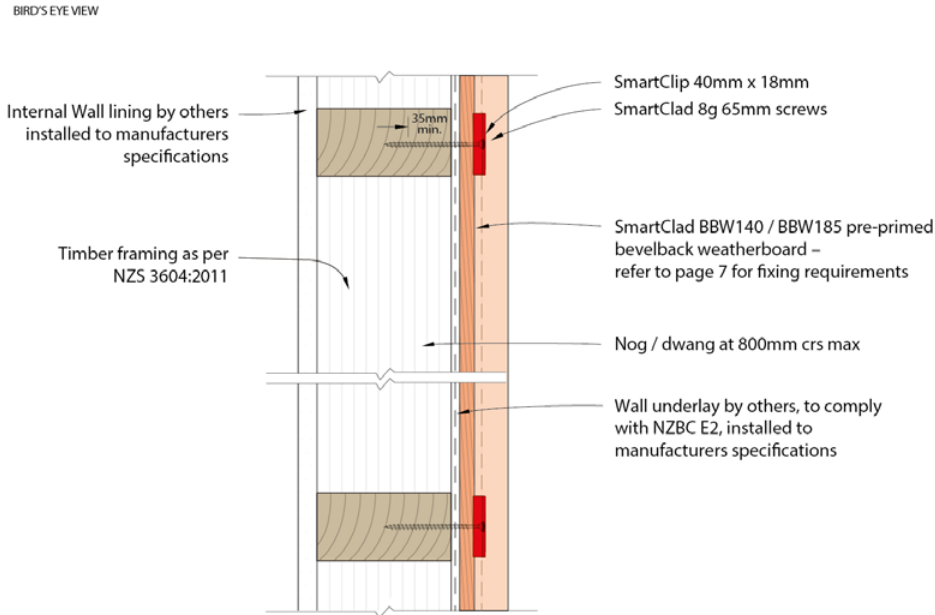
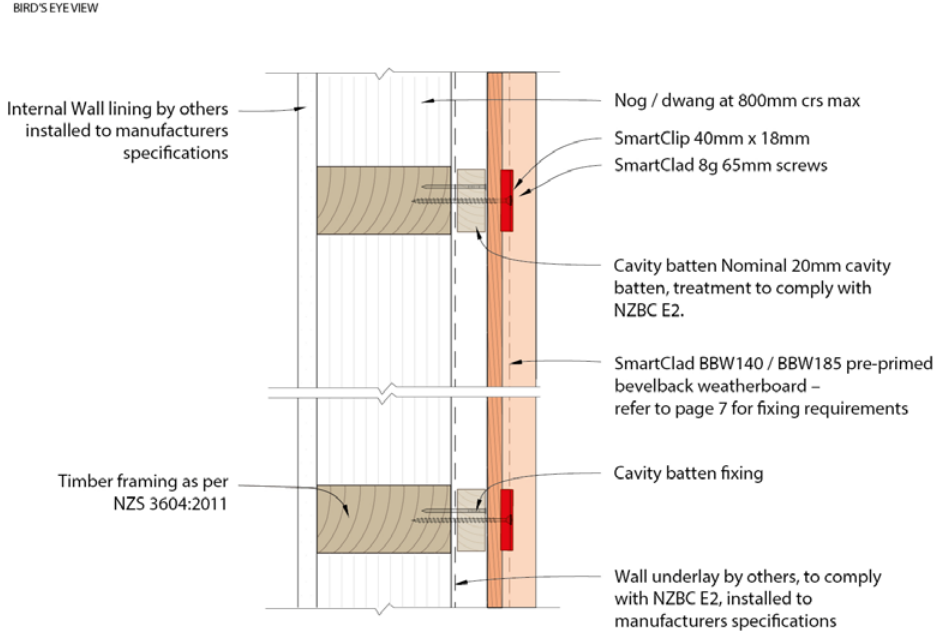

Figure 1a: Bevelback SmartClip Fixing detail



CAVITY FIX

DIRECT FIX

Figure 2: Bevelback — Base Of Wall — Concrete Floor

CAVITY FIX

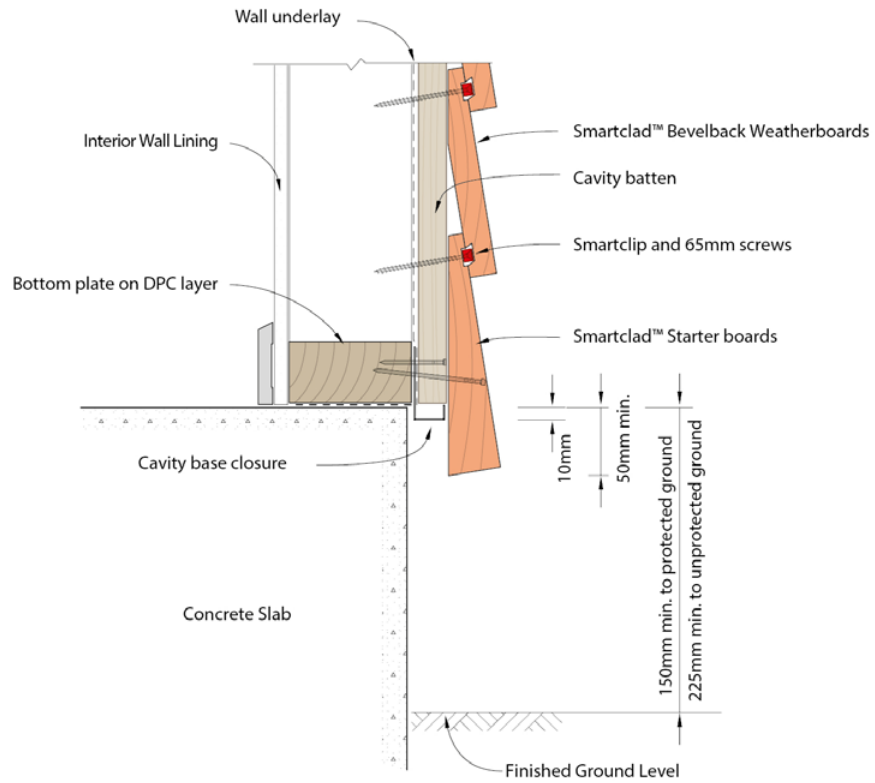

DIRECT FIX

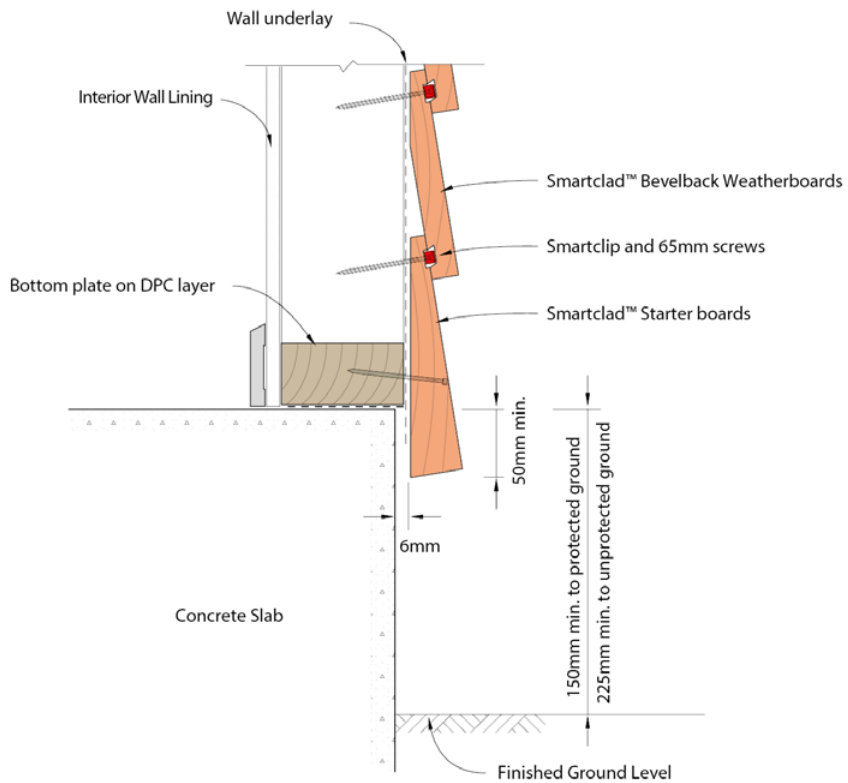
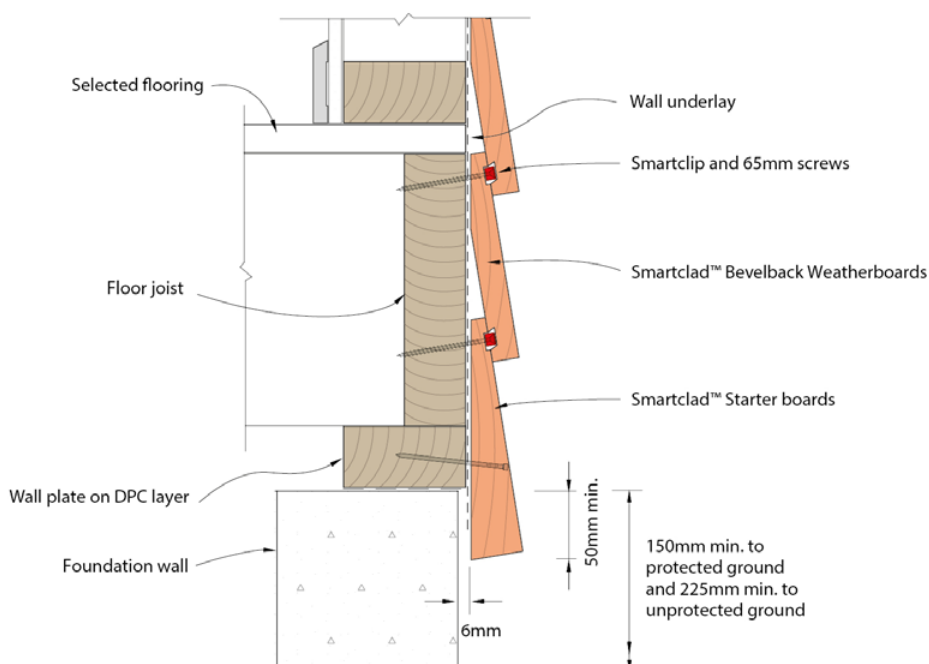
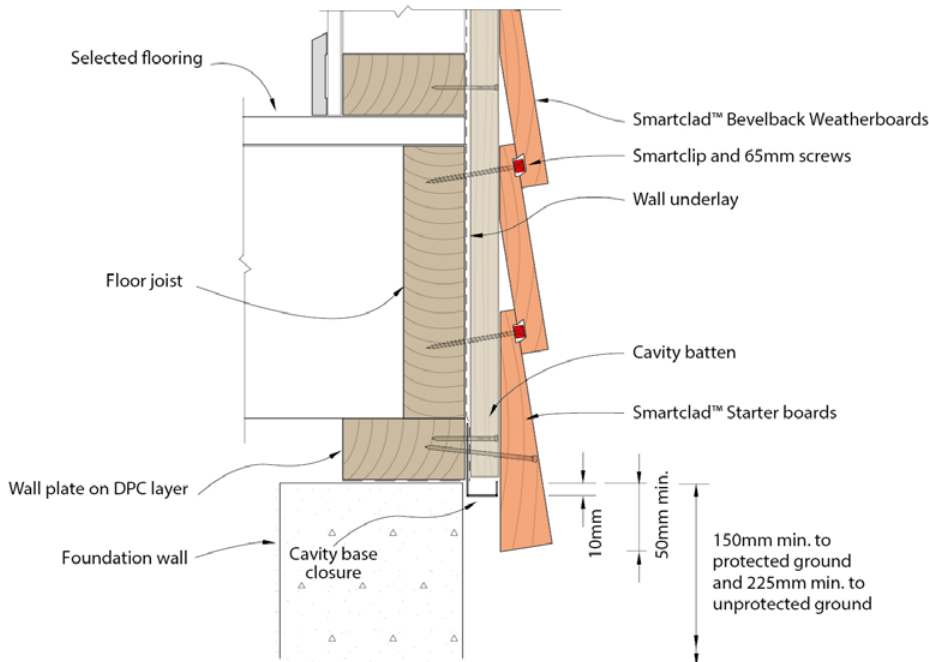

Figure 3: Bevelback — Base Of Wall — Timber Floor



CAVITY FIX

DIRECT FIX

Figure 4: Bevelback — Enclosed Deck — Concrete Substrate

CAVITY FIX

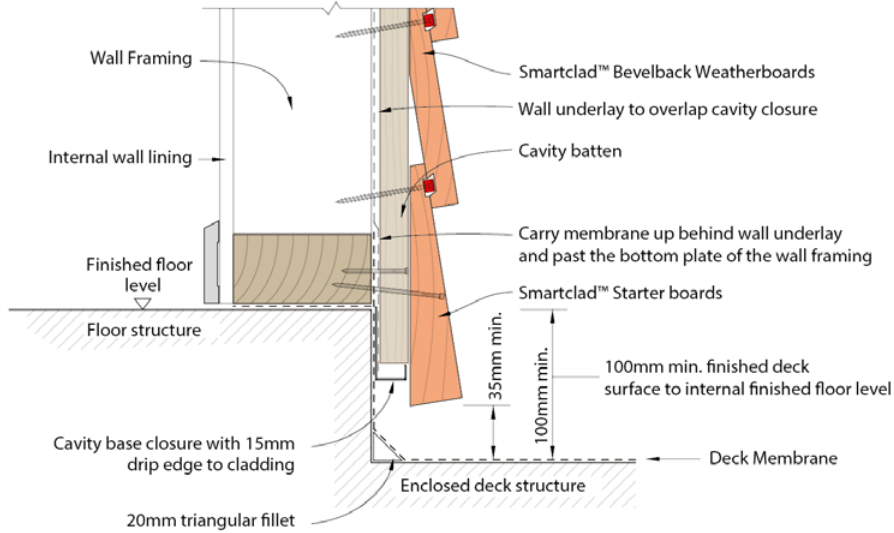

DIRECT FIX

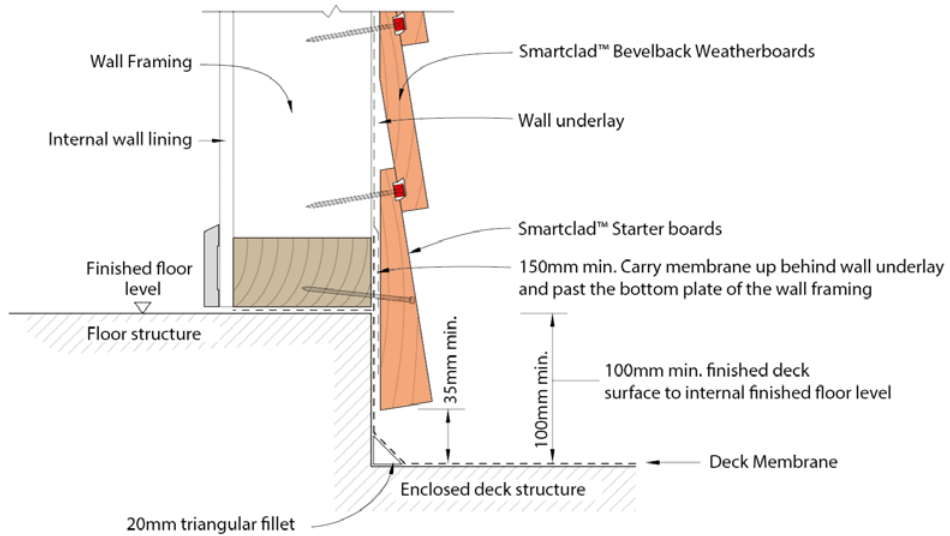
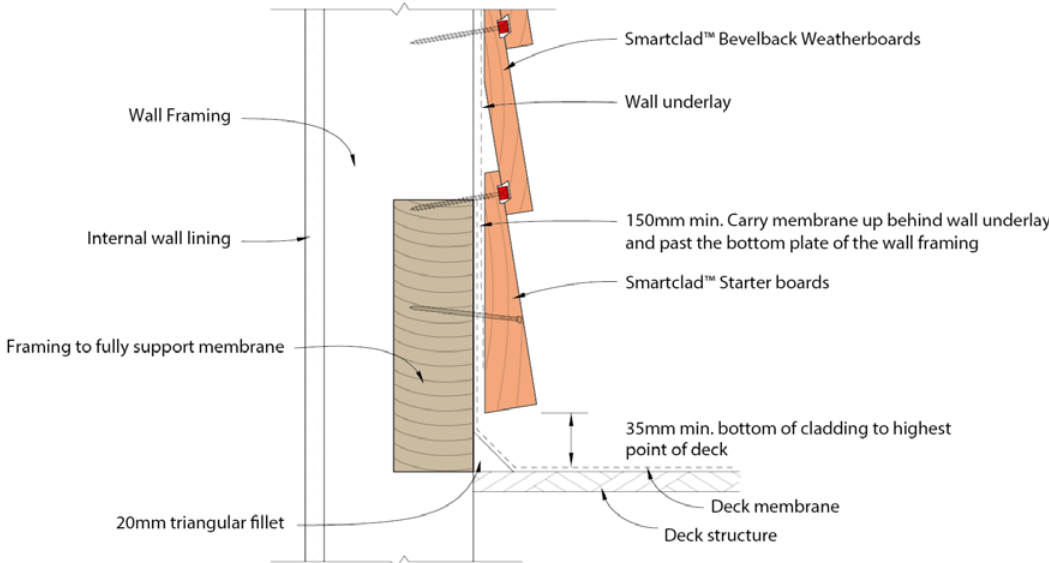
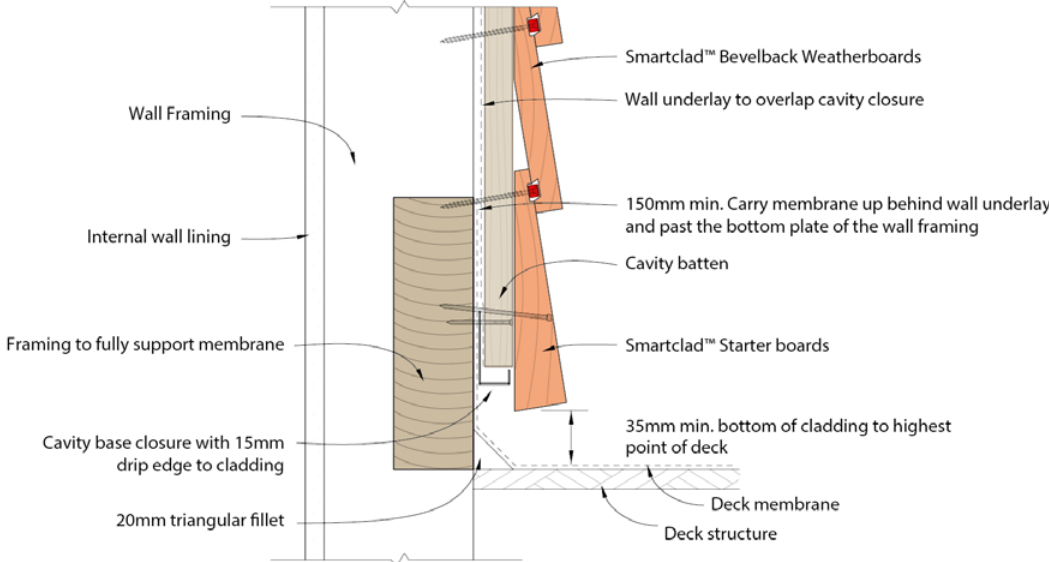

Figure 5: Bevelback — Enclosed Deck — Timber Substrate



CAVITY FIX

DIRECT FIX

Figure 6: Weatherboard Joins

BIRD'S EYE VIEW

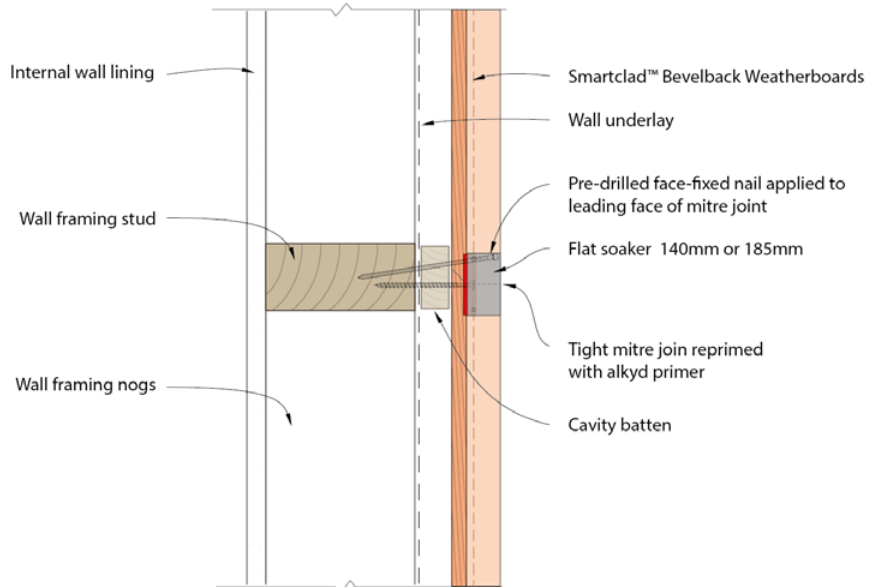

CAVITY FIX

BIRD'S EYE VIEW

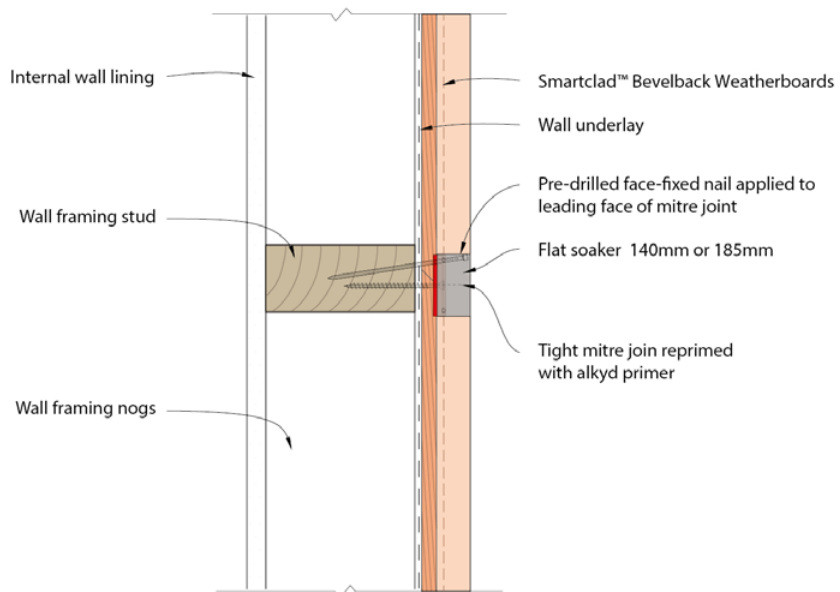

DIRECT FIX

Figure 7: Bevelback — External 90° Corner — Boxed

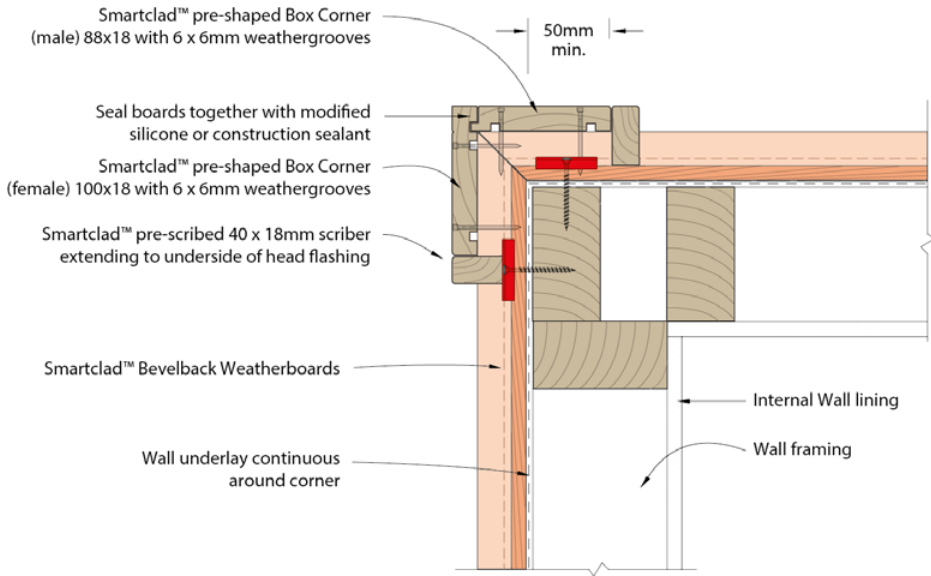
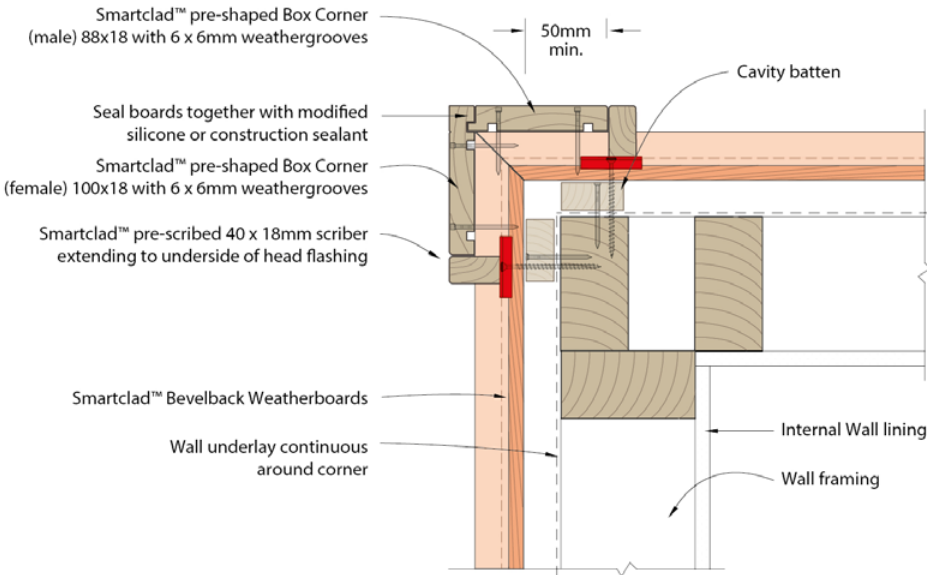
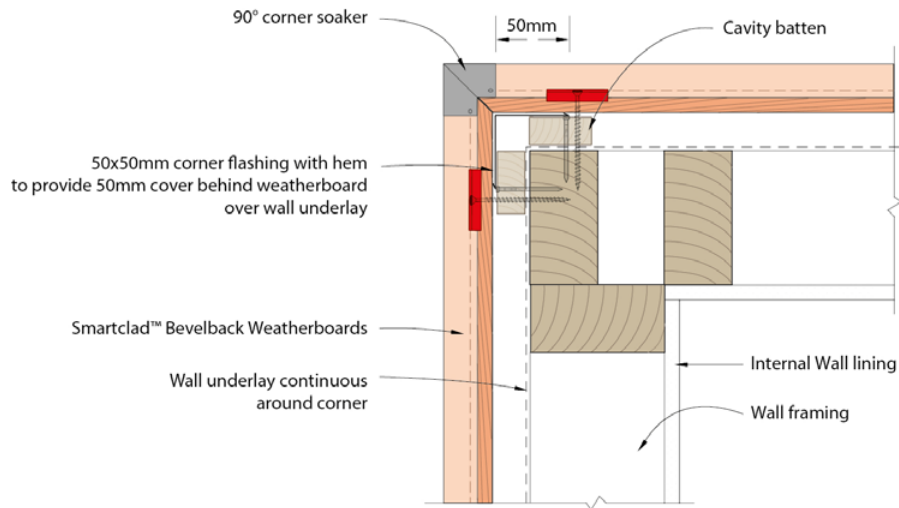

Figure 8: Bevelback — External 90° Corner — Soakers

CAVITY FIX



DIRECT FIX

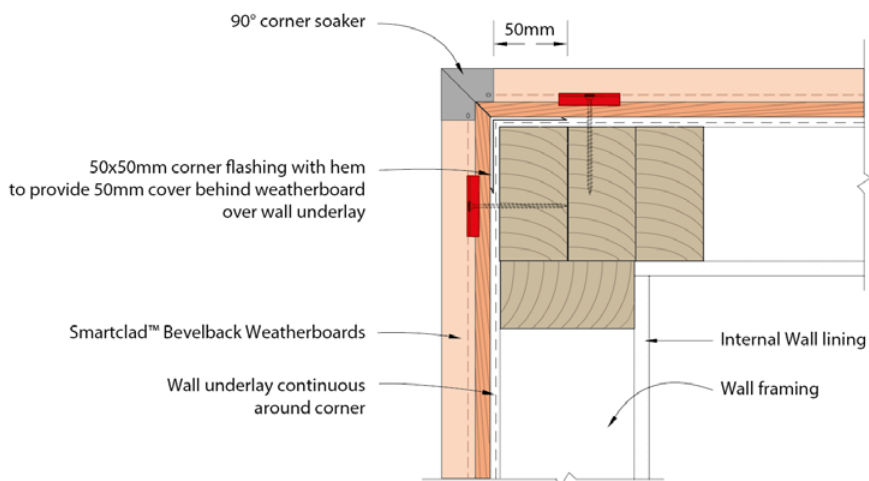
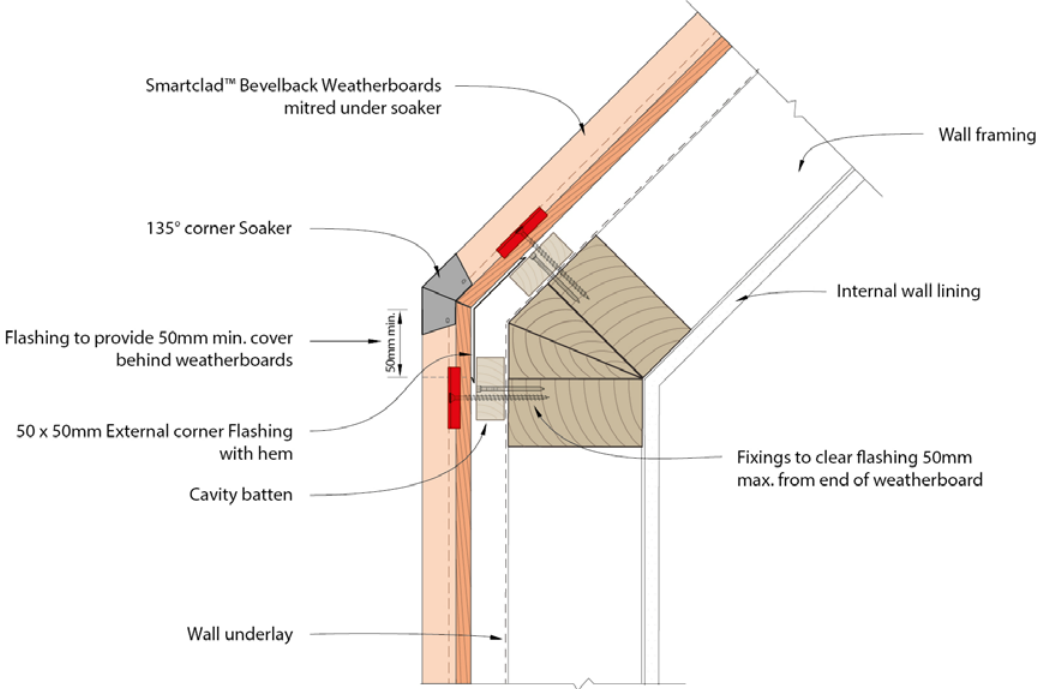
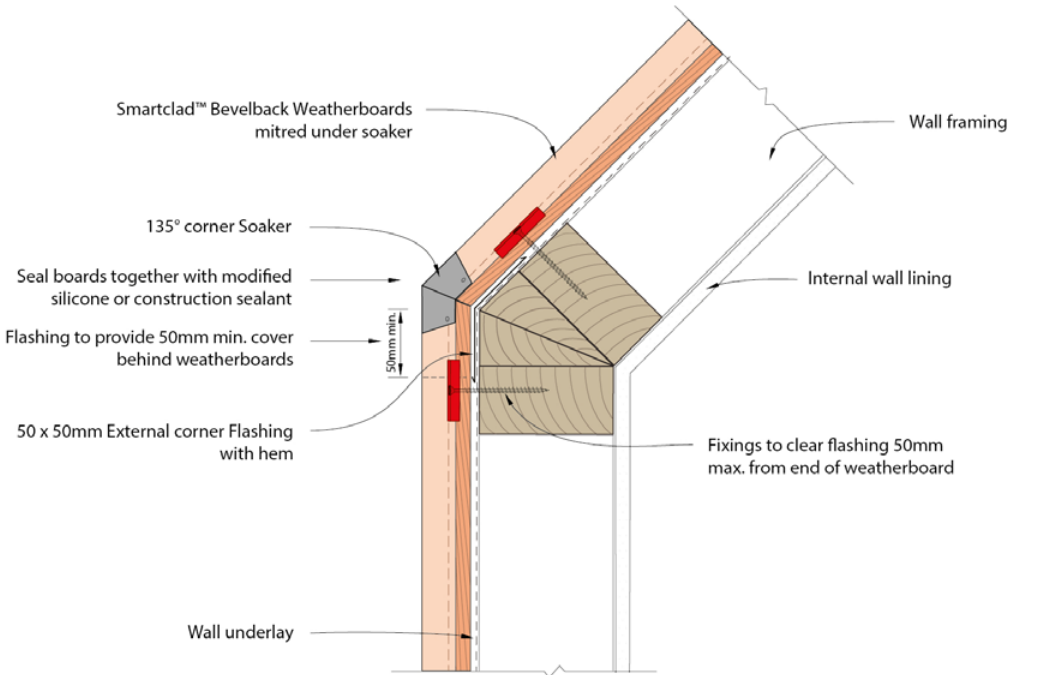

Figure 9: Bevelback — External 135° Corner — Soakers



CAVITY FIX



DIRECT FIX

Figure 10: Bevelback — Internal 90° Corner — Moulding

CAVITY FIX

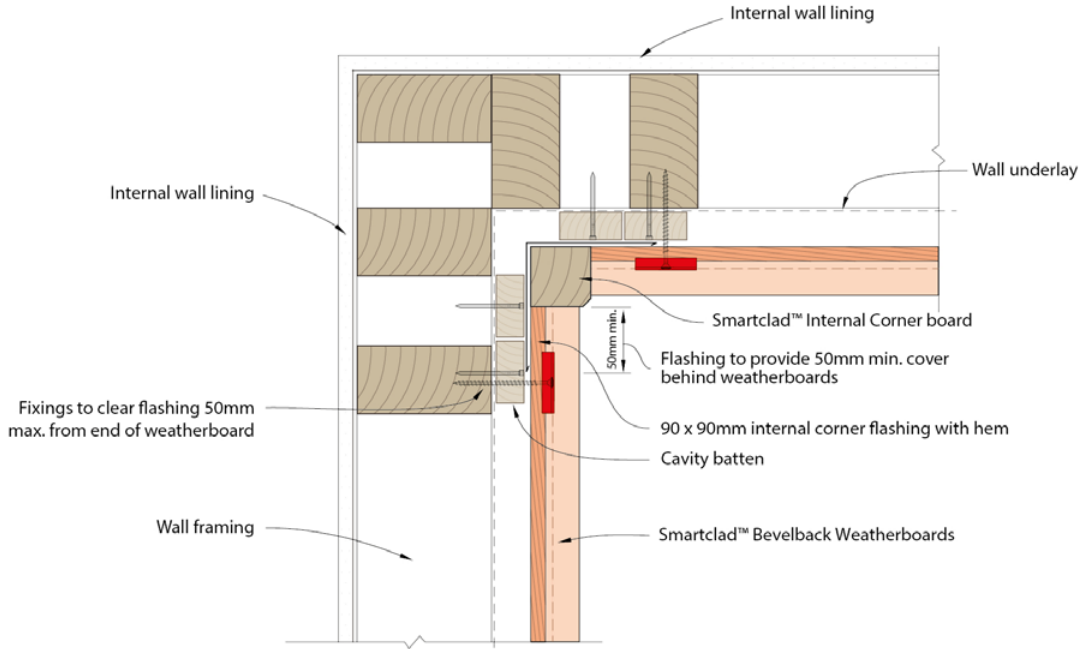

DIRECT FIX

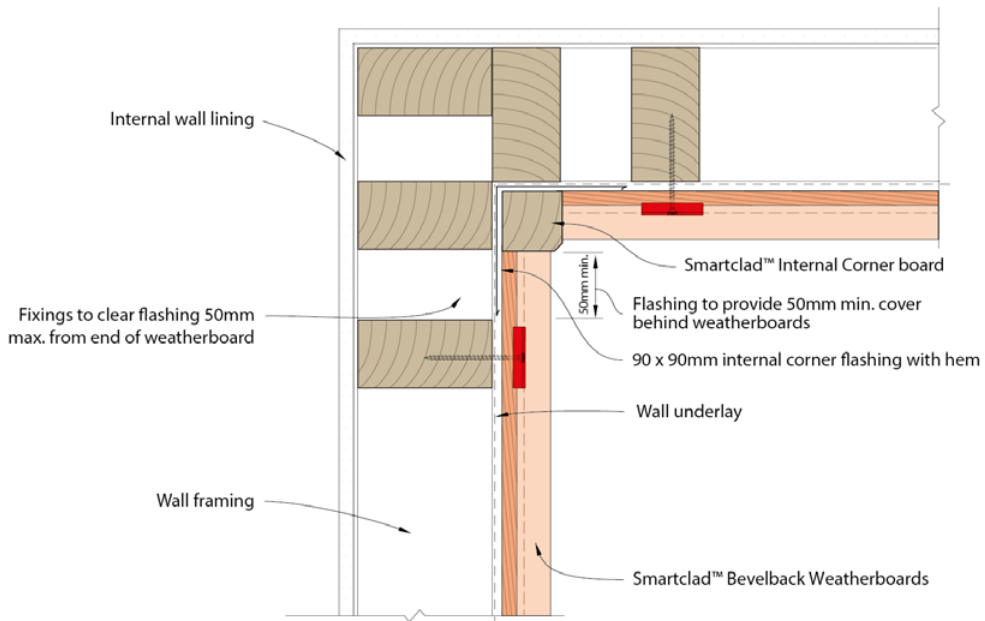
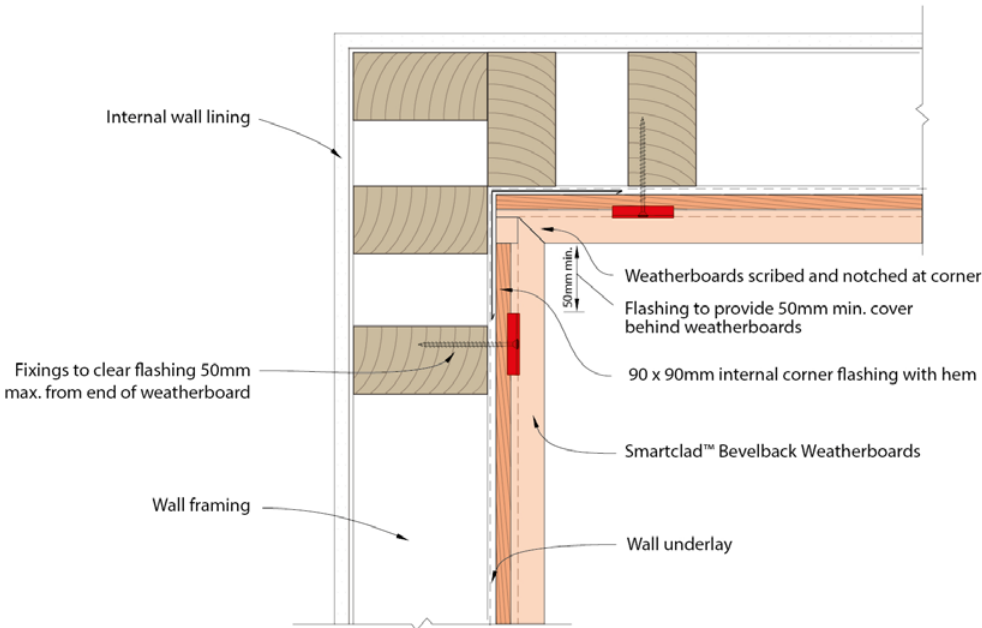
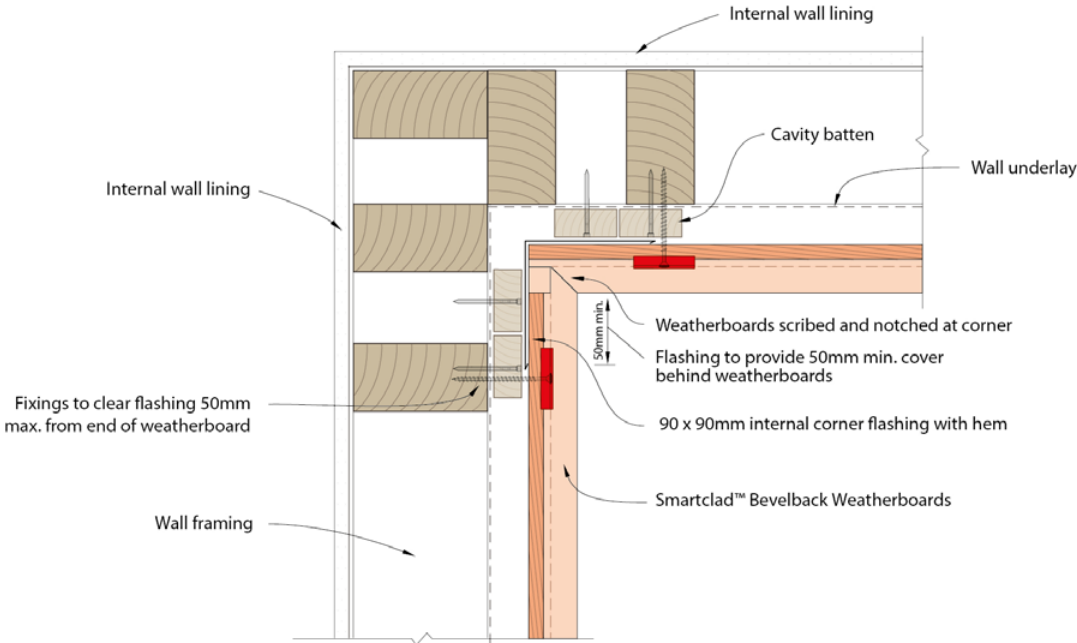

Figure 11: Bevelback — Internal 90° Corner — Scribed & Notched



CAVITY FIX

DIRECT FIX

Figure 12: Bevelback — Internal 135° Corner — Scribed & Notched

CAVITY FIX

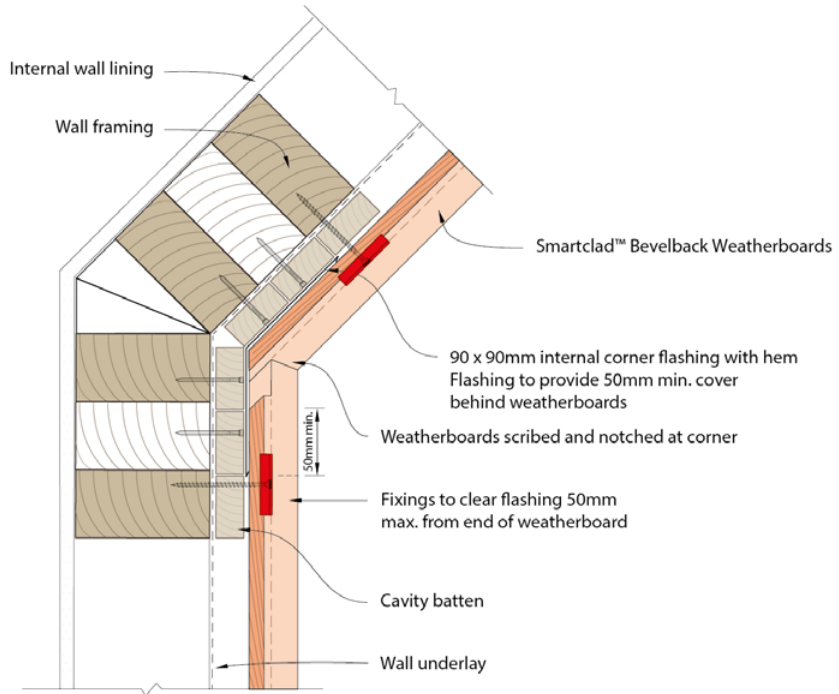

DIRECT FIX

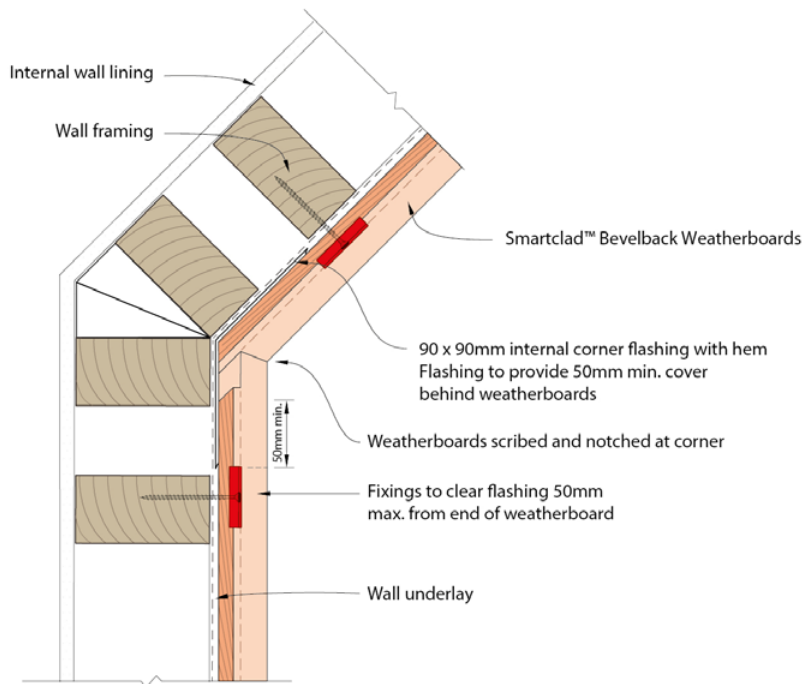
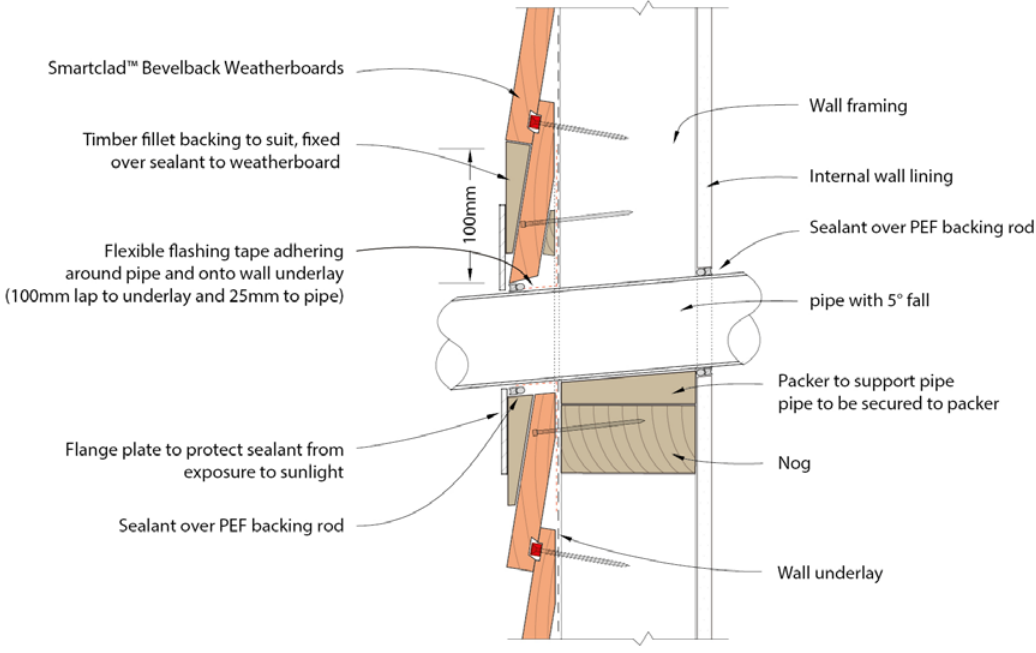
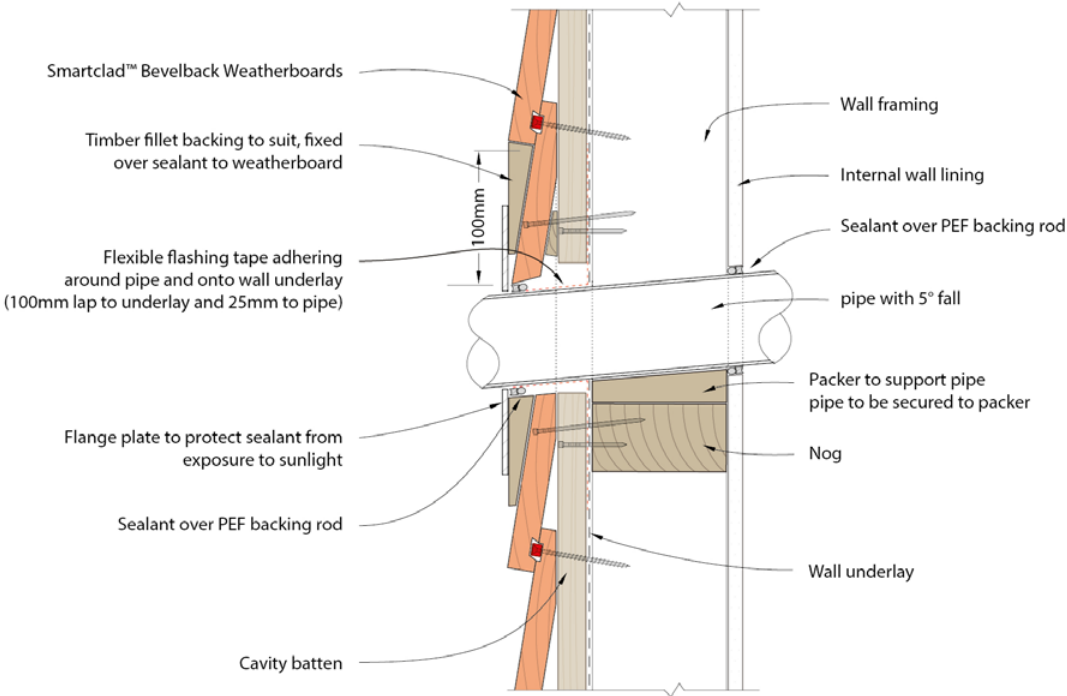

Figure 13: Bevelback — Pipe Penetration



CAVITY FIX

DIRECT FIX

Figure 14: Apron Flashing

CAVITY FIX

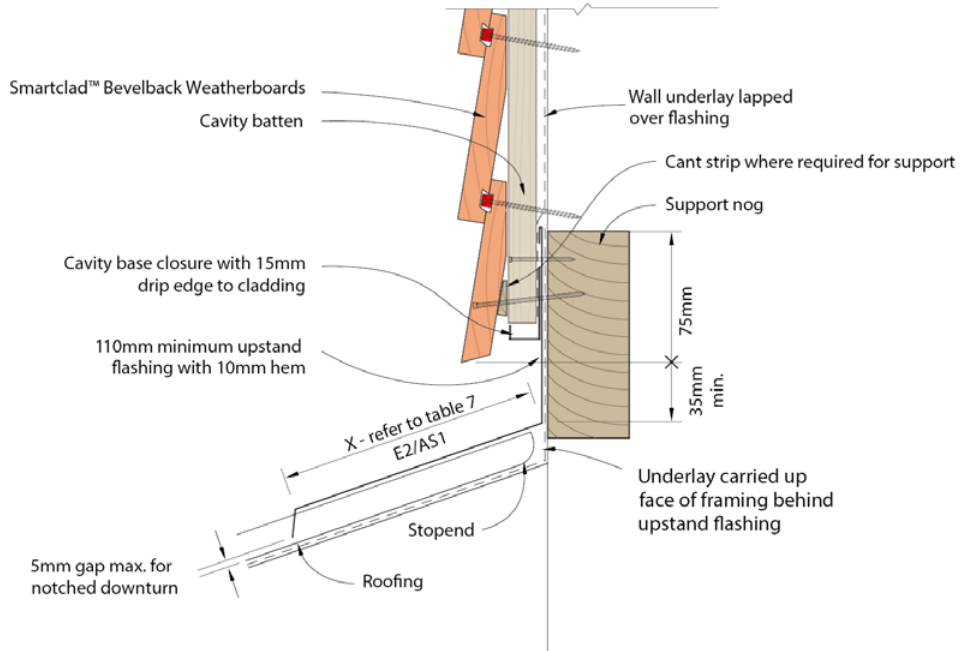

DIRECT FIX

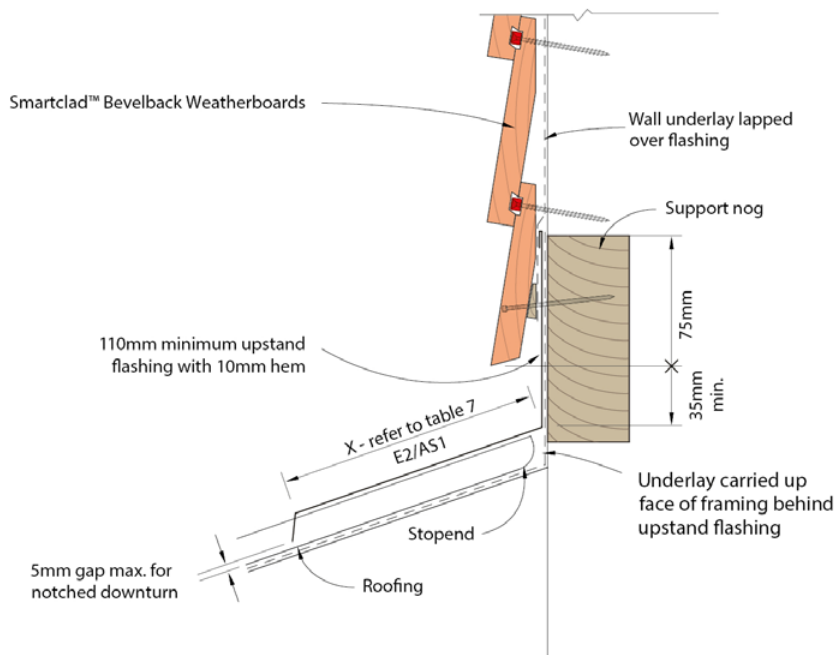
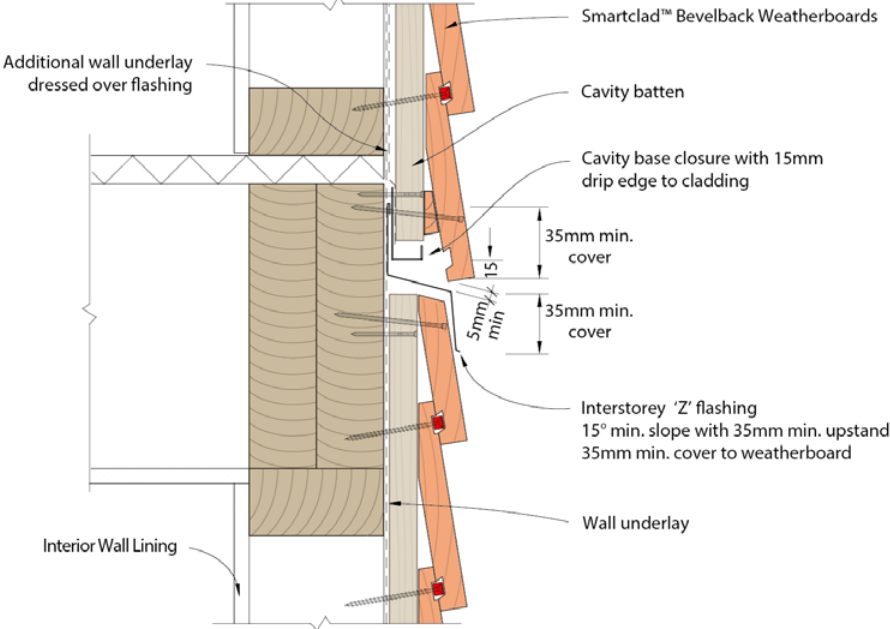
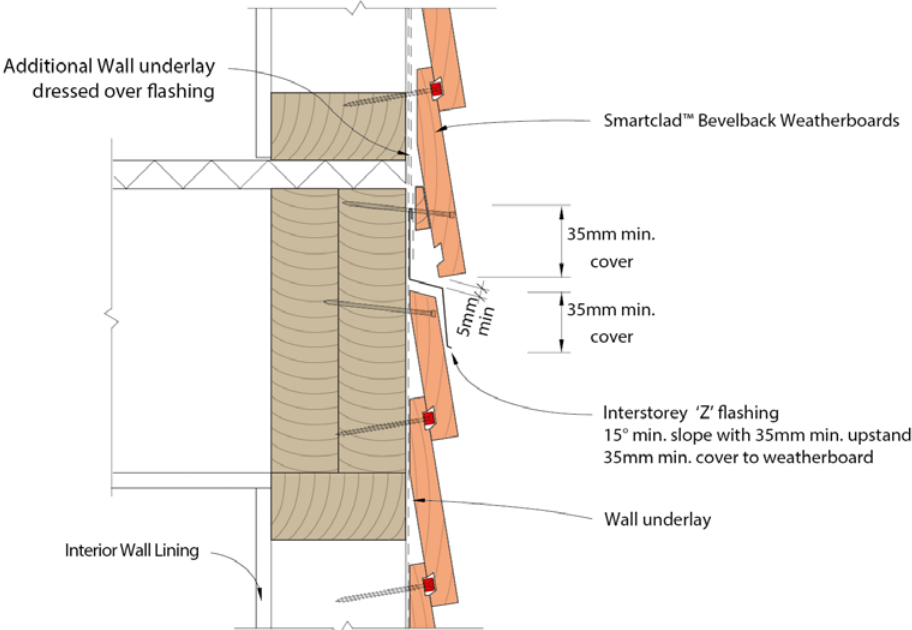

Figure 15: Bevelback – Inter-Storey Cavity Junction



NOTE: To be used to limit continuous cavities to the lesser of 2 storeys or 7 metres



NOTE: To be used to limit continuous cavities to the lesser of 2 storeys or 7 metres

CAVITY FIX

DIRECT FIX

Figure 16: Bevelback — Meter Box Head & Sill

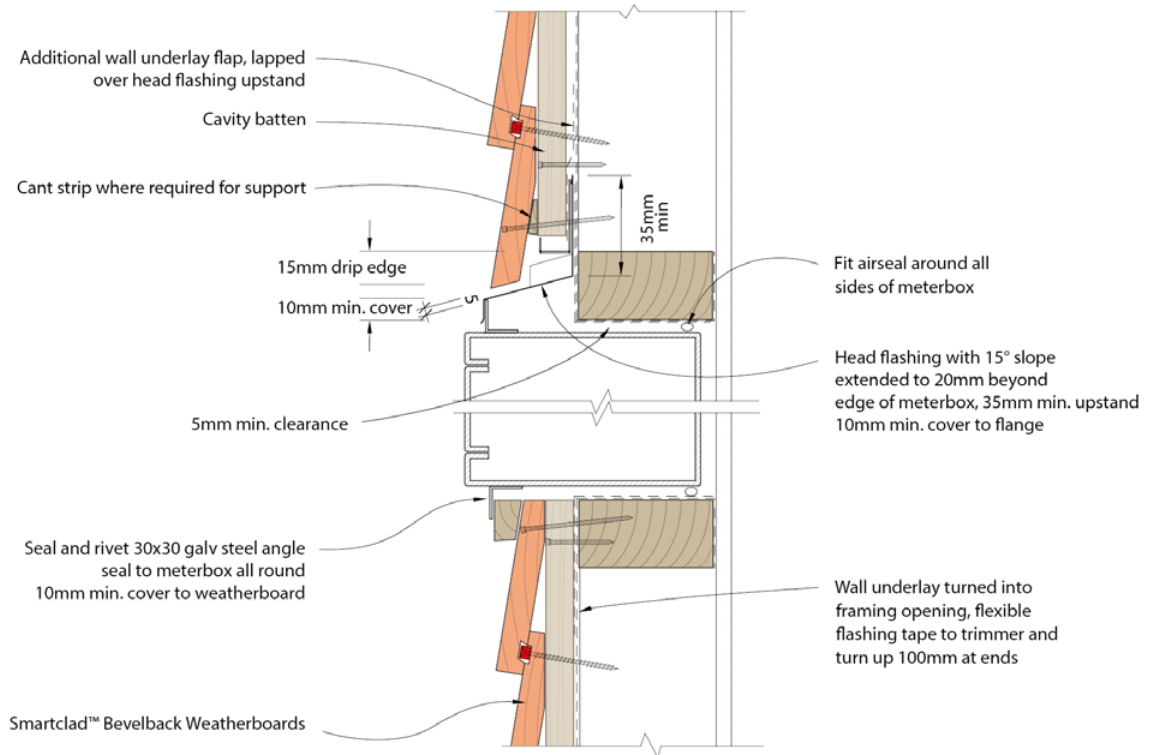

Note : Jamb detail similar to sill with angle to give cover to weatherboard with a Smartclad pre-scribed 40 x 10mm or 40 x 18mm scriber

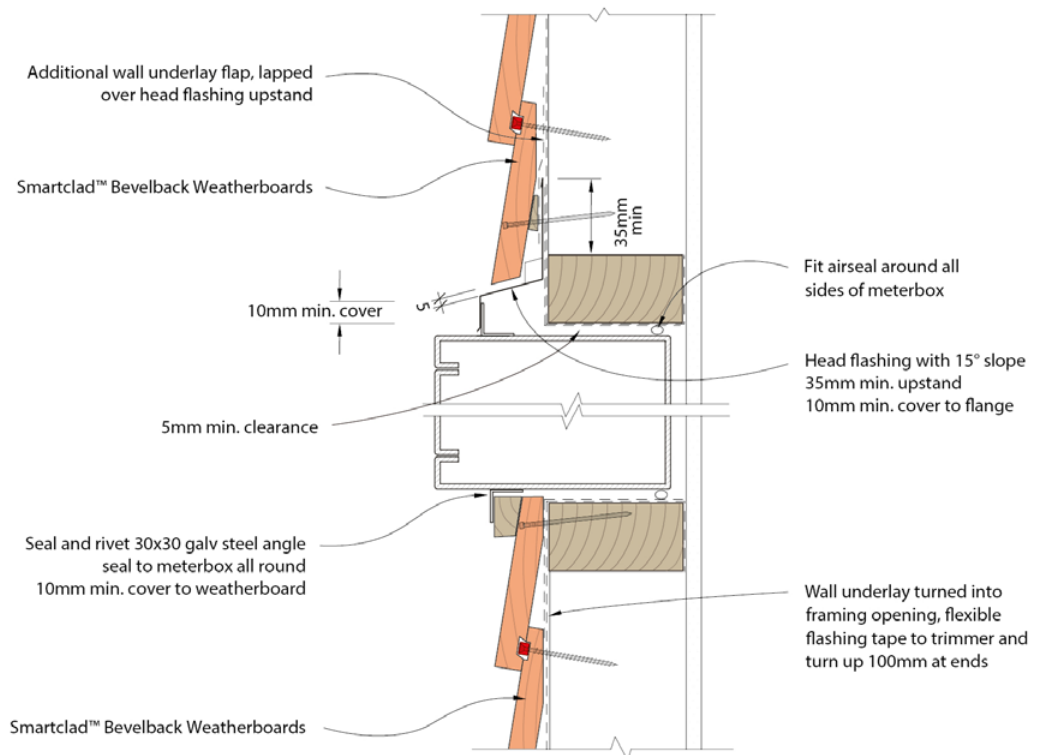

Note : Jamb detail similar to sill with angle to give cover to weatherboard with a Smartclad pre-scribed 40 x 10mm or 40 x 18mm scriber

CAVITY FIX

DIRECT FIX

Figure 17: Bevelback — Parapet Balustrade Cap Flashing

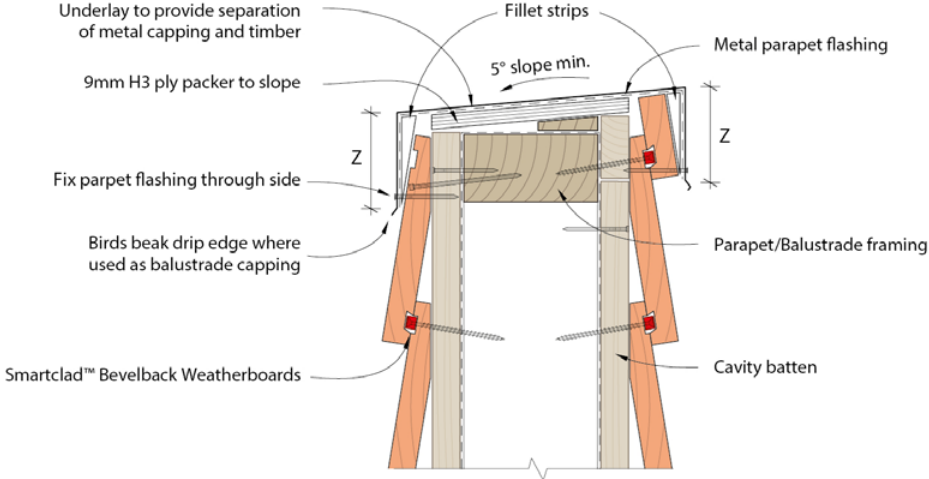

Note : Install flexible flashing tape and saddle flashing at junction with full height wall

Z = variable according to wind zone. Refer to E2/AS1 Table 7 parapet flashing to provide 50mm min. cover over weatherboards (70mm for very high wind zones)

CAVITY FIX

Figure 18: Bevelback — Parapet Balustrade Intersection With Wall: Moulding

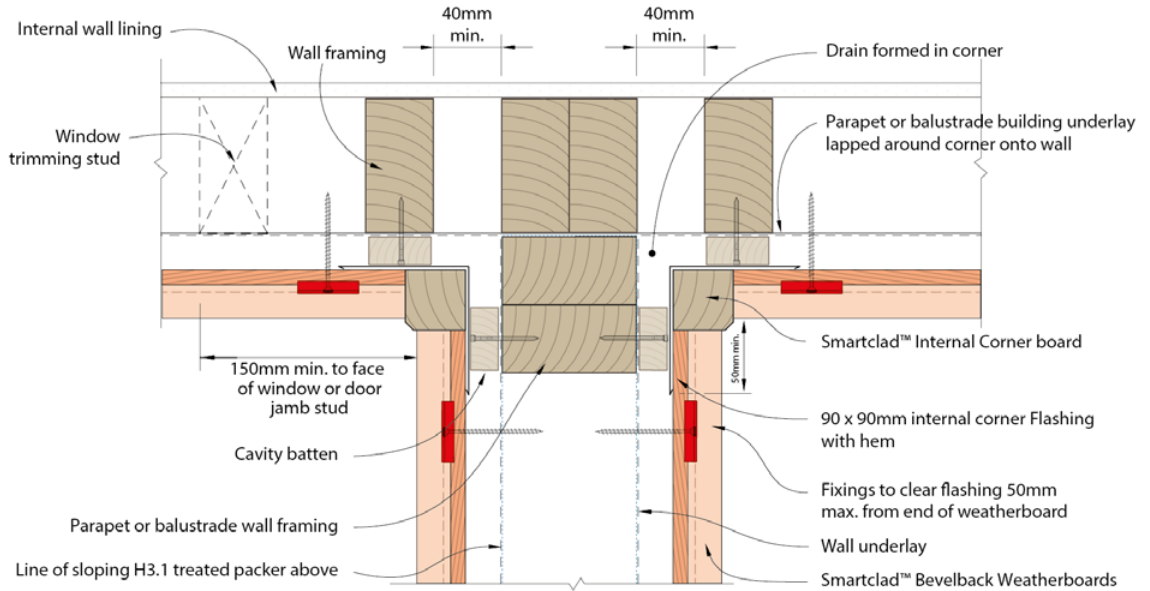
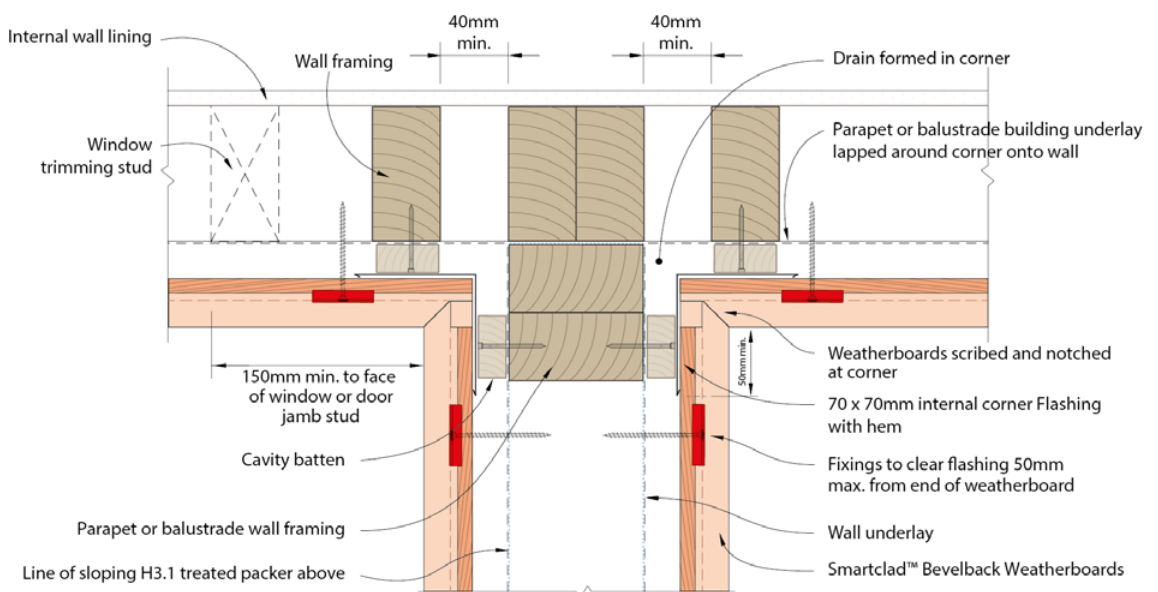

Figure 19: Bevelback — Parapet Balustrade Intersection With Wall — Scribed & Notched



CAVITY FIX

CAVITY FIX

Figure 20: Parapet Balustrade Intersection With Wall – Cavity Fix

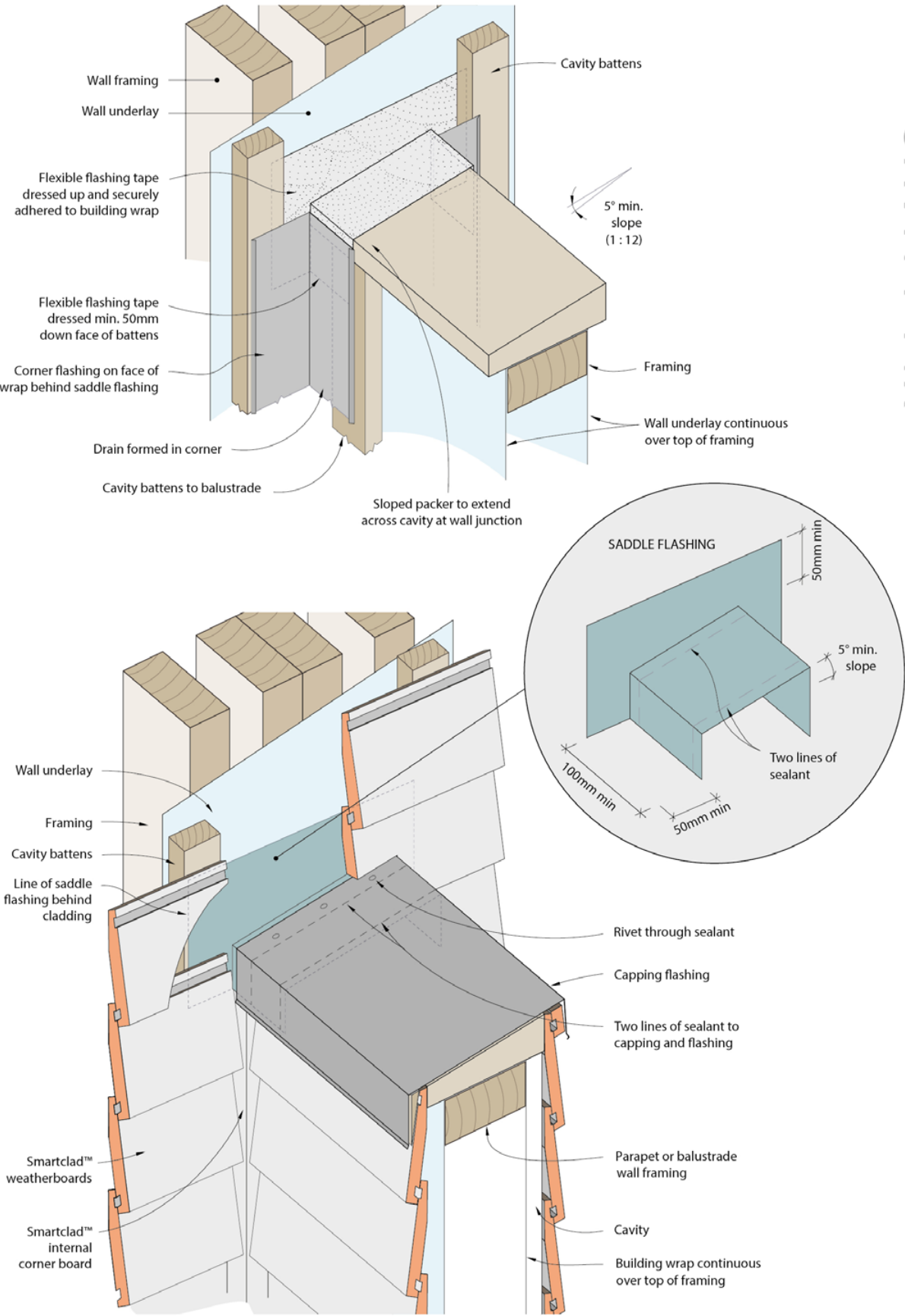
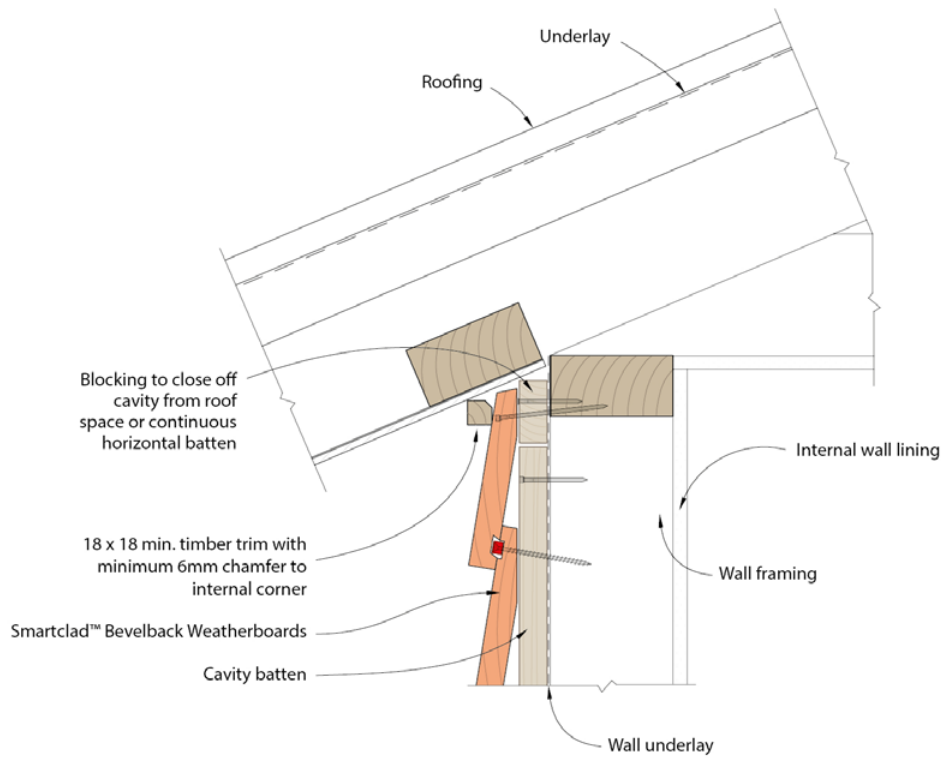

Figure 21: Bevelback — Top of Wall — Sloping Soffit

CAVITY FIX



DIRECT FIX

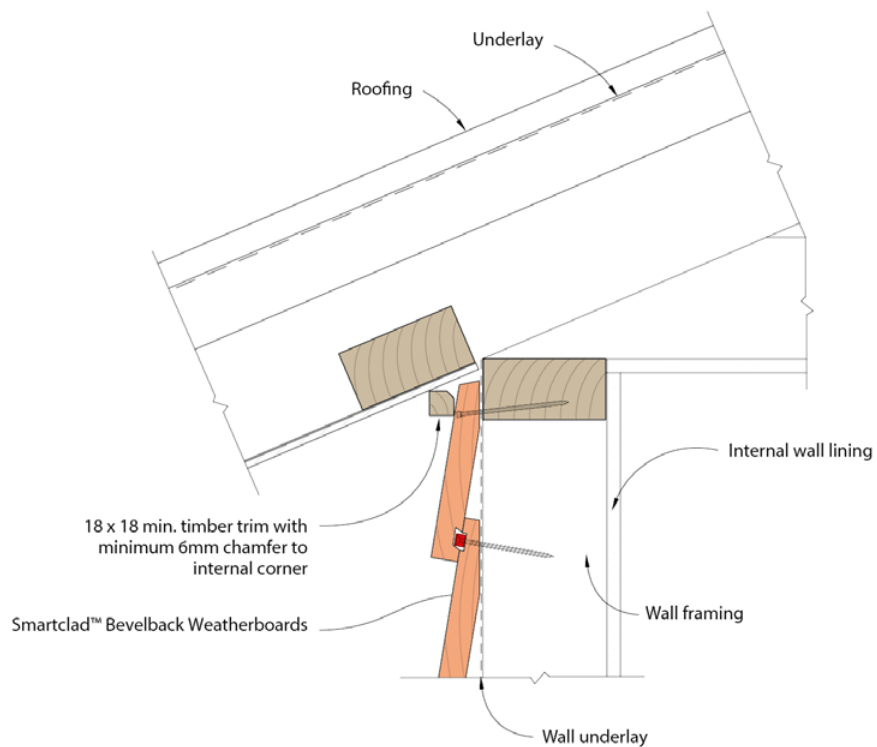
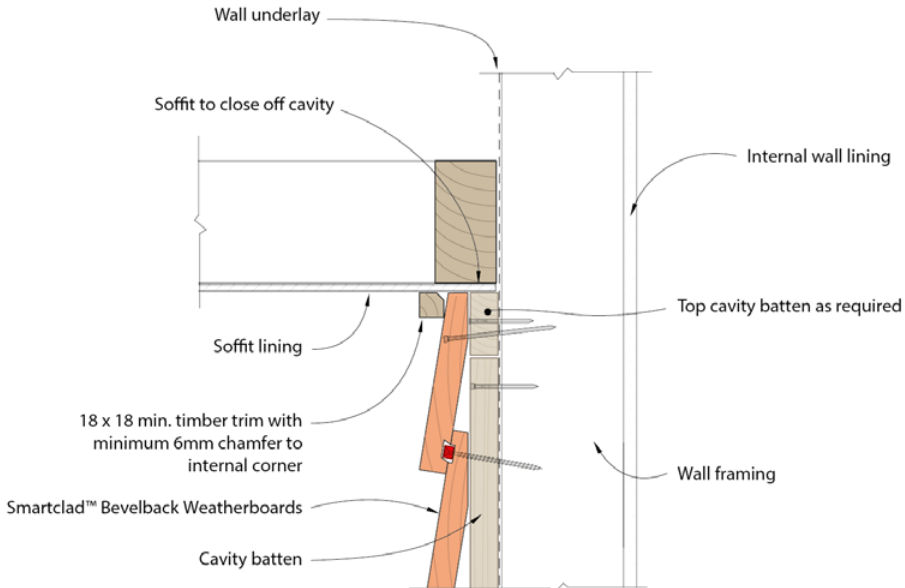
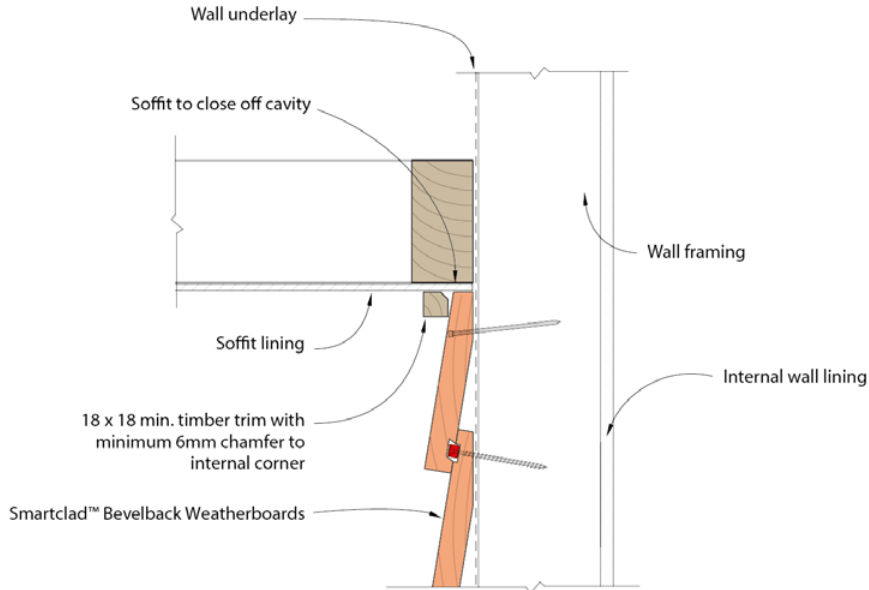

Figure 22: Bevelback — Top of Wall — Flat Soffit



CAVITY FIX



DIRECT FIX

Figure 23: Bevelback — Top of Wall — No Soffit

CAVITY FIX

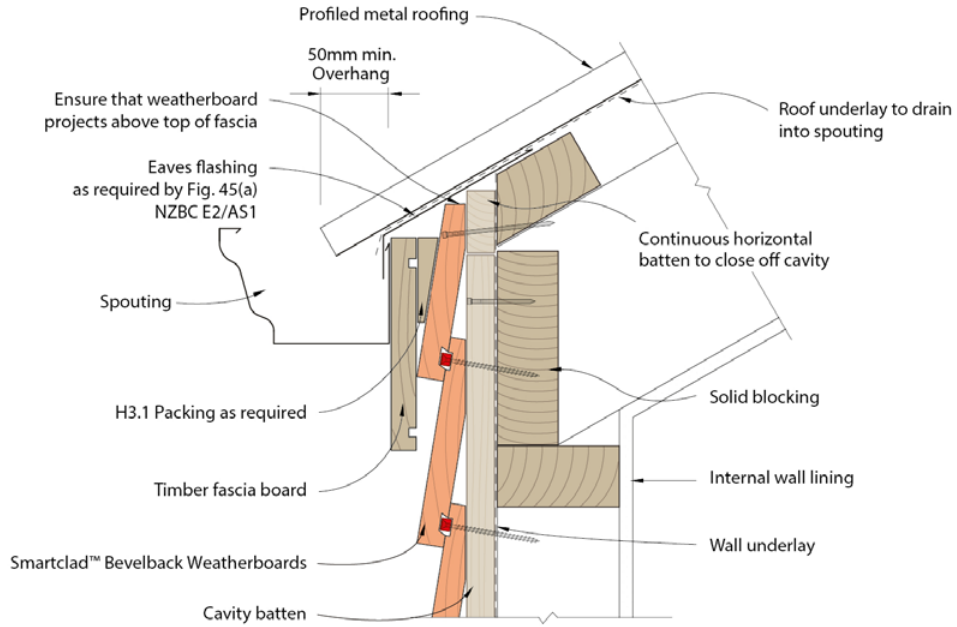

DIRECT FIX

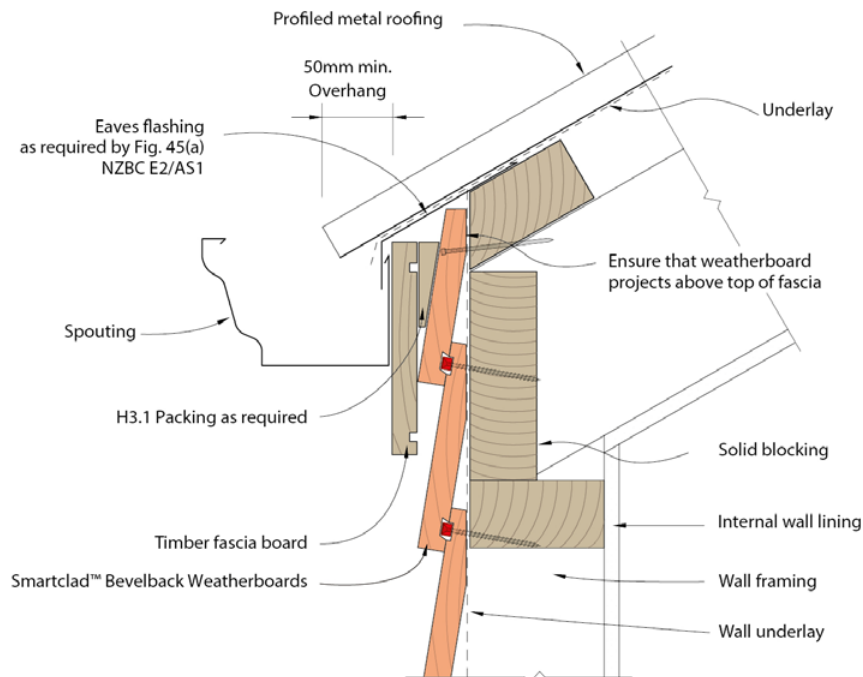
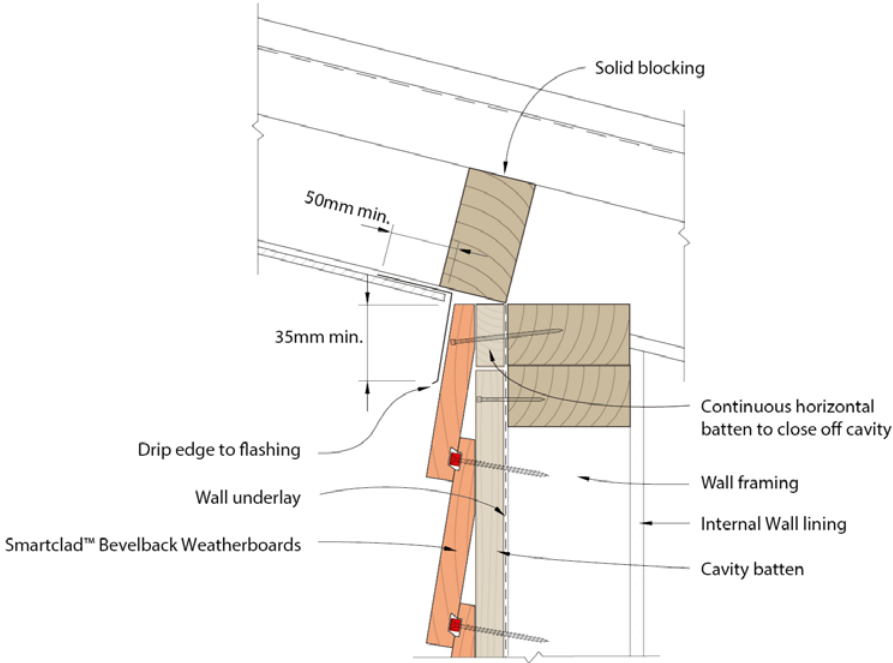
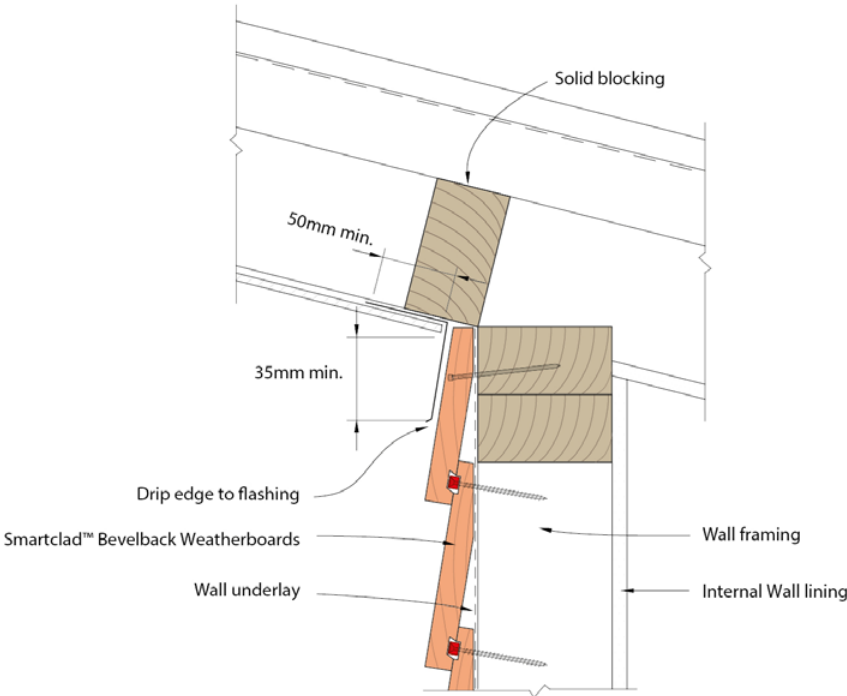

Figure 24: Bevelback — Top of Wall — Reverse Soffit



CAVITY FIX



DIRECT FIX

Figure 25: Bevelback – Window Sill

CAVITY FIX

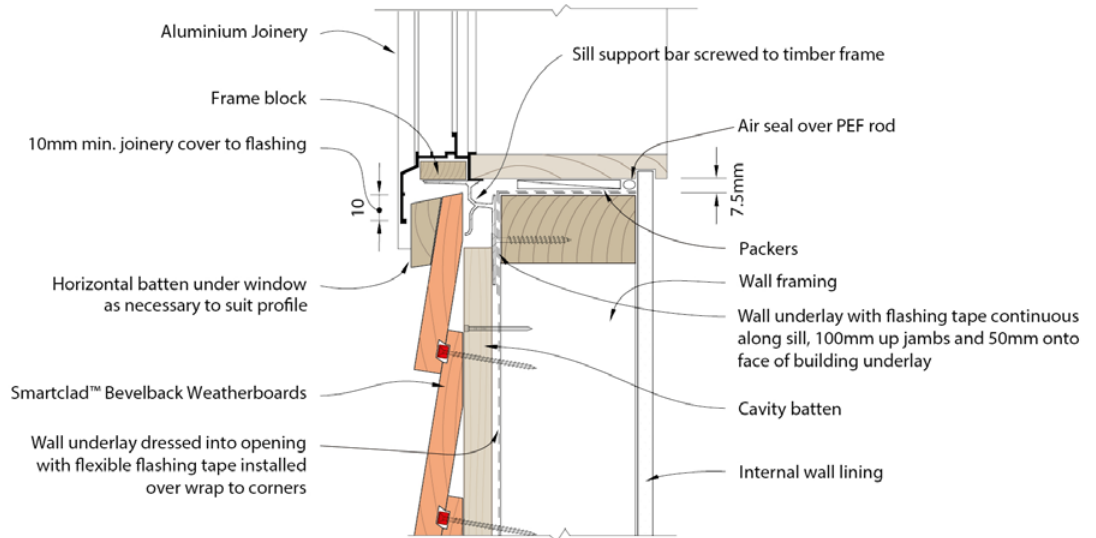

DIRECT FIX

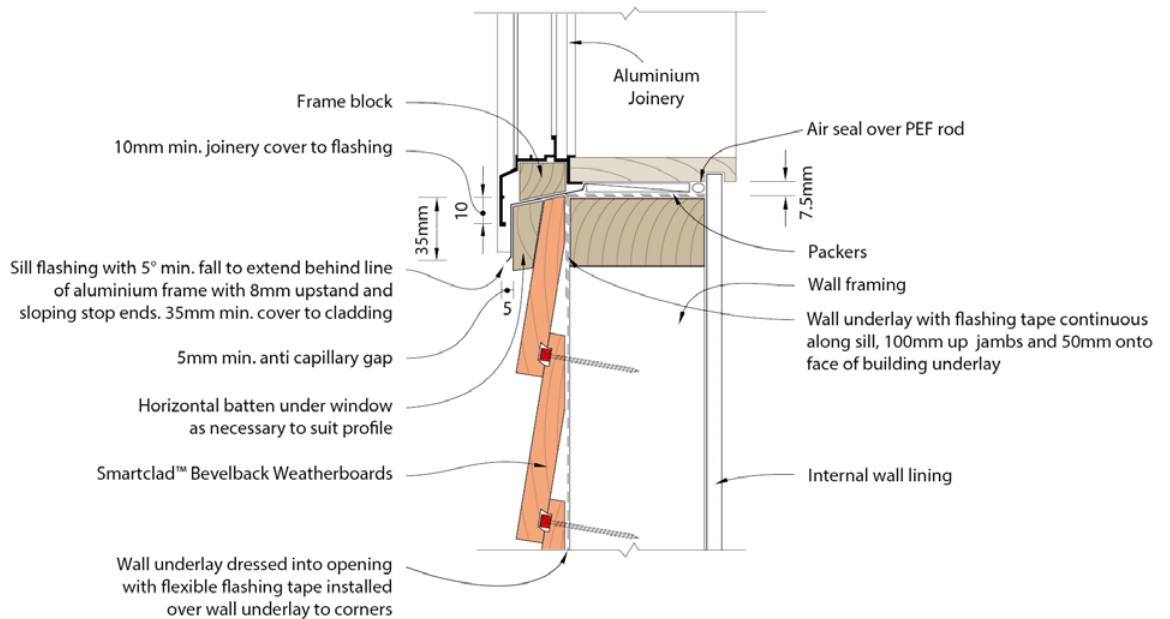
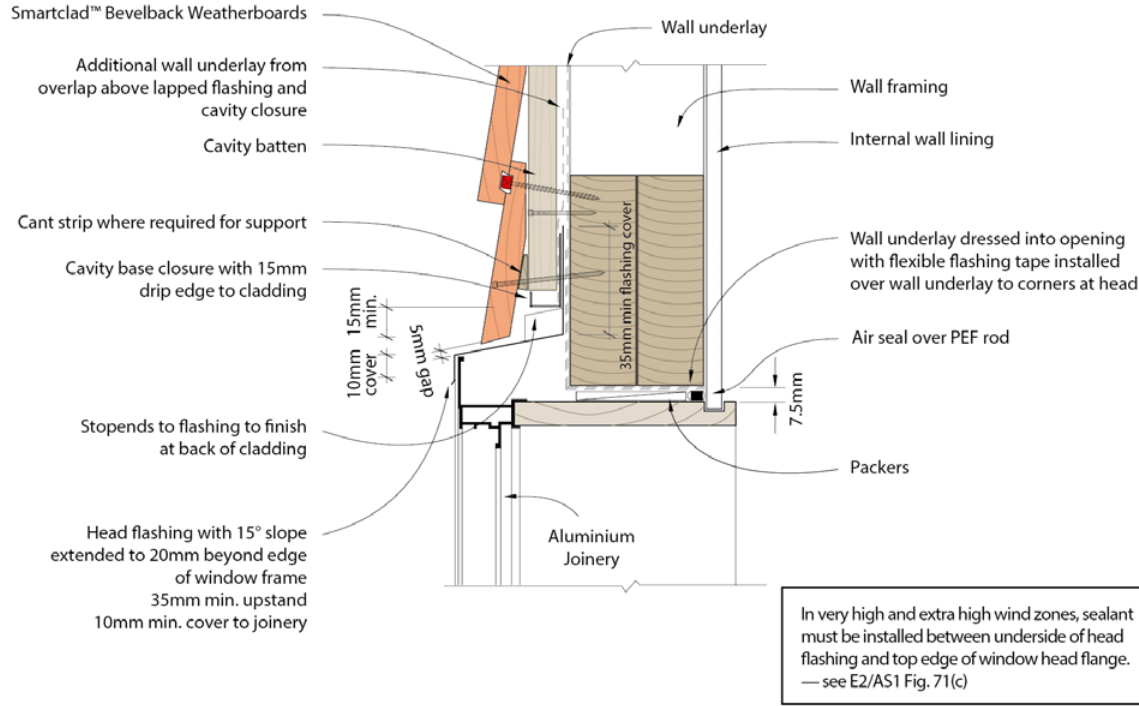
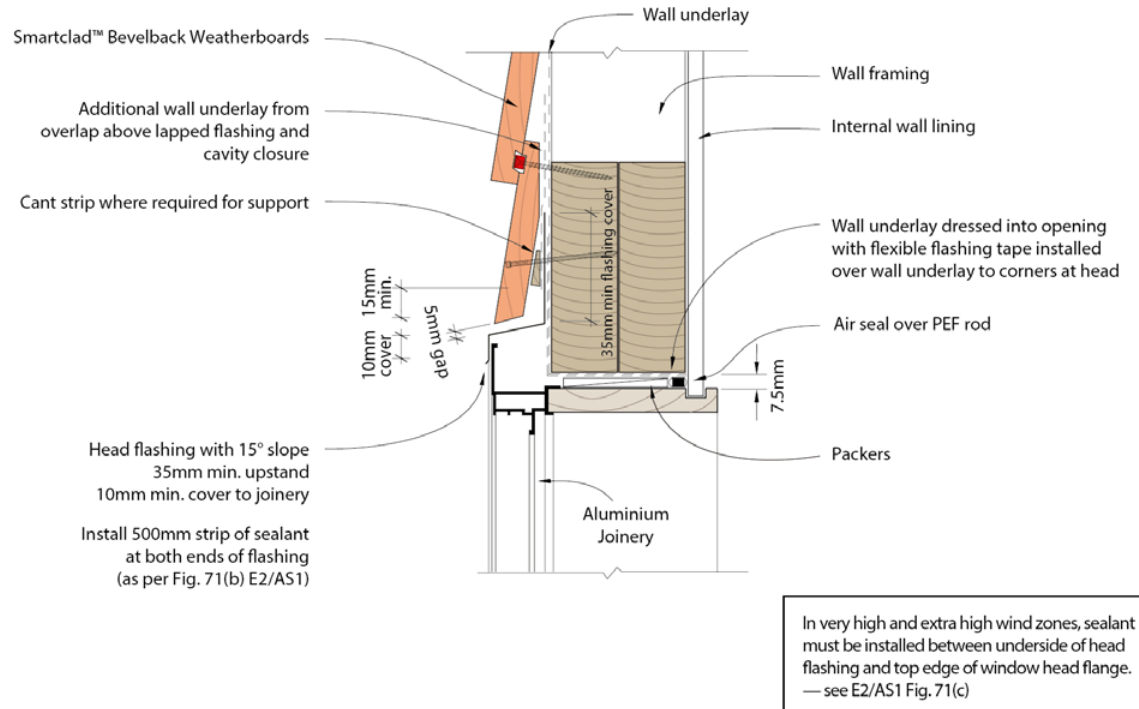

Figure 26: Bevelback — Window Head



CAVITY FIX



DIRECT FIX

Figure 27: Bevelback — Window Jamb

CAVITY FIX

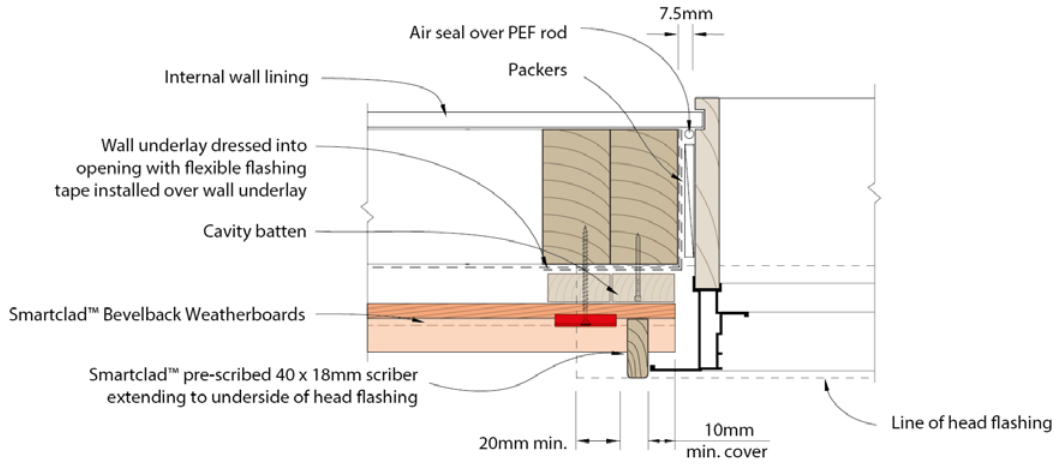

DIRECT FIX

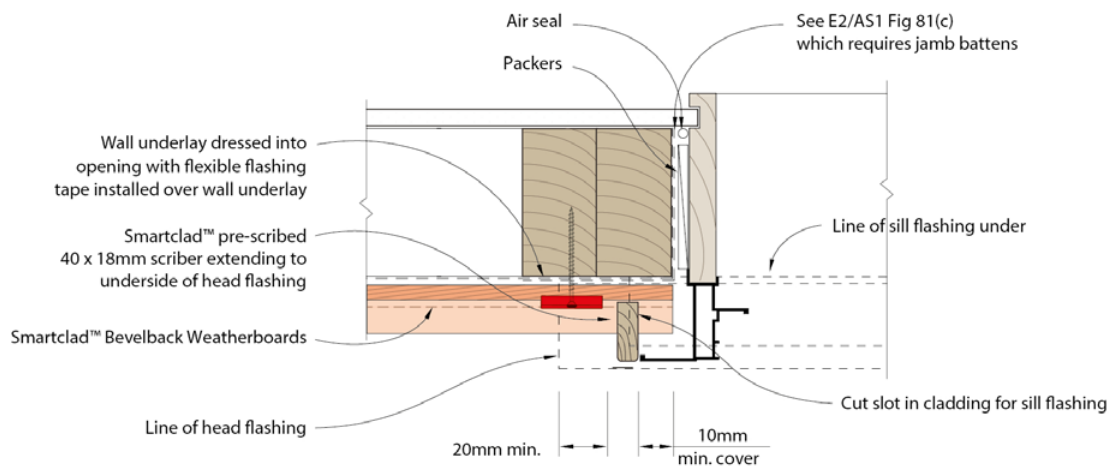
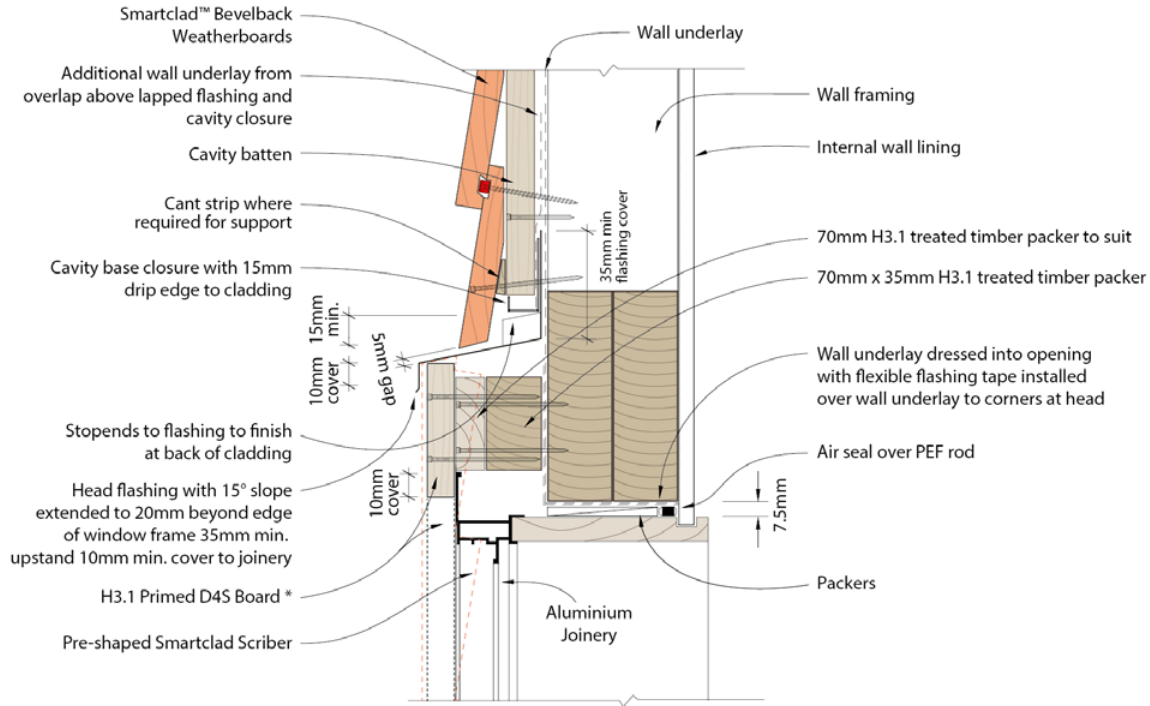

Figure 28: Window Head & Sill — With Facing Boards

Window Profile view: Head B



In very high and extra high wind zones, sealant must be installed between underside of head flashing and top edge of window head flange. — see E2/AS1 Fig. 71(c)

Window Profile View: Sill B

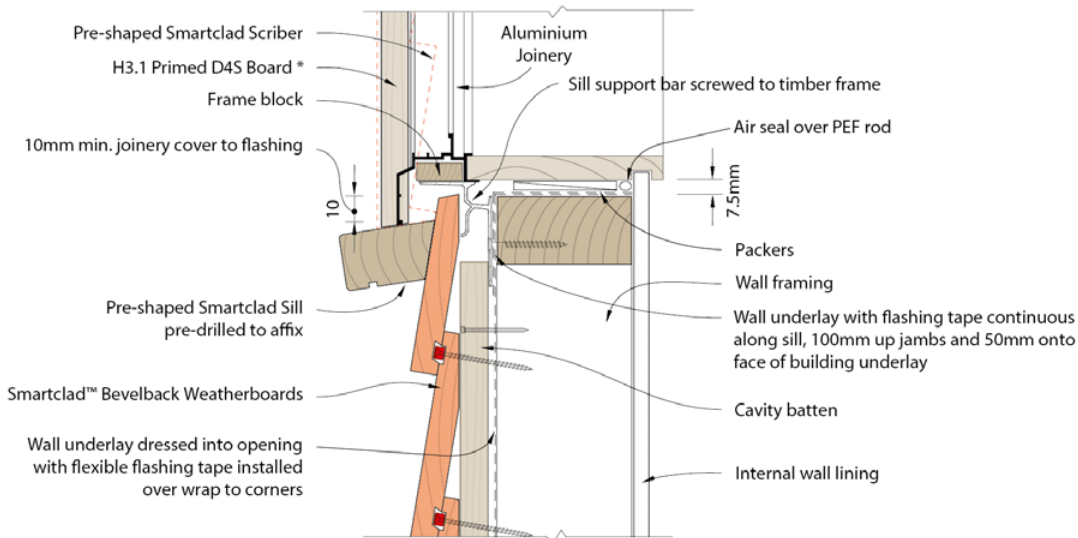

* Alternative solution is the Smartclad 88x34 or 42x34 facing boards which require no pre-cut scribe.

Figure 28a: Window Head & Sill – With Facing Boards

Window Front view: Head B

CAVITY FIX

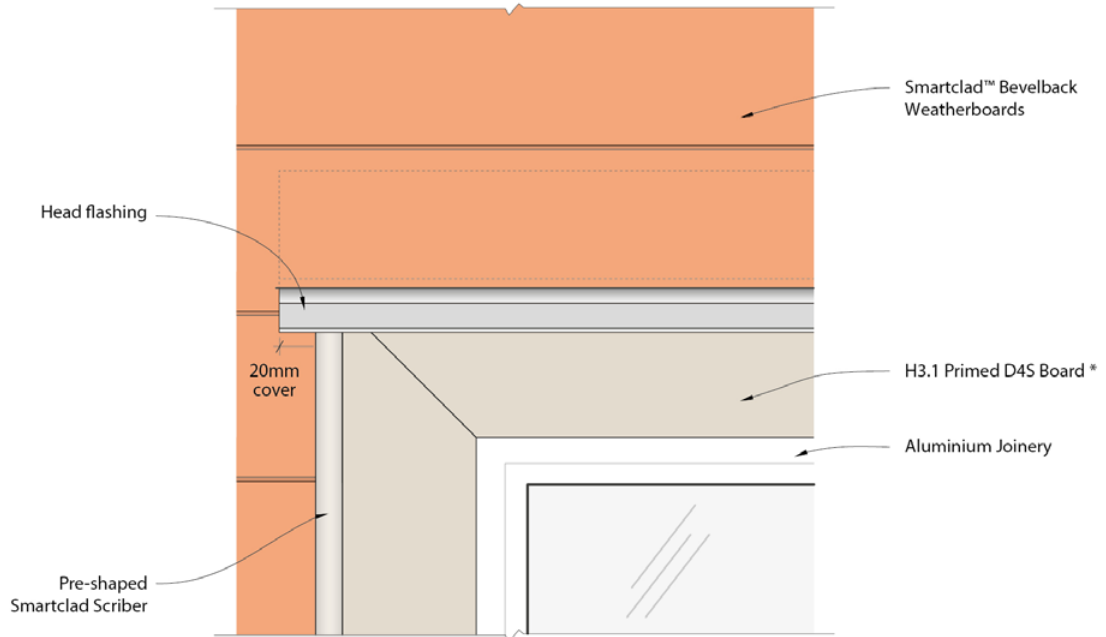

Window Front view: Sill B

CAVITY FIX

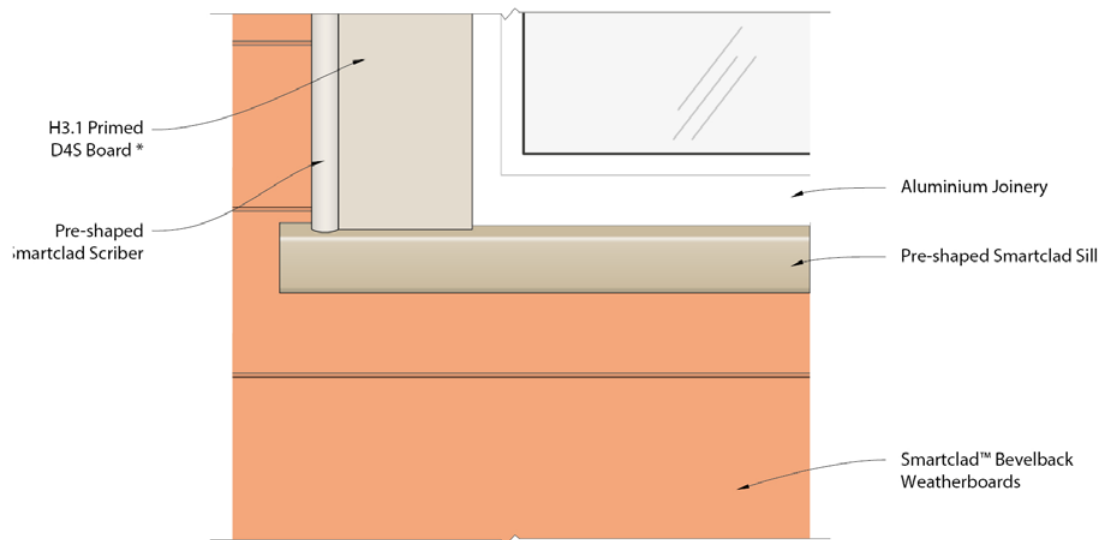
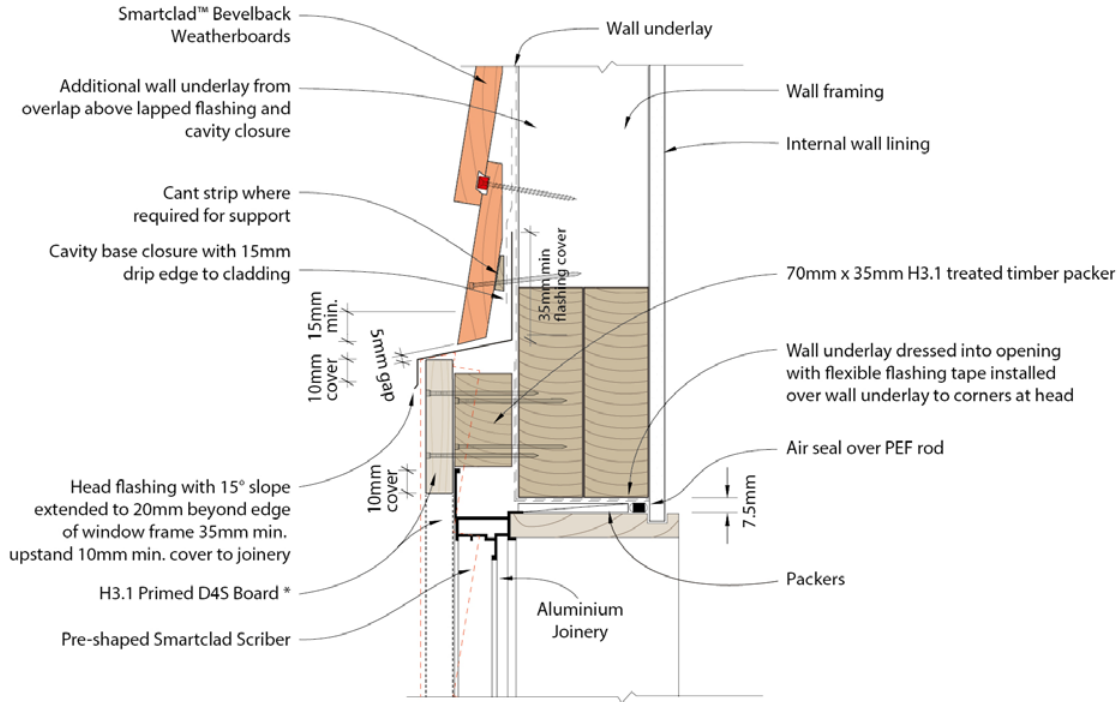

Figure 29: Window Head & Sill – With Facing Boards

Window Profile view: Head B



In very high and extra high wind zones, sealant must be installed between underside of head flashing and top edge of window head flange. — see E2/AS1 Fig. 71(c)

Window Profile view: Sill B

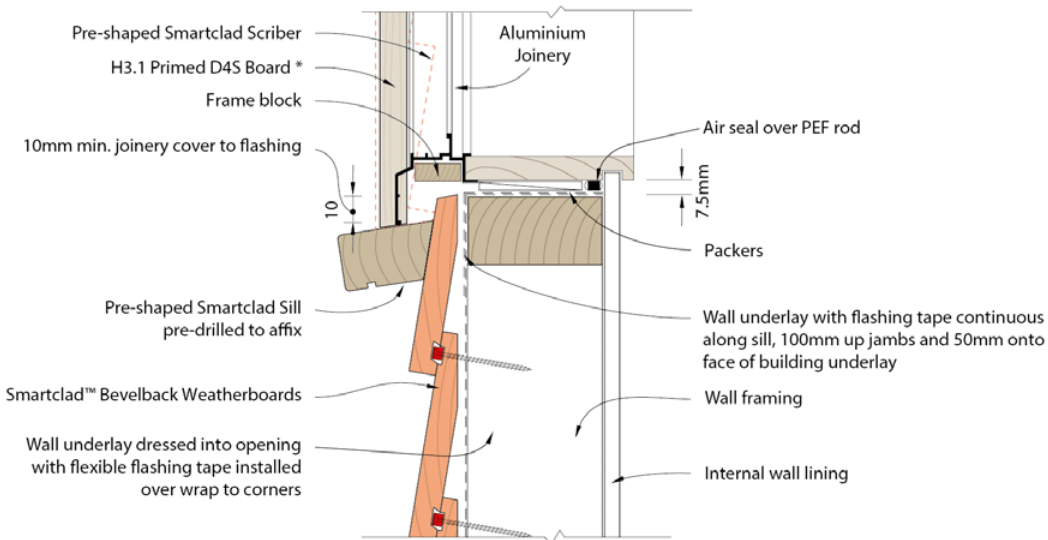

* Alternative solution is the Smartclad 88x34 or 42x34 facing boards which require no pre-cut scriber.

Figure 29a: Window Head & Sill – With Facing Boards

Window Front view: Head B

DIRECT FIX

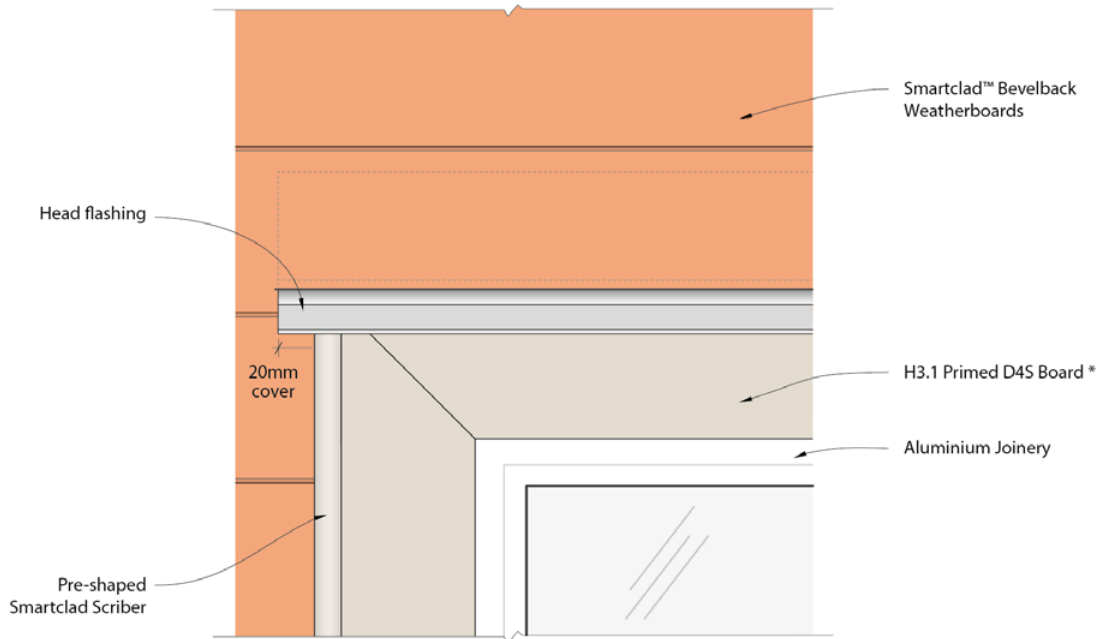

Window Front view: Sill B

DIRECT FIX

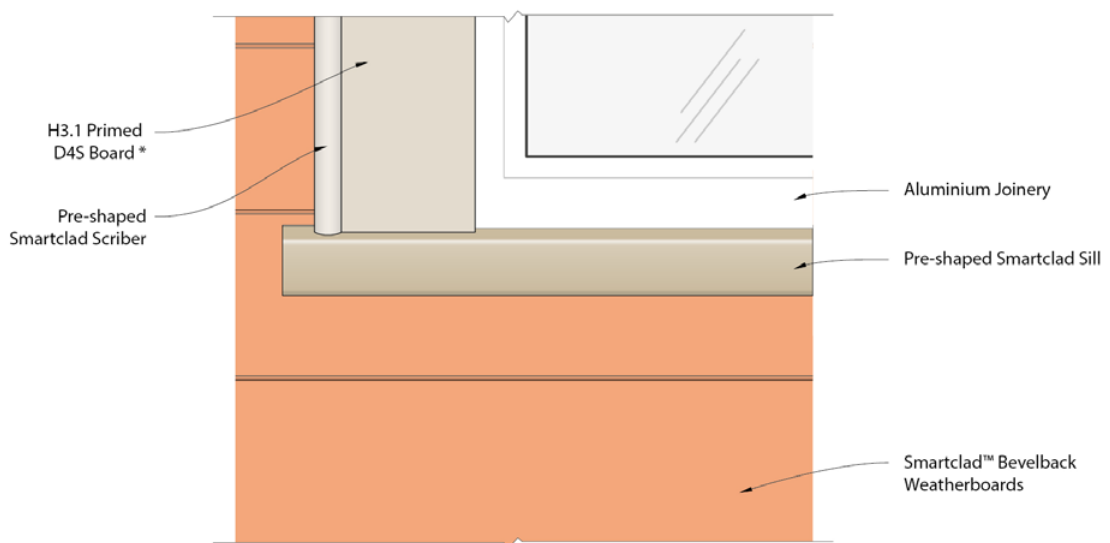

10. Weatherboard Profiles

SB140
Starter Board
140mm x 34mm

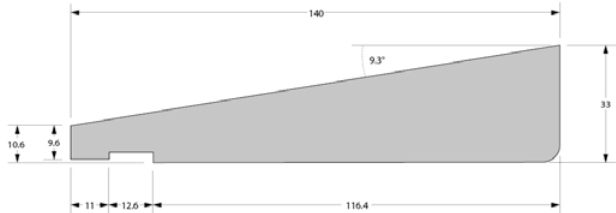

BBW140
Bevelback Weatherboard
140mm x 18mm

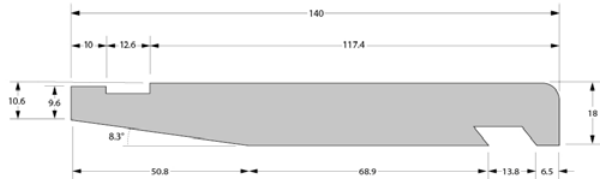

SB185
Starter Board
185mm x 32mm

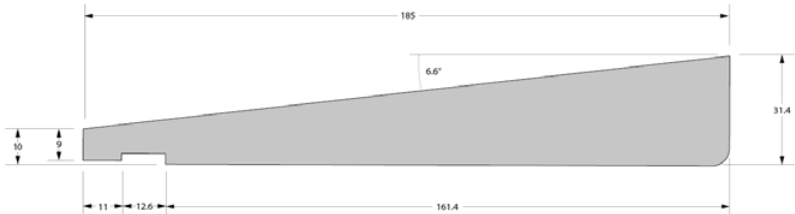

BBW185
Bevelback Weatherboard
185mm x 18mm

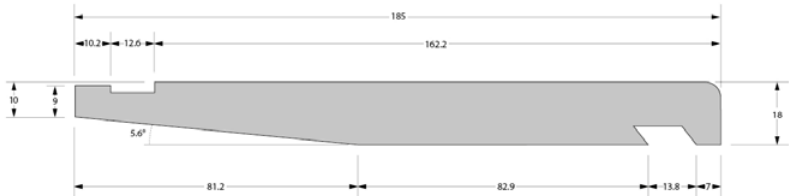

SCBC
Pre-shaped Box Corner (Female) 100mm x 18mm

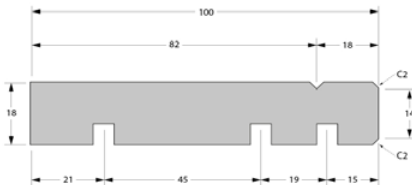

SCBC
Pre-shaped Box Corner (Male) 88mm x 18mm

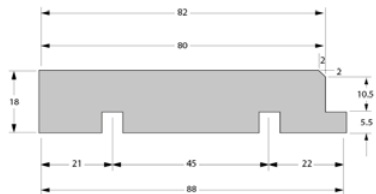

SCS
SmartClad Sill
65mm x 38mm

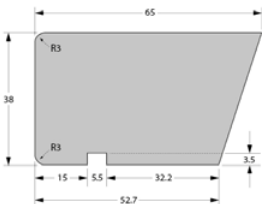

SISCS
Internal Corner Board
40mm x 40mm

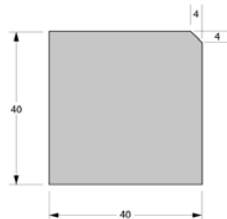

11. SmartClad Warranty

Definitions:

"Date of Purchase" means the date on which Purepine issues an invoice for the SmartClad product.

"Licensed Building Practitioner" has the meaning prescribed by the Licensed Building Practitioner Rules made pursuant to the Building Act 2004. "Purepine" means Purepine Mouldings Limited and its assignees.

"Purepine Premium Weatherboards and SmartClad weatherboards checklist" means the checklist to be completed by the customer and returned to Purepine after the cladding is completed.

"Resistant" means resistant to the extent set out in SmartClad product literature at the time the SmartClad products were installed.

"SmartClad" means Purepine's SmartClad weatherboard cladding system, clips and preformed component products.

"SmartClad Technical Manual" means the SmartClad technical manual as updated from time to time available from Purepine's website www.smartclad.co.nz or by phoning toll-free 0800 768 253 during normal working hours.

"Warranty" means the Warranty given below under the heading "Warranty".

"Warranty Conditions" means the conditions and limitations listed below under the heading "Warranty Conditions".

Warranty

Subject to the Warranty Conditions, for a period of 15 years from the Date of Purchase, Purepine warrants that SmartClad will be:

- free from manufacturing and production defects;
- resistant to cracking;*
- resistant to rotting;*
- resistant to damage from borer attacks;* and
- resistant to damage from termite attacks. *

* **Note:** "Resistant" means resistant to the extent set out in the SmartClad product literature at the time of installation.

Warranty Conditions

This Warranty is strictly subject to the following conditions and limitations. Failure to comply with these conditions may result, at the sole discretion of Purepine, in a Warranty claim being rejected.

1 Installation

- 1.1 SmartClad must be installed by competent Licensed Building Practitioner.
- 1.2 SmartClad must be installed strictly in accordance with the SmartClad Technical Manual using only SmartClad products.

- 1.3 If the SmartClad Technical Manual does not contain the necessary installation instructions, then SmartClad must be installed in accordance with best trade practices as determined by the relevant local authority and, if prudent, as determined by the designer of the structure to which SmartClad is being installed.

- 1.4 Non-SmartClad products used in conjunction with or alongside SmartClad must be installed/ applied strictly in accordance with the relevant manufacturer's installation specifications and guidelines or best trade practice if such specifications and guidelines are not available.

- 1.5 The structure or building in which SmartClad has been incorporated must be designed and constructed in accordance with the New Zealand Building Code current at the time of installation, the Building Act 2004 and all rules, standards, and regulations issued thereunder and all consents issued by local authority for the structure.

2 Maintenance

- 2.1 SmartClad must be maintained strictly as recommended by the SmartClad Technical Manual.
- 2.2 Non-SmartClad products used in conjunction with or alongside SmartClad including (but not limited to) coating and jointing systems, must be maintained strictly in accordance with the relevant manufacturers installation specifications and guidelines or best trade practice if such specifications and guidelines are not available.

3 Timing of Claim

- 3.1 The Purepine Premium weatherboards and SmartClad weatherboards checklist must be completed and returned to Purepine on completion of cladding and no later than 30 days of a defect becoming apparent.
- 3.2 Claims under the Warranty must be received in writing by Purepine within 30 days of the date the deficiency or fault became or should have become apparent to a building owner acting reasonably.
- 3.3 Purepine will not be liable for claims made after the time frame specified in 3.1 has expired.
- 3.4 Except as otherwise permitted by law, and without limiting anything else contained herein, all claims against Purepine must be made through the supplier of SmartClad.

4 Privity of Contract

- 4.1 The Warranty is for the benefit of the customer named on Purepine's purchase invoice only.
- 4.2 Without limiting clause 4.1, this Warranty is not transferable to subsequent owners or occupiers of the structure to which SmartClad is installed.

5 Remedies

- 5.1 Upon receipt of a valid Warranty claim, Purepine will in its sole discretion elect to either:
- 5.1.1 supply replacement SmartClad for installation by the customer; or
 - 5.1.2 undertake rectification works on the affected SmartClad; or
 - 5.1.3 pay for the cost of the replacement or rectification of the affected SmartClad.
- 5.2 Other than as specified in clause 5.1, no other remedies are available to the customer under this Warranty.
- 5.3 The customer acknowledges and agrees that replacement product and/or remedial works may result in colour variations between the original and replacement SmartClad due to the effects of weathering and changes to SmartClad materials over time. Purepine shall not be liable to the customer for any such colour variations.

6 Limitation of Liability

- 6.1 Other than as stated herein, Purepine will not be liable for any losses, liabilities, costs, charges, expenses, damages whether direct, indirect or consequential, howsoever arising as a result of a defect or deficiency or fault in SmartClad.
- 6.2 For clarity, but without prejudice to the generality of clause 6.1, Purepine will specifically not be liable for any losses, liabilities, costs, charges, expenses, damages whether direct, indirect or consequential, arising from or in any way attributable to poor workmanship, poor design, poor detailing, structural settlement, structural movement, movement of materials to which SmartClad is attached, improper structural design, acts of God including but not limited to earthquakes, cyclones, floods or other severe weather conditions, efflorescence, performance of paint or coatings applied to SmartClad, normal wear and tear, growth of mould, mildew fungi, bacteria, or any attachment of any organism on the surface of SmartClad (whether on the exposed or unexposed surfaces). This Warranty does not exclude or modify any legal rights a customer may have under the Consumer Guarantees Act 1993.
- 6.3 To the fullest extent allowed by law, all warranties, conditions, liabilities and obligations expressed or implied by law other than those specifically set out in this Warranty are excluded. Without limiting the generality of the foregoing, unless otherwise specified in writing at the Date of Purchase, Purepine assumes no liability for SmartClad being fit for any particular purpose.
- 6.4 Failure to complete and return the Purepine Premium weatherboards and SmartClad weatherboards checklist may void warranty.

12. Disclaimer

The recommendations contained in this document are based on good building practice, but are not an exhaustive statement of all relevant information. The successful performance of the system relies on many factors outside the control of Purepine Mouldings Limited such as the quality of workmanship and design.

Purepine Mouldings Limited shall not be liable for the recommendations made in its literature and the performance of the system including conformance with the NZBC, regulations and standards. It is the responsibility of the building designer to ensure that the details and recommendations provided are suitable for the intended project and that the design is executed appropriately.

13. Contact Details



Purepine Mouldings Limited

Tel: +64 7 573 9161
info@purepine.co.nz
274 Jellicoe Street, Te Puke 3119
www.purepine.co.nz



SMART'CLAD™

The intelligent timber weatherboard

For more information call
the tollfree help line **0800 768 253**
or visit **www.smartclad.co.nz**

