

CF SHINGLE Panels (Figure 12)

[CF = Concealed Fastening]

Units of Measurement = Millimetres (mm)

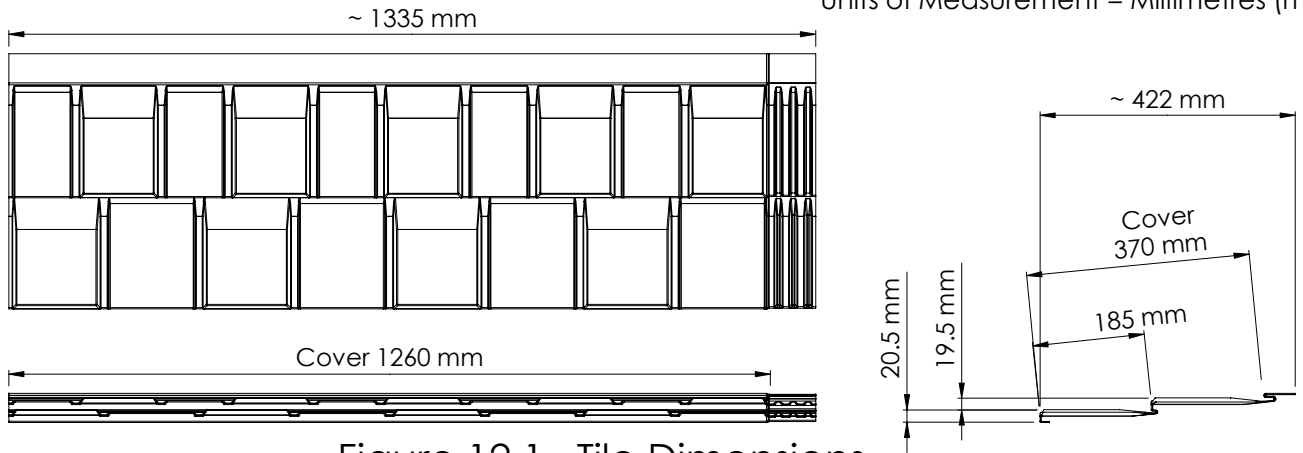

Figure 12.1 Tile Dimensions

FASTENERS. Typically 5 per Panel.
The quantity and type of fastener is dependent on local requirements.

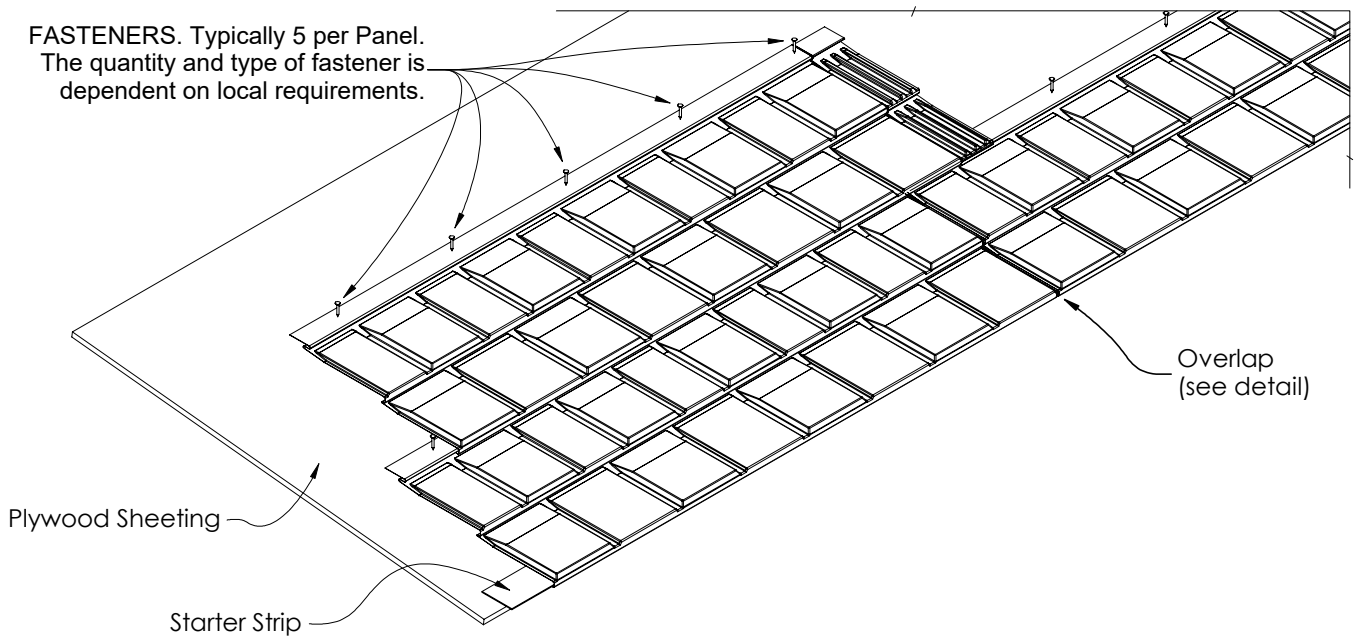

Figure 12.2 Fastening Detail

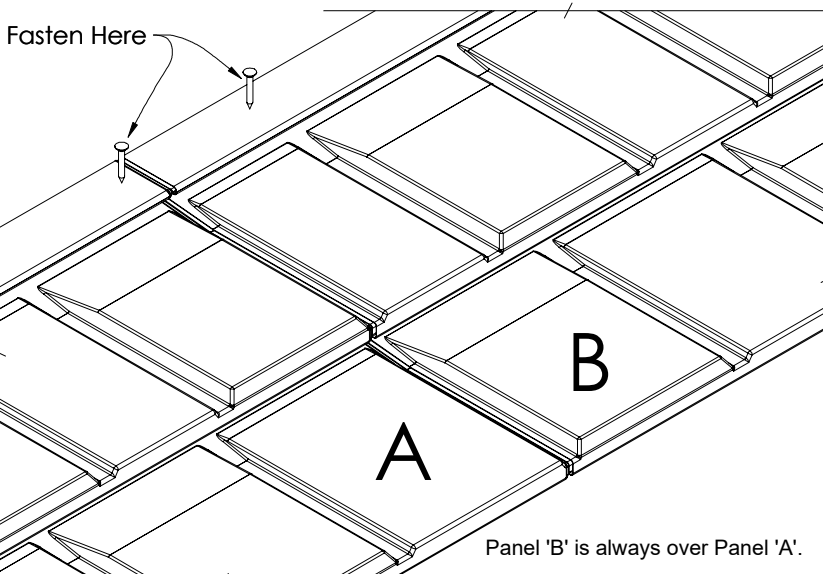

Figure 12.3 Overlap Detail

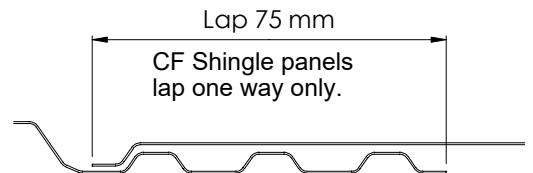

Figure 12.4 Side Lap Detail

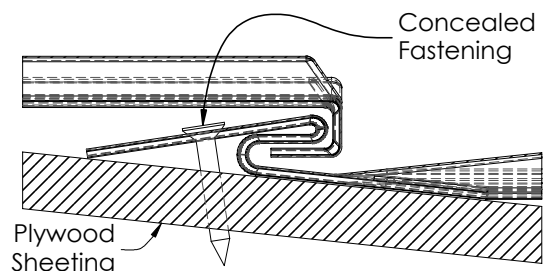
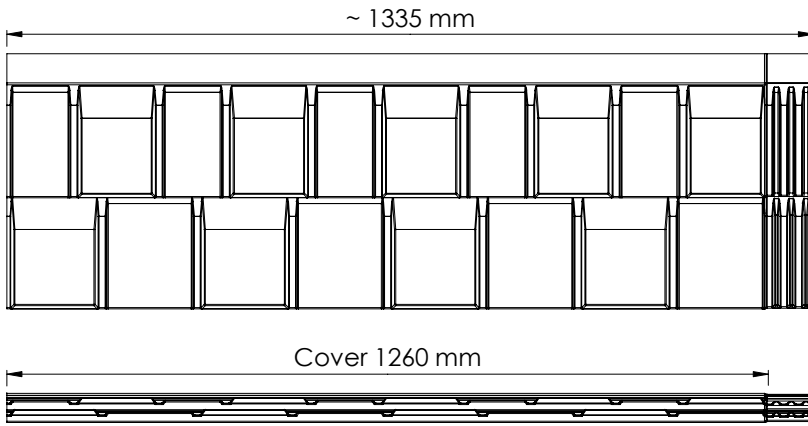

Figure 12.5 Nose Lap Detail

SHINGLE CF Tile (Figure 12)

[CF = Concealed Fastening]

Units of Measurement = Millimetres (mm)



Tile Dimensions

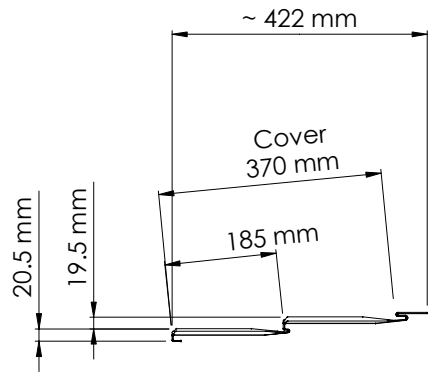

FASTENERS. Typically 5 per Tile.
The quantity and type of fastener is dependant on local requirements

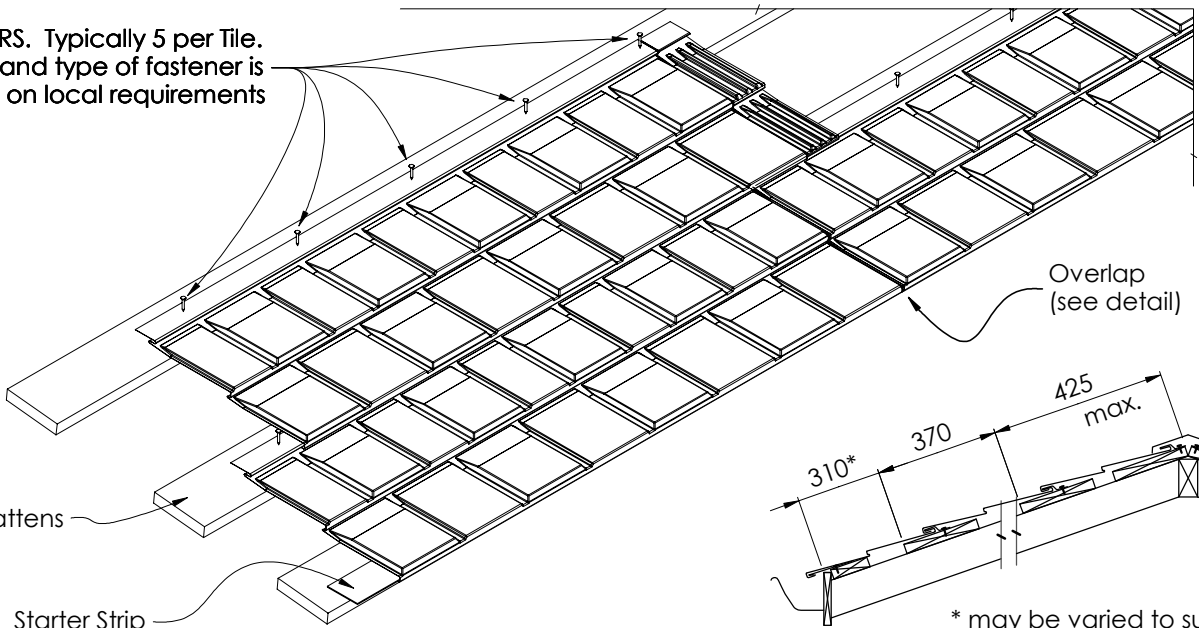

Fastening Detail

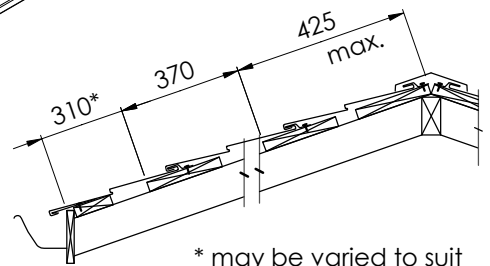

* may be varied to suit rain water goods

Batten Detail

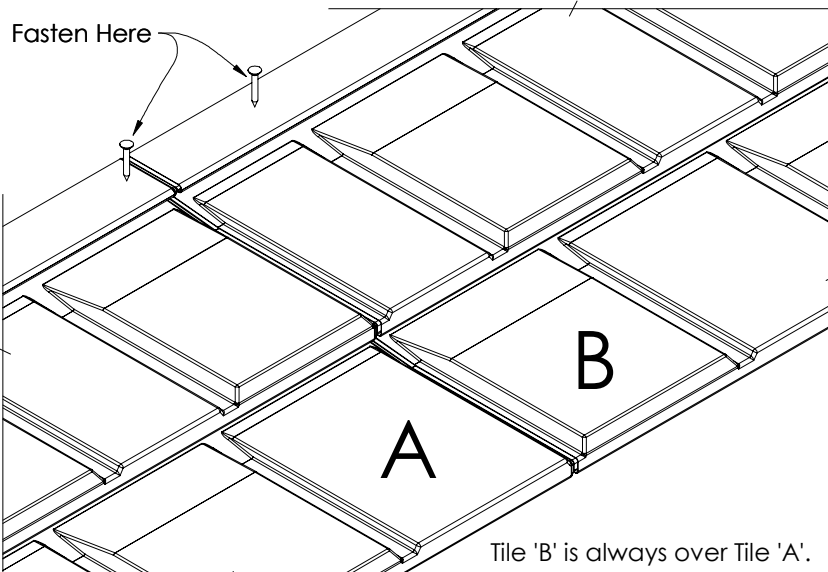

Overlap Detail

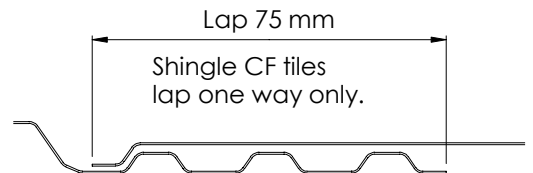

Side Lap Detail

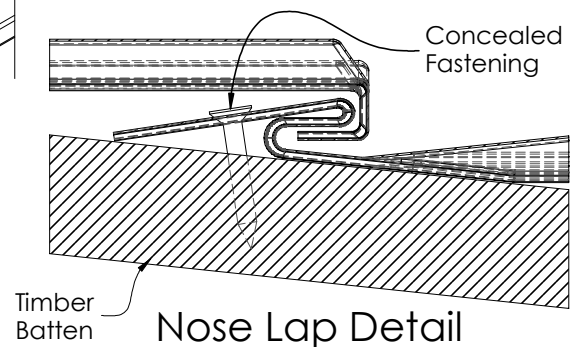

Nose Lap Detail