

301

# Awning Window Span Charts

REV#	DESCRIPTION	DATE
-	-	00/2013
-	-	00/2013
-	-	00/2013
-	-	00/00/2013

SPAN CHART

SCALE	NTS	
	NAME	DATE
DRAWN	ADM	05/10/17
CHECKED		



DRAWING No.  
300 SERIES SP

SECTION(S):  
G326

DESCRIPTION:  
TRANSOM / MULLION

DATA:  
MOMENT OF INERTIA - 48681 mm<sup>4</sup>

DEFLECTION MAX:  
15mm

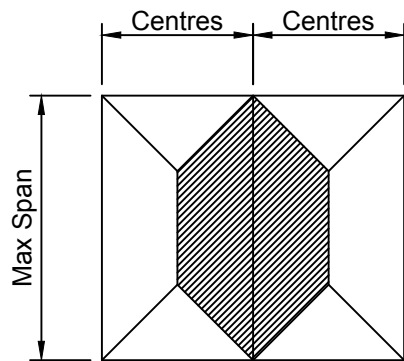
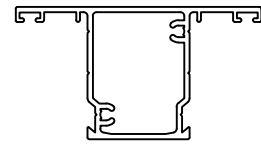

MULLION DATA - Mullion spacing and span calculations are to the current NZS 4211:2008  
Tables shall be used only where no Specific Design wind pressures are specified by the designers. The data provided is given for guidance only and the manufacturer takes no responsibility for incorrect interpretation. It is recommended that a qualified designer be consulted before fabrication.  
SPAN (m) - ULTIMATE (UWP) - SERVICEABILITY (SWP)  
SPAN / DEFLECTION (SPAN / DEF) = RESIDENTIAL 200 min

WIND ZONE :		LOW	MEDIUM	HIGH	VERY HIGH	EXTRA HIGH
SPAN / DEF. :		200	200	200	200	200
MULLION LOAD SPACING (m)	0.600	1.600	1.460	1.300	1.180	1.120
	0.800	1.460	1.320	1.180	1.080	1.020
	1.000	1.360	1.220	1.080	1.000	0.940
	1.200	1.280	1.160	1.020	0.940	0.880
	1.400	1.200	1.100	0.980	0.900	0.840
	1.600	1.160	1.040	0.940	0.860	0.800
	1.800	1.120	1.000	0.900	0.820	0.760
	2.000	1.080	0.980	0.860	0.800	0.740
	2.200	1.040	0.940	0.840	0.760	0.720
	2.400	1.000	0.920	0.820	0.740	0.700
2.600	0.980	0.900	0.780	0.720	0.680	

SECTION(S):  
G327

DESCRIPTION:  
LIGHT MULLION

DATA:  
MOMENT OF INERTIA - 135014 mm<sup>4</sup>

DEFLECTION MAX:  
15mm

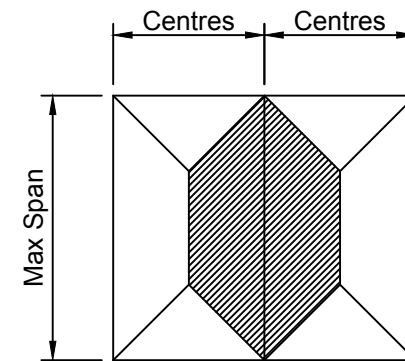
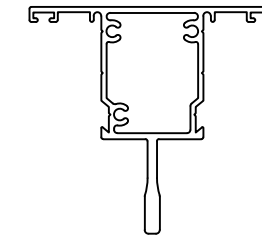

MULLION DATA - Mullion spacing and span calculations are to the current NZS 4211:2008  
Tables shall be used only where no Specific Design wind pressures are specified by the designers. The data provided is given for guidance only and the manufacturer takes no responsibility for incorrect interpretation. It is recommended that a qualified designer be consulted before fabrication.  
SPAN (m) - ULTIMATE (UWP) - SERVICEABILITY (SWP)  
SPAN / DEFLECTION (SPAN / DEF) = RESIDENTIAL 200 min

WIND ZONE :		LOW	MEDIUM	HIGH	VERY HIGH	EXTRA HIGH
SPAN / DEF. :		200	200	200	200	200
MULLION LOAD SPACING (m)	0.600	2.260	2.060	1.820	1.680	1.560
	0.800	2.060	1.860	1.660	1.520	1.420
	1.000	1.900	1.720	1.540	1.400	1.320
	1.200	1.800	1.620	1.440	1.320	1.240
	1.400	1.700	1.540	1.380	1.260	1.180
	1.600	1.620	1.480	1.320	1.200	1.120
	1.800	1.560	1.420	1.260	1.160	1.080
	2.000	1.500	1.380	1.220	1.120	1.040
	2.200	1.460	1.320	1.180	1.080	1.020
	2.400	1.420	1.280	1.140	1.060	0.980
2.600	1.380	1.260	1.120	1.020	0.960	

REV#	DESCRIPTION	DATE
A	G326 Table Updated	10/06/15
B	Tables Updated	24/08/16

## SPAN TABLES

SCALE	NAME	DATE
1:2 @ A3		
DRAWN	T.S	12/2013
CHECKED	M.C	00/2013



DRAWING No.

301.T.01

AWNING WINDOW

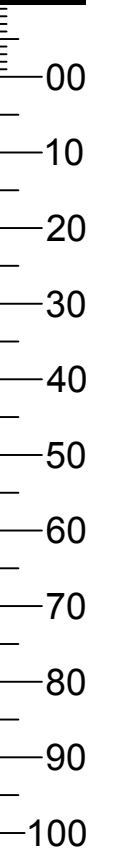

COPYRIGHT © 2011 MCKECHNIE ALUMINIUM SOLUTIONS LIMITED.  
PLEASE CHECK THAT ALL DETAILS ARE UP TO DATE BEFORE  
PROCEEDING. IF IN DOUBT ASK.

SECTION(S):  
X503

DESCRIPTION:  
MEDIUM MULLION

DATA:  
MOMENT OF INERTIA - 404385 mm<sup>4</sup>

DEFLECTION MAX:  
15mm

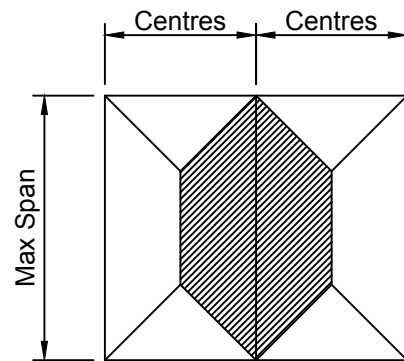
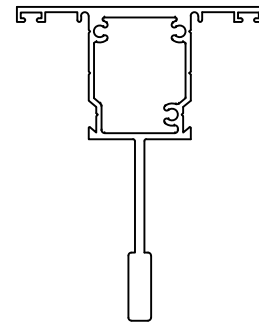

MULLION DATA - Mullion spacing and span calculations are to the current NZS 4211:2008  
Tables shall be used only where no Specific Design wind pressures are specified by the designers. The data provided is given for guidance only and the manufacturer takes no responsibility for incorrect interpretation. It is recommended that a qualified designer be consulted before fabrication.  
SPAN (m) - ULTIMATE (UWP) - SERVICEABILITY (SWP)  
SPAN / DEFLECTION (SPAN / DEF) = RESIDENTIAL 200 min

WIND ZONE :	LOW	MEDIUM	HIGH	VERY HIGH	EXTRA HIGH	
SPAN / DEF. :	200	200	200	200	200	
MULLION LOAD SPACING (m)	0.600	3.200	2.960	2.640	2.420	2.260
	0.800	2.960	2.700	2.380	2.200	2.060
	1.000	2.740	2.500	2.220	2.040	1.900
	1.200	2.580	2.340	2.080	1.920	1.800
	1.400	2.460	2.240	1.980	1.820	1.700
	1.600	2.340	2.140	1.900	1.740	1.640
	1.800	2.260	2.060	1.820	1.680	1.560
	2.000	2.180	1.980	1.760	1.620	1.520
	2.200	2.120	1.920	1.700	1.560	1.460
	2.400	2.060	1.860	1.660	1.520	1.420
2.600	2.000	1.820	1.600	1.480	1.380	

SECTION(S):  
J602 + K538

DESCRIPTION:  
SPLIT MEDIUM MULLION

DATA:  
MOMENT OF INERTIA - 244938 mm<sup>4</sup>

DEFLECTION MAX:  
15mm

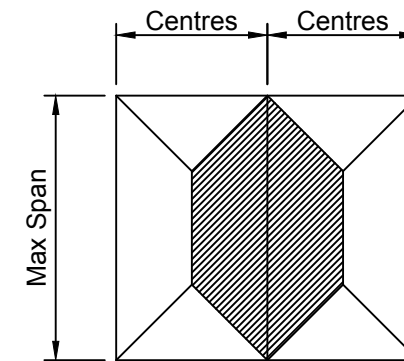
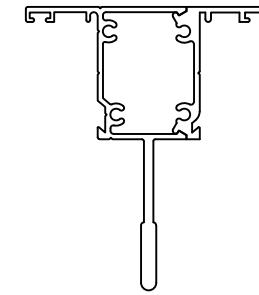

MULLION DATA - Mullion spacing and span calculations are to the current NZS 4211:2008  
Tables shall be used only where no Specific Design wind pressures are specified by the designers. The data provided is given for guidance only and the manufacturer takes no responsibility for incorrect interpretation. It is recommended that a qualified designer be consulted before fabrication.  
SPAN (m) - ULTIMATE (UWP) - SERVICEABILITY (SWP)  
SPAN / DEFLECTION (SPAN / DEF) = RESIDENTIAL 200 min

WIND ZONE :	LOW	MEDIUM	HIGH	VERY HIGH	EXTRA HIGH	
SPAN / DEF. :	200	200	200	200	200	
MULLION LOAD SPACING (m)	0.600	2.760	2.500	2.220	2.040	1.920
	0.800	2.500	2.280	2.020	1.860	1.740
	1.000	2.320	2.120	1.880	1.720	1.620
	1.200	2.180	1.980	1.760	1.620	1.520
	1.400	2.080	1.880	1.680	1.540	1.440
	1.600	1.980	1.800	1.600	1.480	1.380
	1.800	1.900	1.740	1.540	1.420	1.320
	2.000	1.840	1.680	1.480	1.360	1.280
	2.200	1.780	1.620	1.440	1.320	1.240
	2.400	1.740	1.580	1.400	1.280	1.200
2.600	1.680	1.540	1.360	1.240	1.180	

REV#	DESCRIPTION	DATE
A	Tables Updated	24/08/16

## SPAN TABLES

SCALE	1:2 @ A3
NAME	DATE
DRAWN	T.S 12/2013
CHECKED	M.C 00/2013



DRAWING No.  
**301.T.02**

AWNING WINDOW

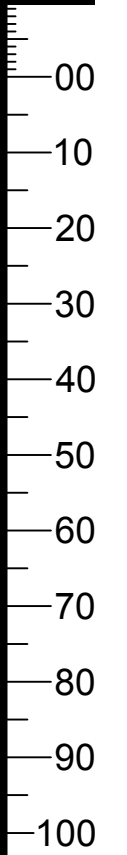

COPYRIGHT © 2011 MCKECHNIE ALUMINIUM SOLUTIONS LIMITED.  
PLEASE CHECK THAT ALL DETAILS ARE UP TO DATE BEFORE  
PROCEEDING. IF IN DOUBT ASK.

SECTION(S):  
36326

DESCRIPTION:  
LIGHT DUTY BOX MULLION

DATA:  
MOMENT OF INERTIA - 115720 mm<sup>4</sup>

DEFLECTION MAX:  
15mm

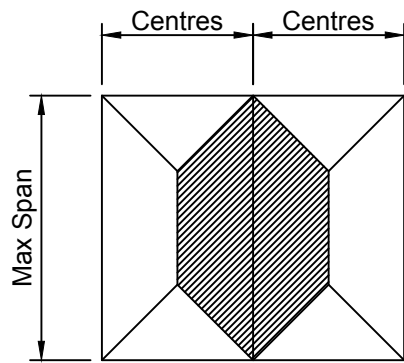
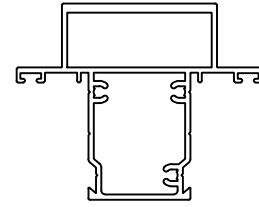

MULLION DATA - Mullion spacing and span calculations are to the current NZS 4211:2008  
Tables shall be used only where no Specific Design wind pressures are specified by the designers. The data provided is given for guidance only and the manufacturer takes no responsibility for incorrect interpretation. It is recommended that a qualified designer be consulted before fabrication.  
SPAN (m) - ULTIMATE (UWP) - SERVICEABILITY (SWP)  
SPAN / DEFLECTION (SPAN / DEF) = RESIDENTIAL 200 min

WIND ZONE :	LOW	MEDIUM	HIGH	VERY HIGH	EXTRA HIGH	
SPAN / DEF. :	200	200	200	200	200	
MULLION LOAD SPACING (m)	0.600	2.140	1.940	1.740	1.580	1.480
	0.800	1.940	1.760	1.580	1.440	1.360
	1.000	1.800	1.640	1.460	1.340	1.260
	1.200	1.700	1.540	1.380	1.260	1.180
	1.400	1.620	1.460	1.300	1.200	1.120
	1.600	1.540	1.400	1.240	1.140	1.080
	1.800	1.480	1.340	1.200	1.100	1.020
	2.000	1.440	1.300	1.160	1.060	1.000
	2.200	1.380	1.260	1.120	1.020	0.960
	2.400	1.340	1.220	1.080	1.000	0.940
2.600	1.320	1.200	1.060	0.980	0.900	

SECTION(S):  
36325

DESCRIPTION:  
MEDIUM DUTY BOX MULLION

DATA:  
MOMENT OF INERTIA - 238248 mm<sup>4</sup>

DEFLECTION MAX:  
15mm

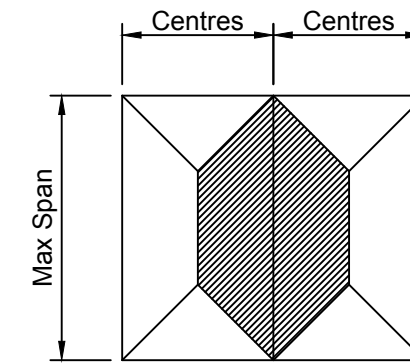
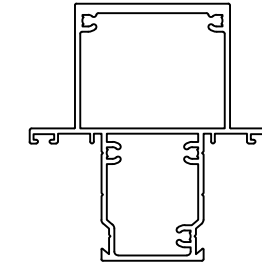

MULLION DATA - Mullion spacing and span calculations are to the current NZS 4211:2008  
Tables shall be used only where no Specific Design wind pressures are specified by the designers. The data provided is given for guidance only and the manufacturer takes no responsibility for incorrect interpretation. It is recommended that a qualified designer be consulted before fabrication.  
SPAN (m) - ULTIMATE (UWP) - SERVICEABILITY (SWP)  
SPAN / DEFLECTION (SPAN / DEF) = RESIDENTIAL 200 min

WIND ZONE :	LOW	MEDIUM	HIGH	VERY HIGH	EXTRA HIGH	
SPAN / DEF. :	200	200	200	200	200	
MULLION LOAD SPACING (m)	0.600	2.740	2.480	2.200	2.020	1.900
	0.800	2.480	2.260	2.000	1.840	1.720
	1.000	2.300	2.100	1.860	1.700	1.600
	1.200	2.160	1.960	1.740	1.600	1.500
	1.400	2.060	1.860	1.660	1.520	1.420
	1.600	1.960	1.780	1.580	1.460	1.360
	1.800	1.900	1.720	1.520	1.400	1.320
	2.000	1.820	1.660	1.480	1.360	1.260
	2.200	1.760	1.600	1.420	1.300	1.220
	2.400	1.720	1.560	1.380	1.280	1.200
2.600	1.680	1.520	1.340	1.240	1.160	

REV#	DESCRIPTION	DATE
A	Page Renumbered	19-03-15
B	Tables Updated	24/08/16

## SPAN TABLES

SCALE	NAME	DATE
1:2 @ A3		
DRAWN	J.M	12/2014
CHECKED	M.C	00/2013



DRAWING No.  
301.T.02.01

AWNING WINDOW

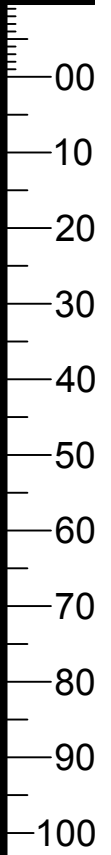

COPYRIGHT © 2011 MCKECHNIE ALUMINIUM SOLUTIONS LIMITED.  
PLEASE CHECK THAT ALL DETAILS ARE UP TO DATE BEFORE  
PROCEEDING. IF IN DOUBT ASK.

SECTION(S):  
36324

DESCRIPTION:  
HEAVY DUTY BOX MULLION

DATA:  
MOMENT OF INERTIA - 654683 mm<sup>4</sup>

DEFLECTION MAX:  
15mm

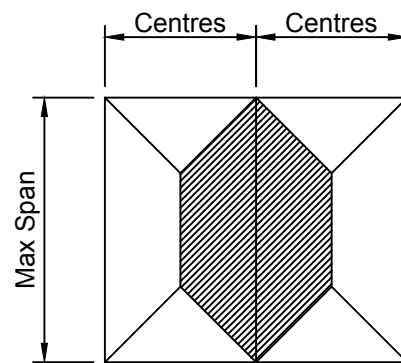
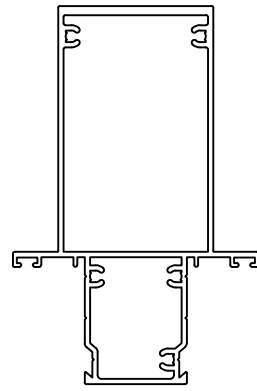

MULLION DATA - Mullion spacing and span calculations are to the current NZS 4211:2008  
Tables shall be used only where no Specific Design wind pressures are specified by the designers. The data provided is given for guidance only and the manufacturer takes no responsibility for incorrect interpretation. It is recommended that a qualified designer be consulted before fabrication.  
SPAN (m) - ULTIMATE (UWP) - SERVICEABILITY (SWP)  
SPAN / DEFLECTION (SPAN / DEF) = RESIDENTIAL 200 min

WIND ZONE :	LOW	MEDIUM	HIGH	VERY HIGH	EXTRA HIGH
SPAN / DEF. :	200	200	200	200	200
MULLION LOAD SPACING (m)	0.600	3.600	3.360	3.060	2.660
	0.800	3.360	3.120	2.800	2.420
	1.000	3.160	2.940	2.600	2.240
	1.200	3.020	2.760	2.460	2.120
	1.400	2.880	2.620	2.320	2.000
	1.600	2.760	2.500	2.220	1.920
	1.800	2.660	2.400	2.140	1.840
	2.000	2.560	2.320	2.060	1.780
	2.200	2.480	2.260	2.000	1.720
	2.400	2.400	2.180	1.940	1.680
2.600	2.340	2.140	1.900	1.620	

SECTION(S):  
30144

DESCRIPTION:  
HEAVY MULLION

DATA:  
MOMENT OF INERTIA - 1107582 mm<sup>4</sup>

DEFLECTION MAX:  
15mm

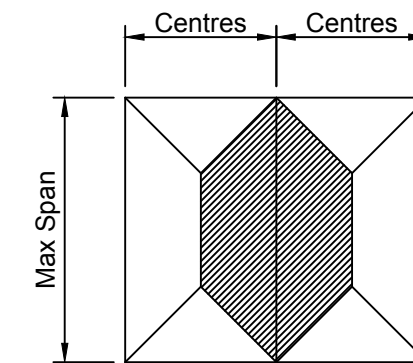
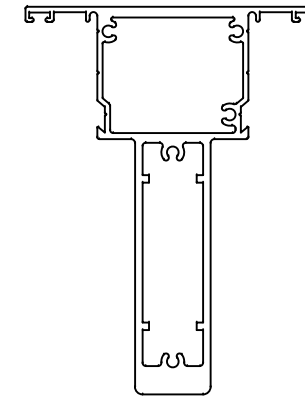

MULLION DATA - Mullion spacing and span calculations are to the current NZS 4211:2008  
Tables shall be used only where no Specific Design wind pressures are specified by the designers. The data provided is given for guidance only and the manufacturer takes no responsibility for incorrect interpretation. It is recommended that a qualified designer be consulted before fabrication.  
SPAN (m) - ULTIMATE (UWP) - SERVICEABILITY (SWP)  
SPAN / DEFLECTION (SPAN / DEF) = RESIDENTIAL 200 min

WIND ZONE :	LOW	MEDIUM	HIGH	VERY HIGH	EXTRA HIGH
SPAN / DEF. :	200	200	200	200	200
MULLION LOAD SPACING (m)	0.600	4.100	3.820	3.500	3.120
	0.800	3.820	3.560	3.260	2.880
	1.000	3.620	3.360	3.080	2.680
	1.200	3.460	3.220	2.920	2.520
	1.400	3.320	3.100	2.780	2.400
	1.600	3.220	2.980	2.660	2.280
	1.800	3.120	2.880	2.560	2.200
	2.000	3.040	2.780	2.460	2.120
	2.200	2.960	2.680	2.380	2.060
	2.400	2.880	2.600	2.320	2.000
2.600	2.800	2.540	2.260	1.940	

REV#	DESCRIPTION	DATE

SPAN TABLES

SCALE	1:2 @ A3
NAME	
DRAWN	J.M 12/2014
CHECKED	M.C 00/2013



DRAWING No. 301.T.02.02

AWNING WINDOW

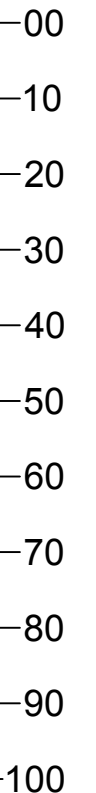

COPYRIGHT © 2011 MCKECHNIE ALUMINIUM SOLUTIONS LIMITED. PLEASE CHECK THAT ALL DETAILS ARE UP TO DATE BEFORE PROCEEDING. IF IN DOUBT ASK.

SECTION(S):  
36000 + 35338 (TRIMMED) + 36000

DESCRIPTION:  
WINDOW FRAME + SMALL TEE COUPLER  
+ WINDOW FRAME

DATA:  
MOMENT OF INERTIA - 759090 mm<sup>4</sup>

DEFLECTION MAX:  
15mm

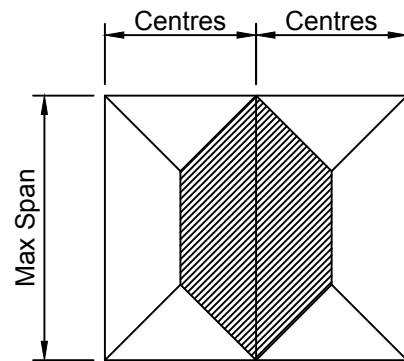
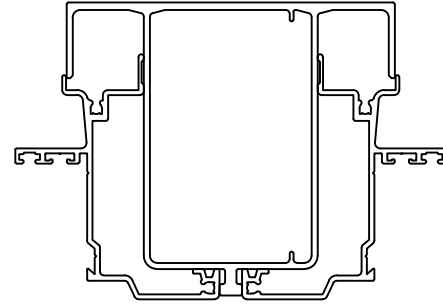

MULLION DATA - Mullion spacing and span calculations are to the current NZS 4211:2008  
Tables shall be used only where no Specific Design wind pressures are specified by the designers. The data provided is given for guidance only and the manufacturer takes no responsibility for incorrect interpretation. It is recommended that a qualified designer be consulted before fabrication.  
SPAN (m) - ULTIMATE (UWP) - SERVICEABILITY (SWP)  
SPAN / DEFLECTION (SPAN / DEF) = RESIDENTIAL 200 min

WIND ZONE :	LOW	MEDIUM	HIGH	VERY HIGH	EXTRA HIGH	
SPAN / DEF. :	200	200	200	200	200	
MULLION LOAD SPACING (m)	0.600	3.740	3.480	3.180	2.980	2.800
	0.800	3.480	3.240	2.940	2.700	2.540
	1.000	3.280	3.060	2.740	2.520	2.360
	1.200	3.140	2.900	2.580	2.360	2.220
	1.400	3.020	2.760	2.440	2.240	2.100
	1.600	2.900	2.640	2.340	2.140	2.020
	1.800	2.780	2.540	2.240	2.060	1.940
	2.000	2.700	2.440	2.180	2.000	1.860
	2.200	2.600	2.360	2.100	1.940	1.820
	2.400	2.540	2.300	2.040	1.880	1.760
2.600	2.460	2.240	1.980	1.820	1.720	

SECTION(S):  
J603

DESCRIPTION:  
90° Corner Mullion

DATA:  
MOMENT OF INERTIA - 70270 mm<sup>4</sup>

DEFLECTION MAX:  
15mm

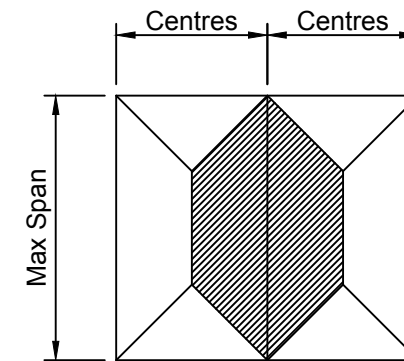
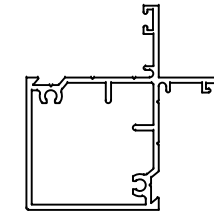

MULLION DATA - Mullion spacing and span calculations are to the current NZS 4211:2008  
Tables shall be used only where no Specific Design wind pressures are specified by the designers. The data provided is given for guidance only and the manufacturer takes no responsibility for incorrect interpretation. It is recommended that a qualified designer be consulted before fabrication.  
SPAN (m) - ULTIMATE (UWP) - SERVICEABILITY (SWP)  
SPAN / DEFLECTION (SPAN / DEF) = RESIDENTIAL 200 min

WIND ZONE :	LOW	MEDIUM	HIGH	VERY HIGH	EXTRA HIGH	
SPAN / DEF. :	200	200	200	200	200	
MULLION LOAD SPACING (m)	0.600	1.820	1.640	1.460	1.340	1.260
	0.800	1.640	1.500	1.320	1.220	1.140
	1.000	1.520	1.380	1.240	1.140	1.060
	1.200	1.440	1.300	1.160	1.060	1.000
	1.400	1.360	1.240	1.100	1.020	0.940
	1.600	1.300	1.180	1.060	0.960	0.900
	1.800	1.260	1.140	1.020	0.920	0.880
	2.000	1.220	1.100	0.980	0.900	0.840
	2.200	1.180	1.060	0.940	0.860	0.820
	2.400	1.140	1.040	0.920	0.840	0.800
2.600	1.100	1.000	0.900	0.820	0.760	

REV#	DESCRIPTION	DATE

SPAN TABLES

SCALE	1:2 @ A3
NAME	
DRAWN	J.M 12/2014
CHECKED	M.C 00/2013



DRAWING No. 301.T.02.03

AWNING WINDOW

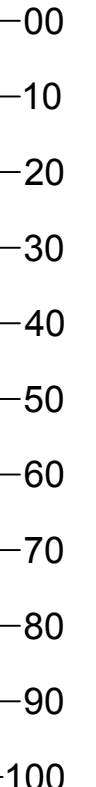

COPYRIGHT © 2011 MCKECHNIE ALUMINIUM SOLUTIONS LIMITED. PLEASE CHECK THAT ALL DETAILS ARE UP TO DATE BEFORE PROCEEDING. IF IN DOUBT ASK.

SECTION(S):  
J601

DESCRIPTION:  
135° Corner Mullion

DATA:  
MOMENT OF INERTIA - 78075 mm<sup>4</sup>

DEFLECTION MAX:  
15mm

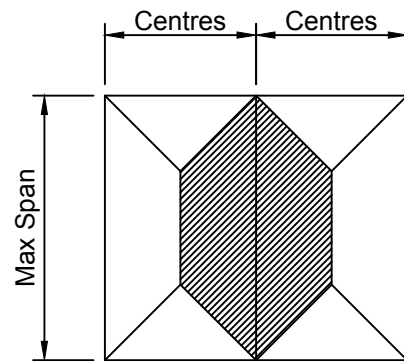
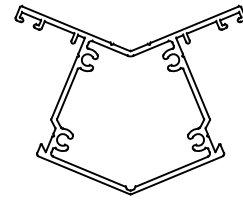

MULLION DATA - Mullion spacing and span calculations are to the current NZS 4211:2008  
Tables shall be used only where no Specific Design wind pressures are specified by the designers. The data provided is given for guidance only and the manufacturer takes no responsibility for incorrect interpretation. It is recommended that a qualified designer be consulted before fabrication.  
SPAN (m) - ULTIMATE (UWP) - SERVICEABILITY (SWP)  
SPAN / DEFLECTION (SPAN / DEF) = RESIDENTIAL 200 min

WIND ZONE :	LOW	MEDIUM	HIGH	VERY HIGH	EXTRA HIGH	
SPAN / DEF. :	200	200	200	200	200	
MULLION LOAD SPACING (m)	0.600	1.880	1.700	1.520	1.400	1.300
	0.800	1.700	1.560	1.380	1.260	1.180
	1.000	1.580	1.440	1.280	1.180	1.100
	1.200	1.500	1.360	1.200	1.100	1.040
	1.400	1.420	1.280	1.140	1.040	0.980
	1.600	1.360	1.220	1.100	1.000	0.940
	1.800	1.300	1.180	1.040	0.960	0.900
	2.000	1.260	1.140	1.020	0.920	0.880
	2.200	1.220	1.100	0.980	0.900	0.840
	2.400	1.180	1.080	0.960	0.880	0.820
2.600	1.140	1.040	0.920	0.860	0.800	

AWNING WINDOW

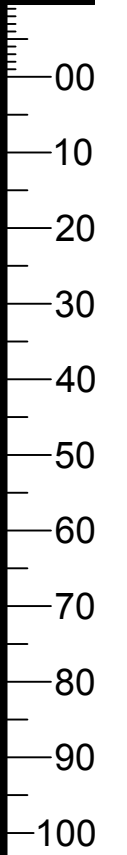

REV#	DESCRIPTION	DATE

SPAN TABLES

SCALE	1:2 @ A3	
NAME		DATE
DRAWN	J.M	12/2014
CHECKED	M.C	00/2013



DRAWING No.

301.T.02.04

COPYRIGHT © 2011 MCKECHNIE ALUMINIUM SOLUTIONS LIMITED.  
PLEASE CHECK THAT ALL DETAILS ARE UP TO DATE BEFORE  
PROCEEDING. IF IN DOUBT ASK  
AS ORIGINAL SIZE.

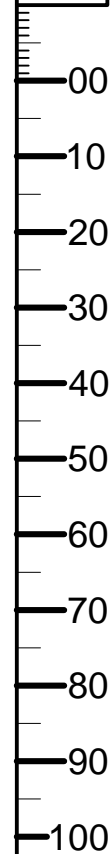

# 313

## Bi Fold

# Span Charts

REV#	DESCRIPTION	DATE
-	-	00/2013
-	-	00/2013
-	-	00/2013
-	-	00/00/2013

SPAN CHART

SCALE	NTS	
	NAME	DATE
DRAWN	ADM	05/10/17
CHECKED		



DRAWING No. 300 SERIES SP



SECTION(S):  
35822 + 35822

DESCRIPTION:  
BIFOLD NARROW STILES

DATA:  
MOMENT OF INERTIA - 223078 mm<sup>4</sup>

DEFLECTION MAX:  
15mm

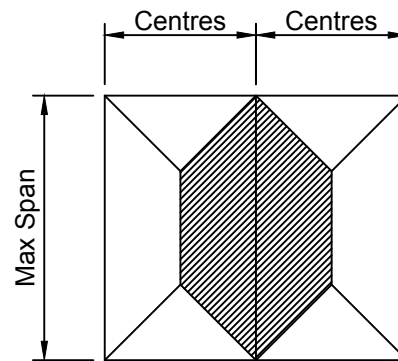
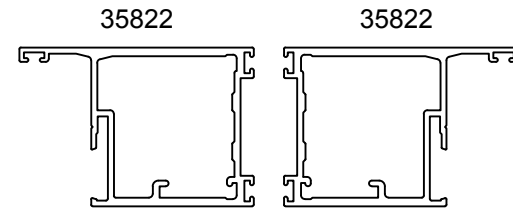

SECTION(S):  
35823 + 35823

DESCRIPTION:  
BIFOLD WIDE STILES

DATA:  
MOMENT OF INERTIA - 423013 mm<sup>4</sup>

DEFLECTION MAX:  
15mm

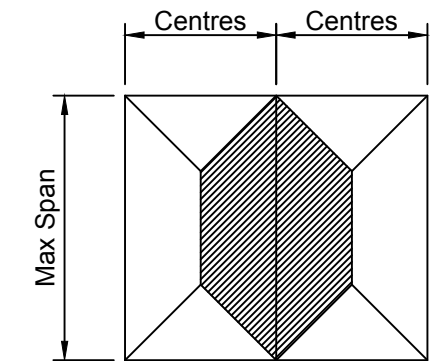
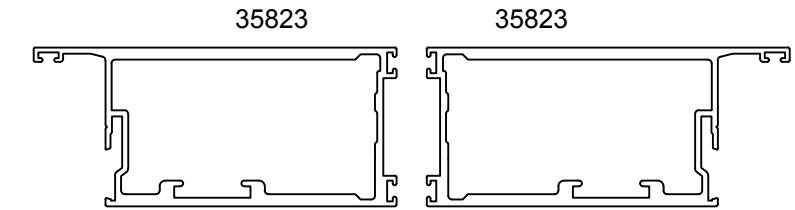

MULLION DATA - Mullion spacing and span calculations are to the current NZS 4211:2008  
Tables shall be used only where no Specific Design wind pressures are specified by the designers. The data provided is given for guidance only and the manufacturer takes no responsibility for incorrect interpretation. It is recommended that a qualified designer be consulted before fabrication.  
SPAN (m) - ULTIMATE (UWP) - SERVICEABILITY (SWP)  
SPAN / DEFLECTION (SPAN / DEF) = RESIDENTIAL 200 min

MULLION DATA - Mullion spacing and span calculations are to the current NZS 4211:2008  
Tables shall be used only where no Specific Design wind pressures are specified by the designers. The data provided is given for guidance only and the manufacturer takes no responsibility for incorrect interpretation. It is recommended that a qualified designer be consulted before fabrication.  
SPAN (m) - ULTIMATE (UWP) - SERVICEABILITY (SWP)  
SPAN / DEFLECTION (SPAN / DEF) = RESIDENTIAL 200 min

WIND ZONE :	LOW	MEDIUM	HIGH	VERY HIGH	EXTRA HIGH	
SPAN / DEF. :	200	200	200	200	200	
MULLION LOAD SPACING (m)	0.600	2.680	2.420	2.160	1.980	1.860
	0.700	2.540	2.300	2.040	1.880	1.760
	0.800	2.420	2.200	1.960	1.800	1.680
	0.900	2.340	2.120	1.880	1.720	1.620
	1.000	2.260	2.040	1.820	1.660	1.560
	1.100	2.180	1.980	1.760	1.620	1.520
	1.200	2.120	1.920	1.700	1.560	1.480
	1.300	2.060	1.880	1.660	1.520	1.440
	1.400	2.020	1.820	1.620	1.500	1.400
	1.500	1.960	1.780	1.580	1.460	1.360
1.600	1.920	1.740	1.560	1.420	1.340	

WIND ZONE :	LOW	MEDIUM	HIGH	VERY HIGH	EXTRA HIGH	
SPAN / DEF. :	200	200	200	200	200	
MULLION LOAD SPACING (m)	0.600	3.220	3.000	2.680	2.460	2.300
	0.700	3.100	2.860	2.540	2.320	2.180
	0.800	3.000	2.740	2.420	2.220	2.080
	0.900	2.900	2.620	2.340	2.140	2.000
	1.000	2.800	2.540	2.260	2.060	1.940
	1.100	2.700	2.460	2.180	2.000	1.880
	1.200	2.620	2.380	2.120	1.940	1.820
	1.300	2.560	2.320	2.060	1.900	1.780
	1.400	2.500	2.260	2.020	1.840	1.740
	1.500	2.440	2.220	1.960	1.800	1.700
1.600	2.380	2.160	1.920	1.760	1.660	

REV#	DESCRIPTION	DATE

## Residential- Span Charts

SCALE	1:2 @ A3
NAME	DATE
DRAWN	T.S 12/2013
CHECKED	M.C 07/2014



DRAWING No.

313.3.1

Residential Bifold Door

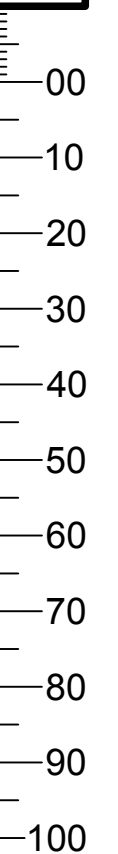

COPYRIGHT © 2011 MCKECHNIE ALUMINIUM SOLUTIONS LIMITED.  
PLEASE CHECK THAT ALL DETAILS ARE UP TO DATE BEFORE  
PROCEEDING. IF IN DOUBT ASK.

SECTION(S):  
35820 + 35821

DESCRIPTION:  
FRENCH DOOR STILES

DATA:  
MOMENT OF INERTIA - 366015 mm<sup>4</sup>

DEFLECTION MAX:  
15mm

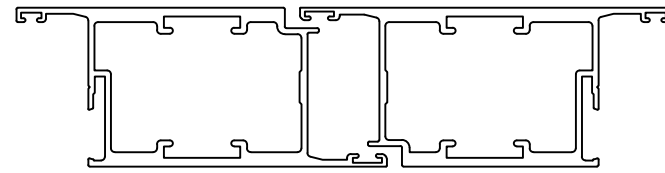

SECTION(S):  
36639 + 36640

DESCRIPTION:  
BIFOLD 3-2-1 STILES

DATA:  
MOMENT OF INERTIA - 289237 mm<sup>4</sup>

DEFLECTION MAX:  
15mm

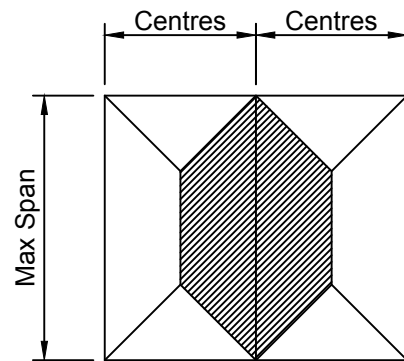
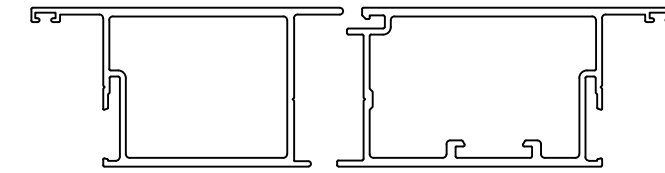

MULLION DATA - Mullion spacing and span calculations are to the current NZS 4211:2008  
Tables shall be used only where no Specific Design wind pressures are specified by the designers. The data provided is given for guidance only and the manufacturer takes no responsibility for incorrect interpretation. It is recommended that a qualified designer be consulted before fabrication.  
SPAN (m) - ULTIMATE (UWP) - SERVICEABILITY (SWP)  
SPAN / DEFLECTION (SPAN / DEF) = RESIDENTIAL 200 min

MULLION DATA - Mullion spacing and span calculations are to the current NZS 4211:2008  
Tables shall be used only where no Specific Design wind pressures are specified by the designers. The data provided is given for guidance only and the manufacturer takes no responsibility for incorrect interpretation. It is recommended that a qualified designer be consulted before fabrication.  
SPAN (m) - ULTIMATE (UWP) - SERVICEABILITY (SWP)  
SPAN / DEFLECTION (SPAN / DEF) = RESIDENTIAL 200 min

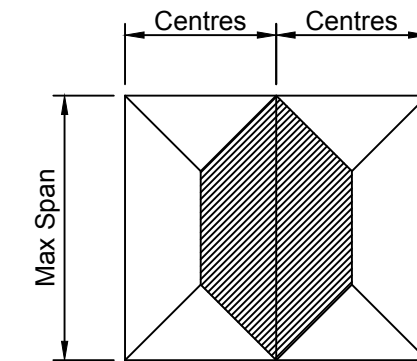

WIND ZONE :	LOW	MEDIUM	HIGH	VERY HIGH	EXTRA HIGH	
SPAN / DEF. :	200	200	200	200	200	
MULLION LOAD SPACING (m)	0.600	3.120	2.860	2.540	2.340	2.200
	0.700	3.000	2.720	2.420	2.220	2.080
	0.800	2.860	2.600	2.320	2.120	2.000
	0.900	2.760	2.500	2.220	2.040	1.920
	1.000	2.660	2.420	2.140	1.960	1.840
	1.100	2.580	2.340	2.080	1.900	1.780
	1.200	2.500	2.280	2.020	1.860	1.740
	1.300	2.440	2.220	1.960	1.800	1.700
	1.400	2.380	2.160	1.920	1.760	1.640
	1.500	2.320	2.100	1.880	1.720	1.620
1.600	2.280	2.060	1.840	1.680	1.580	

WIND ZONE :	LOW	MEDIUM	HIGH	VERY HIGH	EXTRA HIGH	
SPAN / DEF. :	200	200	200	200	200	
MULLION LOAD SPACING (m)	0.600	2.920	2.640	2.360	2.160	2.020
	0.700	2.760	2.520	2.240	2.060	1.920
	0.800	2.640	2.400	2.140	1.960	1.840
	0.900	2.540	2.320	2.060	1.880	1.760
	1.000	2.460	2.240	1.980	1.820	1.700
	1.100	2.380	2.160	1.920	1.760	1.660
	1.200	2.320	2.100	1.860	1.720	1.600
	1.300	2.260	2.040	1.820	1.660	1.560
	1.400	2.200	2.000	1.780	1.620	1.520
	1.500	2.140	1.940	1.720	1.560	1.480
1.600	2.100	1.900	1.700	1.560	1.460	

REV#	DESCRIPTION	DATE

## Residential- Span Charts

SCALE	1:2 @ A3
NAME	DATE
DRAWN	T.S 12/2013
CHECKED	M.C 07/2014



DRAWING No.

313.3.2

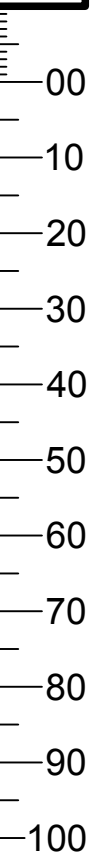

SECTION(S):  
35822 + 35970

DESCRIPTION:  
BIFOLD FOLD BACK

DATA:  
MOMENT OF INERTIA - 190055 mm<sup>4</sup>

DEFLECTION MAX:  
15mm

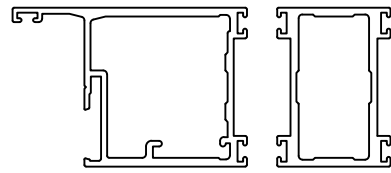

SECTION(S):  
35822 + 37128 + 36640

DESCRIPTION:  
BIFOLD 3-2-1 FOLD BACK

DATA:  
MOMENT OF INERTIA - 338958 mm<sup>4</sup>

DEFLECTION MAX:  
15mm

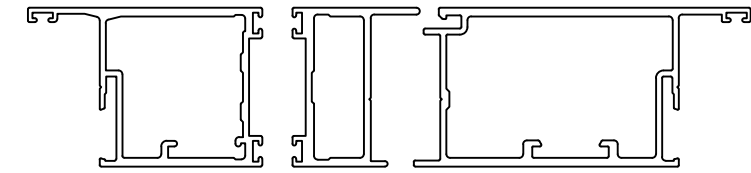

MULLION DATA - Mullion spacing and span calculations are to the current NZS 4211:2008  
Tables shall be used only where no Specific Design wind pressures are specified by the designers. The data provided is given for guidance only and the manufacturer takes no responsibility for incorrect interpretation. It is recommended that a qualified designer be consulted before fabrication.  
SPAN (m) - ULTIMATE (UWP) - SERVICEABILITY (SWP)  
SPAN / DEFLECTION (SPAN / DEF) = RESIDENTIAL 200 min

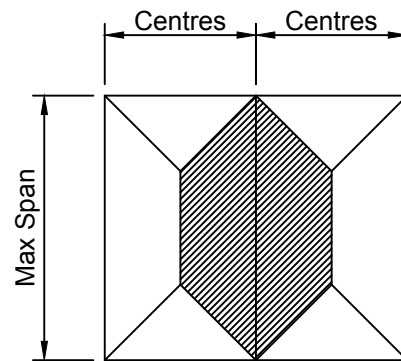

MULLION DATA - Mullion spacing and span calculations are to the current NZS 4211:2008  
Tables shall be used only where no Specific Design wind pressures are specified by the designers. The data provided is given for guidance only and the manufacturer takes no responsibility for incorrect interpretation. It is recommended that a qualified designer be consulted before fabrication.  
SPAN (m) - ULTIMATE (UWP) - SERVICEABILITY (SWP)  
SPAN / DEFLECTION (SPAN / DEF) = RESIDENTIAL 200 min

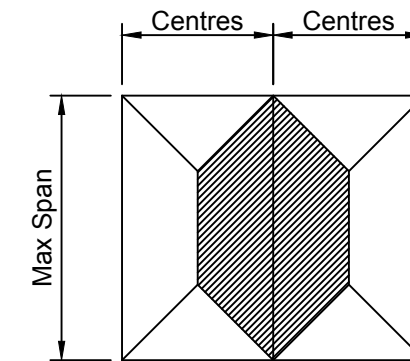

WIND ZONE :		LOW	MEDIUM	HIGH	VERY HIGH	EXTRA HIGH
SPAN / DEF. :		200	200	200	200	200
MULLION LOAD SPACING (m)	0.600	2.000	1.820	1.620	1.480	1.400
	0.700	1.900	1.740	1.540	1.420	1.320
	0.800	1.820	1.660	1.480	1.360	1.260
	0.900	1.760	1.600	1.420	1.300	1.220
	1.000	1.700	1.540	1.360	1.260	1.180
	1.100	1.640	1.480	1.320	1.220	1.140
	1.200	1.600	1.440	1.280	1.180	1.100
	1.300	1.560	1.400	1.240	1.140	1.080
	1.400	1.520	1.380	1.220	1.120	1.040
	1.500	1.480	1.340	1.200	1.100	1.020
1.600	1.440	1.320	1.160	1.060	1.000	

WIND ZONE :		LOW	MEDIUM	HIGH	VERY HIGH	EXTRA HIGH
SPAN / DEF. :		200	200	200	200	200
MULLION LOAD SPACING (m)	0.600	3.060	2.800	2.480	2.280	2.140
	0.700	2.920	2.660	2.360	2.160	2.020
	0.800	2.800	2.540	2.260	2.060	1.940
	0.900	2.680	2.440	2.160	1.980	1.860
	1.000	2.600	2.360	2.080	1.920	1.800
	1.100	2.520	2.280	2.020	1.860	1.740
	1.200	2.440	2.220	1.960	1.800	1.700
	1.300	2.380	2.160	1.920	1.780	1.640
	1.400	2.320	2.100	1.860	1.720	1.600
	1.500	2.260	2.060	1.820	1.680	1.580
1.600	2.220	2.020	1.780	1.640	1.540	

REV#	DESCRIPTION	DATE

## Residential- Span Charts

SCALE	1:1 @ A3
NAME	DATE
DRAWN	T.S 12/2013
CHECKED	M.C 07/2014



DRAWING No.

313.3.3

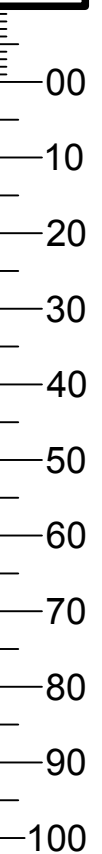

SECTION(S):  
34816 + 35338 + 36000

DESCRIPTION:  
HINGED DOOR + SMALL TEE COUPLER  
+ WINDOW FRAME

DATA:  
MOMENT OF INERTIA - 882064 mm<sup>4</sup>

DEFLECTION MAX:  
15mm

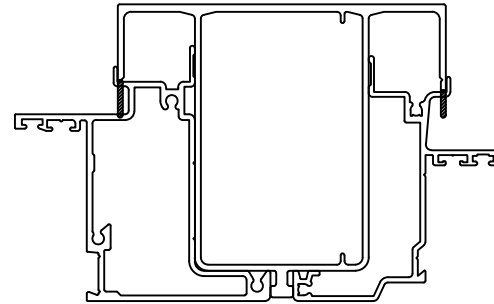

SECTION(S):  
34816 + 36185 + 36000

DESCRIPTION:  
HINGED DOOR + MEDIUM TEE COUPLER  
+ WINDOW FRAME

DATA:  
MOMENT OF INERTIA - 9122645 mm<sup>4</sup>

DEFLECTION MAX:  
15mm

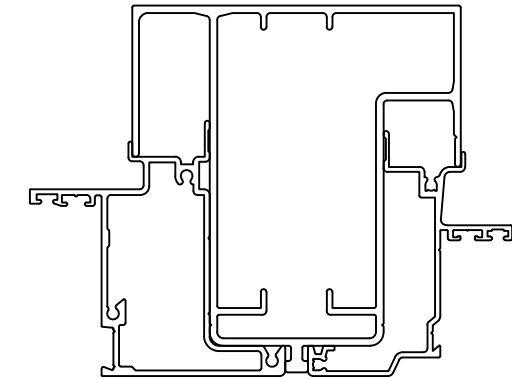

MULLION DATA - Mullion spacing and span calculations are to the current NZS 4211:2008  
Tables shall be used only where no Specific Design wind pressures are specified by the designers. The data provided is given for guidance only and the manufacturer takes no responsibility for incorrect interpretation. It is recommended that a qualified designer be consulted before fabrication.  
SPAN (m) - ULTIMATE (UWP) - SERVICEABILITY (SWP)  
SPAN / DEFLECTION (SPAN / DEF) = RESIDENTIAL 200 min

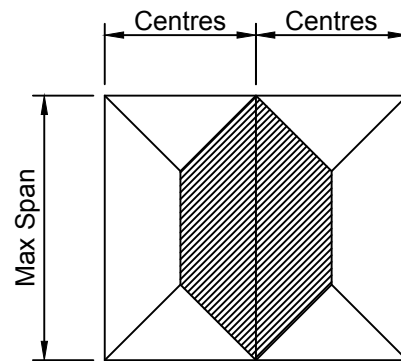

MULLION DATA - Mullion spacing and span calculations are to the current NZS 4211:2008  
Tables shall be used only where no Specific Design wind pressures are specified by the designers. The data provided is given for guidance only and the manufacturer takes no responsibility for incorrect interpretation. It is recommended that a qualified designer be consulted before fabrication.  
SPAN (m) - ULTIMATE (UWP) - SERVICEABILITY (SWP)  
SPAN / DEFLECTION (SPAN / DEF) = RESIDENTIAL 200 min

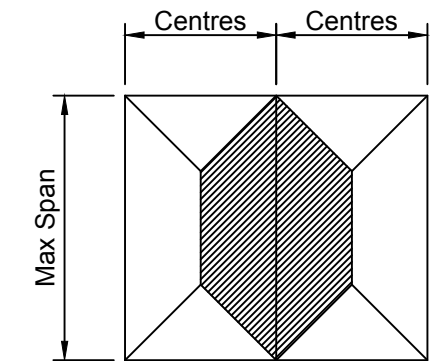

WIND ZONE :	LOW	MEDIUM	HIGH	VERY HIGH	EXTRA HIGH
SPAN / DEF. :	200	200	200	200	200
MULLION LOAD SPACING (m)	0.600	3.880	3.620	3.300	3.100
	0.800	3.620	3.360	3.080	2.840
	1.000	3.420	3.180	2.880	2.640
	1.200	3.260	3.040	2.700	2.480
	1.400	3.140	2.900	2.580	2.360
	1.600	3.040	2.760	2.460	2.220
	1.800	2.940	2.660	2.360	2.120
	2.000	2.840	2.580	2.280	2.040
	2.200	2.740	2.480	2.220	1.960
	2.400	2.660	2.420	2.140	1.900
2.600	2.600	2.360	2.100	1.840	
				1.920	1.800

WIND ZONE :	LOW	MEDIUM	HIGH	VERY HIGH	EXTRA HIGH
SPAN / DEF. :	200	200	200	200	200
MULLION LOAD SPACING (m)	0.600	6.960	6.480	5.940	5.560
	0.800	6.480	6.040	5.520	5.180
	1.000	6.140	5.700	5.220	4.900
	1.200	5.860	5.440	4.980	4.680
	1.400	5.640	5.240	4.800	4.500
	1.600	5.440	5.080	4.640	4.360
	1.800	5.300	4.920	4.500	4.220
	2.000	5.160	4.800	4.380	4.120
	2.200	5.040	4.680	4.280	4.020
	2.400	4.920	4.580	4.200	3.940
2.600	4.820	4.500	4.100	3.860	
				3.680	

REV#	DESCRIPTION	DATE

## Residential- Span Charts

SCALE	1:1 @ A3
NAME	DATE
DRAWN	T.S 12/2013
CHECKED	M.C 07/2014



DRAWING No.

313.3.4

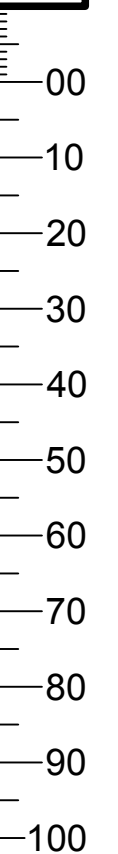

SECTION(S):  
36687

DESCRIPTION:  
TRANSOM / MULLION

DATA:  
MOMENT OF INERTIA - 1332604 mm<sup>4</sup>

DEFLECTION MAX:  
15mm

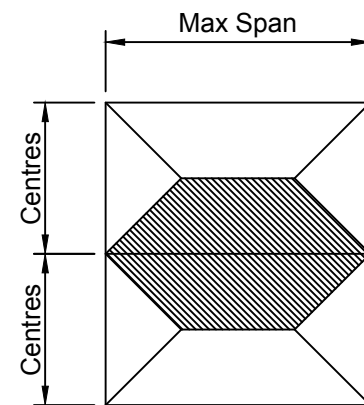
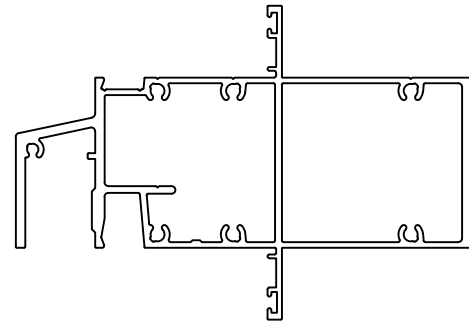

MULLION DATA - Mullion spacing and span calculations are to the current NZS 4211:2008  
Tables shall be used only where no Specific Design wind pressures are specified by the designers. The data provided is given for guidance only and the manufacturer takes no responsibility for incorrect interpretation. It is recommended that a qualified designer be consulted before fabrication.  
SPAN (m) - ULTIMATE (UWP) - SERVICEABILITY (SWP)  
SPAN / DEFLECTION (SPAN / DEF) = RESIDENTIAL 200 min

WIND ZONE :		LOW	MEDIUM	HIGH	VERY HIGH	EXTRA HIGH
SPAN / DEF. :		200	200	200	200	200
MULLION LOAD SPACING (m)	0.600	4.300	4.000	3.660	3.440	3.280
	0.800	4.000	3.720	3.400	3.200	3.040
	1.000	3.780	3.520	3.220	3.020	2.840
	1.200	3.620	3.360	3.080	2.860	2.680
	1.400	3.480	3.240	2.960	2.720	2.540
	1.600	3.360	3.140	2.820	2.600	2.440
	1.800	3.260	3.040	2.720	2.500	2.340
	2.000	3.180	2.960	2.620	2.400	2.260
	2.200	3.100	2.860	2.540	2.340	2.180
	2.400	3.040	2.780	2.460	2.260	2.120
2.600	2.980	2.700	2.400	2.200	2.060	

SECTION(S):  
36000 + 36185 + 34818

DESCRIPTION:  
HEAD FRAME + MEDIUM TEE COUPLER  
+ WINDOW FRAME

DATA:  
MOMENT OF INERTIA - 2032040 mm<sup>4</sup>

DEFLECTION MAX:  
15mm

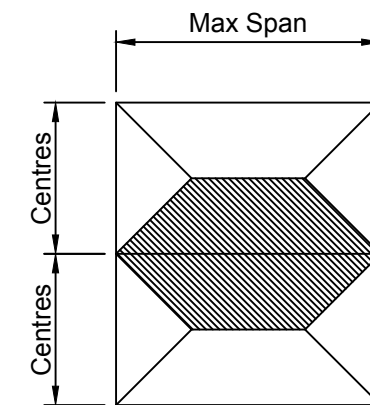
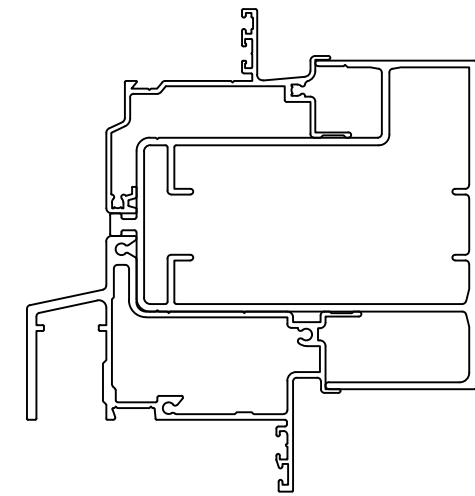

MULLION DATA - Mullion spacing and span calculations are to the current NZS 4211:2008  
Tables shall be used only where no Specific Design wind pressures are specified by the designers. The data provided is given for guidance only and the manufacturer takes no responsibility for incorrect interpretation. It is recommended that a qualified designer be consulted before fabrication.  
SPAN (m) - ULTIMATE (UWP) - SERVICEABILITY (SWP)  
SPAN / DEFLECTION (SPAN / DEF) = RESIDENTIAL 200 min

WIND ZONE :		LOW	MEDIUM	HIGH	VERY HIGH	EXTRA HIGH
SPAN / DEF. :		200	200	200	200	200
MULLION LOAD SPACING (m)	0.600	4.780	4.460	4.080	3.820	3.640
	0.800	4.460	4.140	3.780	3.560	3.380
	1.000	4.200	3.920	3.580	3.360	3.200
	1.200	4.020	3.740	3.420	3.220	3.060
	1.400	3.860	3.600	3.300	3.080	2.920
	1.600	3.740	3.480	3.180	2.980	2.800
	1.800	3.640	3.380	3.100	2.880	2.700
	2.000	3.540	3.300	3.020	2.780	2.600
	2.200	3.460	3.220	2.920	2.680	2.520
	2.400	3.380	3.140	2.840	2.600	2.440
2.600	3.320	3.080	2.760	2.540	2.380	

REV#	DESCRIPTION	DATE

## Residential- Span Charts

SCALE	1:1 @ A3
NAME	DATE
DRAWN	T.S 12/2013
CHECKED	M.C 07/2014



DRAWING No.

313.3.5

Residential Bifold Door

00  
10  
20  
30  
40  
50  
60  
70  
80  
90  
100

COPYRIGHT © 2011 MCKECHNIE ALUMINIUM SOLUTIONS LIMITED.  
PLEASE CHECK THAT ALL DETAILS ARE UP TO DATE BEFORE  
PROCEEDING. IF IN DOUBT ASK.

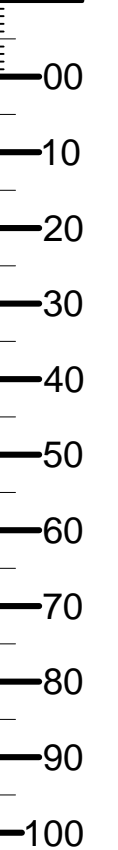

# 309

# Hinged Doors Span Charts

REV#	DESCRIPTION	DATE
-	-	00/2013
-	-	00/2013
-	-	00/2013
-	-	00/00/2013

SPAN CHART

SCALE	NTS	
DRAWN	ADM	05/10/17
CHECKED		



DRAWING No. 300 SERIES SP

SECTION(S):  
34820 + 35819

DESCRIPTION:  
HINGED DOOR MULLION & STANDARD STILE

DATA:  
MOMENT OF INERTIA - 283301.18 mm<sup>4</sup>

DEFLECTION MAX.:  
15mm

1:2 SCALE

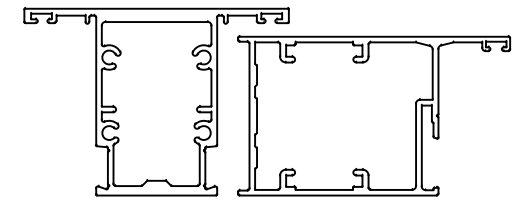

MULLION DATA - Mullion spacing and span calculations are to the current NZS 4211:2008  
Tables shall be used only where no Specific Design wind pressures are specified by the designers. The data provided is given for guidance only and the manufacturer takes no responsibility for incorrect interpretation. It is recommended that a qualified designer be consulted before fabrication.  
SPAN (m) - ULTIMATE (UWP) - SERVICEABILITY (SWP)  
SPAN / DEFLECTION (SPAN / DEF) = RESIDENTIAL 200 min, COMMERCIAL 250 min.

WIND ZONE:	LOW	720 Pa (UWP)		MEDIUM 960 Pa (UWP)		HIGH	1360 Pa (UWP)		VERY HIGH	1760 Pa (UWP)		EXTRA HIGH	2130 Pa (UWP)			
		250 Pa (SWP)	400 Pa (SWP)	200 Pa (SWP)	250 Pa (SWP)		250 Pa (SWP)	400 Pa (SWP)		250 Pa (SWP)	400 Pa (SWP)		200 Pa (SWP)	250 Pa (SWP)	400 Pa (SWP)	
MULLION LOAD SPACING (m)	0.600	2.900	2.600	2.300	2.620	2.440	2.080	2.340	2.160	1.860	2.140	2.000	1.700	2.020	1.860	1.600
	0.800	2.620	2.440	2.080	2.380	2.220	1.900	2.120	1.960	1.680	1.940	1.800	1.640	1.820	1.700	1.440
	1.000	2.440	2.260	1.940	2.220	2.060	1.760	1.960	1.820	1.560	1.800	1.680	1.440	1.700	1.580	1.340
	1.200	2.300	2.140	1.820	2.080	1.940	1.660	1.860	1.720	1.460	1.700	1.580	1.340	1.600	1.480	1.250
	1.400	2.180	2.020	1.720	1.980	1.840	1.560	1.760	1.640	1.400	1.620	1.500	1.280	1.520	1.400	1.200
	1.600	2.080	1.940	1.660	1.900	1.760	1.500	1.680	1.568	1.340	1.540	1.440	1.220	1.440	1.340	1.140
	1.800	2.000	1.860	1.580	1.820	1.680	1.440	1.620	1.500	1.280	1.480	1.380	1.160	1.400	1.300	1.100
	2.000	1.940	1.800	1.540	1.760	1.640	1.400	1.560	1.440	1.240	1.440	1.340	1.140	1.340	1.240	1.060
	2.200	1.880	1.740	1.480	1.700	1.580	1.340	1.520	1.400	1.200	1.380	1.280	1.080	1.300	1.200	1.040
	2.400	1.820	1.680	1.440	1.660	1.540	1.300	1.460	1.360	1.160	1.340	1.260	1.060	1.260	1.160	1.000
	2.600	1.780	1.640	1.400	1.600	1.500	1.280	1.420	1.320	1.140	1.320	1.220	1.040	1.220	1.140	0.980

SECTION(S):  
34820 + 35829

DESCRIPTION:  
HINGED DOOR MULLION & ENTRANCE DOOR STILE

DATA:  
MOMENT OF INERTIA - 383198.58 mm<sup>4</sup>

DEFLECTION MAX.:  
15mm

1:2 SCALE

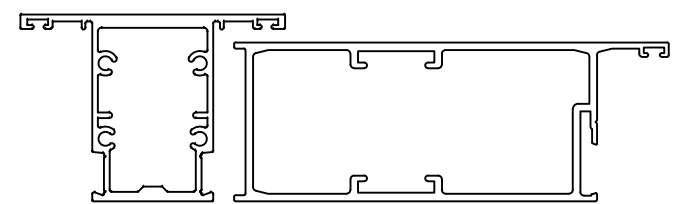

MULLION DATA - Mullion spacing and span calculations are to the current NZS 4211:2008  
Tables shall be used only where no Specific Design wind pressures are specified by the designers. The data provided is given for guidance only and the manufacturer takes no responsibility for incorrect interpretation. It is recommended that a qualified designer be consulted before fabrication.  
SPAN (m) - ULTIMATE (UWP) - SERVICEABILITY (SWP)  
SPAN / DEFLECTION (SPAN / DEF) = RESIDENTIAL 200 min, COMMERCIAL 250 min.

WIND ZONE:	LOW	720 Pa (UWP)		MEDIUM 960 Pa (UWP)		HIGH	1360 Pa (UWP)		VERY HIGH	1760 Pa (UWP)		EXTRA HIGH	2130 Pa (UWP)	
		250 Pa (SWP)	400 Pa (SWP)	200 Pa (SWP)	250 Pa (SWP)		250 Pa (SWP)	400 Pa (SWP)		250 Pa (SWP)	400 Pa (SWP)		200 Pa (SWP)	250 Pa (SWP)
MULLION LOAD SPACING (m)	0.600	3.140	2.860	2.540	2.900	2.700	2.380	2.580	2.400	2.040	2.380	2.220	2.060	1.760
	0.800	2.900	2.700	2.300	2.640	2.460	2.100	2.340	2.180	1.860	2.100	2.020	1.860	1.600
	1.000	2.700	2.500	2.140	2.460	2.260	1.940	2.180	2.020	1.720	2.000	1.880	1.740	1.480
	1.200	2.540	2.360	2.020	2.300	2.140	1.820	2.040	1.860	1.620	1.880	1.760	1.640	1.400
	1.400	2.420	2.240	1.920	2.200	2.040	1.740	1.940	1.800	1.540	1.780	1.660	1.420	1.320
	1.600	2.300	2.140	1.820	2.100	1.940	1.660	1.860	1.720	1.460	1.700	1.600	1.400	1.260
	1.800	2.220	2.060	1.760	2.020	1.860	1.600	1.780	1.680	1.420	1.640	1.520	1.300	1.220
	2.000	2.140	1.980	1.700	1.940	1.800	1.540	1.720	1.600	1.360	1.580	1.480	1.260	1.180
	2.200	2.080	1.920	1.640	1.880	1.740	1.500	1.680	1.560	1.320	1.540	1.440	1.220	1.140
	2.400	2.020	1.860	1.600	1.820	1.700	1.440	1.620	1.500	1.280	1.500	1.400	1.200	1.100
	2.600	1.960	1.820	1.560	1.780	1.680	1.420	1.580	1.460	1.260	1.480	1.360	1.160	1.080

SECTION(S):  
35820 + 35821

DESCRIPTION:  
FRENCH DOOR STILES

DATA:  
MOMENT OF INERTIA - 362646.66 mm<sup>4</sup>

DEFLECTION MAX.:  
15mm

1:2 SCALE

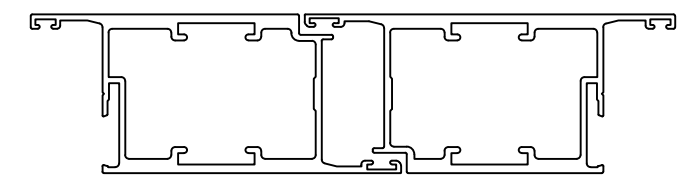

MULLION DATA - Mullion spacing and span calculations are to the current NZS 4211:2008  
Tables shall be used only where no Specific Design wind pressures are specified by the designers. The data provided is given for guidance only and the manufacturer takes no responsibility for incorrect interpretation. It is recommended that a qualified designer be consulted before fabrication.  
SPAN (m) - ULTIMATE (UWP) - SERVICEABILITY (SWP)  
SPAN / DEFLECTION (SPAN / DEF) = RESIDENTIAL 200 min, COMMERCIAL 250 min.

WIND ZONE:	LOW	720 Pa (UWP)		MEDIUM 960 Pa (UWP)		HIGH	1360 Pa (UWP)		VERY HIGH	1760 Pa (UWP)		EXTRA HIGH	2130 Pa (UWP)	
		250 Pa (SWP)	400 Pa (SWP)	200 Pa (SWP)	250 Pa (SWP)		250 Pa (SWP)	400 Pa (SWP)		250 Pa (SWP)	400 Pa (SWP)		200 Pa (SWP)	250 Pa (SWP)
MULLION LOAD SPACING (m)	0.600	3.100	2.820	2.500	2.860	2.660	2.340	2.540	2.360	2.020	2.340	2.180	2.020	1.740
	0.800	2.860	2.680	2.380	2.600	2.420	2.080	2.320	2.140	1.840	2.120	1.960	1.800	1.580
	1.000	2.660	2.460	2.100	2.420	2.240	1.920	2.140	2.000	1.700	1.960	1.820	1.560	1.460
	1.200	2.500	2.320	1.980	2.280	2.100	1.800	2.020	1.860	1.600	1.860	1.740	1.580	1.380
	1.400	-	-	-	-	-	-	-	-	-	-	-	-	-
	1.600	-	-	-	-	-	-	-	-	-	-	-	-	-
	1.800	-	-	-	-	-	-	-	-	-	-	-	-	-
	2.000	-	-	-	-	-	-	-	-	-	-	-	-	-
	2.200	-	-	-	-	-	-	-	-	-	-	-	-	-
	2.400	-	-	-	-	-	-	-	-	-	-	-	-	-
	2.600	-	-	-	-	-	-	-	-	-	-	-	-	-

REV#	DESCRIPTION	DATE
A	Page Updated	03-08-16

MULLION SPAN TABLES

SCALE	1:2 @ A3
NAME	DATE
DRAWN	T.S 12/2013
CHECKED	M.C 00/2013



DRAWING No.
309.T.01

HINGED DOOR

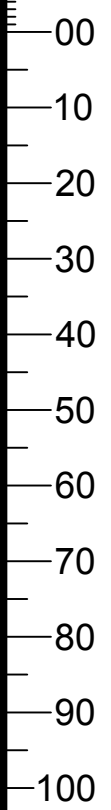

COPYRIGHT © 2011 MCKECHNIE ALUMINIUM SOLUTIONS LIMITED.  
PLEASE CHECK THAT ALL DETAILS ARE UP TO DATE BEFORE  
PROCEEDING. IF IN DOUBT ASK.

SECTION(S):  
36590 + 35819

DESCRIPTION:  
ENTRANCE DOOR MULLION & STANDARD DOOR STILE

DATA:  
MOMENT OF INERTIA - 415875 mm<sup>4</sup>  
DEFLECTION MAX.:  
15mm

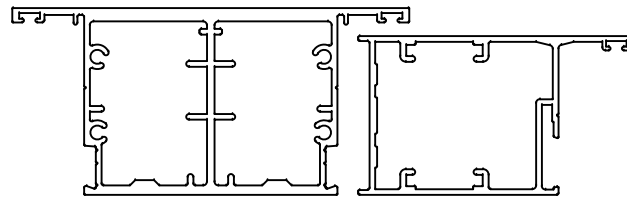

1:2 SCALE

MULLION DATA - Mullion spacing and span calculations are to the current NZS 4211:2008. Tables shall be used only where no Specific Design wind pressures are specified by the designers. The data provided is given for guidance only and the manufacturer takes no responsibility for incorrect interpretation. It is recommended that a qualified designer be consulted before fabrication.  
SPAN (m) - ULTIMATE (UWP) - SERVICEABILITY (SWP)  
SPAN / DEFLECTION (SPAN / DEF) = RESIDENTIAL 200 min, COMMERCIAL 250 min.

Table with columns for WIND ZONE (LOW, MEDIUM, HIGH, VERY HIGH, EXTRA HIGH), SPAN / DEF, and various wind speed and pressure values (Pa (UWP), Pa (SWP)) for different mullion spacings (0.600m to 2.600m).

SECTION(S):  
36590 + 36186

DESCRIPTION:  
ENTRANCE DOOR MULLION & 40mm BACKSET  
HINGED DOOR STILE

DATA:  
MOMENT OF INERTIA - 449826 mm<sup>4</sup>  
DEFLECTION MAX.:  
15mm

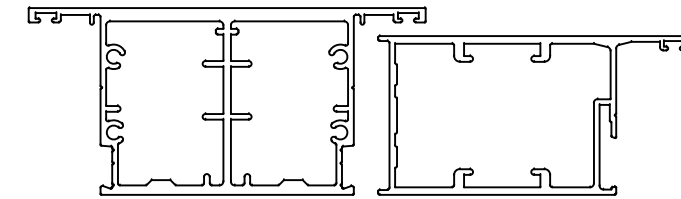

1:2 SCALE

MULLION DATA - Mullion spacing and span calculations are to the current NZS 4211:2008. Tables shall be used only where no Specific Design wind pressures are specified by the designers. The data provided is given for guidance only and the manufacturer takes no responsibility for incorrect interpretation. It is recommended that a qualified designer be consulted before fabrication.  
SPAN (m) - ULTIMATE (UWP) - SERVICEABILITY (SWP)  
SPAN / DEFLECTION (SPAN / DEF) = RESIDENTIAL 200 min, COMMERCIAL 250 min.

Table with columns for WIND ZONE (LOW, MEDIUM, HIGH, VERY HIGH, EXTRA HIGH), SPAN / DEF, and various wind speed and pressure values (Pa (UWP), Pa (SWP)) for different mullion spacings (0.600m to 2.600m).

HINGED DOOR

SECTION(S):  
36590 + 35829

DESCRIPTION:  
HINGED DOOR HEAVY MULLION & 50mm B/S  
T & G BEADED DOOR STILE

DATA:  
MOMENT OF INERTIA - 511271 mm<sup>4</sup>  
DEFLECTION MAX.:  
15mm

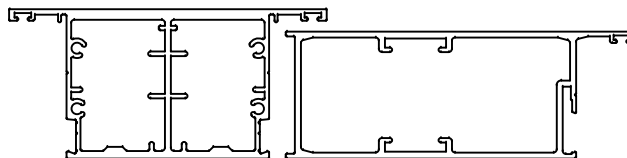

1:2.5 SCALE

MULLION DATA - Mullion spacing and span calculations are to the current NZS 4211:2008. Tables shall be used only where no Specific Design wind pressures are specified by the designers. The data provided is given for guidance only and the manufacturer takes no responsibility for incorrect interpretation. It is recommended that a qualified designer be consulted before fabrication.  
SPAN (m) - ULTIMATE (UWP) - SERVICEABILITY (SWP)  
SPAN / DEFLECTION (SPAN / DEF) = RESIDENTIAL 200 min, COMMERCIAL 250 min.

Table with columns for WIND ZONE (LOW, MEDIUM, HIGH, VERY HIGH, EXTRA HIGH), SPAN / DEF, and various wind speed and pressure values (Pa (UWP), Pa (SWP)) for different mullion spacings (0.600m to 2.600m).

SECTION(S):  
36590 + 36262

DESCRIPTION:  
HINGED DOOR HEAVY MULLION & STRUCTURAL  
GLAZED STILE

DATA:  
MOMENT OF INERTIA - 805769.84 mm<sup>4</sup>  
DEFLECTION MAX.:  
15mm

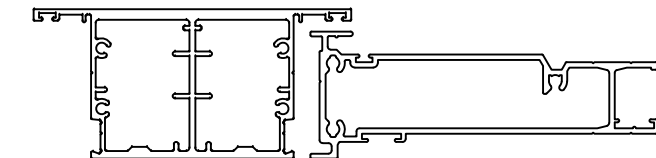

1:2.5 SCALE

MULLION DATA - Mullion spacing and span calculations are to the current NZS 4211:2008. Tables shall be used only where no Specific Design wind pressures are specified by the designers. The data provided is given for guidance only and the manufacturer takes no responsibility for incorrect interpretation. It is recommended that a qualified designer be consulted before fabrication.  
SPAN (m) - ULTIMATE (UWP) - SERVICEABILITY (SWP)  
SPAN / DEFLECTION (SPAN / DEF) = RESIDENTIAL 200 min, COMMERCIAL 250 min.

Table with columns for WIND ZONE (LOW, MEDIUM, HIGH, VERY HIGH, EXTRA HIGH), SPAN / DEF, and various wind speed and pressure values (Pa (UWP), Pa (SWP)) for different mullion spacings (0.600m to 2.600m).

Revision table with columns: REV#, DESCRIPTION, DATE. Includes entries for 36185 Replaced 35830 and Page Updated.

STILE / COUPLING SPAN TABLES

Scale and drawing information table with columns: SCALE, NAME, DATE, DRAWN, CHECKED.



DRAWING No.  
309.T.02

COPYRIGHT © 2011 MCKECHNIE ALUMINIUM SOLUTIONS LIMITED. PLEASE CHECK THAT ALL DETAILS ARE UP TO DATE BEFORE PROCEEDING. IF IN DOUBT ASK.









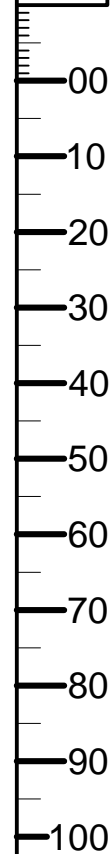

311

# Sliding Doors Span Charts

REV#	DESCRIPTION	DATE
-	-	00/2013
-	-	00/2013
-	-	00/2013
-	-	00/00/2013

SPAN CHART

SCALE	NTS	
	NAME	DATE
DRAWN	ADM	05/10/17
CHECKED		



DRAWING No. 300 SERIES SP

SECTION(S):  
35806 + 35810

DESCRIPTION:  
STANDARD INTERLOCKER MULLION + STILE

DATA:  
MOMENT OF INERTIA - 324111 mm<sup>4</sup>

DEFLECTION MAX:  
15mm

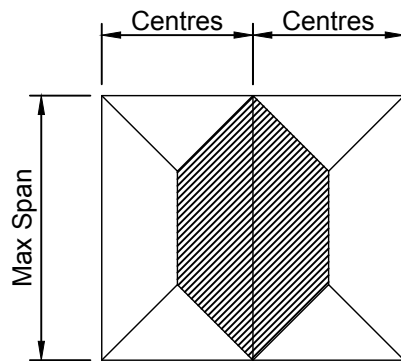
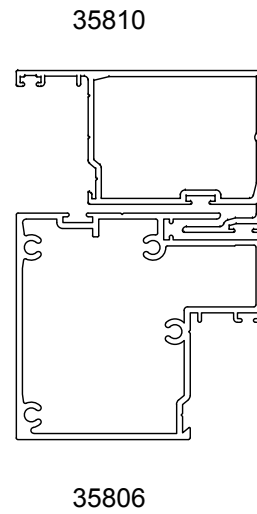

MULLION DATA - Mullion spacing and span calculations are to the current NZS 4211:2008  
Tables shall be used only where no Specific Design wind pressures are specified by the designers. The data provided is given for guidance only and the manufacturer takes no responsibility for incorrect interpretation. It is recommended that a qualified designer be consulted before fabrication.  
SPAN (m) - ULTIMATE (UWP) - SERVICEABILITY (SWP)  
SPAN / DEFLECTION (SPAN / DEF) = RESIDENTIAL 200 min

WIND ZONE :	LOW	MEDIUM	HIGH	VERY HIGH	EXTRA HIGH	
SPAN / DEF. :	200	200	200	200	200	
MULLION LOAD SPACING (m)	0.600	3.020	2.760	2.440	2.240	2.100
	0.800	2.760	2.500	2.220	2.040	1.920
	1.000	2.560	2.320	2.060	1.900	1.780
	1.200	2.400	2.180	1.940	1.780	1.660
	1.400	2.280	2.080	1.840	1.680	1.580
	1.600	2.180	1.980	1.760	1.620	1.520
	1.800	2.100	1.900	1.700	1.560	1.460
	2.000	2.020	1.840	1.640	1.500	1.400
	2.200	1.960	1.780	1.580	1.460	1.360
	2.400	1.900	1.720	1.540	1.400	1.320
2.600	1.860	1.680	1.500	1.380	1.280	

SECTION(S):  
35807 + 35810

DESCRIPTION:  
HEAVY INTERLOCKER MULLION + STILE

DATA:  
MOMENT OF INERTIA - 968698 mm<sup>4</sup>

DEFLECTION MAX:  
15mm

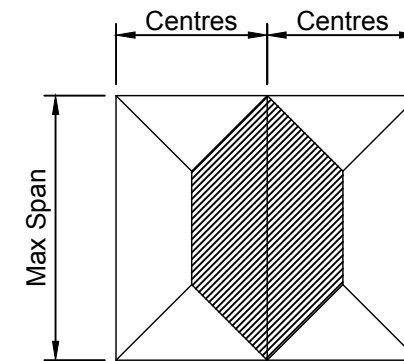
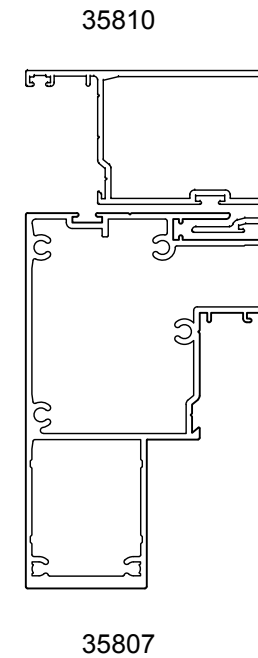

MULLION DATA - Mullion spacing and span calculations are to the current NZS 4211:2008  
Tables shall be used only where no Specific Design wind pressures are specified by the designers. The data provided is given for guidance only and the manufacturer takes no responsibility for incorrect interpretation. It is recommended that a qualified designer be consulted before fabrication.  
SPAN (m) - ULTIMATE (UWP) - SERVICEABILITY (SWP)  
SPAN / DEFLECTION (SPAN / DEF) = RESIDENTIAL 200 min

WIND ZONE :	LOW	MEDIUM	HIGH	VERY HIGH	EXTRA HIGH	
SPAN / DEF. :	200	200	200	200	200	
MULLION LOAD SPACING (m)	0.600	3.980	3.700	3.380	3.180	3.020
	0.800	3.700	3.440	3.140	2.940	2.760
	1.000	3.500	3.260	2.960	2.720	2.560
	1.200	3.340	3.100	2.800	2.560	2.400
	1.400	3.220	2.980	2.660	2.440	2.280
	1.600	3.100	2.860	2.540	2.340	2.180
	1.800	3.020	2.740	2.440	2.240	2.100
	2.000	2.920	2.660	2.360	2.160	2.020
	2.200	2.820	2.560	2.280	2.100	1.960
	2.400	2.740	2.500	2.220	2.040	1.900
2.600	2.680	2.420	2.160	1.980	1.860	

REV#	DESCRIPTION	DATE

## SPAN TABLES

SCALE	1:2 @ A3
NAME	
DRAWN	T.S 12/2013
CHECKED	M.C 00/2013



DRAWING No.

311.3.2

SLIDING DOOR

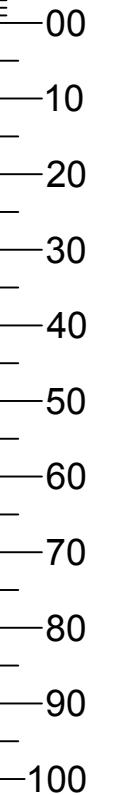

COPYRIGHT © 2011 MCKECHNIE ALUMINIUM SOLUTIONS LIMITED.  
PLEASE CHECK THAT ALL DETAILS ARE UP TO DATE BEFORE  
PROCEEDING. IF IN DOUBT ASK  
A3 ORIGINAL SIZE

SECTION(S):  
35806 + 36281

DESCRIPTION:  
STANDARD MULLION + HEAVY DUTY  
INTERLOCKER STILE

DATA:  
MOMENT OF INERTIA - 987837 mm<sup>4</sup>

DEFLECTION MAX:  
15mm

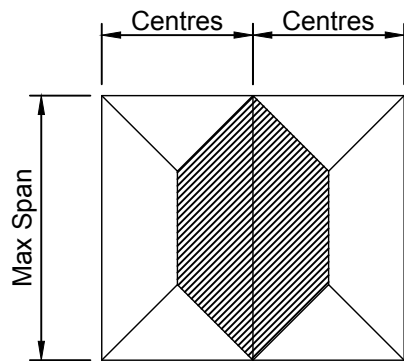
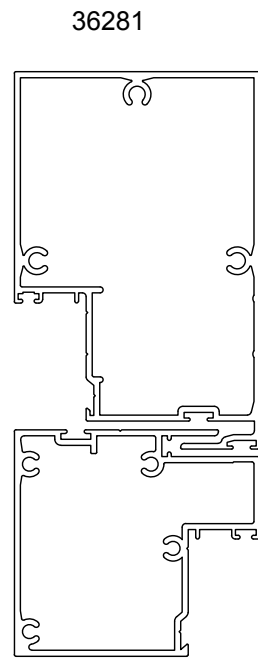

MULLION DATA - Mullion spacing and span calculations are to the current NZS 4211:2008  
Tables shall be used only where no Specific Design wind pressures are specified by the designers. The data provided is given for guidance only and the manufacturer takes no responsibility for incorrect interpretation. It is recommended that a qualified designer be consulted before fabrication.  
SPAN (m) - ULTIMATE (UWP) - SERVICEABILITY (SWP)  
SPAN / DEFLECTION (SPAN / DEF) = RESIDENTIAL 200 min

WIND ZONE :	LOW	MEDIUM	HIGH	VERY HIGH	EXTRA HIGH	
SPAN / DEF. :	200	200	200	200	200	
MULLION LOAD SPACING (m)	0.600	4.000	3.720	3.400	3.180	3.040
	0.800	3.720	3.460	3.160	2.960	2.780
	1.000	3.520	3.260	2.980	2.740	2.580
	1.200	3.360	3.120	2.820	2.580	2.420
	1.400	3.220	3.000	2.680	2.460	2.300
	1.600	3.120	2.880	2.560	2.340	2.200
	1.800	3.040	2.760	2.460	2.260	2.120
	2.000	2.940	2.660	2.380	2.180	2.040
	2.200	2.840	2.580	2.300	2.100	1.980
	2.400	2.760	2.520	2.240	2.040	1.920
2.600	2.700	2.440	2.180	2.000	1.880	

SECTION(S):  
35807 + 36281

DESCRIPTION:  
HEAVY MULLION + HEAVY DUTY  
INTERLOCKER STILE

DATA:  
MOMENT OF INERTIA - 1632425 mm<sup>4</sup>

DEFLECTION MAX:  
15mm

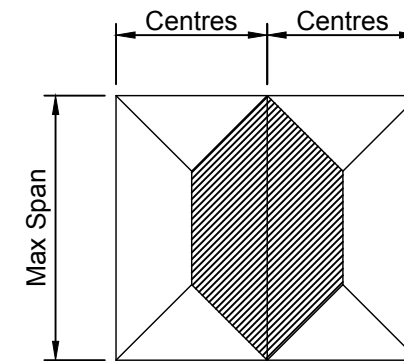
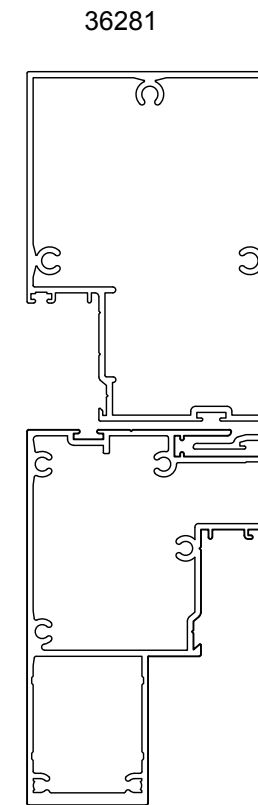

MULLION DATA - Mullion spacing and span calculations are to the current NZS 4211:2008  
Tables shall be used only where no Specific Design wind pressures are specified by the designers. The data provided is given for guidance only and the manufacturer takes no responsibility for incorrect interpretation. It is recommended that a qualified designer be consulted before fabrication.  
SPAN (m) - ULTIMATE (UWP) - SERVICEABILITY (SWP)  
SPAN / DEFLECTION (SPAN / DEF) = RESIDENTIAL 200 min

WIND ZONE :	LOW	MEDIUM	HIGH	VERY HIGH	EXTRA HIGH	
SPAN / DEF. :	200	200	200	200	200	
MULLION LOAD SPACING (m)	0.600	4.520	4.220	3.860	3.620	3.440
	0.800	4.220	3.920	3.580	3.360	3.200
	1.000	3.980	3.700	3.400	3.180	3.040
	1.200	3.800	3.540	3.240	3.040	2.860
	1.400	3.660	3.400	3.120	2.900	2.720
	1.600	3.540	3.300	3.020	2.780	2.600
	1.800	3.440	3.200	2.900	2.660	2.500
	2.000	3.340	3.120	2.800	2.580	2.420
	2.200	3.260	3.040	2.720	2.500	2.340
	2.400	3.200	2.980	2.640	2.420	2.280
2.600	3.140	2.900	2.560	2.360	2.220	

REV#	DESCRIPTION	DATE

## SPAN TABLES

SCALE	1:2 @ A3
NAME	
DRAWN	T.S
CHECKED	M.C



DRAWING No.

311.3.3

SLIDING DOOR

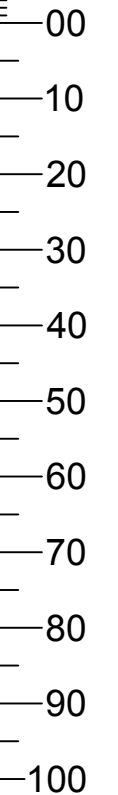

COPYRIGHT © 2011 MCKECHNIE ALUMINIUM SOLUTIONS LIMITED.  
PLEASE CHECK THAT ALL DETAILS ARE UP TO DATE BEFORE  
PROCEEDING. IF IN DOUBT ASK.

SECTION(S):  
35814 + 35810

DESCRIPTION:  
REVERSE INTERLOCKER STILES

DATA:  
MOMENT OF INERTIA - 177797 mm<sup>4</sup>

DEFLECTION MAX:  
15mm

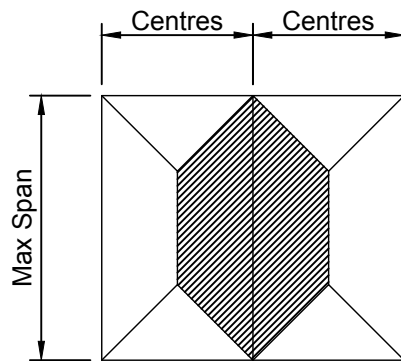
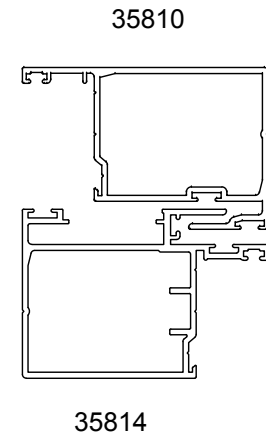

MULLION DATA - Mullion spacing and span calculations are to the current NZS 4211:2008  
Tables shall be used only where no Specific Design wind pressures are specified by the designers. The data provided is given for guidance only and the manufacturer takes no responsibility for incorrect interpretation. It is recommended that a qualified designer be consulted before fabrication.  
SPAN (m) - ULTIMATE (UWP) - SERVICEABILITY (SWP)  
SPAN / DEFLECTION (SPAN / DEF) = RESIDENTIAL 200 min

WIND ZONE :	LOW	MEDIUM	HIGH	VERY HIGH	EXTRA HIGH	
SPAN / DEF. :	200	200	200	200	200	
MULLION LOAD SPACING (m)	0.600	2.480	2.260	2.000	1.840	1.720
	0.800	2.260	2.040	1.820	1.660	1.560
	1.000	2.080	1.900	1.680	1.540	1.440
	1.200	1.960	1.780	1.580	1.460	1.360
	1.400	1.860	1.700	1.500	1.380	1.300
	1.600	1.780	1.620	1.440	1.320	1.240
	1.800	1.720	1.560	1.380	1.260	1.180
	2.000	1.660	1.500	1.340	1.220	1.140
	2.200	1.600	1.460	1.300	1.180	1.120
	2.400	1.560	1.420	1.260	1.160	1.080
2.600	1.520	1.380	1.220	1.120	1.060	

SECTION(S):  
35815 + 35810

DESCRIPTION:  
HEAVY REVERSE INTERLOCKER STILES

DATA:  
MOMENT OF INERTIA - 723138 mm<sup>4</sup>

DEFLECTION MAX:  
15mm

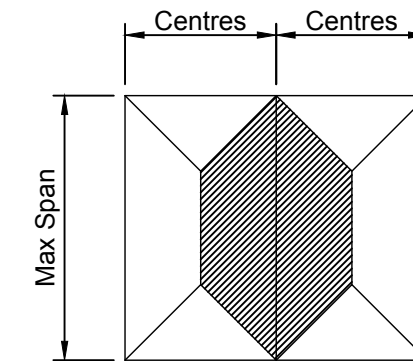
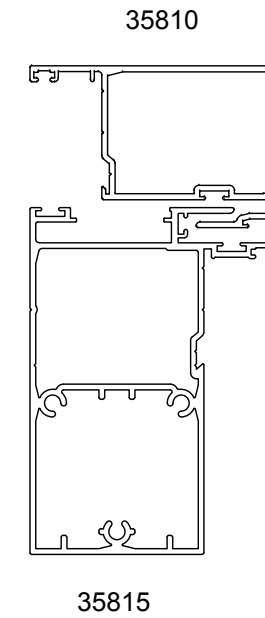

MULLION DATA - Mullion spacing and span calculations are to the current NZS 4211:2008  
Tables shall be used only where no Specific Design wind pressures are specified by the designers. The data provided is given for guidance only and the manufacturer takes no responsibility for incorrect interpretation. It is recommended that a qualified designer be consulted before fabrication.  
SPAN (m) - ULTIMATE (UWP) - SERVICEABILITY (SWP)  
SPAN / DEFLECTION (SPAN / DEF) = RESIDENTIAL 200 min

WIND ZONE :	LOW	MEDIUM	HIGH	VERY HIGH	EXTRA HIGH	
SPAN / DEF. :	200	200	200	200	200	
MULLION LOAD SPACING (m)	0.600	3.700	3.440	3.140	2.940	2.760
	0.800	3.440	3.200	2.900	2.660	2.500
	1.000	3.240	3.020	2.700	2.480	2.320
	1.200	3.100	2.860	2.540	2.320	2.180
	1.400	2.980	2.720	2.400	2.220	2.080
	1.600	2.860	2.600	2.300	2.120	1.980
	1.800	2.740	2.500	2.220	2.040	1.900
	2.000	2.640	2.400	2.140	1.960	1.840
	2.200	2.560	2.320	2.060	1.900	1.780
	2.400	2.500	2.260	2.000	1.840	1.740
2.600	2.420	2.200	1.960	1.800	1.680	

REV#	DESCRIPTION	DATE

## SPAN TABLES

SCALE	1:2 @ A3
NAME	
DRAWN	T.S
CHECKED	M.C



DRAWING No.

311.3.4

SLIDING DOOR

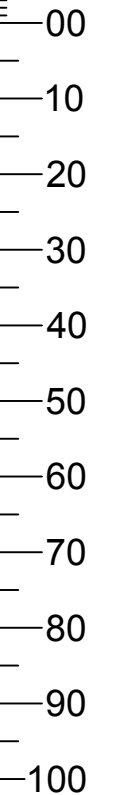

COPYRIGHT © 2011 MCKECHNIE ALUMINIUM SOLUTIONS LIMITED.  
PLEASE CHECK THAT ALL DETAILS ARE UP TO DATE BEFORE  
PROCEEDING. IF IN DOUBT ASK.

SECTION(S):  
35814 + 36281

DESCRIPTION:  
REVERSE INTERLOCK STILE + HEAVY DUTY  
INTERLOCKER STILE

DATA:  
MOMENT OF INERTIA - 841523 mm<sup>4</sup>

DEFLECTION MAX:  
15mm

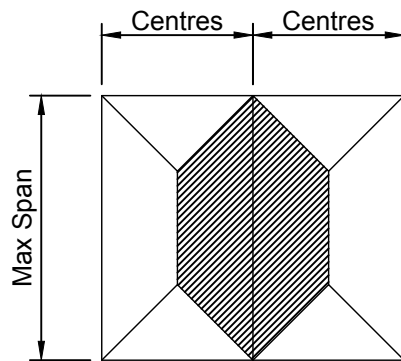
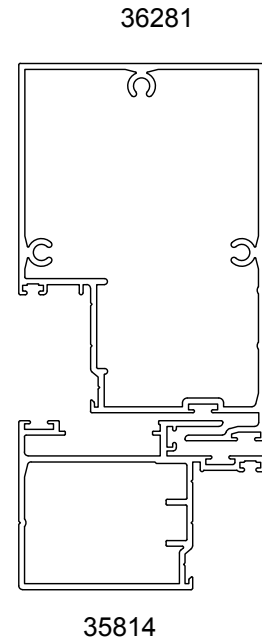

MULLION DATA - Mullion spacing and span calculations are to the current NZS 4211:2008  
Tables shall be used only where no Specific Design wind pressures are specified by the designers. The data provided is given for guidance only and the manufacturer takes no responsibility for incorrect interpretation. It is recommended that a qualified designer be consulted before fabrication.  
SPAN (m) - ULTIMATE (UWP) - SERVICEABILITY (SWP)  
SPAN / DEFLECTION (SPAN / DEF) = RESIDENTIAL 200 min

WIND ZONE :	LOW	MEDIUM	HIGH	VERY HIGH	EXTRA HIGH	
SPAN / DEF. :	200	200	200	200	200	
MULLION LOAD SPACING (m)	0.600	3.840	3.560	3.260	3.060	2.900
	0.800	3.560	3.320	3.040	2.800	2.620
	1.000	3.380	3.140	2.840	2.600	2.440
	1.200	3.220	3.000	2.660	2.440	2.300
	1.400	3.100	2.860	2.540	2.320	2.180
	1.600	3.000	2.720	2.420	2.220	2.080
	1.800	2.880	2.620	2.320	2.140	2.000
	2.000	2.780	2.540	2.240	2.060	1.940
	2.200	2.700	2.460	2.180	2.000	1.880
	2.400	2.620	2.380	2.120	1.940	1.820
2.600	2.560	2.320	2.060	1.900	1.780	

SECTION(S):  
35815 + 36281

DESCRIPTION:  
HEAVY REVERSE INTERLOCKER + HEAVY  
DUTY INTERLOCKER STILE

DATA:  
MOMENT OF INERTIA - 1386864 mm<sup>4</sup>

DEFLECTION MAX:  
15mm

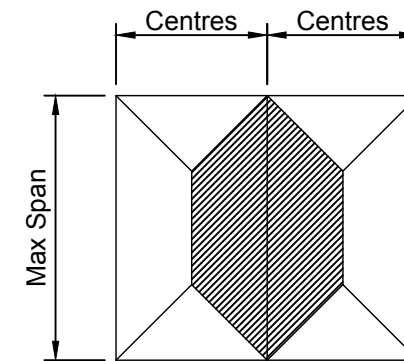
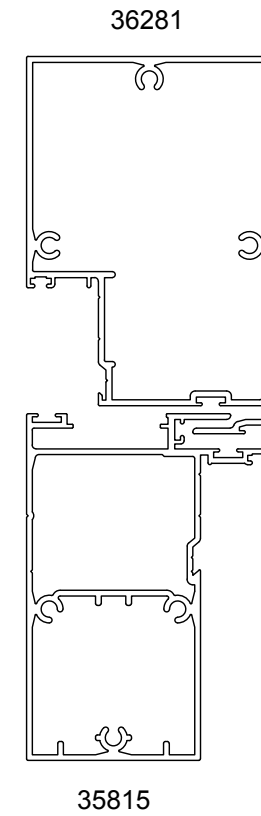

MULLION DATA - Mullion spacing and span calculations are to the current NZS 4211:2008  
Tables shall be used only where no Specific Design wind pressures are specified by the designers. The data provided is given for guidance only and the manufacturer takes no responsibility for incorrect interpretation. It is recommended that a qualified designer be consulted before fabrication.  
SPAN (m) - ULTIMATE (UWP) - SERVICEABILITY (SWP)  
SPAN / DEFLECTION (SPAN / DEF) = RESIDENTIAL 200 min

WIND ZONE :	LOW	MEDIUM	HIGH	VERY HIGH	EXTRA HIGH	
SPAN / DEF. :	200	200	200	200	200	
MULLION LOAD SPACING (m)	0.600	4.340	4.040	3.700	3.480	3.300
	0.800	4.040	3.760	3.440	3.240	3.080
	1.000	3.820	3.560	3.260	3.060	2.880
	1.200	3.660	3.400	3.100	2.900	2.720
	1.400	3.520	3.280	3.000	2.740	2.580
	1.600	3.400	3.160	2.860	2.620	2.460
	1.800	3.300	3.080	2.760	2.520	2.360
	2.000	3.220	3.000	2.660	2.440	2.280
	2.200	3.140	2.900	2.580	2.360	2.220
	2.400	3.080	2.820	2.500	2.300	2.160
2.600	3.000	2.740	2.440	2.240	2.100	

REV#	DESCRIPTION	DATE

## SPAN TABLES

SCALE	1:2 @ A3
NAME	DATE
DRAWN	T.S 12/2013
CHECKED	M.C 00/2013



DRAWING No.

311.3.5

SLIDING DOOR

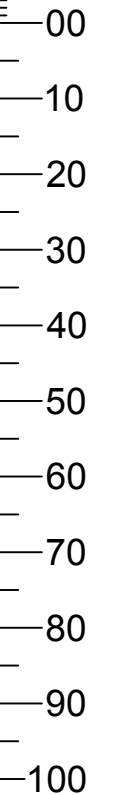

COPYRIGHT © 2011 MCKECHNIE ALUMINIUM SOLUTIONS LIMITED.  
PLEASE CHECK THAT ALL DETAILS ARE UP TO DATE BEFORE  
PROCEEDING. IF IN DOUBT ASK.



SECTION(S):  
35812 + 36013 + 35812

DESCRIPTION:  
4 PANEL MEETING STILES

DATA:  
MOMENT OF INERTIA - 214892 mm<sup>4</sup>

DEFLECTION MAX:  
15mm

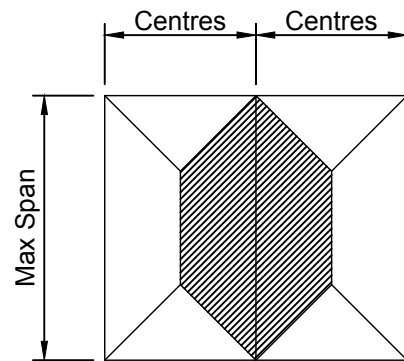
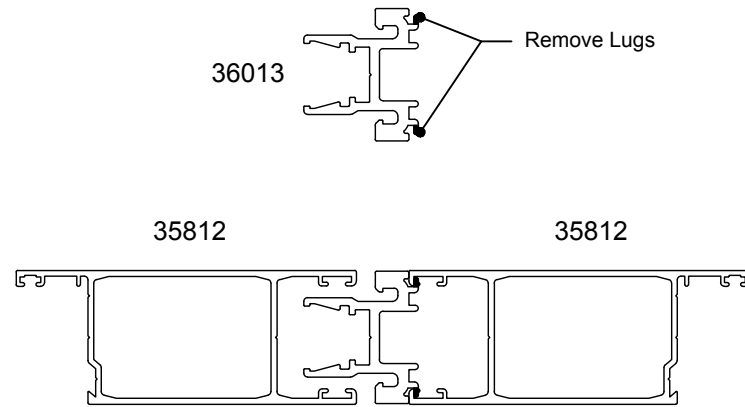

MULLION DATA - Mullion spacing and span calculations are to the current NZS 4211:2008  
Tables shall be used only where no Specific Design wind pressures are specified by the designers. The data provided is given for guidance only and the manufacturer takes no responsibility for incorrect interpretation. It is recommended that a qualified designer be consulted before fabrication.  
SPAN (m) - ULTIMATE (UWP) - SERVICEABILITY (SWP)  
SPAN / DEFLECTION (SPAN / DEF) = RESIDENTIAL 200 min

WIND ZONE :	LOW	MEDIUM	HIGH	VERY HIGH	EXTRA HIGH	
SPAN / DEF. :	200	200	200	200	200	
MULLION LOAD SPACING (m)	0.600	2.640	2.400	2.120	1.960	1.840
	0.800	2.400	2.180	1.940	1.780	1.660
	1.000	2.220	2.020	1.800	1.640	1.540
	1.200	2.100	1.900	1.680	1.540	1.460
	1.400	1.980	1.800	1.600	1.480	1.380
	1.600	1.900	1.720	1.540	1.400	1.320
	1.800	1.820	1.660	1.480	1.360	1.260
	2.000	1.760	1.600	1.420	1.300	1.220
	2.200	1.700	1.560	1.380	1.260	1.180
	2.400	1.660	1.500	1.340	1.220	1.160
2.600	1.620	1.460	1.300	1.200	1.120	

SECTION(S):  
35812 + 35813

DESCRIPTION:  
4 PANEL MEETING STILES

DATA:  
MOMENT OF INERTIA - 624029 mm<sup>4</sup>

DEFLECTION MAX:  
15mm

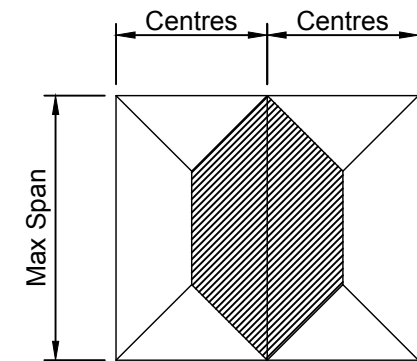
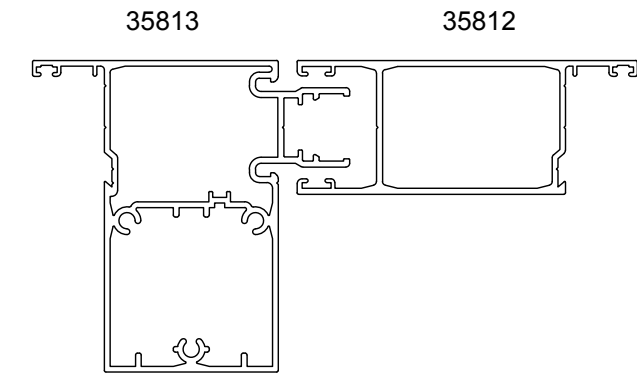

MULLION DATA - Mullion spacing and span calculations are to the current NZS 4211:2008  
Tables shall be used only where no Specific Design wind pressures are specified by the designers. The data provided is given for guidance only and the manufacturer takes no responsibility for incorrect interpretation. It is recommended that a qualified designer be consulted before fabrication.  
SPAN (m) - ULTIMATE (UWP) - SERVICEABILITY (SWP)  
SPAN / DEFLECTION (SPAN / DEF) = RESIDENTIAL 200 min

WIND ZONE :	LOW	MEDIUM	HIGH	VERY HIGH	EXTRA HIGH	
SPAN / DEF. :	200	200	200	200	200	
MULLION LOAD SPACING (m)	0.600	3.560	3.320	3.020	2.800	2.620
	0.800	3.320	3.080	2.760	2.540	2.380
	1.000	3.140	2.880	2.560	2.360	2.200
	1.200	3.000	2.720	2.420	2.220	2.080
	1.400	2.840	2.580	2.300	2.100	1.980
	1.600	2.720	2.460	2.200	2.020	1.880
	1.800	2.620	2.380	2.100	1.940	1.820
	2.000	2.520	2.280	2.040	1.860	1.760
	2.200	2.440	2.220	1.960	1.800	1.700
	2.400	2.380	2.160	1.920	1.760	1.640
2.600	2.300	2.100	1.860	1.700	1.600	

REV#	DESCRIPTION	DATE

## SPAN TABLES

SCALE	1:2 @ A3
NAME	
DATE	
DRAWN	T.S
CHECKED	M.C



DRAWING No.

311.3.6

SLIDING DOOR

00  
10  
20  
30  
40  
50  
60  
70  
80  
90  
100

COPYRIGHT © 2011 MCKECHNIE ALUMINIUM SOLUTIONS LIMITED.  
PLEASE CHECK THAT ALL DETAILS ARE UP TO DATE BEFORE  
PROCEEDING. IF IN DOUBT ASK.

SECTION(S):  
35808

DESCRIPTION:  
3 PANEL MULLION / OVERLIGHT TRANSOM

DATA:  
MOMENT OF INERTIA - 903452 mm<sup>4</sup>

DEFLECTION MAX:  
15mm

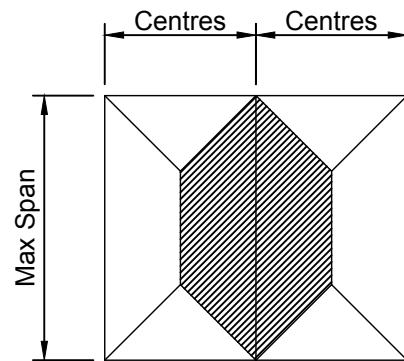
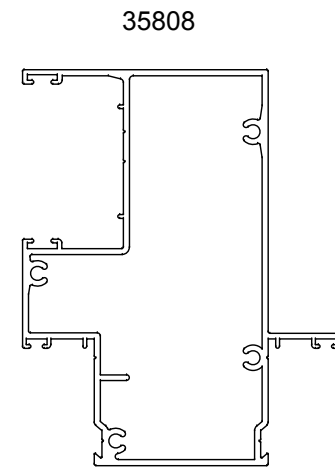

MULLION DATA - Mullion spacing and span calculations are to the current NZS 4211:2008  
Tables shall be used only where no Specific Design wind pressures are specified by the designers. The data provided is given for guidance only and the manufacturer takes no responsibility for incorrect interpretation. It is recommended that a qualified designer be consulted before fabrication.  
SPAN (m) - ULTIMATE (UWP) - SERVICEABILITY (SWP)  
SPAN / DEFLECTION (SPAN / DEF) = RESIDENTIAL 200 min

WIND ZONE :	LOW	MEDIUM	HIGH	VERY HIGH	EXTRA HIGH	
SPAN / DEF. :	200	200	200	200	200	
MULLION LOAD SPACING (m)	0.600	3.900	3.640	3.320	3.120	2.960
	0.800	3.640	3.380	3.100	2.880	2.700
	1.000	3.440	3.200	2.900	2.660	2.500
	1.200	3.280	3.060	2.720	2.500	2.360
	1.400	3.160	2.920	2.600	2.380	2.240
	1.600	3.060	2.800	2.480	2.280	2.140
	1.800	2.960	2.680	2.380	2.180	2.060
	2.000	2.860	2.600	2.300	2.120	1.980
	2.200	2.760	2.500	2.220	2.040	1.920
	2.400	2.680	2.440	2.160	1.980	1.860
2.600	2.620	2.380	2.100	1.940	1.820	

SECTION(S):  
36696

DESCRIPTION:  
3 PANEL MULLION / OVERLIGHT TRANSOM  
STACKER

DATA:  
MOMENT OF INERTIA - 2804997 mm<sup>4</sup>

DEFLECTION MAX:  
15mm

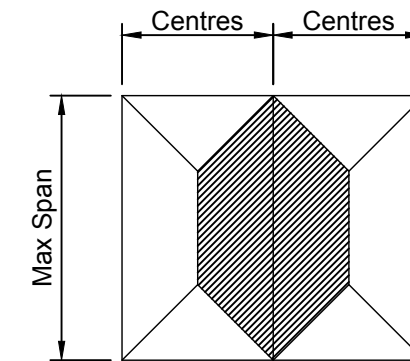
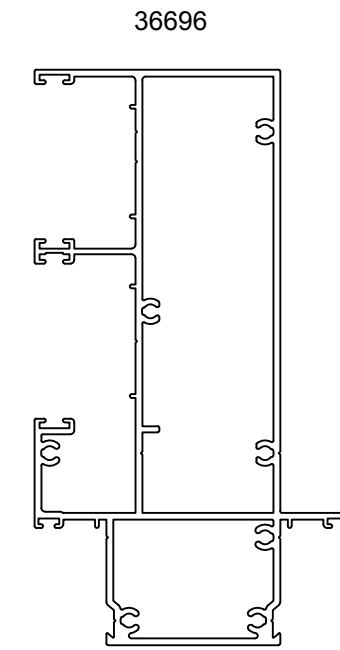

MULLION DATA - Mullion spacing and span calculations are to the current NZS 4211:2008  
Tables shall be used only where no Specific Design wind pressures are specified by the designers. The data provided is given for guidance only and the manufacturer takes no responsibility for incorrect interpretation. It is recommended that a qualified designer be consulted before fabrication.  
SPAN (m) - ULTIMATE (UWP) - SERVICEABILITY (SWP)  
SPAN / DEFLECTION (SPAN / DEF) = RESIDENTIAL 200 min

WIND ZONE :	LOW	MEDIUM	HIGH	VERY HIGH	EXTRA HIGH	
SPAN / DEF. :	200	200	200	200	200	
MULLION LOAD SPACING (m)	0.600	5.180	4.820	4.420	4.140	3.940
	0.800	4.820	4.480	4.100	3.860	3.680
	1.000	4.560	4.240	3.880	3.640	3.480
	1.200	4.360	4.060	3.720	3.480	3.320
	1.400	4.200	3.900	3.560	3.340	3.200
	1.600	4.060	3.780	3.460	3.240	3.080
	1.800	3.940	3.660	3.360	3.140	3.000
	2.000	3.840	3.560	3.260	3.060	2.900
	2.200	3.740	3.480	3.180	3.000	2.800
	2.400	3.660	3.400	3.120	2.900	2.720
2.600	3.600	3.340	3.060	2.820	2.660	

REV#	DESCRIPTION	DATE

SPAN TABLES

SCALE	1:2 @ A3
NAME	DATE
DRAWN	T.S 12/2013
CHECKED	M.C 00/2013



DRAWING No.

311.3.7

SLIDING DOOR

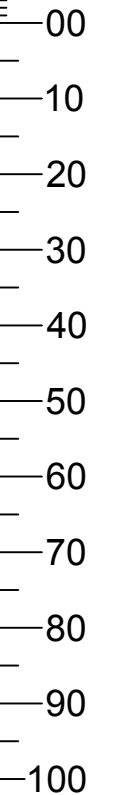

COPYRIGHT © 2011 MCKECHNIE ALUMINIUM SOLUTIONS LIMITED.  
PLEASE CHECK THAT ALL DETAILS ARE UP TO DATE BEFORE  
PROCEEDING. IF IN DOUBT ASK.

SECTION(S):  
35803 + 36185 + 36000

DESCRIPTION:  
SLIDING DOOR + MEDIUM TEE COUPLER +  
WINDOW FRAME

DATA:  
MOMENT OF INERTIA - 1625121 mm<sup>4</sup>

DEFLECTION MAX:  
15mm

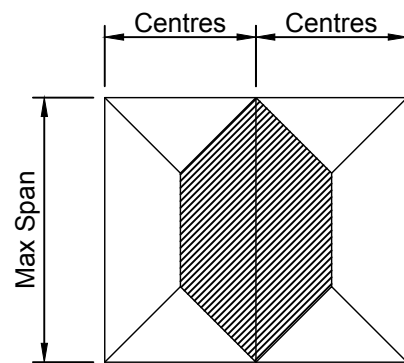
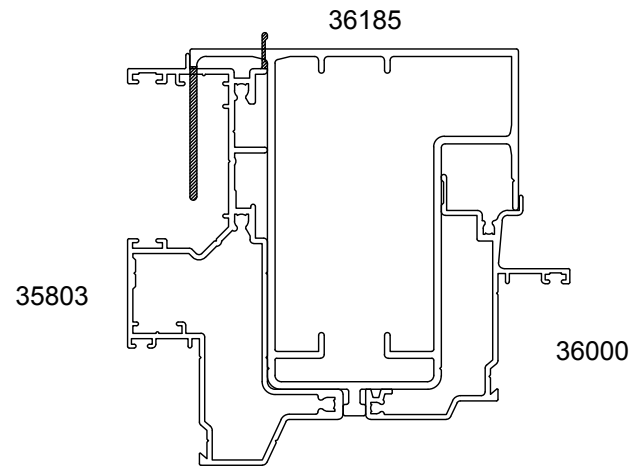

MULLION DATA - Mullion spacing and span calculations are to the current NZS 4211:2008  
Tables shall be used only where no Specific Design wind pressures are specified by the designers. The data provided is given for guidance only and the manufacturer takes no responsibility for incorrect interpretation. It is recommended that a qualified designer be consulted before fabrication.  
SPAN (m) - ULTIMATE (UWP) - SERVICEABILITY (SWP)  
SPAN / DEFLECTION (SPAN / DEF) = RESIDENTIAL 200 min

WIND ZONE :		LOW	MEDIUM	HIGH	VERY HIGH	EXTRA HIGH
SPAN / DEF. :		200	200	200	200	200
MULLION LOAD SPACING (m)	0.600	4.520	4.200	3.840	3.620	3.440
	0.800	4.200	3.920	3.580	3.360	3.200
	1.000	3.980	3.700	3.380	3.180	3.020
	1.200	3.800	3.540	3.240	3.040	2.860
	1.400	3.660	3.400	3.120	2.900	2.720
	1.600	3.540	3.300	3.020	2.780	2.600
	1.800	3.440	3.200	2.900	2.660	2.500
	2.000	3.340	3.120	2.800	2.580	2.420
	2.200	3.260	3.040	2.720	2.500	2.340
	2.400	3.200	2.960	2.640	2.420	2.260
2.600	3.140	2.880	2.560	2.360	2.200	

SECTION(S):  
35803 + 35830 + 36000

DESCRIPTION:  
SLIDING DOOR + LARGE TEE COUPLER +  
WINDOW FRAME

DATA:  
MOMENT OF INERTIA - 2369484 mm<sup>4</sup>

DEFLECTION MAX:  
15mm

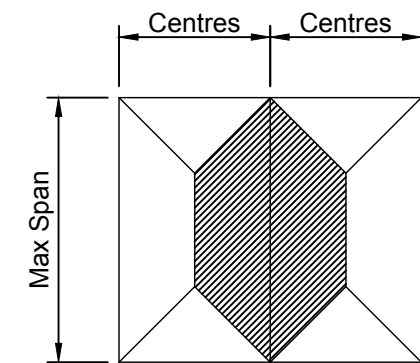
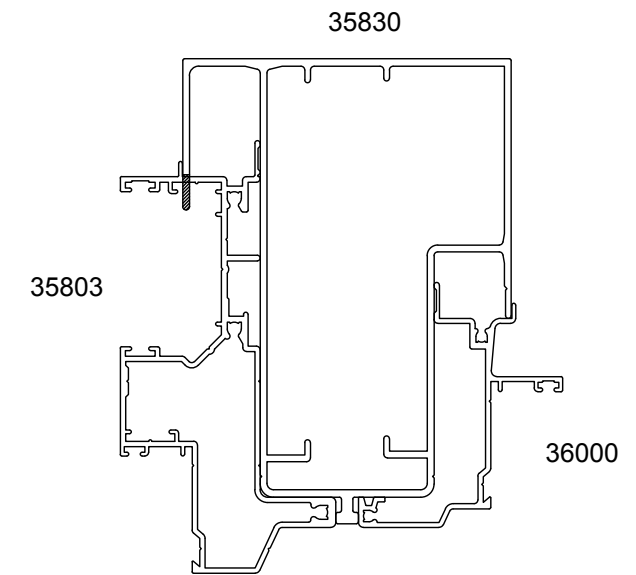

MULLION DATA - Mullion spacing and span calculations are to the current NZS 4211:2008  
Tables shall be used only where no Specific Design wind pressures are specified by the designers. The data provided is given for guidance only and the manufacturer takes no responsibility for incorrect interpretation. It is recommended that a qualified designer be consulted before fabrication.  
SPAN (m) - ULTIMATE (UWP) - SERVICEABILITY (SWP)  
SPAN / DEFLECTION (SPAN / DEF) = RESIDENTIAL 200 min

WIND ZONE :		LOW	MEDIUM	HIGH	VERY HIGH	EXTRA HIGH
SPAN / DEF. :		200	200	200	200	200
MULLION LOAD SPACING (m)	0.600	4.980	4.620	4.240	3.980	3.780
	0.800	4.620	4.300	3.940	3.700	3.520
	1.000	4.380	4.060	3.720	3.500	3.320
	1.200	4.180	3.880	3.560	3.340	3.180
	1.400	4.020	3.740	3.420	3.220	3.060
	1.600	3.880	3.620	3.300	3.100	2.940
	1.800	3.780	3.520	3.220	3.020	2.840
	2.000	3.680	3.420	3.120	2.920	2.740
	2.200	3.580	3.340	3.060	2.820	2.660
	2.400	3.520	3.260	2.980	2.740	2.580
2.600	3.440	3.200	2.900	2.680	2.500	

REV#	DESCRIPTION	DATE

## SPAN TABLES

SCALE	1:2 @ A3
NAME	DATE
DRAWN	T.S 12/2013
CHECKED	M.C 00/2013



DRAWING No.

311.3.8

SLIDING DOOR

00  
10  
20  
30  
40  
50  
60  
70  
80  
90  
100

COPYRIGHT © 2011 MCKECHNIE ALUMINIUM SOLUTIONS LIMITED.  
PLEASE CHECK THAT ALL DETAILS ARE UP TO DATE BEFORE  
PROCEEDING. IF IN DOUBT ASK.

SECTION(S):  
35804 + 35830 + 36000

DESCRIPTION:  
STACKER DOOR + LARGE TEE COUPLER + WINDOW FR.

DATA:  
MOMENT OF INERTIA - 3287980 mm<sup>4</sup>

DEFLECTION MAX:  
15mm

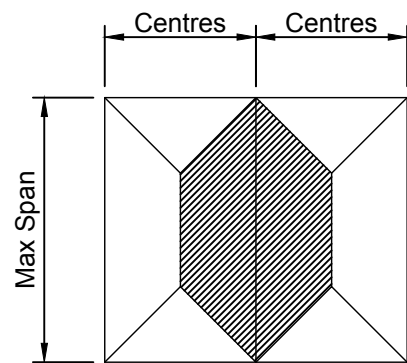
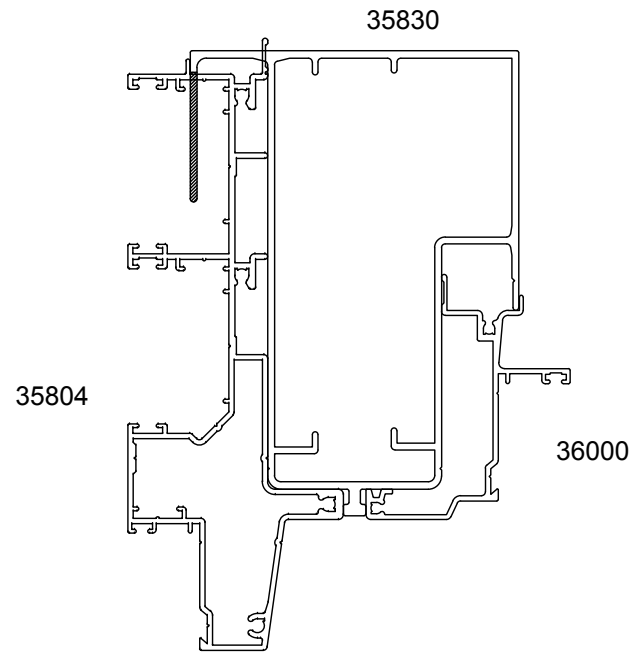

MULLION DATA - Mullion spacing and span calculations are to the current NZS 4211:2008  
Tables shall be used only where no Specific Design wind pressures are specified by the designers. The data provided is given for guidance only and the manufacturer takes no responsibility for incorrect interpretation. It is recommended that a qualified designer be consulted before fabrication.  
SPAN (m) - ULTIMATE (UWP) - SERVICEABILITY (SWP)  
SPAN / DEFLECTION (SPAN / DEF) = RESIDENTIAL 200 min

WIND ZONE :	LOW	MEDIUM	HIGH	VERY HIGH	EXTRA HIGH	
SPAN / DEF. :	200	200	200	200	200	
MULLION LOAD SPACING (m)	0.600	5.400	5.020	4.600	4.320	4.100
	0.800	5.020	4.680	4.280	4.020	3.820
	1.000	4.740	4.420	4.040	3.800	3.620
	1.200	4.540	4.220	3.860	3.620	3.460
	1.400	4.360	4.060	3.720	3.480	3.320
	1.600	4.220	3.920	3.600	3.380	3.220
	1.800	4.100	3.820	3.480	3.280	3.120
	2.000	4.000	3.720	3.400	3.180	3.040
	2.200	3.900	3.620	3.320	3.120	2.960
	2.400	3.820	3.540	3.240	3.040	2.880
2.600	3.740	3.480	3.180	2.980	2.800	

SECTION(S):  
35805 + 36185 + 36000

DESCRIPTION:  
BIPASS SLIDER + MEDIUM TEE COUPLER + WINDOW FRAME

DATA:  
MOMENT OF INERTIA - 1621745 mm<sup>4</sup>

DEFLECTION MAX:  
15mm

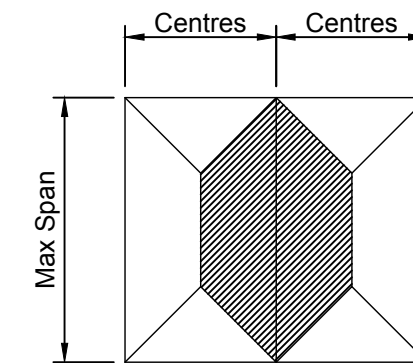
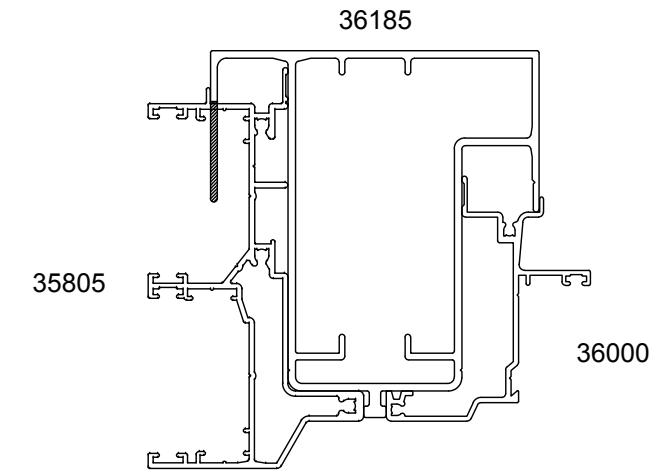

MULLION DATA - Mullion spacing and span calculations are to the current NZS 4211:2008  
Tables shall be used only where no Specific Design wind pressures are specified by the designers. The data provided is given for guidance only and the manufacturer takes no responsibility for incorrect interpretation. It is recommended that a qualified designer be consulted before fabrication.  
SPAN (m) - ULTIMATE (UWP) - SERVICEABILITY (SWP)  
SPAN / DEFLECTION (SPAN / DEF) = RESIDENTIAL 200 min

WIND ZONE :	LOW	MEDIUM	HIGH	VERY HIGH	EXTRA HIGH	
SPAN / DEF. :	200	200	200	200	200	
MULLION LOAD SPACING (m)	0.600	4.520	4.200	3.840	3.620	3.440
	0.800	4.200	3.920	3.580	3.360	3.200
	1.000	3.980	3.700	3.380	3.180	3.020
	1.200	3.800	3.540	3.240	3.040	2.860
	1.400	3.660	3.400	3.120	2.900	2.720
	1.600	3.540	3.280	3.000	2.760	2.600
	1.800	3.440	3.200	2.900	2.660	2.500
	2.000	3.340	3.120	2.800	2.580	2.420
	2.200	3.260	3.040	2.720	2.500	2.340
	2.400	3.200	2.960	2.640	2.420	2.260
2.600	3.140	2.880	2.560	2.360	2.200	

REV#	DESCRIPTION	DATE

## SPAN TABLES

SCALE	1:1 @ A3
NAME	
DATE	
DRAWN	T.S
CHECKED	M.C



DRAWING No.

311.3.9

SLIDING DOOR

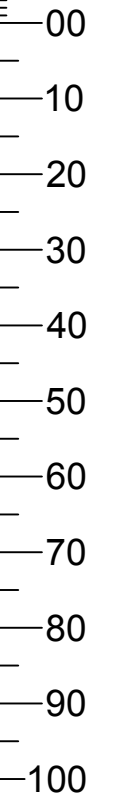

COPYRIGHT © 2011 MCKECHNIE ALUMINIUM SOLUTIONS LIMITED.  
PLEASE CHECK THAT ALL DETAILS ARE UP TO DATE BEFORE  
PROCEEDING. IF IN DOUBT ASK.

SECTION(S):  
35805 + 35830 + 36000

DESCRIPTION:  
BIPASS SLIDER + LARGE TEE COUPLER  
+ WINDOW FR.

DATA:  
MOMENT OF INERTIA - 2324206 mm<sup>4</sup>

DEFLECTION MAX:  
15mm

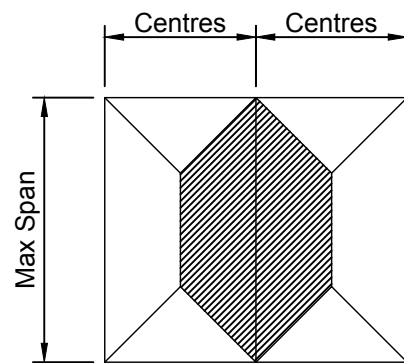
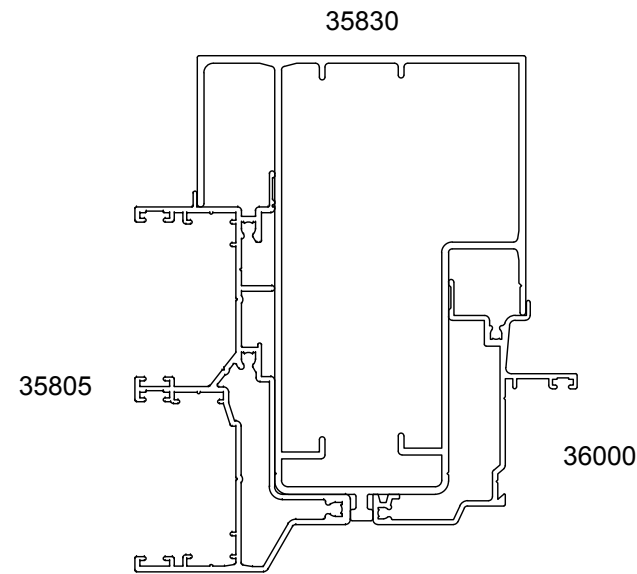

MULLION DATA - Mullion spacing and span calculations are to the current NZS 4211:2008  
Tables shall be used only where no Specific Design wind pressures are specified by the designers. The data provided is given for guidance only and the manufacturer takes no responsibility for incorrect interpretation. It is recommended that a qualified designer be consulted before fabrication.  
SPAN (m) - ULTIMATE (UWP) - SERVICEABILITY (SWP)  
SPAN / DEFLECTION (SPAN / DEF) = RESIDENTIAL 200 min

WIND ZONE :	LOW	MEDIUM	HIGH	VERY HIGH	EXTRA HIGH
SPAN / DEF. :	200	200	200	200	200
MULLION LOAD SPACING (m)	0.600	4.940	4.600	4.220	3.960
	0.800	4.600	4.280	3.920	3.680
	1.000	4.360	4.040	3.700	3.480
	1.200	4.160	3.860	3.540	3.320
	1.400	4.000	3.720	3.400	3.200
	1.600	3.860	3.600	3.300	3.100
	1.800	3.760	3.500	3.200	3.000
	2.000	3.660	3.400	3.120	2.900
	2.200	3.580	3.320	3.040	2.800
	2.400	3.500	3.260	2.960	2.720
2.600	3.420	3.180	2.900	2.660	

SECTION(S):  
35810 + 35814 + 30x3 STEEL

DESCRIPTION:  
STILE + INTERLOCKING STILE + STEEL

DATA:  
MOMENT OF INERTIA - 282920 mm<sup>4</sup>

DEFLECTION MAX:  
15mm

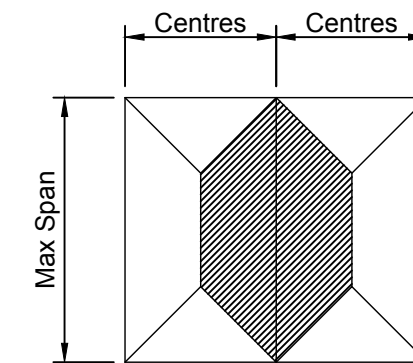
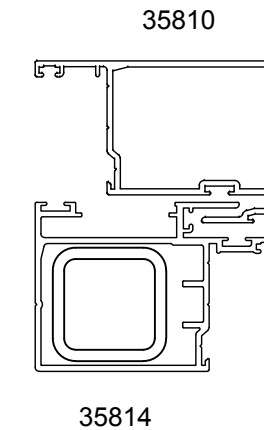

MULLION DATA - Mullion spacing and span calculations are to the current NZS 4211:2008  
Tables shall be used only where no Specific Design wind pressures are specified by the designers. The data provided is given for guidance only and the manufacturer takes no responsibility for incorrect interpretation. It is recommended that a qualified designer be consulted before fabrication.  
SPAN (m) - ULTIMATE (UWP) - SERVICEABILITY (SWP)  
SPAN / DEFLECTION (SPAN / DEF) = RESIDENTIAL 200 min

WIND ZONE :	LOW	MEDIUM	HIGH	VERY HIGH	EXTRA HIGH
SPAN / DEF. :	200	200	200	200	200
MULLION LOAD SPACING (m)	0.600	2.900	2.620	2.340	2.140
	0.800	2.620	2.380	2.120	1.940
	1.000	2.440	2.220	1.960	1.800
	1.200	2.300	2.080	1.860	1.700
	1.400	2.180	1.980	1.760	1.620
	1.600	2.080	1.900	1.680	1.540
	1.800	2.000	1.820	1.620	1.480
	2.000	1.940	1.760	1.560	1.440
	2.200	1.880	1.700	1.520	1.380
	2.400	1.820	1.660	1.460	1.340
2.600	1.780	1.600	1.420	1.320	

REV#	DESCRIPTION	DATE

## SPAN TABLES

SCALE	1:1 @ A3
NAME	
DATE	
DRAWN	T.S
CHECKED	M.C



DRAWING No.

311.3.10

SLIDING DOOR

00  
10  
20  
30  
40  
50  
60  
70  
80  
90  
100

COPYRIGHT © 2011 MCKECHNIE ALUMINIUM SOLUTIONS LIMITED.  
PLEASE CHECK THAT ALL DETAILS ARE UP TO DATE BEFORE  
PROCEEDING. IF IN DOUBT ASK  
AS ORIGINAL SIZE

SECTION(S):  
35810 + 35806 + 50x25x3 STEEL RHS

DESCRIPTION:  
STILE + INTERLOCKING MILLION + STEEL

DATA:  
MOMENT OF INERTIA - 659384 mm<sup>4</sup>

DEFLECTION MAX:  
15mm

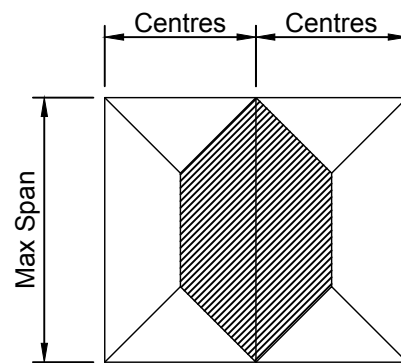
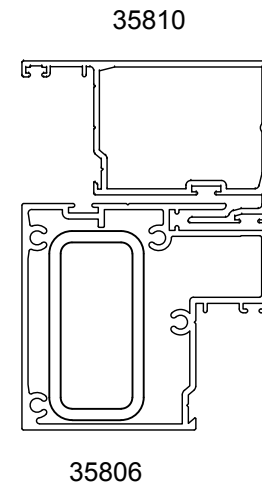

MULLION DATA - Mullion spacing and span calculations are to the current NZS 4211:2008  
Tables shall be used only where no Specific Design wind pressures are specified by the designers. The data provided is given for guidance only and the manufacturer takes no responsibility for incorrect interpretation. It is recommended that a qualified designer be consulted before fabrication.  
SPAN (m) - ULTIMATE (UWP) - SERVICEABILITY (SWP)  
SPAN / DEFLECTION (SPAN / DEF) = RESIDENTIAL 200 min

WIND ZONE :	LOW	MEDIUM	HIGH	VERY HIGH	EXTRA HIGH	
SPAN / DEF. :	200	200	200	200	200	
MULLION LOAD SPACING (m)	0.600	3.600	3.360	3.080	2.840	2.660
	0.800	3.360	3.120	2.820	2.580	2.420
	1.000	3.180	2.940	2.620	2.400	2.240
	1.200	3.040	2.760	2.460	2.260	2.120
	1.400	2.900	2.620	2.340	2.140	2.000
	1.600	2.760	2.520	2.240	2.040	1.920
	1.800	2.660	2.420	2.140	1.980	1.840
	2.000	2.560	2.340	2.080	1.900	1.780
	2.200	2.480	2.260	2.000	1.840	1.720
	2.400	2.420	2.200	1.940	1.780	1.680
2.600	2.360	2.140	1.900	1.740	1.640	

SECTION(S):  
35810 + 35815 + 2 of 40x6 STEEL

DESCRIPTION:  
STILE + HEAVY INTERLOCKING STILE + STEEL

DATA:  
MOMENT OF INERTIA - 915138 mm<sup>4</sup>

DEFLECTION MAX:  
15mm

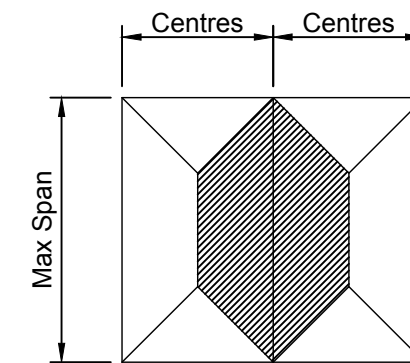
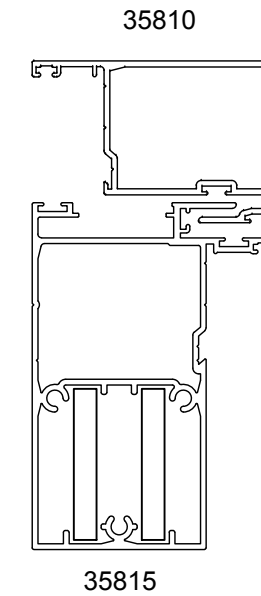

MULLION DATA - Mullion spacing and span calculations are to the current NZS 4211:2008  
Tables shall be used only where no Specific Design wind pressures are specified by the designers. The data provided is given for guidance only and the manufacturer takes no responsibility for incorrect interpretation. It is recommended that a qualified designer be consulted before fabrication.  
SPAN (m) - ULTIMATE (UWP) - SERVICEABILITY (SWP)  
SPAN / DEFLECTION (SPAN / DEF) = RESIDENTIAL 200 min

WIND ZONE :	LOW	MEDIUM	HIGH	VERY HIGH	EXTRA HIGH	
SPAN / DEF. :	200	200	200	200	200	
MULLION LOAD SPACING (m)	0.600	3.920	3.640	3.340	3.120	2.980
	0.800	3.640	3.400	3.100	2.880	2.700
	1.000	3.440	3.200	2.920	2.680	2.520
	1.200	3.300	3.060	2.740	2.520	2.360
	1.400	3.160	2.940	2.600	2.400	2.240
	1.600	3.060	2.800	2.480	2.280	2.140
	1.800	2.960	2.700	2.400	2.200	2.060
	2.000	2.860	2.600	2.320	2.120	2.000
	2.200	2.780	2.520	2.240	2.060	1.920
	2.400	2.700	2.440	2.180	2.000	1.880
2.600	2.600	2.380	2.120	1.940	1.820	

REV#	DESCRIPTION	DATE

### SPAN TABLES

SCALE	1:2 @ A3
NAME	
DATE	
DRAWN	T.S 12/2013
CHECKED	M.C 00/2013



DRAWING No.

311.3.11

SLIDING DOOR

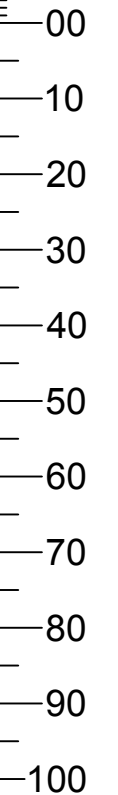

COPYRIGHT © 2011 MCKECHNIE ALUMINIUM SOLUTIONS LIMITED.  
PLEASE CHECK THAT ALL DETAILS ARE UP TO DATE BEFORE  
PROCEEDING. IF IN DOUBT ASK.

SECTION(S):  
35813 + 2 of 40x6 STEEL

DESCRIPTION:  
4PJ MALE + STEEL

DATA:  
MOMENT OF INERTIA - 725741 mm<sup>4</sup>

DEFLECTION MAX:  
15mm

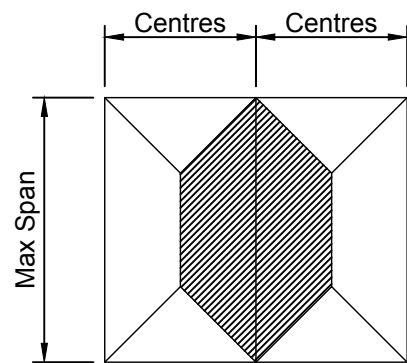
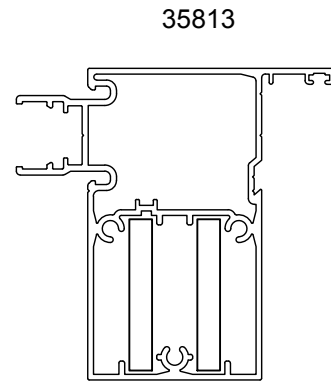

SECTION(S):  
35808 + 100x12 STEEL

DESCRIPTION:  
OVER LIGHT TRANSOM / 3PJ WITH STEEL

DATA:  
MOMENT OF INERTIA - 3903452 mm<sup>4</sup>

DEFLECTION MAX:  
15mm

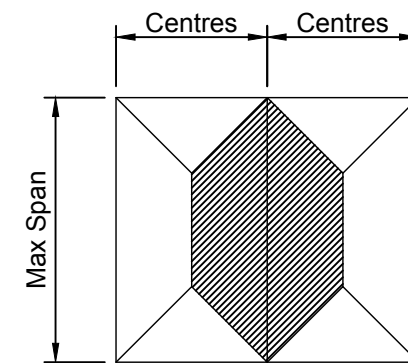
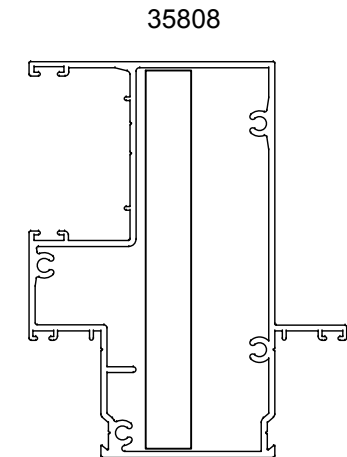

MULLION DATA - Mullion spacing and span calculations are to the current NZS 4211:2008  
Tables shall be used only where no Specific Design wind pressures are specified by the designers. The data provided is given for guidance only and the manufacturer takes no responsibility for incorrect interpretation. It is recommended that a qualified designer be consulted before fabrication.  
SPAN (m) - ULTIMATE (UWP) - SERVICEABILITY (SWP)  
SPAN / DEFLECTION (SPAN / DEF) = RESIDENTIAL 200 min

MULLION DATA - Mullion spacing and span calculations are to the current NZS 4211:2008  
Tables shall be used only where no Specific Design wind pressures are specified by the designers. The data provided is given for guidance only and the manufacturer takes no responsibility for incorrect interpretation. It is recommended that a qualified designer be consulted before fabrication.  
SPAN (m) - ULTIMATE (UWP) - SERVICEABILITY (SWP)  
SPAN / DEFLECTION (SPAN / DEF) = RESIDENTIAL 200 min

WIND ZONE :	LOW	MEDIUM	HIGH	VERY HIGH	EXTRA HIGH	
SPAN / DEF. :	200	200	200	200	200	
MULLION LOAD SPACING (m)	0.600	3.700	3.440	3.140	2.940	2.760
	0.800	3.440	3.200	2.900	2.660	2.500
	1.000	3.260	3.020	2.700	2.480	2.320
	1.200	3.100	2.860	2.540	2.340	2.180
	1.400	2.980	2.720	2.400	2.220	2.080
	1.600	2.860	2.600	2.300	2.120	1.980
	1.800	2.740	2.500	2.220	2.040	1.900
	2.000	2.660	2.400	2.140	1.960	1.840
	2.200	2.560	2.340	2.080	1.900	1.780
	2.400	2.500	2.260	2.020	1.840	1.740
2.600	2.420	2.200	1.960	1.800	1.680	

WIND ZONE :	LOW	MEDIUM	HIGH	VERY HIGH	EXTRA HIGH	
SPAN / DEF. :	200	200	200	200	200	
MULLION LOAD SPACING (m)	0.600	5.640	5.240	4.800	4.500	4.280
	0.800	5.240	4.880	4.460	4.180	4.000
	1.000	4.960	4.620	4.220	3.960	3.780
	1.200	4.740	4.400	4.040	3.780	3.600
	1.400	4.560	4.240	3.880	3.640	3.460
	1.600	4.400	4.100	3.760	3.520	3.360
	1.800	4.280	3.980	3.640	3.420	3.260
	2.000	4.160	3.880	3.540	3.320	3.180
	2.200	4.060	3.780	3.460	3.240	3.100
	2.400	3.980	3.700	3.380	3.180	3.020
2.600	3.900	3.620	3.320	3.120	2.960	

REV#	DESCRIPTION	DATE

## SPAN TABLES

SCALE	1:1 @ A3
NAME	DATE
DRAWN	T.S 12/2013
CHECKED	M.C 00/2013



DRAWING No.

311.3.12

SLIDING DOOR

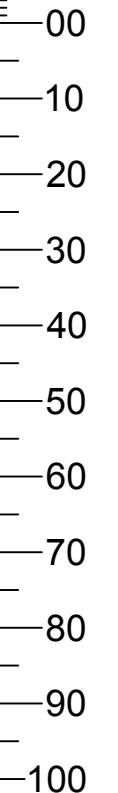

COPYRIGHT © 2011 MCKECHNIE ALUMINIUM SOLUTIONS LIMITED.  
PLEASE CHECK THAT ALL DETAILS ARE UP TO DATE BEFORE  
PROCEEDING. IF IN DOUBT ASK.

SECTION(S):  
36631 + 36633 + 35806

DESCRIPTION:  
STANDARD INTERLOCKER MULLION + STILE

DATA:  
MOMENT OF INERTIA - 351571 mm<sup>4</sup>

DEFLECTION MAX:  
15mm

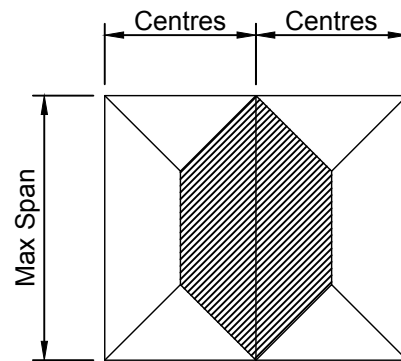
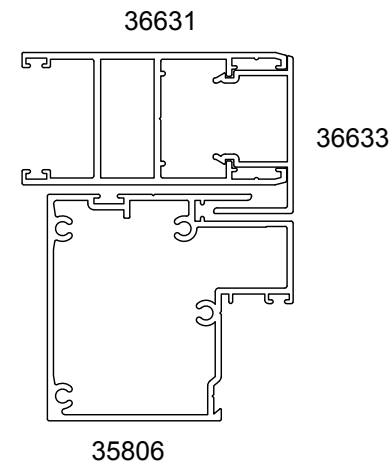

MULLION DATA - Mullion spacing and span calculations are to the current NZS 4211:2008  
Tables shall be used only where no Specific Design wind pressures are specified by the designers. The data provided is given for guidance only and the manufacturer takes no responsibility for incorrect interpretation. It is recommended that a qualified designer be consulted before fabrication.  
SPAN (m) - ULTIMATE (UWP) - SERVICEABILITY (SWP)  
SPAN / DEFLECTION (SPAN / DEF) = RESIDENTIAL 200 min

WIND ZONE :	LOW	MEDIUM	HIGH	VERY HIGH	EXTRA HIGH
SPAN / DEF. :	200	200	200	200	200
MULLION LOAD SPACING (m)	0.600	3.080	2.820	2.520	2.300
	0.800	2.820	2.560	2.280	2.100
	1.000	2.620	2.380	2.120	1.940
	1.200	2.460	2.240	2.000	1.820
	1.400	2.340	2.120	1.900	1.740
	1.600	2.240	2.040	1.800	1.660
	1.800	2.160	1.960	1.740	1.600
	2.000	2.080	1.880	1.680	1.540
	2.200	2.020	1.820	1.620	1.500
	2.400	1.960	1.780	1.580	1.440
2.600	1.900	1.740	1.540	1.420	

SECTION(S):  
36631 + 36633 + 35807

DESCRIPTION:  
STANDARD MULLION + HEAVY DUTY INTERLOCKER STILE

DATA:  
MOMENT OF INERTIA - 996050 mm<sup>4</sup>

DEFLECTION MAX:  
15mm

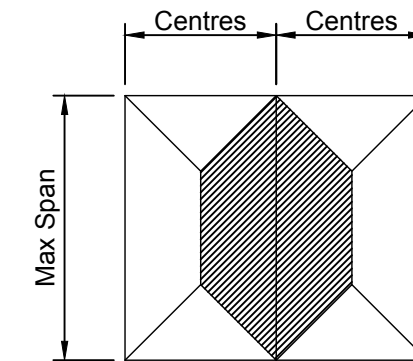
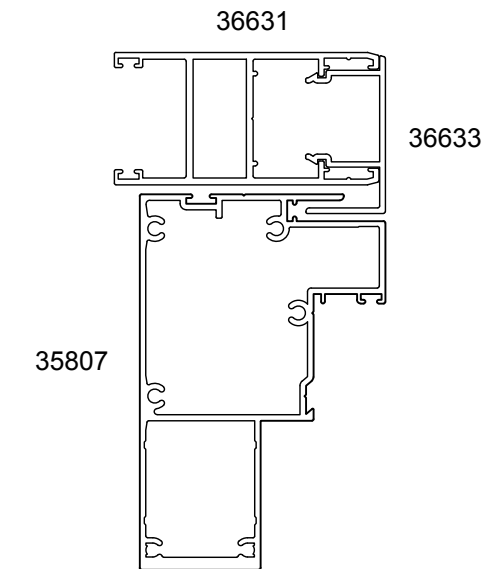

MULLION DATA - Mullion spacing and span calculations are to the current NZS 4211:2008  
Tables shall be used only where no Specific Design wind pressures are specified by the designers. The data provided is given for guidance only and the manufacturer takes no responsibility for incorrect interpretation. It is recommended that a qualified designer be consulted before fabrication.  
SPAN (m) - ULTIMATE (UWP) - SERVICEABILITY (SWP)  
SPAN / DEFLECTION (SPAN / DEF) = RESIDENTIAL 200 min

WIND ZONE :	LOW	MEDIUM	HIGH	VERY HIGH	EXTRA HIGH
SPAN / DEF. :	200	200	200	200	200
MULLION LOAD SPACING (m)	0.600	4.000	3.720	3.400	3.200
	0.800	3.720	3.460	3.160	2.960
	1.000	3.520	3.280	3.000	2.760
	1.200	3.360	3.120	2.820	2.600
	1.400	3.240	3.000	2.680	2.460
	1.600	3.120	2.880	2.560	2.360
	1.800	3.040	2.780	2.460	2.260
	2.000	2.940	2.680	2.380	2.180
	2.200	2.860	2.600	2.300	2.120
	2.400	2.780	2.520	2.240	2.060
2.600	2.700	2.460	2.180	2.000	

REV#	DESCRIPTION	DATE

## SPAN TABLES

SCALE	1:1 @ A3
NAME	DATE
DRAWN	T.S 12/2013
CHECKED	M.C 00/2013



DRAWING No.

311.3.13

SLIDING DOOR

00  
10  
20  
30  
40  
50  
60  
70  
80  
90  
100

COPYRIGHT © 2011 MCKECHNIE ALUMINIUM SOLUTIONS LIMITED.  
PLEASE CHECK THAT ALL DETAILS ARE UP TO DATE BEFORE  
PROCEEDING. IF IN DOUBT ASK.



SECTION(S):  
36631 + 36632 + 36632 + 36631

DESCRIPTION:  
INTERLOCKER STILE'S

DATA:  
MOMENT OF INERTIA - 309347 mm<sup>4</sup>

DEFLECTION MAX:  
15mm

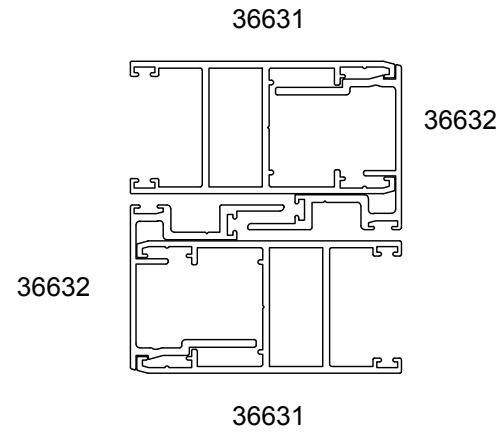

MULLION DATA - Mullion spacing and span calculations are to the current NZS 4211:2008  
Tables shall be used only where no Specific Design wind pressures are specified by the designers. The data provided is given for guidance only and the manufacturer takes no responsibility for incorrect interpretation. It is recommended that a qualified designer be consulted before fabrication.  
SPAN (m) - ULTIMATE (UWP) - SERVICEABILITY (SWP)  
SPAN / DEFLECTION (SPAN / DEF) = RESIDENTIAL 200 min

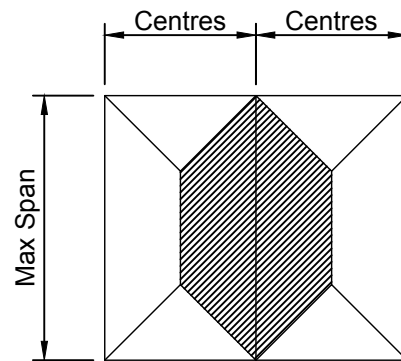

WIND ZONE :	LOW	MEDIUM	HIGH	VERY HIGH	EXTRA HIGH	
SPAN / DEF. :	200	200	200	200	200	
MULLION LOAD SPACING (m)	0.600	2.980	2.700	2.400	2.200	2.080
	0.800	2.700	2.460	2.180	2.000	1.880
	1.000	2.520	2.280	2.020	1.860	1.740
	1.200	2.360	2.140	1.900	1.760	1.640
	1.400	2.240	2.040	1.820	1.660	1.560
	1.600	2.140	1.960	1.740	1.600	1.500
	1.800	2.060	1.880	1.660	1.520	1.440
	2.000	2.000	1.800	1.600	1.480	1.380
	2.200	1.940	1.760	1.560	1.420	1.340
	2.400	1.880	1.700	1.520	1.380	1.300
2.600	1.820	1.660	1.480	1.360	1.260	

SECTION(S):  
36631 + 36012 + 36876 + 36631

DESCRIPTION:  
Mitre Panel 4PJ

DATA:  
MOMENT OF INERTIA - 560119 mm<sup>4</sup>

DEFLECTION MAX:  
15mm

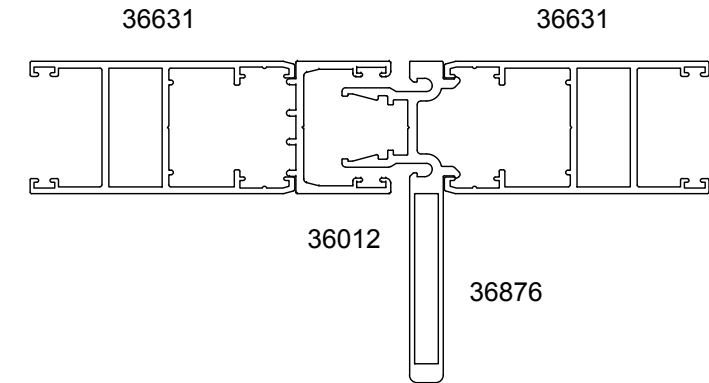

MULLION DATA - Mullion spacing and span calculations are to the current NZS 4211:2008  
Tables shall be used only where no Specific Design wind pressures are specified by the designers. The data provided is given for guidance only and the manufacturer takes no responsibility for incorrect interpretation. It is recommended that a qualified designer be consulted before fabrication.  
SPAN (m) - ULTIMATE (UWP) - SERVICEABILITY (SWP)  
SPAN / DEFLECTION (SPAN / DEF) = RESIDENTIAL 200 min

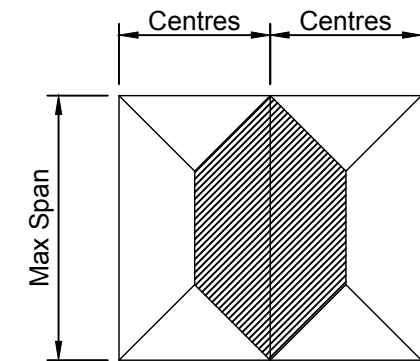

WIND ZONE :	LOW	MEDIUM	HIGH	VERY HIGH	EXTRA HIGH	
SPAN / DEF. :	200	200	200	200	200	
MULLION LOAD SPACING (m)	0.600	3.460	3.220	2.940	2.700	2.520
	0.800	3.220	3.000	2.660	2.440	2.300
	1.000	3.040	2.780	2.480	2.280	2.120
	1.200	2.880	2.620	2.320	2.140	2.000
	1.400	2.740	2.480	2.200	2.020	1.900
	1.600	2.620	2.380	2.120	1.940	1.820
	1.800	2.520	2.280	2.040	1.860	1.740
	2.000	2.440	2.200	1.960	1.800	1.680
	2.200	2.360	2.140	1.900	1.740	1.640
	2.400	2.280	2.080	1.840	1.700	1.580
2.600	2.220	2.020	1.800	1.640	1.540	

REV#	DESCRIPTION	DATE

SPAN TABLES

SCALE	N.T.S	
NAME		DATE
DRAWN	T.S	12/2013
CHECKED	M.C	00/2013



DRAWING No.

311.3.14

SLIDING DOOR

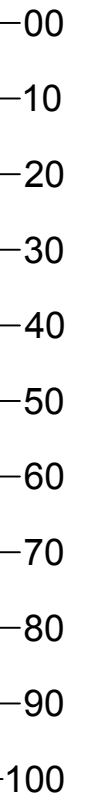

COPYRIGHT © 2011 MCKECHNIE ALUMINIUM SOLUTIONS LIMITED.  
PLEASE CHECK THAT ALL DETAILS ARE UP TO DATE BEFORE  
PROCEEDING. IF IN DOUBT ASK.

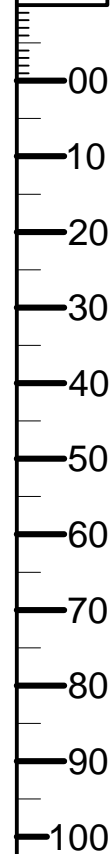

# Alpha Sliding Span Charts

## 312

REV#	DESCRIPTION	DATE
-	-	00/2013
-	-	00/2013
-	-	00/2013
-	-	00/00/2013

SPAN CHART

SCALE	NTS	
	NAME	DATE
DRAWN	ADM	05/10/17
CHECKED		



DRAWING No. 300 SERIES SP

SECTION(S):  
36854 + 35814

DESCRIPTION:  
STANDARD INTERLOCKER MULLION + STILE

DATA:  
MOMENT OF INERTIA - 280776 mm<sup>4</sup>

DEFLECTION MAX:  
15mm

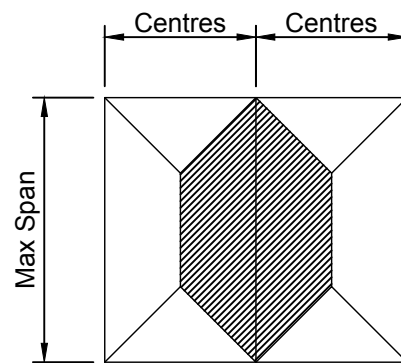
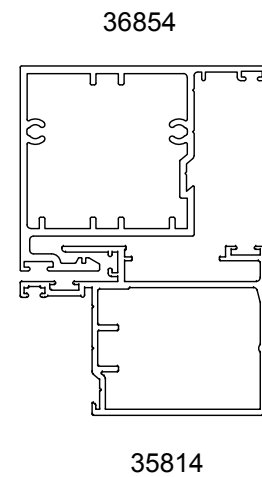

MULLION DATA - Mullion spacing and span calculations are to the current NZS 4211:2008  
Tables shall be used only where no Specific Design wind pressures are specified by the designers. The data provided is given for guidance only and the manufacturer takes no responsibility for incorrect interpretation. It is recommended that a qualified designer be consulted before fabrication.  
SPAN (m) - ULTIMATE (UWP) - SERVICEABILITY (SWP)  
SPAN / DEFLECTION (SPAN / DEF) = RESIDENTIAL 200 min

WIND ZONE :	LOW	MEDIUM	HIGH	VERY HIGH	EXTRA HIGH	
SPAN / DEF. :	200	200	200	200	200	
MULLION LOAD SPACING (m)	0.600	2.880	2.620	2.320	2.140	2.000
	0.800	2.620	2.380	2.120	1.940	1.820
	1.000	2.440	2.200	1.960	1.800	1.680
	1.200	2.280	2.080	1.840	1.700	1.580
	1.400	2.180	1.980	1.760	1.600	1.500
	1.600	2.080	1.880	1.680	1.540	1.440
	1.800	2.000	1.820	1.620	1.480	1.380
	2.000	1.920	1.760	1.560	1.420	1.340
	2.200	1.860	1.700	1.500	1.380	1.300
	2.400	1.820	1.640	1.460	1.340	1.260
2.600	1.760	1.600	1.420	1.300	1.220	

SECTION(S):  
36854 + 35815

DESCRIPTION:  
HEAVY REVERSE INTERLOCKER STILES

DATA:  
MOMENT OF INERTIA - 826117 mm<sup>4</sup>

DEFLECTION MAX:  
15mm

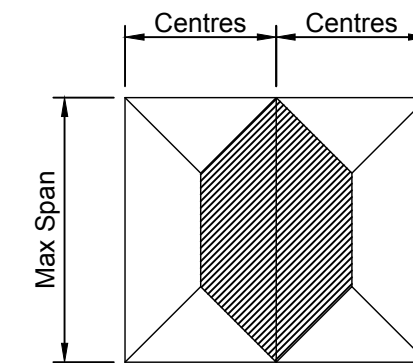
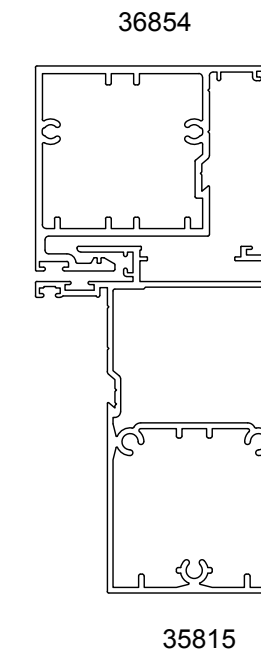

MULLION DATA - Mullion spacing and span calculations are to the current NZS 4211:2008  
Tables shall be used only where no Specific Design wind pressures are specified by the designers. The data provided is given for guidance only and the manufacturer takes no responsibility for incorrect interpretation. It is recommended that a qualified designer be consulted before fabrication.  
SPAN (m) - ULTIMATE (UWP) - SERVICEABILITY (SWP)  
SPAN / DEFLECTION (SPAN / DEF) = RESIDENTIAL 200 min

WIND ZONE :	LOW	MEDIUM	HIGH	VERY HIGH	EXTRA HIGH	
SPAN / DEF. :	200	200	200	200	200	
MULLION LOAD SPACING (m)	0.600	3.820	3.560	3.240	3.040	2.880
	0.800	3.560	3.300	3.020	2.780	2.620
	1.000	3.360	3.120	2.820	2.580	2.420
	1.200	3.200	2.980	2.640	2.440	2.280
	1.400	3.080	2.840	2.520	2.320	2.160
	1.600	2.980	2.700	2.400	2.220	2.080
	1.800	2.860	2.600	2.320	2.120	2.000
	2.000	2.760	2.520	2.240	2.060	1.920
	2.200	2.680	2.440	2.160	1.980	1.860
	2.400	2.600	2.360	2.100	1.920	1.800
2.600	2.540	2.300	2.040	1.880	1.760	

REV#	DESCRIPTION	DATE
A	New Span Data Added	01/10/15

### SPAN TABLES

SCALE	1:2 @ A3
NAME	DATE
DRAWN	T.S 12/2013
CHECKED	M.C 00/2013



DRAWING No.  
**312.3.2**

ALPHA SLIDING DOOR

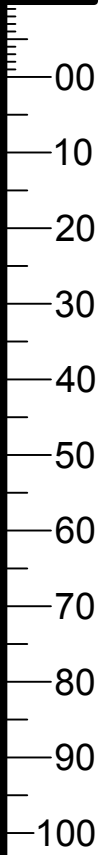

COPYRIGHT © 2011 MCKECHNIE ALUMINIUM SOLUTIONS LIMITED.  
PLEASE CHECK THAT ALL DETAILS ARE UP TO DATE BEFORE  
PROCEEDING. IF IN DOUBT ASK.

SECTION(S):  
37038 + 36854 + 35815

DESCRIPTION:  
STANDARD MULLION + HEAVY DUTY  
INTERLOCKER STILE

DATA:  
MOMENT OF INERTIA - 1295085 mm<sup>4</sup>

DEFLECTION MAX:  
15mm

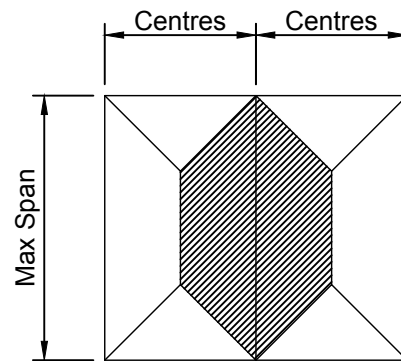
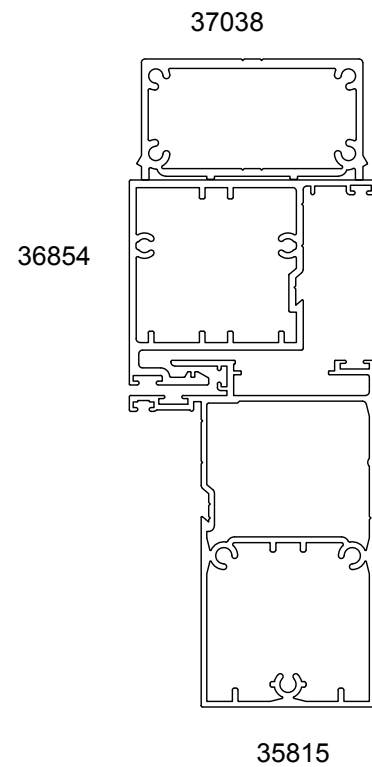

MULLION DATA - Mullion spacing and span calculations are to the current NZS 4211:2008  
Tables shall be used only where no Specific Design wind pressures are specified by the designers. The data provided is given for guidance only and the manufacturer takes no responsibility for incorrect interpretation. It is recommended that a qualified designer be consulted before fabrication.  
SPAN (m) - ULTIMATE (UWP) - SERVICEABILITY (SWP)  
SPAN / DEFLECTION (SPAN / DEF) = RESIDENTIAL 200 min

WIND ZONE :	LOW	MEDIUM	HIGH	VERY HIGH	EXTRA HIGH
SPAN / DEF. :	200	200	200	200	200
MULLION LOAD SPACING (m)	0.600	4.280	3.980	3.640	3.420
	0.800	3.980	3.700	3.380	3.180
	1.000	3.760	3.500	3.200	3.000
	1.200	3.600	3.340	3.060	2.820
	1.400	3.460	3.220	2.920	2.660
	1.600	3.340	3.100	2.800	2.520
	1.800	3.240	3.020	2.680	2.400
	2.000	3.160	2.920	2.600	2.320
	2.200	3.080	2.840	2.520	2.240
	2.400	3.020	2.760	2.440	2.160
2.600	2.940	2.680	2.380	2.100	
2.800	2.880	2.600	2.300	2.040	

SECTION(S):  
36855 + 35814

DESCRIPTION:  
HEAVY REVERSE INTERLOCKER STILES

DATA:  
MOMENT OF INERTIA - 189888 mm<sup>4</sup>

DEFLECTION MAX:  
15mm

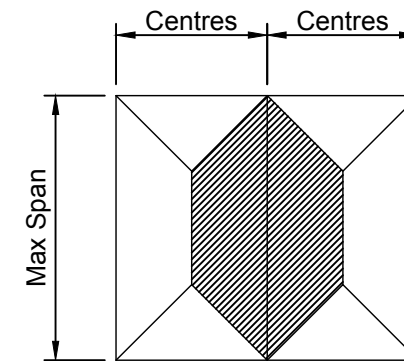
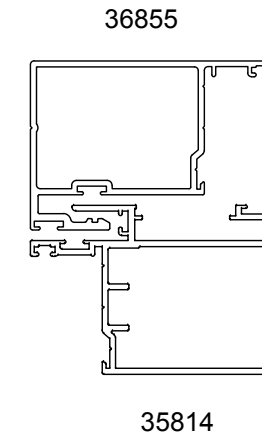

MULLION DATA - Mullion spacing and span calculations are to the current NZS 4211:2008  
Tables shall be used only where no Specific Design wind pressures are specified by the designers. The data provided is given for guidance only and the manufacturer takes no responsibility for incorrect interpretation. It is recommended that a qualified designer be consulted before fabrication.  
SPAN (m) - ULTIMATE (UWP) - SERVICEABILITY (SWP)  
SPAN / DEFLECTION (SPAN / DEF) = RESIDENTIAL 200 min

WIND ZONE :	LOW	MEDIUM	HIGH	VERY HIGH	EXTRA HIGH
SPAN / DEF. :	200	200	200	200	200
MULLION LOAD SPACING (m)	0.600	2.540	2.300	2.040	1.880
	0.800	2.300	2.080	1.860	1.700
	1.000	2.140	1.940	1.720	1.580
	1.200	2.000	1.820	1.620	1.480
	1.400	1.900	1.740	1.540	1.400
	1.600	1.820	1.660	1.480	1.320
	1.800	1.760	1.600	1.420	1.260
	2.000	1.700	1.540	1.360	1.200
	2.200	1.640	1.480	1.320	1.140
	2.400	1.600	1.440	1.280	1.100
2.600	1.540	1.400	1.240	1.080	

REV#	DESCRIPTION	DATE
A	New Span Data Added	01/10/15

## SPAN TABLES

SCALE	1:2 @ A3
NAME	
DRAWN	T.S
CHECKED	M.C



DRAWING No.

312.3.3

ALPHA SLIDING DOOR

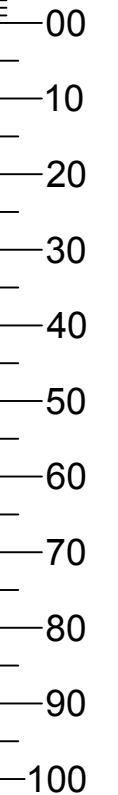

COPYRIGHT © 2011 MCKECHNIE ALUMINIUM SOLUTIONS LIMITED.  
PLEASE CHECK THAT ALL DETAILS ARE UP TO DATE BEFORE  
PROCEEDING. IF IN DOUBT ASK.

SECTION(S):  
36855 + 35815

DESCRIPTION:  
STANDARD MULLION + HEAVY DUTY  
INTERLOCKER STILE

DATA:  
MOMENT OF INERTIA - 735227 mm<sup>4</sup>

DEFLECTION MAX:  
15mm

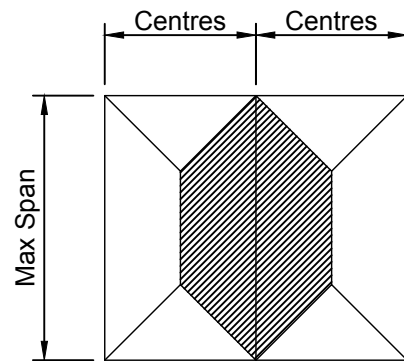
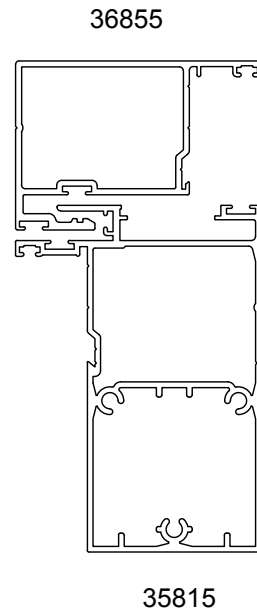

MULLION DATA - Mullion spacing and span calculations are to the current NZS 4211:2008  
Tables shall be used only where no Specific Design wind pressures are specified by the designers. The data provided is given for guidance only and the manufacturer takes no responsibility for incorrect interpretation. It is recommended that a qualified designer be consulted before fabrication.  
SPAN (m) - ULTIMATE (UWP) - SERVICEABILITY (SWP)  
SPAN / DEFLECTION (SPAN / DEF) = RESIDENTIAL 200 min

WIND ZONE :	LOW	MEDIUM	HIGH	VERY HIGH	EXTRA HIGH	
SPAN / DEF. :	200	200	200	200	200	
MULLION LOAD SPACING (m)	0.600	3.700	3.440	3.160	2.960	2.760
	0.800	3.440	3.200	2.920	2.680	2.520
	1.000	3.260	3.040	2.700	2.480	2.340
	1.200	3.120	2.860	2.540	2.340	2.200
	1.400	3.000	2.720	2.420	2.220	2.080
	1.600	2.860	2.600	2.320	2.120	2.000
	1.800	2.760	2.500	2.220	2.040	1.920
	2.000	2.660	2.420	2.140	1.980	1.840
	2.200	2.580	2.340	2.080	1.920	1.800
	2.400	2.500	2.280	2.020	1.860	1.740
2.600	2.440	2.220	1.960	1.800	1.700	

SECTION(S):  
37038 + 36855 + 35815

DESCRIPTION:  
HEAVY REVERSE INTERLOCKER STILES

DATA:  
MOMENT OF INERTIA - 1076924 mm<sup>4</sup>

DEFLECTION MAX:  
15mm

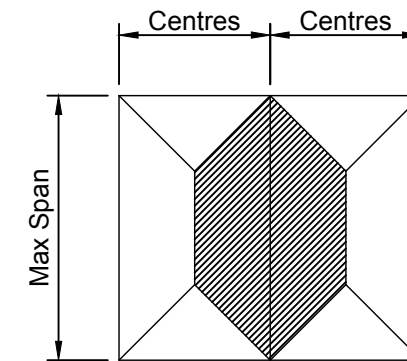
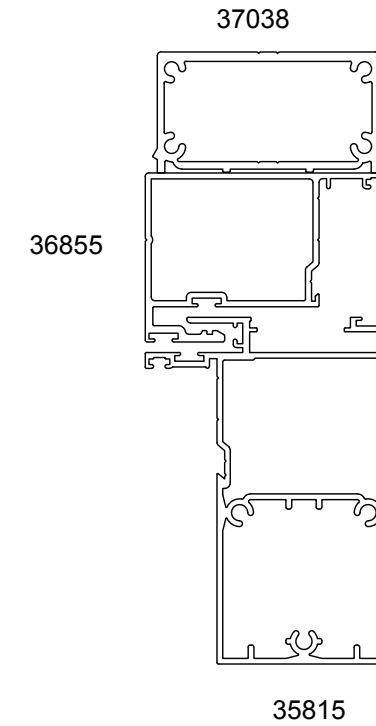

MULLION DATA - Mullion spacing and span calculations are to the current NZS 4211:2008  
Tables shall be used only where no Specific Design wind pressures are specified by the designers. The data provided is given for guidance only and the manufacturer takes no responsibility for incorrect interpretation. It is recommended that a qualified designer be consulted before fabrication.  
SPAN (m) - ULTIMATE (UWP) - SERVICEABILITY (SWP)  
SPAN / DEFLECTION (SPAN / DEF) = RESIDENTIAL 200 min

WIND ZONE :	LOW	MEDIUM	HIGH	VERY HIGH	EXTRA HIGH	
SPAN / DEF. :	200	200	200	200	200	
MULLION LOAD SPACING (m)	0.600	4.080	3.800	3.480	3.260	3.100
	0.800	3.800	3.540	3.240	3.040	2.860
	1.000	3.580	3.340	3.060	2.820	2.660
	1.200	3.420	3.200	2.900	2.660	2.500
	1.400	3.300	3.060	2.740	2.520	2.360
	1.600	3.200	2.960	2.620	2.420	2.260
	1.800	3.100	2.840	2.520	2.320	2.180
	2.000	3.020	2.740	2.440	2.240	2.100
	2.200	2.940	2.660	2.360	2.180	2.040
	2.400	2.840	2.580	2.300	2.100	1.980
2.600	2.780	2.520	2.240	2.060	1.920	

REV#	DESCRIPTION	DATE

SPAN TABLES

SCALE	1:2 @ A3
NAME	
DRAWN	T.S
CHECKED	M.C



DRAWING No.

312.3.4

ALPHA SLIDING DOOR

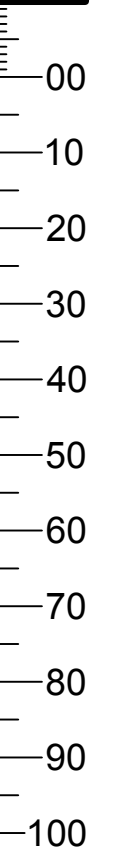

COPYRIGHT © 2011 MCKECHNIE ALUMINIUM SOLUTIONS LIMITED.  
PLEASE CHECK THAT ALL DETAILS ARE UP TO DATE BEFORE  
PROCEEDING. IF IN DOUBT ASK.

SECTION(S):  
35812 + 35813

DESCRIPTION:  
4 PANEL MEETING STILES

DATA:  
MOMENT OF INERTIA - 624029 mm<sup>4</sup>

DEFLECTION MAX:  
15mm

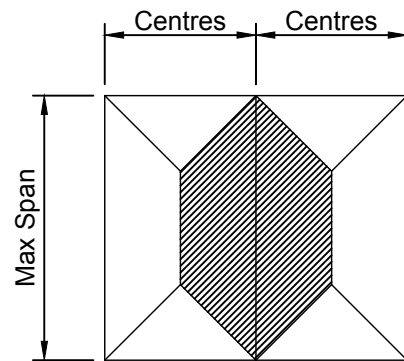
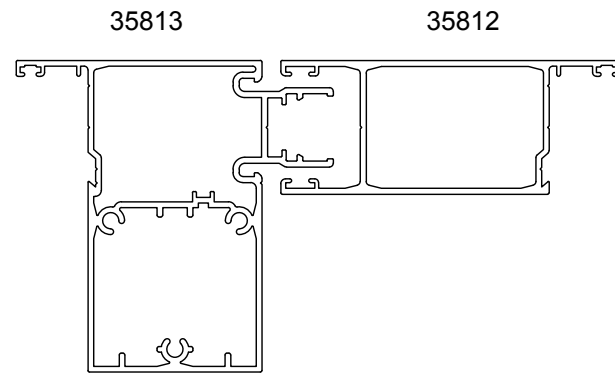

MULLION DATA - Mullion spacing and span calculations are to the current NZS 4211:2008  
Tables shall be used only where no Specific Design wind pressures are specified by the designers. The data provided is given for guidance only and the manufacturer takes no responsibility for incorrect interpretation. It is recommended that a qualified designer be consulted before fabrication.  
SPAN (m) - ULTIMATE (UWP) - SERVICEABILITY (SWP)  
SPAN / DEFLECTION (SPAN / DEF) = RESIDENTIAL 200 min

WIND ZONE :		LOW	MEDIUM	HIGH	VERY HIGH	EXTRA HIGH
SPAN / DEF. :		200	200	200	200	200
MULLION LOAD SPACING (m)	0.600	3.560	3.320	3.020	2.800	2.620
	0.800	3.320	3.080	2.760	2.540	2.380
	1.000	3.140	2.880	2.560	2.360	2.200
	1.200	3.000	2.720	2.420	2.220	2.080
	1.400	2.840	2.580	2.300	2.100	1.980
	1.600	2.720	2.460	2.200	2.020	1.880
	1.800	2.620	2.380	2.100	1.940	1.820
	2.000	2.520	2.280	2.040	1.860	1.760
	2.200	2.440	2.220	1.960	1.800	1.700
	2.400	2.380	2.160	1.920	1.760	1.640
2.600	2.300	2.100	1.860	1.700	1.600	

REV#	DESCRIPTION	DATE
A	36696 Added	19/11/15

## SPAN TABLES

SCALE	1:2 @ A3	
NAME		DATE
DRAWN	T.S	12/2013
CHECKED	M.C	00/2013

**O MEGA**  
WINDOWS + DOORS

DRAWING No.

312.3.5

ALPHA SLIDING DOOR

00  
10  
20  
30  
40  
50  
60  
70  
80  
90  
100

COPYRIGHT © 2011 MCKECHNIE ALUMINIUM SOLUTIONS LIMITED.  
PLEASE CHECK THAT ALL DETAILS ARE UP TO DATE BEFORE  
PROCEEDING. IF IN DOUBT ASK.

SECTION(S):  
36853 + 35830 + 36000

DESCRIPTION:  
SLIDING DOOR + MEDIUM TEE COUPLER  
+ WINDOW FRAME

DATA:  
MOMENT OF INERTIA - 2438774 mm<sup>4</sup>

DEFLECTION MAX:  
15mm

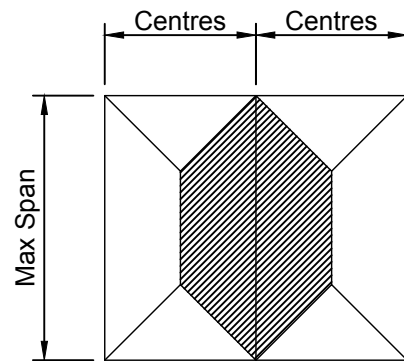
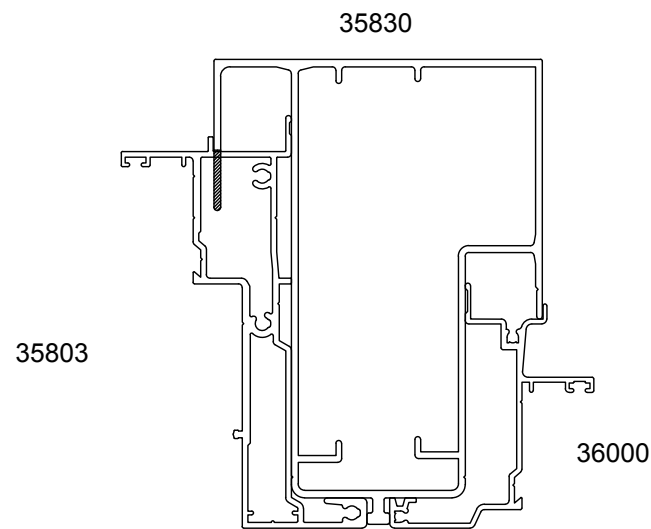

MULLION DATA - Mullion spacing and span calculations are to the current NZS 4211:2008  
Tables shall be used only where no Specific Design wind pressures are specified by the designers. The data provided is given for guidance only and the manufacturer takes no responsibility for incorrect interpretation. It is recommended that a qualified designer be consulted before fabrication.  
SPAN (m) - ULTIMATE (UWP) - SERVICEABILITY (SWP)  
SPAN / DEFLECTION (SPAN / DEF) = RESIDENTIAL 200 min

WIND ZONE :	LOW	MEDIUM	HIGH	VERY HIGH	EXTRA HIGH
SPAN / DEF. :	200	200	200	200	200
MULLION LOAD SPACING (m)	0.600	5.000	4.660	4.260	3.820
	0.800	4.660	4.340	3.960	3.540
	1.000	4.400	4.100	3.740	3.360
	1.200	4.200	3.920	3.580	3.200
	1.400	4.040	3.760	3.440	3.080
	1.600	3.920	3.640	3.340	2.980
	1.800	3.800	3.540	3.240	2.860
	2.000	3.700	3.440	3.160	2.760
	2.200	3.620	3.360	3.080	2.680
	2.400	3.540	3.300	3.020	2.600
2.600	3.460	3.220	2.940	2.540	

SECTION(S):  
36859 + 35830 + 36000

DESCRIPTION:  
SLIDING DOOR + LARGE TEE COUPLER +  
WINDOW FRAME

DATA:  
MOMENT OF INERTIA - 3397984 mm<sup>4</sup>

DEFLECTION MAX:  
15mm

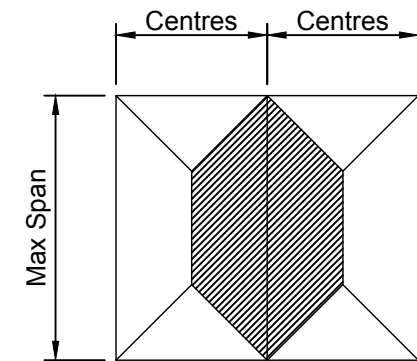
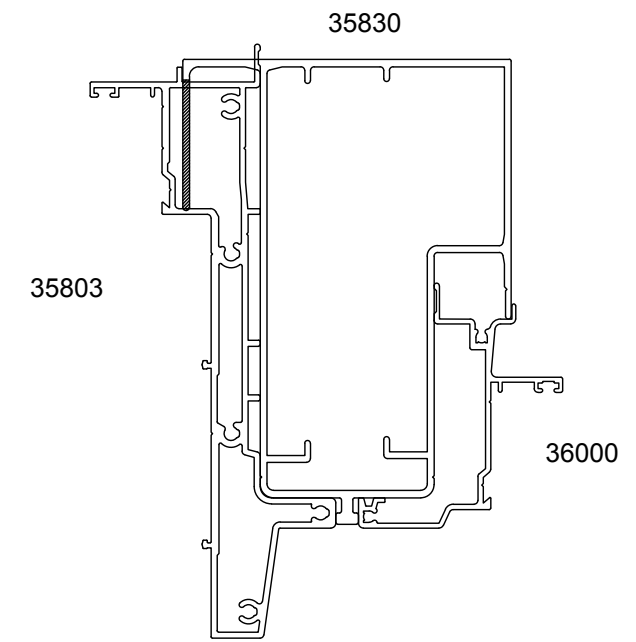

MULLION DATA - Mullion spacing and span calculations are to the current NZS 4211:2008  
Tables shall be used only where no Specific Design wind pressures are specified by the designers. The data provided is given for guidance only and the manufacturer takes no responsibility for incorrect interpretation. It is recommended that a qualified designer be consulted before fabrication.  
SPAN (m) - ULTIMATE (UWP) - SERVICEABILITY (SWP)  
SPAN / DEFLECTION (SPAN / DEF) = RESIDENTIAL 200 min

WIND ZONE :	LOW	MEDIUM	HIGH	VERY HIGH	EXTRA HIGH
SPAN / DEF. :	200	200	200	200	200
MULLION LOAD SPACING (m)	0.600	5.440	5.060	4.640	4.340
	0.800	5.060	4.720	4.300	4.040
	1.000	4.780	4.460	4.080	3.820
	1.200	4.580	4.260	3.900	3.660
	1.400	4.400	4.100	3.740	3.520
	1.600	4.260	3.960	3.620	3.400
	1.800	4.140	3.840	3.520	3.300
	2.000	4.020	3.740	3.420	3.220
	2.200	3.920	3.660	3.340	3.140
	2.400	3.840	3.580	3.280	3.080
2.600	3.760	3.500	3.200	3.000	

REV#	DESCRIPTION	DATE

SPAN TABLES

SCALE	N.T.S	
NAME		DATE
DRAWN	T.S	12/2013
CHECKED	M.C	00/2013



DRAWING No.

312.3.6

ALPHA SLIDING DOOR

00  
10  
20  
30  
40  
50  
60  
70  
80  
90  
100

COPYRIGHT © 2011 MCKECHNIE ALUMINIUM SOLUTIONS LIMITED.  
PLEASE CHECK THAT ALL DETAILS ARE UP TO DATE BEFORE  
PROCEEDING. IF IN DOUBT ASK.