

Insulated Roof & Wall Panels
Australia & New Zealand



Architectural Wall Panels (AWP)

KS1000

Installation Guide

Vertically Laid

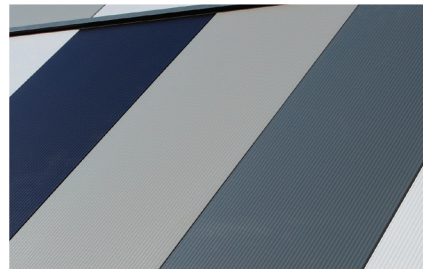

January 2020



Architectural Wall Panels KS1000 (AWP)

Vertically Laid

Components

Architectural Wall Panel



Primary / Main fastener
(Carbon Steel)

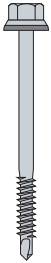

Neutral cure
gun-grade
sealant



Gun-grade sealant type
- Selleys Permasil 626 or
equivalent

Fire-rated
canister
insulation



External
corner
flashing



PIR
insulation



Continuous
ledger angle



Butyl tape sealant



Secondary /
Stitching screw



AWP
filler



Drip flashing



Low profile
fastener



Continuous
Base Support
angle



This installation guide should be read in conjunction with the 'project specific' design drawings and method statements.

Although this installation guide is deemed to be correct at the time of publication, Kingspan reserve the right to amend the information at any time in the future. Installation Guides are available for the full range of Kingspan Insulated Roof, Wall and Facade Systems.

Please call Kingspan Technical Services on:

Aus Tel: (02) 8889 3000

NZ Tel: +64 3-260 5530

Architectural Wall Panels KS1000 (AWP)

Vertically Laid

Note: Ensure steelwork is suitably lined, levelled and within tolerance.

Visually check internal liner joint to ensure panels are joined fully.

Check panel cover width module as works progress to ensure "creep" does not occur, particularly important when windows are incorporated into the elevation.

Joints need to be aligned correctly during installation to prevent the 'saw tooth' effect at the drip.

Tape sealant referred to is butyl tape sealant.

This is a generic AWP installation guide, however details may differ from project to project. Project specific construction details must be used, please contact Kingspan Technical Services for further information.

All fasteners to be carbon steel to maintain panel warranty.

Gun-grade sealant type - neutral cure gun-grade sealant.

Number of fasteners must be calculated based on project spans and wind loads.

See specific details for high humidity applications.

Contact Kingspan Technical Services for project specific advice.

Contact Kingspan Technical Services for cyclone regions and areas of high localised suction.



Architectural Wall Panels KS1000 (AWP)

Vertically Laid

**Note: Ensure steelwork is suitable for panels and is within tolerance
Min. bearing face for intermediate support is 50mm**

1

b

Apply 6x4mm butyl sealant or gun grade sealant

a

Line, level and fix drip flashing using low profile fasteners. Joints in the drip flashing to incorporate 150mm overlap or butt straps sealed with two runs of gun-grade sealant

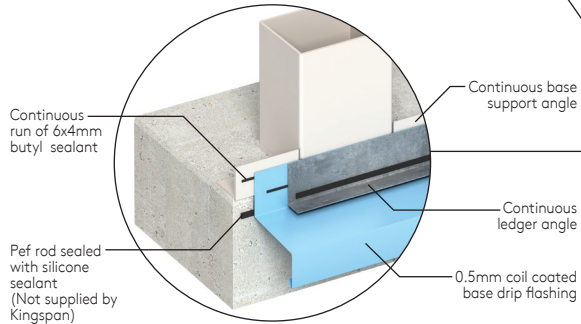

Architectural Wall Panels KS1000 (AWP)

Vertically Laid

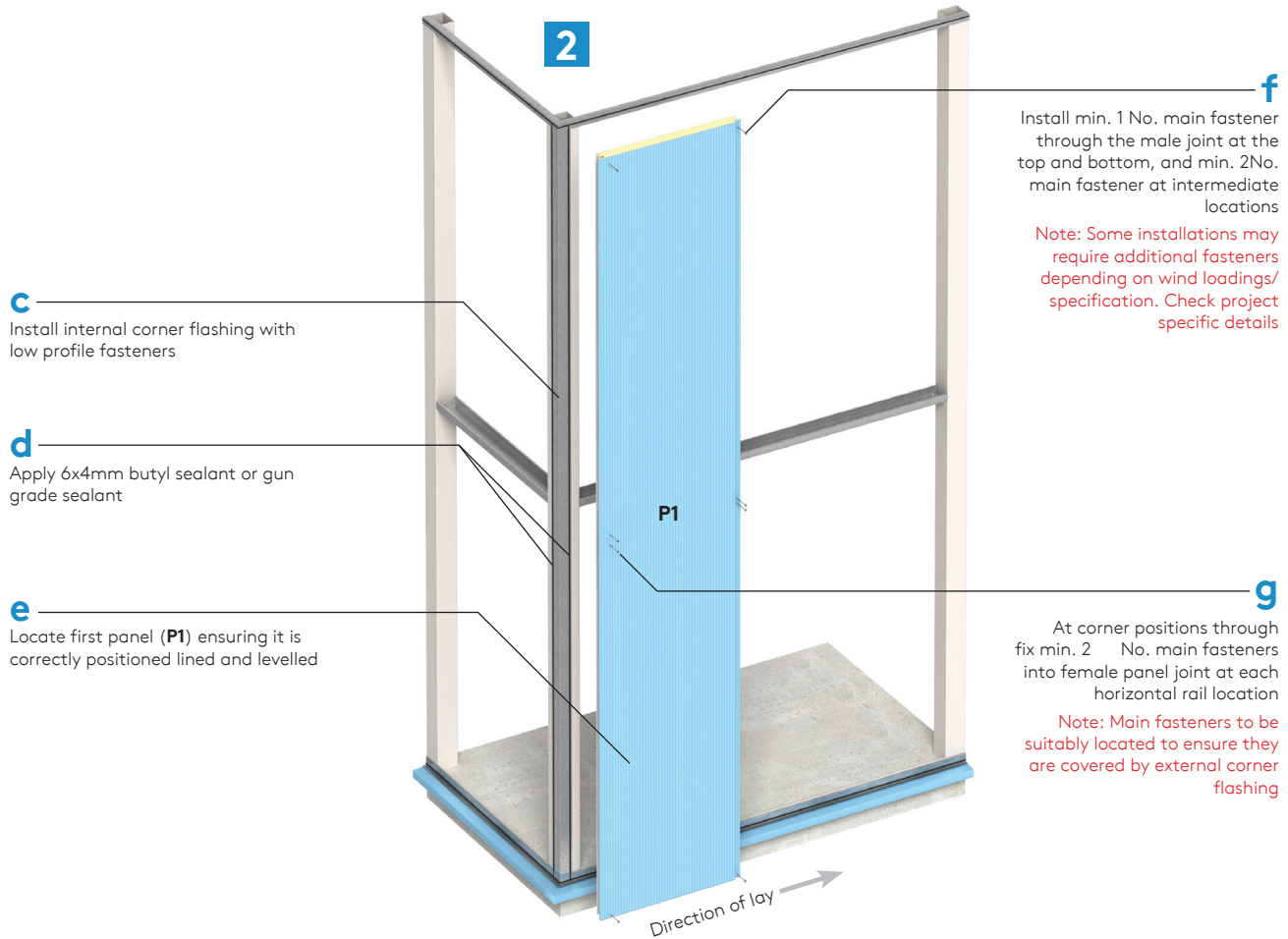

Architectural Wall Panels KS1000 (AWP) Vertically Laid

Vertically Laid

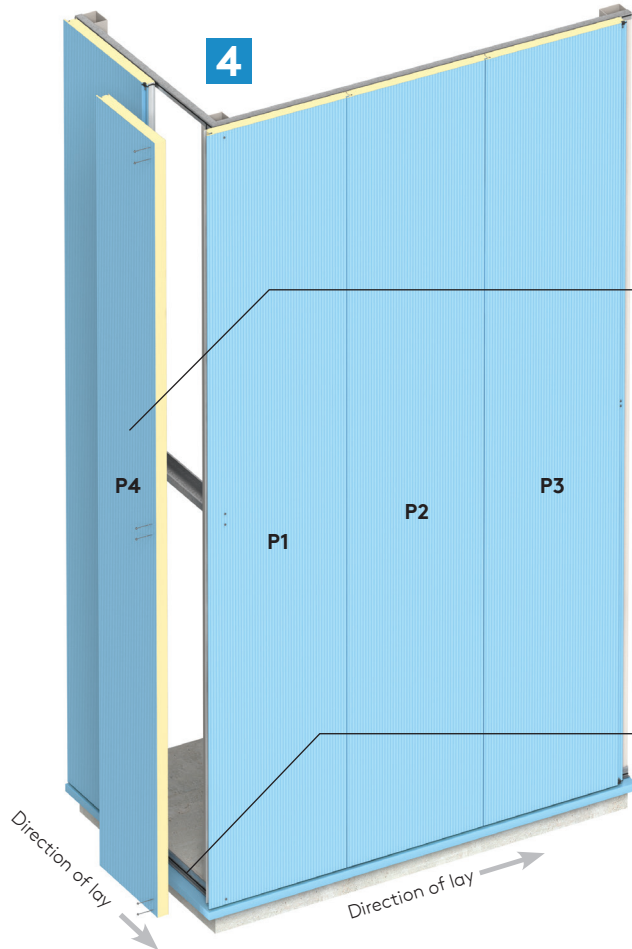

Locate panel (**P4**) in to position ensuring factory applied weather seal is compressed and AWP filler remains in position

Panel Stack Joint

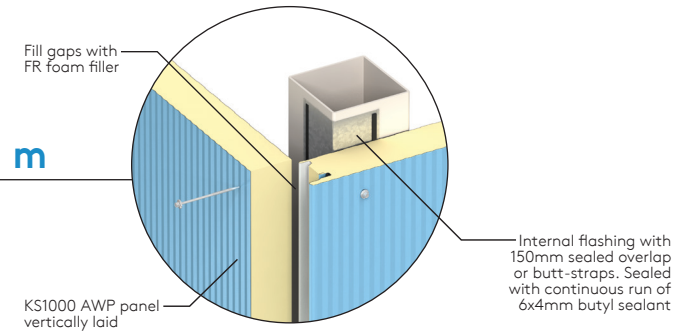
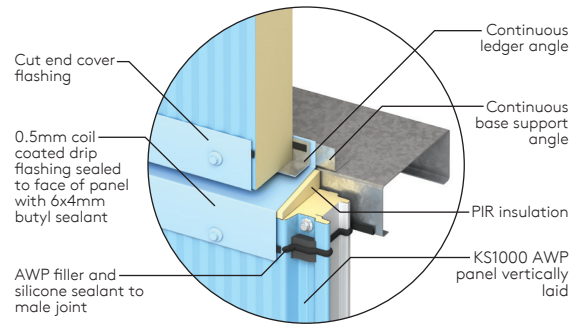

m

Architectural Wall Panels KS1000 (AWP)

Vertically Laid

5

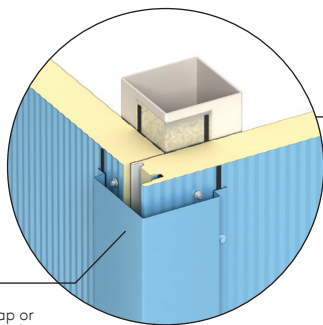

0.5mm coil coated corner flashing with 150mm sealed overlap or butt-straps. Sealed with continuous run of 6x4mm butyl sealant

n

Fix external corner flashing with stitching screws at max. 450mm centres. Joints in the corner flashing to incorporate butt straps sealed with two runs of gun-grade sealant

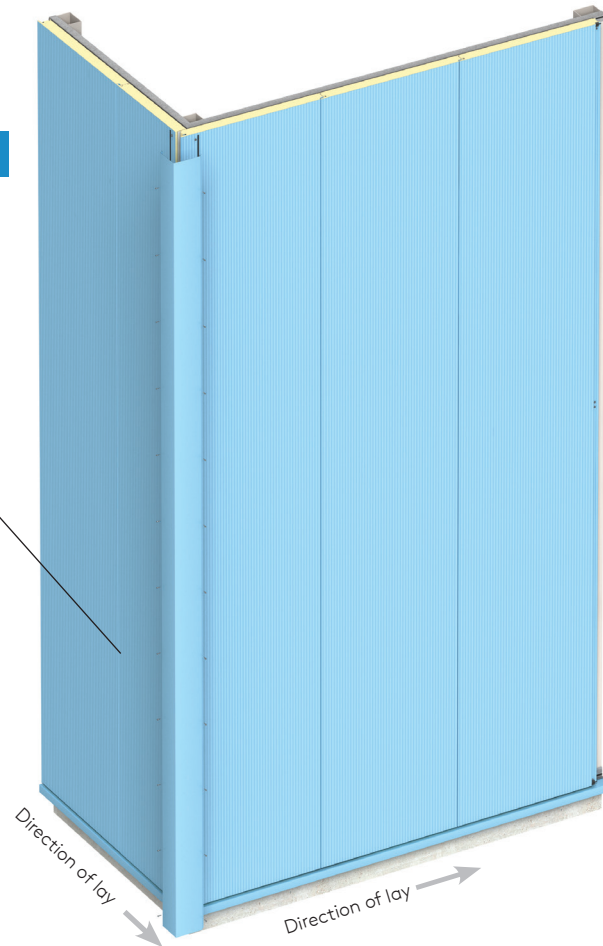

Direction of lay

Direction of lay

Panel Handling

Appropriate personnel protective equipment should always be worn to avoid cuts and abrasions to installers and panels.

Individual panels should always be lifted from a pack and not dragged over others.

The weight of individual panels for lifting can be determined from the information on the packing slip.

For larger panels the contractor would normally arrange to use appropriate material installation equipment to help lift the panels into position.

Protecting Film

When panels are supplied with a plastic protective film this should be removed during site installation.

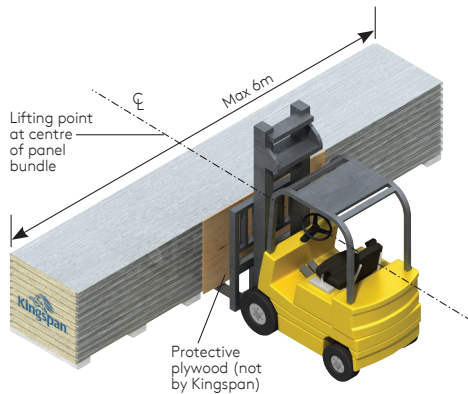

The recommended loading / unloading method for bundles less than or equal to 6m is to use a single forklift with widely spaced forks placed under the centre of the bundle as shown.

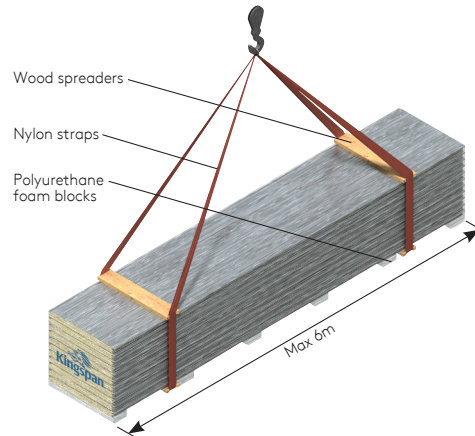

The recommended lifting method for bundles no more than or equal to 6m can be handled with a crane by using nylon straps and wood spreaders as shown.

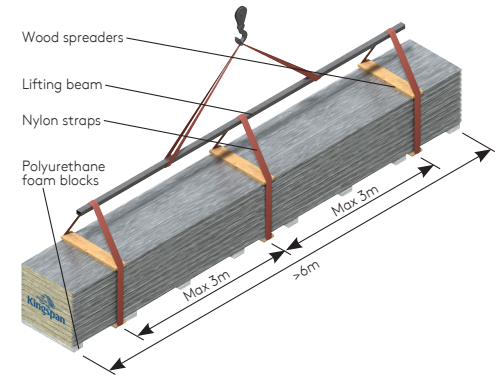

The recommended lifting method for bundles more than 6m, by crane, is by using three points of support. To prevent damage from nylon straps, use wood spreaders at top and bottom at lifting locations as shown.

Panel Handling

Correct and Incorrect Panel Handling

Caution

Individual panels should never be moved in a flat position as excessive flexing may result. Excessive flexing ruptures a panel's core, permanently distorts the facings and may lead to thermal blistering. When moving a panel, it must be turned on its edge first, then supported at each end with as many men as necessary to safely handle.

