

Cavity Batten Note:

Refer to cavity batten layout for batten sizes, types, spacings & fixings.

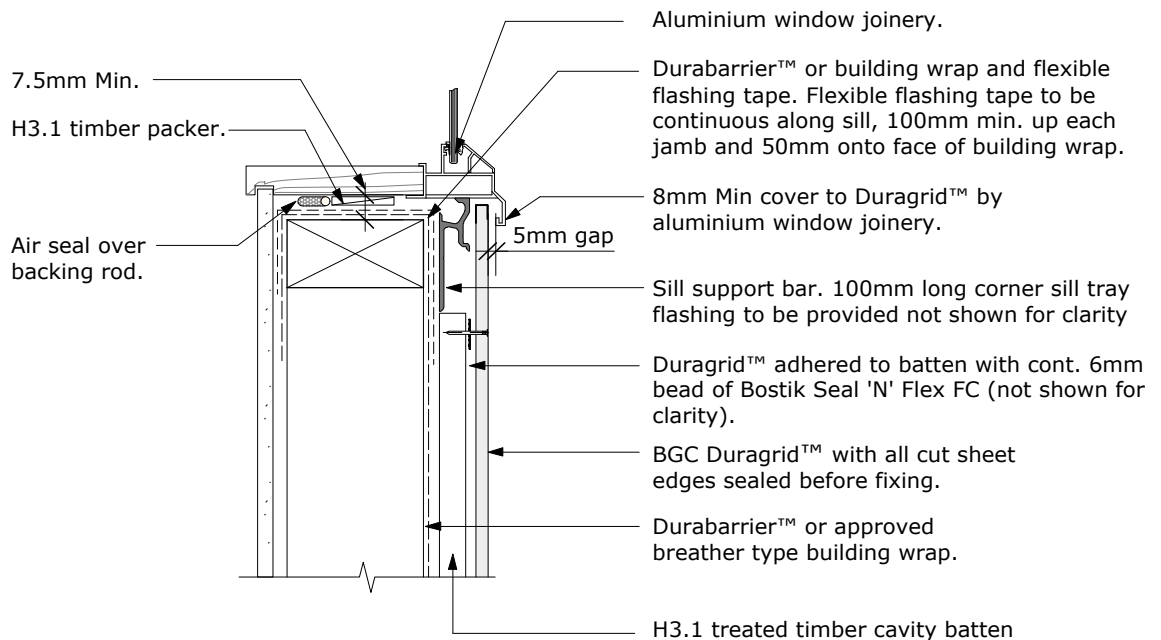

Note. Where DurabARRIER™ is used flashing tape must be applied to the entire opening

PROFILE **BGC Duragrid™**

DETAIL **Window Sill**

DATE **Nov 2011**

SCALE **1:5 @ A4**

DETAIL NO. **D 16**