

20MM CAVITY BATTEN SYSTEM



CEDARSCREEN

VERTICAL

VERTICAL SHIPLAP WEATHERBOARDS



Today's technically advanced cladding systems and enhanced profiling and machining methods, mean that vertical weatherboarding can be manipulated to exploit the full range of possibilities that timber provides.

From the cool clean lines of narrow profiled boards with crisply profiled joints, through to random depth and width weatherboards that evoke images of the richly textured environment that many of our buildings find themselves in.

GENERAL

The Rosenfeld Kidson Cedarscreen Vertical 20mm is a system for vertical shiplap weatherboard external wall cladding utilising a 20mm cavity. The system is used for residential and light commercial building types.

The Cedarscreen Vertical 20mm cavity system comprises of vertical shiplap weatherboards (factory finished to all sides with a migrating wood oil), horizontal and vertical cavity battens, stainless steel or silicon bronze cladding fixings and powder-coated aluminium flashings.

Cedarscreen installation guides are intended to link the end user to best practise and correct installation of the specified system. In the literature we primarily reference Western Red Cedar as the timber cladding material.

Rosenfeld Kidson also offer Larch and Truwood as alternative timber cladding species. These timbers are appraised to comply with B2.3.1 (b).

Where there are key differences in these alternative cladding types, we reference Larch and Truwood separately. This generally relates to the species type scope of use, profiles, finishes, fixing and related details.

These species shall be used in accordance with Rosenfeld Kidson's recommended profiles, fixing, finishing and detailing; in addition to the requirements set out in E2/AS1, B2 and F2.

SCOPE

The Cedarscreen Vertical 20mm system has been tested as an externally fixed vertical wall cladding system to comply with and is limited to the following:

- NZBC Acceptable Solution (E2/AS1/VM1, Paragraph 1.1).
- Testing included Amendment 5 of E2/AS1, including Extra High Wind zones.
- Specific wind pressure up to a maximum ultimate limit state (ULS) 2.5 kPa (2500 Pa).
- Risk score of 0-20 (E2/AS1 tables 1, 2 and 3).
- Timber framing to comply with NZBC NZS 3604.
- NZS 3604 Wind Zones.
- Material, products and processes contained within the building scope of NZS 3604.
- Tested for use with aluminium windows and door joinery to comply with NZS 4211.

New Zealand Building Code (NZBC) performance requirements:

The Cedarscreen Vertical 20mm system if designed and installed as per the Rosenfeld Kidson installation brochures and construction details, will meet the provisions listed below.

- Clause B1 Structure: Performance B1.3.1, B1.3.2 and B1.3.4 and B1.3.3 (a), (h), (j) and (q).
- Clause B2 Durability: B2.3.1 (b) 15 years and B2.3.2, B2/VM1, 1.1.1(a).
- Clause E2 External Moisture: E2.3.2.
- Clause F2 Hazardous Building Materials: Performance F2.3.1.

COMPLIANCE

Cedarscreen Vertical 20mm cavity system is Codemark certified for mandated compliance CM70083. Cedarscreen Vertical is tested fully in accordance with E2/AS1/VM1 External Moisture Verification Method Testing Building Facades and NZS 4284:2008 Testing Building Facades Specific Design. Testing was carried out at an IANZ accredited facility in accordance with Clause 1.0 E2/AS1. The test process included cladding junctions with windows, doors, soffit, penetrations, internal and external corners.

AVAILABLE CAVITY BATTENS

- CS-H 20x45mm horizontal cavity batten.
- CS-V 18x45mm vertical cavity batten.
- CS-V 18x75mm vertical cavity batten.

SPECIES

WESTERN RED CEDAR

Western Red Cedar (*Thuja plicata*) weatherboards are compliant for above ground use in accordance with New Zealand Standard NZS 3602: 2003 Timber and Wood-based Products, specifically B2.3.1 (b), for use in building and when fixed above ground, exceeds the minimum 15-year durability requirement.

LARCH

Siberian Larch (*Larix sibirica*)

Larch is utilised in horizontal and vertical cladding profiles that are compliant with Branz Bulletin 411. Siberian Larch timber grade supplied by Rosenfeld Kidson & Co Ltd is a mixture of Grades I, II, and III, called Unsorted I-III. The Unsorted I-III grade of Larch is compliant with NZS3631:1988 NZ Timber Grading Rules. Larch is independently appraised to show compliance with B2.3.1 (b).

The Larch supplied by Rosenfeld Kidson & Co Ltd has a factory applied oiled finish using Dryden WoodOil. The Larch profile types supplied are available in a band sawn face (BSF).

TRUWOOD®

Thermally modified Ayous

Truwood is utilised in horizontal and vertical cladding profiles that are compliant with Branz Bulletin 411. Truwood is a thermally modified, clear grade, low density hardwood. Truwood is produced using the latest thermal modification technology, which involves applying heat at 160 – 230°C, water vapour and pressure to the timber.

The thermal treatment provides a rich Teak coloured timber with great properties of durability and stability. Truwood is independently appraised to show compliance with B2.3.1 (b).

The Truwood supplied by Rosenfeld Kidson & Co Ltd has a factory applied finish using Dryden WoodOil.

MAINTENANCE

Maintenance shall be carried out as necessary to achieve the required durability of materials, components and junctions. The extent of maintenance is dependent on:

- Type of cladding and components used.
- Position of cladding and components on the building.
- Geographical location, (recoating with Dryden WoodOil will be required more frequently on more exposed northern and western faces).
- Coating manufacturer cleaning and recoating schedules.

Regular maintenance is essential to ensure the performance requirements of the NZBC are met and to maximise serviceability of the system.

Annual inspection of the cladding material must be made to ensure that all aspects of the cladding system, including flashings and joints remain weatherproof. Any damaged areas or areas showing signs of deterioration, which could allow water ingress must be repaired immediately.

Regular cleaning (at least annually) of the Dryden WoodOil coating is required to remove dirt or grime or surface mould. Dirt and grime may be removed with the use of a soft brush, warm water and a light detergent cleaner.

Recoating with Dryden WoodOil will be required throughout the life of the cladding system. Check manufacturer's product specific recoating requirements, as these may vary from product to product.

Rosenfeld Kidson recommends the use of Dryden WoodOil depending on the timber species used with all our exterior weatherboard systems. Recoating must be carried out approximately every 2-3 years in accordance with the manufacturer's instruction.

Note: some stains or film forming cedar coatings may require annual maintenance. Refer to individual supplier's maintenance guides for appropriate product specifications. Ensure ends of weatherboards and cut or exposed edges are recoated during any general maintenance.

SUSTAINABILITY

Western Red Cedar is also favoured by conservationists as the forests of British Columbia, from where our cedar is sourced, are well-managed and certified as such. All our producers carry certification under SFI, CSA, FSC or PEFC. Please refer to the following site for more information regarding this:

www.realcedar.com/why-real-cedar/certification/

Rosenfeld Kidson Larch and Truwood are sourced with FSC® certification providing independent assurance they are sourced from well-managed forests.

SIZES & GRADES

Our weatherboards are available in 18.5mm and 28mm thicknesses.

The standard weatherboard length range is 1.83m to 4.88m, averaging 3.0m. Selected length boards up to 6.1m are available on request as part of a selected length order.

- For use as vertical shiplap or board and batten Rosenfeld Kidson PC1 grade Western Red Cedar is recommended. Any defects or knots should be removed prior to installation. Weatherboards shall be continuous in length between each storey height.
- It is good practice to pre-order weatherboards in the required selected length spread. On-site measuring should confirm the length spread required.

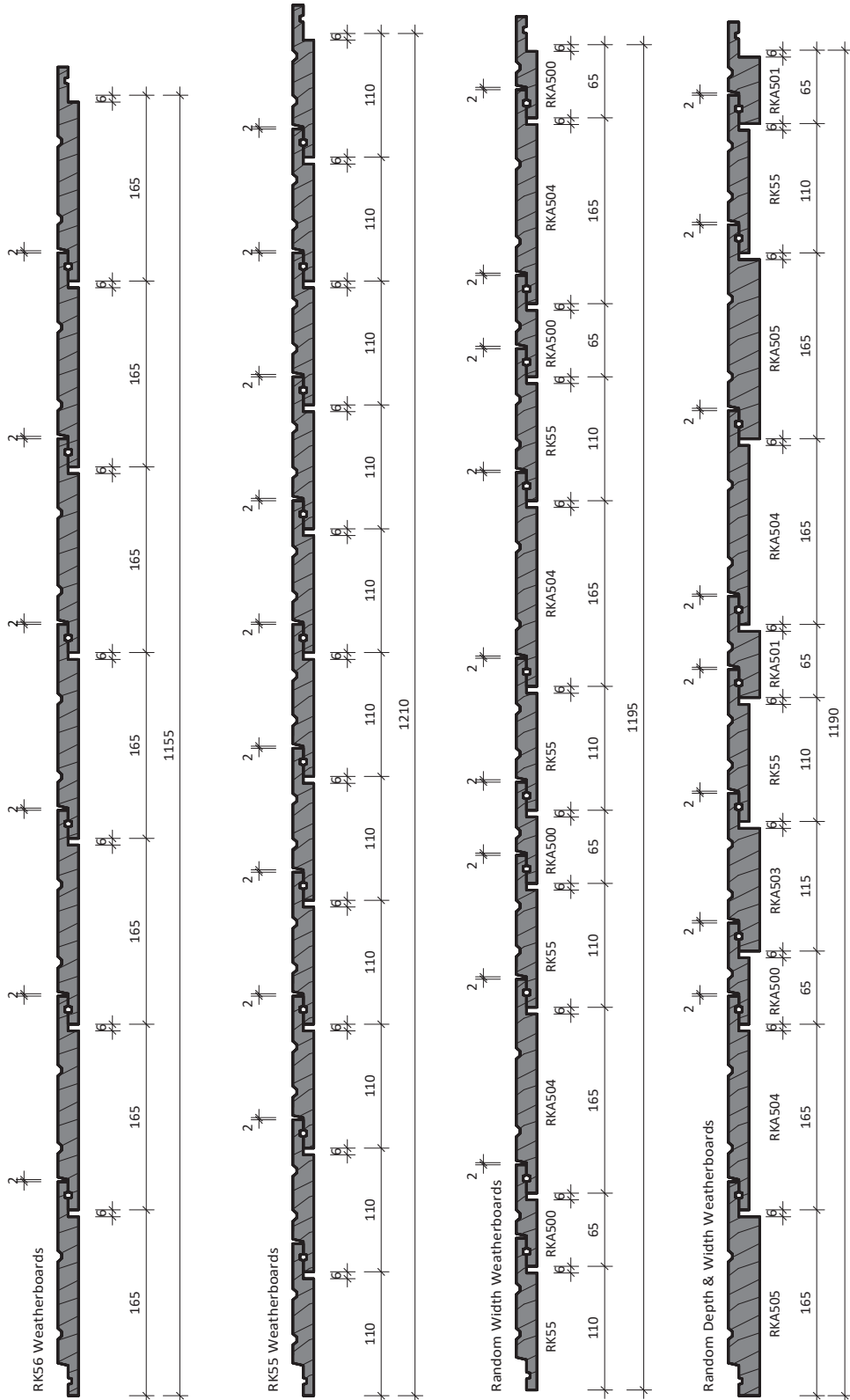

MANUFACTURING

PROFILE RANGE

- Standard profile range Includes RK50, RK51, 52, 53, 54, 55, 56, 57, 58, 59 and RK60.
- Architectural profile range Includes RKA500, RKA501, RKA502, RKA503, RKA505, RKA542, RKA543, RKA544, RKA545, RKA561, RKA562, including paint finish profiles RKA55-PP-U and RKA563-PP-U.

The Truwood weatherboard profiles available from Rosenfeld Kidson are as follows: Vertical shiplap: RK55, RK56, RKA500, RKA502 and RKA504.

The Larch weatherboard profiles available from Rosenfeld Kidson are as follows: Vertical board: RKA503 and RKA505.

Profiles are manufactured to meet the requirements of E2/AS1 (Acceptable Solution). This is achieved with compliance to Clauses 9.4.1 and 9.4.1.1 of E2/AS1 and Clause 9.4.1.2 E2/AS1 vertical shiplap weatherboards. Profiles as per NZS 3617, Branz Bulletin 411 and/or compliance achieved through in-service history, length of service not less than 15 years in all NZ environments B2/VM1 1.1.1 (a).

ACCESSORIES

Fascia

Western Red Cedar fascia.

RK69 135x18.5mm, supplied in lengths 3.9m and longer.

RK70 180x18.5mm, supplied in lengths 3.9m and longer.

RK71 135x28mm, supplied in lengths 3.9m and longer.

RK72 180x28mm, supplied in lengths 3.9m and longer.

RK73 230x28mm, supplied in lengths 3.9m and longer.

INTERNAL AND EXTERNAL CORNERS

External Timber Corners

Western Red Cedar: RK93, RK94, RK95, RK97 and RK42.

Truwood: RK93, RK97 and RK42.

External Powder-coated Aluminium Corners

Western Red Cedar: RKFL-31, RKFL-34 (including RKA901 timber bead), RKFL-35 (including RK41 timber bead) and RKFL-36.

Truwood: RKFL-31 and RKFL-35 (including RK41 timber bead).

Larch: RKFL-34 (including RKA901 timber bead) and RKFL-36.

Aluminium supplied in 6m lengths.

External Boxed Corner

Western Red Cedar cover boards RK91 and RK92, 18.5mm thick boards in widths of 69mm and 90mm, supplied in lengths 2.4m and longer.

Internal

Cedar or Truwood internal corner mould RK41 and Larch internal corner mould RKA901, supplied in lengths 2.4m and longer.

MOULDINGS











Cedar, Larch or Truwood eaves moulds RK32 40x27mm and RK33 26x15mm, supplied in lengths 2.4m and longer.

SCRIBER

Cedar, Larch and Truwood RK12 40x17mm and RK13 40x10mm supplied in selected lengths.



POWDER-COATED ALUMINIUM FLASHINGS

Flashing Code	Profile	Description	Finish	Length
RKFL-09s		65mm x 65mm Internal/External Corner Flashing	Powder-coated black	5.85 m
RKFL-10s		90mm x 90mm Internal/External Corner Flashing	Powder-coated black	5.85 m
RKFL-11		J - mould (23.5mm)	Mill finish or powder-coated black	6.0 m
RKFL-12		20mm Cavity Closure	Powder-coated black	6.0 m
RKFL-17		J - mould (33mm)	Mill finish or powder-coated black	6.0 m
RKFL-31		18mm External Corner Flashing	Mill finish or powder-coated black	6.0 m
RKFL-34		28mm External Corner Flashing	Mill finish or powder-coated black	6.0 m
RKFL-35		18mm External Corner Flashing	Mill finish or powder-coated black	6.0 m
RKFL-36		28mm External Corner Flashing	Mill finish or powder-coated black	6.0 m
RKFL-40		Vertical joint flashing	Mill finish or powder-coated black	6.0 m

ALUMINIUM FLASHING FINISHES

Dulux Duralloy 'Matt Black' is the standard finish on RK extrusions. This coating is suitable for all non-exposed flashings and also in non-coastal environments.

Important: For exposed flashings in coastal zones, Dulux Duratec shall be used.

Visible/exposed flashings (sill flashing, two-piece head flashing and some jamb flashings) are also available in mill-finish. This allows coating in Duratec for coastal environments, or alternative colours to Matt Black and alternative finishes, such as anodised coatings to match window joinery.

When fixing aluminium, only use stainless steel. Silicon bronze (copper) is non-compatible and should not be used.



FINISH

- BSF Band Sawn Face.
- DF Dressed Face or DFS Dressed Faced Sanded (it is recommended dressed face weatherboards are sanded prior to applying coating products).

MOISTURE CONTENT

Western Red Cedar panels are delivered to site air-dried to between 16% and 18% moisture content.

FACTORYCOAT

This is a specifically designed coating process for applying stain and wood oil to our weatherboards. Dryden WoodOil is applied prior to delivery to all faces of the weatherboard profile. These uniquely formulated products will increase the durability and performance of the cladding during its in-service life. Factory coating to all faces not only enhances the visual effect of Cedar, Truwood and Larch but when maintained to manufacturer specifications, it also greatly reduces moisture penetration, limiting excessive hygroscopic movement.

AT TIME OF ORDER

- Check surface finish BSF or DF.
- Check dressed faced weatherboards are face sanded, if being factory oiled.
- Sign off profile confirmation check sheet.
- Sign off colour confirmation check sheet.
- Check pre-order of a minimum 4ltr of Dryden WoodOil for sealing cut or exposed edges.

HANDLING & STORAGE

Care should be taken to protect Western Red Cedar from the elements. All plastic wrapping, timber gluts, packers and strapping should remain intact until stored in a suitable location.

Packets of weatherboards should be stored a minimum 100mm clear from the ground at all times. Storage should be in a dry, enclosed location where temperature and humidity are kept relatively stable i.e. dry, dust free and free from sub trade contamination.

FRAMING

FRAMING

- All framing must comply with NZS 3604.

WALL UNDERLAYS

- Must comply with Table 23 and Clauses 9.1.5 – 9.1.7 E2/AS1.
- Flexible flashing tape as per Clause 4.3.1.1 E2/AS1.

FLEXIBLE WALL UNDERLAYS

- Flexible wall underlays shall be in accordance with Table 23 E2/AS1.
- Flexible wall underlays shall be fixed in accordance with Clause 9.1.7.1 E2/AS1.
- Be run horizontally.
- Have upper sheets lapped over lower sheets to ensure that direction of lap will allow water to be shed outside of the wall underlay.
- Be lapped not less than 75mm at horizontal joints.
- Be lapped not less than 150mm over studs and vertical joints – see manufacturer specifications for taped joint options.
- Flexible wall underlay as per Clause 9.1.5 shall be cut and dressed into all sides of openings as per figure 72A and 72B E2/AS1.
- Flexible flashing tape shall be applied to head and sill framing as shown in figure 72A and 72B E2/AS1. Flexible tape shall comply with parts 3.2 and 4 of ICOB Acceptable Criteria AC 148 and be compliant with the wall underlay.
- Extend 35mm below bottom plate or bearer.
- Be restrained from bulging – use polypropylene tape at 300mm centres tape shall be fixed horizontally and drawn taut refer Clause 9.1.8.5 E2/AS1.

RIGID WALL UNDERLAYS

- Are required in Extra High wind zones – refer to Table 3 and Table 23 E2/AS1.
- Where walls are not lined such as gable ends, attic spaces, an air barrier compliant to Table 23 E2/AS1 shall be fixed to framing prior to installation of cavity battens. For attached garages, underlays to Clause 9.1.3.4 E2/AS1.
- Rigid wall underlays shall be fixed in accordance with Clause 9.1.7.2 E2/AS1.
- Be a minimum 6mm fibre cement sheet or 7mm H3 plywood sheet.
- Be installed with sheet edges fixed over solid framing.
- Be over-fixed with a flexible wall underlay from Table 23 and installed as in Clause 9.1.7.1 E2/AS1.
Note: some proprietary systems may not require the addition of a flexible underlay.
- Flexible wall underlay as per Clause 9.1.5 shall be cut and dressed into all sides of openings as per figure 72A and 72B E2/AS1.
- Flexible flashing tape shall be applied to head and sill framing as shown in figure 72A and 72B E2/AS1. Flexible tape shall comply with parts 3.2 and 4 of ICOB Acceptable Criteria AC 148 and be compliant with the wall underlay.
- Be finished flush with the underside of bottom plate or bearer.

Air seals as per Clause 9.1.6 E2/AS1.

- Windows, doors and other penetration openings shall be provided with flexible air seals installed to minimise the risk of airflow carrying water into the building wall.

GROUND CLEARANCE

As per Clause 9.1.3 and Table 18 E2/AS1.

At ground level the base of the cladding material shall overlap the concrete slab a minimum 50mm (*Note: direct fixed only wall cladding shall be offset horizontally 6mm to avoid capillary action*). The bottom edge of the cladding material shall finish 100mm above a paved surface or 175mm above an unpaved surface.

PENETRATIONS

As per Clauses 9.1.9, 9.1.9.1, 9.1.9.2, 9.1.9.3 and figure 68 E2/AS1. Or visit www.vanluk.co.nz for pipe and cable cavity flashings.

DRAINED CAVITIES

As per Clause 9.1.8 E2/AS1.

Non-structural Cavity Batten options:

CS-H 20x45mm horizontal cavity batten.

1. 18 degree slope to the top and bottom of the cavity batten.
2. Cavity battens are nominal 20x45mm.
3. Castellation dimensions are 25x6mm.

CS-V 18x45mm vertical cavity batten

CS-V 18x75mm vertical cavity batten.

REQUIREMENTS

- Treatment to meet the requirements of NZS 3640.
- Be installed over wall underlay, either flexible or rigid compliant with Table 23 E2/AS1.
- Be compliant with B2/AS1.
- Cavity battens are to be fixed horizontally at maximum 400mm to 480mm centres with studs spacing between 400mm or to a maximum 600mm centres.
- CS-H 20x45mm cavity battens are fixed, by the cladding fixings, to the wall framing.

Diagram A

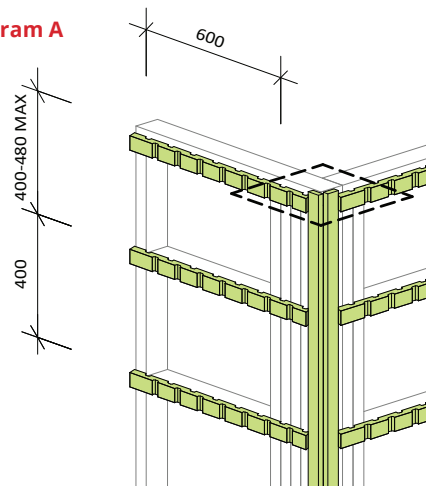

- CS-V vertical cavity battens are used to form a cavity at window jambs and at internal and external corners.
- Sloped edges are to be fixed directing moisture back towards the cladding.
- Battens shall be fixed vertically to jambs 10mm in from the framing edge. Horizontal battens shall be fixed 10mm below the sill framing edge or below the sill support bar.
- Additional sill dwangs may be required to support the weatherboard fixing below the sill support bar.
- Vertical battens shall be fixed at internal and external corners, allow a 10mm gap between all vertical and horizontal battens, CS-V 20x45mm.
- Be drained and open to the exterior at the bottom of the cavity.

Vermin proofing as per Clause 9.1.8.3 E2/AS1.

- Cavity closer to be used in drained cavities at the base of the wall lining and above window heads and inter storey flashings.
- Cavity closure shall provide a minimum ventilation area of 1000mm² per metre length as per figure 66 E2/AS1.
- Be positioned to allow a drip edge to the wall cladding of 10mm at the base of walls and 15mm above window and door head flashings.

FLASHINGS

As per Clause 4.0 E2/AS1.

- Flashing material selection shall comply with Table 20 E2/AS1 and meet the compatibility of Tables 21 and 22 E2/AS1. Flashings shall have a minimum 50mm cover as per Clause 4.5.2 E2/AS1.
- Ensure material thicknesses are as per the requirements of Clause 4.0 E2/AS1 prior to ordering.
- Internal and external back flashings refer figure 79 and Clause 9.4.4.5 E2/AS1.
- Aluminium flashings to be powder coated to all faces and edges.
- Flashing dimensions as per Table 7 E2/AS1.

FIXINGS

Fixing recommendations are based on principals set out in Table 24 E2/AS1.

20x45mm Cavity Batten

- Rosenfeld Kidson flat, rose or pentagon head annular grooved nails 75x3.15mm, stainless steel 316 or silicon bronze or 85x3.2mm when using a rigid underlay.

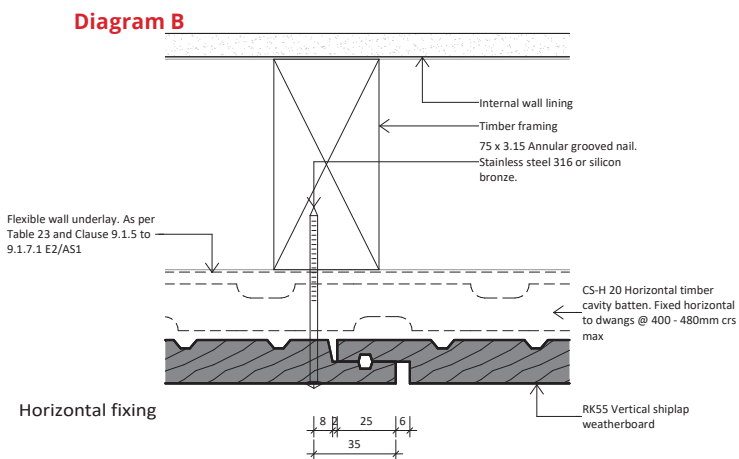

Windows & Doors

The weatherboard system relies on the joinery meeting the requirements of NZS 4211 for the relevant Building Wind Zone or wind pressure.

- Shall be in accordance with Clauses 9.4.6 to 9.4.7 E2/AS1.
- Window profiles to be selected to achieve cover shown in details.
- Wall underlays to wall openings as per Clause 9.1.5 E2/AS1.
- Sill support bar required conforming to EM6 and Clause 9.1.10.5 refer figure 72B E2/AS1.
- For Very High and Extra High wind zones seal head flashing to window flange as per figure 71b E2/AS1.

HEAD FLASHING

- Head flashings shall be fixed with a minimum 35mm cover flashing upstand with additional flexible underlay or tape overlapped over the flashing upstand.
- Extra High wind zones require a minimum 75mm cover flashing to head flashing with additional tape overlapping the flashing up stand.
- Ensure head flashings have a minimum 15 degree fall with a 5mm gap between head flashing and weatherboard refer figure 83 E2/AS1.
- Head flashings shall be fixed with stop-ends to suit the cavity depth, head flashing shall extend to provide 30mm cover or if scribes are used the flashing shall extend 20mm past the finished scribe refer figure 83(c) E2/AS1.
- Window sill joinery cover shall be a minimum 8mm at the sill and 10mm minimum at jambs. Jambs shall be scribed or apply foam bond breaker and continuous protective sealant the full length of the jamb line refer figure 83 E2/AS1.

Air seals as per Clause 9.1.6 E2/AS1.

- Ensure an air seal is provided with a flexible air seal to minimise the risk of airflows carrying water into the building wall. The air seal shall be installed between the reveal or frame and the wrapped opening as per figure 81 E2/AS1. Be installed over a closed cell polyethylene foam (PEF) backing rod.
- And (i) self-expanding polyurethane foam or (ii) sealant complying with clause 9.1.6 (a) and (b) E2/AS1.
- Temporary packers shall be removed after fixing.

FIXING VERTICAL WEATHERBOARDS

LIMITATIONS

Cedarscreen Vertical must only be installed by a registered LBP (Licenced Building Practitioner).

Fixing methods shall be in accordance with Clause 9.4 E2/AS1.

- Check weatherboards are factory oiled on all surfaces including weather grooves prior to delivery.
- Apply Dryden WoodOil to all cut or exposed edges prior to installation.
- Ensure on-site provisions are appropriate allowing for good storage and working space.
- Ensure all timber products are free from sub-trade and climatic contamination during the building process.

FIXING PROCESS

Start the fixing process from either an internal or external corner. The layout of the vertical shiplap weatherboards should be configured against the prevailing wind. Establish an accurate measurement between the starting corner and finishing point, working out an even board set out, taking into account all associated junctions, including window jambs. This will ensure full width boards are allowed for trimming into window jamb to head junctions.

- Jamb to head and sill junctions – ensure weatherboards are full width and continuous in length.
- Ensure vertical weatherboards are continuous in length between inter storey heights.
- Check weatherboard length spread and use appropriately to suit each cladding face.
- Cut weatherboards to length ensuring a minimum 50mm overhang of the bottom plate.
- Weatherboards shall be pre-drilled prior to fixing with a single fixing to each fixing point. Do not brad nail weatherboards prior to face nailing.

CORNERS

Internal Corners

- Internal corners shall be weatherproofed with RKFL09 65x65mm powder-coated back flashing using the RK41 or trim the shiplap from each board and lap the boards into each other forming a tight internal lap.

External Powder-coated Aluminium Corners

- External powder-coated aluminium corners shall be weatherproofed with RKFL 31, 34, 35 and 36 (profiles are extruded 1.5mm to 2.0mm in thickness).

Timber External Corners

- Timber external corners shall be weatherproofed with RKFL09 65x65mm or RKFL10 90x90mm powder-coated back flashings using the RK42, 93, 94, 95 or 97 external corner moulds.

RK93, 94, and 95 profiles are designed to be adhesive fixed with additional support given by the shiplap joint. These profiles are shiplapped to improve the weatherproofing of the cladding junction.

Adhesive fixed corners: Refer to Sika bond method statement for use of 3N Primer and Sikaflex 11FC with Western Red Cedar.

Diagram C

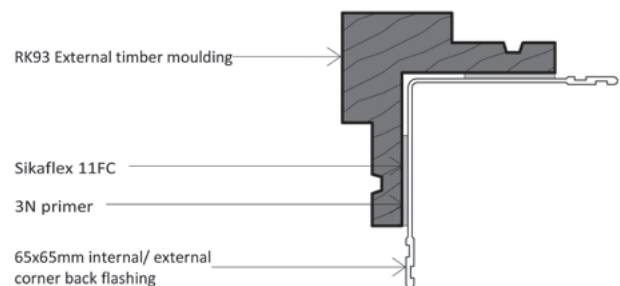

FIXINGS

Weatherboards shall be fixed through the wall underlay to the framing as per the below recommendations that are based on principals set out in Table 24 E2/AS1.

- Fixings shall be pre-drilled and hand driven. Do not brad nail weatherboards prior to face nailing.
- 35mm to 40mm beyond the lapped edge. Ensure boards are single nailed and beyond the boards shiplap.
- A minimum of 35mm fixing penetration into framing is required.
- Vertical weatherboards shall be fixed to dwangs at between 400mm to 480mm centres.
- 20x45mm cavity battens are fixed, by the cladding fixings, to the wall framing.
- Weatherboards shall be lapped to provide 25mm effective cover with a minimum 2mm gap at the overlap between boards.
- Ensure the 6x3mm weathergrooves are lined up to form a 6x6mm weathergroove.

WINDOWS & DOORS

- Ensure head flashing stop-ends are in place prior to nailing weatherboards.
- Jamb shall be scribed with the RK12 profile or weather proofed with a foam bond breaker with a continuous protective sealant bead along the jamb line refer figure 83 (c) E2/AS1.
- Scribes are to be sealed to weatherboards.

FINISHING

Apply the finishing coat of Dryden WoodOil.
Use Dryden WoodOil as per manufacturer specifications.

Recommended coverage rates for on-site application of Dryden WoodOil. (These are indicative rates and coverage may vary depending on site conditions).

Dryden WoodOil is a deep, migrating oil that not only adds colour but enhances the timber's natural properties, protecting surface fibres and stabilising the timber's cell structure. To ensure an optimum performance level is achieved, your cladding should be annually cleaned and maintained in accordance with Dryden manufacturer maintenance schedules.

- Recommended coverage rate for BSF 8-10 m² per ltr.
- Recommended coverage rate for DF 10-12 m² per ltr.





WORKINGSPEC

20MM VERTICAL QR CODE SHEET

RK93 EXT. CORNER ON 20MM

<http://wksp.nz/rk-v20-fu22>

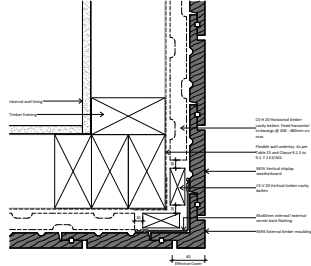

RKFL-34 T-FLASHING EXT. CORNER ON 20MM

<http://wksp.nz/rk-v20-fu28>

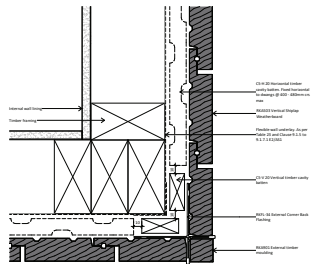

STANDARD WINDOW TRIMMING ON 20MM

<http://wksp.nz/rk-v20-fu01-03>

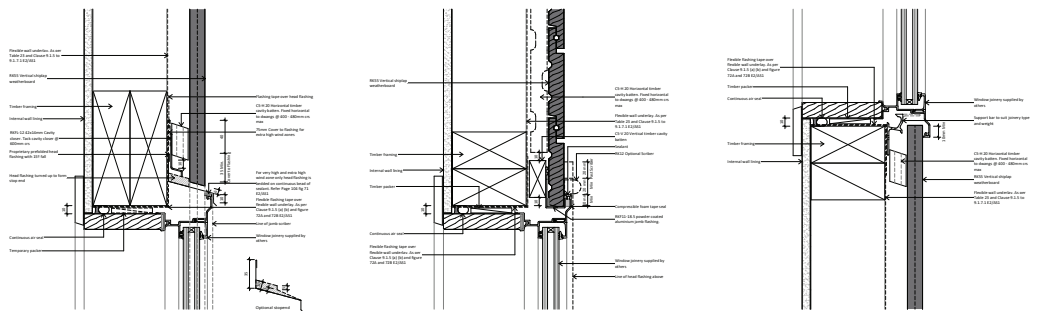

interactive assembly instructions available

To view interactive, 3D assembly instructions install the **WorkingSpec** app and scan the appropriate QR code, or visit the website listed.

Get **WorkingSpec** from the App Store or Google Play.



E: rk@rosenfeldkidson.co.nz
W: www.rosenfeldkidson.co.nz
www.cedarscreen.co.nz

Auckland:
T: +64 9 573 0503
F: +64 9 573 0504
513 Mount Wellington Highway,
Mount Wellington,
Auckland 1060

Christchurch:
T: +64 3 349 3316
F: +64 3 349 3317
15 Edmonton Road, Hornby,
Christchurch 8042