

HomeRAB™ Pre-Cladding RAB™ Board

Installation Manual

March 2026 New Zealand





We value your feedback!

To continue with the development of our products and systems, we value your input. Please send any suggestions, including your name, contact details, and relevant sketches to:

Ask James Hardie™
literaturefeedback@jameshardie.co.nz

Make sure your information is up to date

When specifying or installing Hardie™ fibre cement products, ensure that you have the current manual. Additional installation information, warranties and warnings are available at www.jameshardie.co.nz or **Ask James Hardie™** on 0800 808 868.

Contents

1	Introduction	4	7	Product Information	60
1.1	HomeRAB™ Pre-Cladding	4	7.1	General	60
1.2	RAB™ Board 6mm	4	7.2	Durability	60
1.3	RAB™ Board 9mm	4	7.3	Alpine Regions	60
1.4	Key Benefits	4			
2	Safe Working Practices	10	8	Finishes and Maintenance	61
2.1	Storage and Delivery	13		Product Warranty	62
2.2	Tips For Safe and Easy Handling of HomeRAB™ Pre-Cladding and RAB™ Board	13			
3	Applications	14			
3.1	Pre-Cladding Products by James Hardie	14			
3.2	Stud To Top Plate Fixing	15			
3.3	Seismic Deflections	15			
3.4	Membranes	15			
4	Framing and Fixings	16			
4.1	Framing	16			
4.2	Fixings	16			
4.3	Fastener Durability	17			
4.4	Clearances	19			
5	Installation	23			
5.1	Board Layout	23			
5.2	Stud To Top Plate Fixing	34			
5.3	Flashings	36			
6	Bracing	44			
6.1	Bottom Plate Fixing/Hold Down Restraints	44			
6.2	Fastener Durability and Size	44			
6.3	Sheet Nailing	44			
6.4	Sheet Orientation	45			
6.5	Service Penetrations	45			

1 Introduction

James Hardie manufactures two pre-cladding products called HomeRAB™ Pre-Cladding and RAB™ Board.

1.1 HomeRAB™ Pre-Cladding

HomeRAB™ Pre-Cladding is a 4.5mm thick fibre cement sheet which is sealed on the face and edges and is used as a rigid air barrier for residential buildings within the scope of the NZS 3604. HomeRAB™ Pre-Cladding is manufactured by James Hardie and complies with the requirements of the AS/NZS 2908.2.

It acts as temporary weather protection during construction, ideal for renovations or new construction. It is suitable for use as rigid underlay in residential buildings as per Subsection 9.1.3 of E2/AS1 and complies with the requirements of Table C.2.1.1 of E2/AS1. HomeRAB™ Pre-Cladding is suitable to withstand wind pressures experienced in all wind zones up to and including Very High (VH) wind zone as specified in the NZS 3604. HomeRAB™ Pre-Cladding doesn't get fatigued or tear under the wind pressures exerted on it in the long term. HomeRAB™ Pre-Cladding has been tested to withstand wind pressures up to VH wind zone.

1.2 RAB™ Board 6mm

RAB™ Board 6mm thick fibre cement sheet is sealed on its face and edges and is suitable for use as rigid air barrier in NZS 3604 or SED e.g. hospitals, schools, commercial etc. up to a design wind pressure 4.5kPa (ULS).

RAB™ Board 6mm has been tested to satisfy the requirements of Paragraph 9.1.6.4 of E2/AS1.

Flexible underlays are not deemed suitable for wind pressures above VH wind zone as per Paragraph 9.1.6.2 of Clause E2 of the NZBC.

1.3 RAB™ Board 9mm

RAB™ Board 9mm thick sheet is sealed on the face and edges and is suitable for use as a rigid air barrier in NZS 3604 or SED e.g. hospitals, schools, commercial etc. up to a design wind pressure 4.5kPa(ULS).

RAB™ Board 9mm has been tested to satisfy the requirements of Paragraph 9.1.6.4 of E2/AS1.

Flexible underlays are not deemed suitable for wind pressures above VH wind zone as per Paragraph 9.1.6.2 of Clause E2 of the NZBC.

RAB™ Board 9mm is an ideal rigid backing board for use behind facades to improve structural stiffness, acoustic performance or fire performance etc.

It is an ideal product for specific design shear walls where higher structural stiffness is required.

1.4 Key Benefits

The products provide the following benefits:

- Resistant to moisture damage and rotting when installed correctly
- Integral sealer applied on the face and edges repels moisture rapidly and helps resist moisture penetration
- Provides temporary weathertightness to the building envelope until the final claddings are installed
- Reduces uncontrolled air movement within the wall cavity and therefore enhances thermal efficiency of external wall
- Provides general rigidity to the entire structure
- An efficient way to achieve structural bracing

- Quicker installation with minimum taping option.
- Its limited combustibility classification in conjunction with compliant claddings makes it suitable for use close to boundaries and comply with horizontal (C3.5) or vertical (C3.7) fire spread control requirements for residential or commercial buildings.

This manual covers the use of HomeRAB™ Pre-Cladding and RAB™ Board in external wall pre-cladding applications only. Further information relating to HomeRAB™ Pre-Cladding and RAB™ Board is also available in the following James Hardie design manuals:

- Fire and Acoustic Design Manual
- Bracing Design Manual

The Specifier or other responsible party for the project must ensure that the information in this manual is appropriate for the intended application and that specific design and detailing is undertaken for areas which are not covered in this manual.

HomeRAB™ Pre-Cladding and RAB™ Board have a CodeMark certificate that demonstrates the compliance with New Zealand Building Code (NZBC). CodeMark certificate can be viewed under the Product Register on MBIE web site www.tepae.building.govt.nz

Refer to CodeMark Certificate GM-CM30130 for more information.



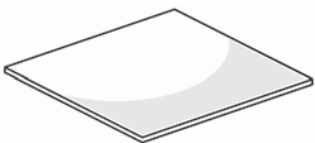
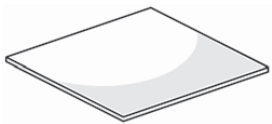
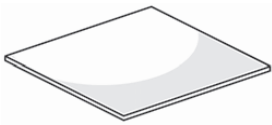
HomeRAB™ Pre-Cladding and RAB™ Board have been BRANZ appraised. This should be read in conjunction with this installation manual. BRANZ Appraisal No. 611 can be viewed on www.jameshardie.co.nz or www.branz.co.nz.



Make sure your information is up to date

When specifying or installing James Hardie products, ensure you have the current manual. If you're not sure you do, or you need more information, visit www.jameshardie.co.nz or Ask James Hardie™ on 0800 808 868.

Table 1

HomeRAB™ Pre-Cladding				
Product Information	Description	Sheet Sizes		
	A fibre cement sheet with a green water repellent sealer applied on the face and edges. Installed with green side facing out. Approximate mass: 6.5 kg/m ²	Thickness: 4.5mm		
		Length (mm)	Width (mm)	Code
		2450	1200	404766
		2750	1200	404768
RAB™ Board 6mm				
Product Information	Description	Sheet Sizes		
	A fibre cement sheet with a green water repellent sealer applied on the face and edges. Installed with green side facing out. Approximate mass: 8.6 kg/m ²	Thickness: 6mm		
		Length (mm)	Width (mm)	Code
		2450	1200	402980
		2750	1200	405131
		3000	1200	402981
RAB™ Board 9mm				
Product Information	Description	Sheet Sizes		
	A fibre cement sheet with a green water repellent sealer applied on the face and edges. Installed with green side facing out. Approximate mass: 12.2 kg/m ²	Thickness: 9mm		
		Length (mm)	Width (mm)	Code
		2450	1200	405132
		2750	1200	404972
		3000	1200	404971

Note: All dimensions and masses provided are approximate only and are subject to manufacturing tolerances. Masses are based on Equilibrium Moisture Content (EMC) of product.

Table 2






Accessories/tools supplied by James Hardie			
	HomeRAB™ 4.5 Horizontal Flashing 3000mm long for horizontal joints CODE: 305798		Hardie™ Blade Saw Blade 184mm diameter, Poly diamond blade for fast, clean cutting of Hardie™ fibre cement. CODE: 300660
	RAB™ 6mm Horizontal Flashing 3000mm long for horizontal joints CODE: 305152		Hardie™ Knife For easy cutting of fibre cement sheets. CODE: 305926
	RAB™ 9mm Horizontal Flashing 3000mm long for horizontal joints CODE: 305945		

Table 3

Components not supplied by James Hardie

James Hardie recommends the following products for use in conjunction with its HomeRAB™ Pre-Cladding and RAB™ Board products. James Hardie does not manufacture these products and does not provide a warranty for their use. Please contact component manufacturer for information on their warranties and further information on their products.

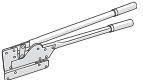

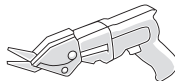
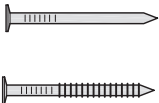

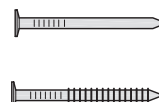



	<p>Hand guillotine Guillotine for cutting fibre cement.</p>		<p>Sealing tape/window flashing tape Tape used to seal vertical joints and flash around window, door and pipe penetrations. Thermakraft™ Premium Joining Tape, Theraflash™ High Adhesion Window Flashing Tape - Thermakraft™ Ltd 0800 806 595 SUPER-STICK Building Tape® - Marshall Innovations 0800 776 9727 3M™ All Weather Flashing Tape 8067 - 3M™ 0800 474 787</p>
	<p>Electric shear/fibreshear</p>		
	<p>Fibre cement nails 40 x 2.8mm hot dipped galvanised Hardie™ Flex nails as per Table 6. 40 x 2.8mm stainless steel Hardie™ Flex nails as per Table 6.</p>		<p>General installation - Nail gun and nails Galvanised/stainless steel round head gun nails minimum length required for specific application.</p>
	<p>Fibre cement nails 50 x 2.8mm hot dipped galvanised Hardie™ Flex nails as per Table 6. 50 x 2.8mm stainless steel Hardie™ Flex nails as per Table 6.</p>		<p>Bracing installation - Nail gun and nails Galvanised/stainless steel round head gun nail minimum length required for specific application. Refer to Section 4.2.</p>
	<p>Tusk 160mm diameter blade Blade for fast, clean cutting of Hardie™ fibre cement</p>		<p>Penetration Seals OneSeal Multi-Fit by Thermakraft™: 0800 806 595 Trade-Seal by Marshall Innovations: 0800 776 9727</p>

Figure 1: HomeRAB™ Pre-Cladding/RAB™ Board with Linea™ Weatherboard

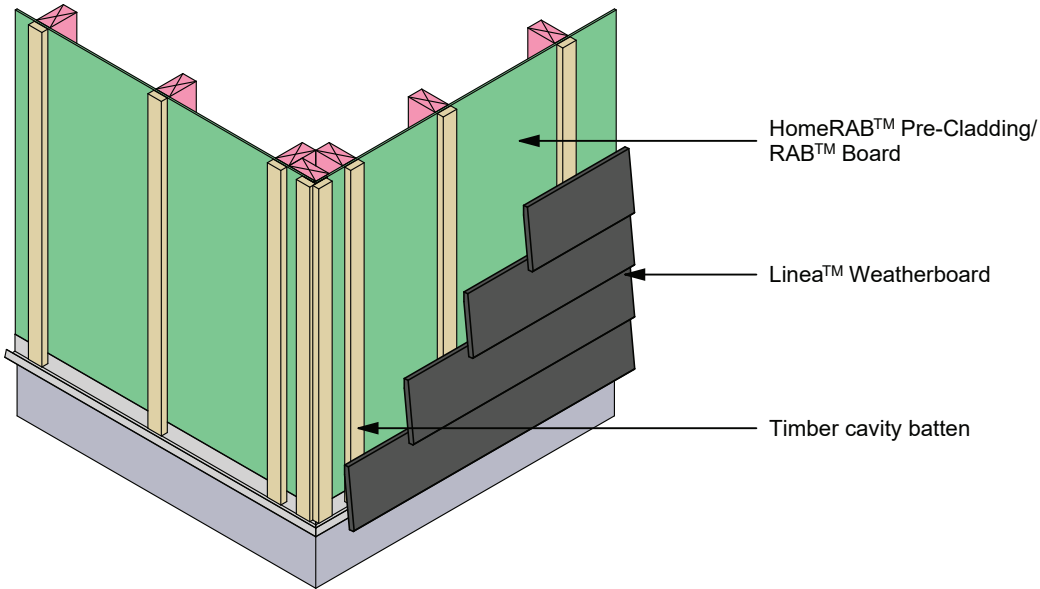
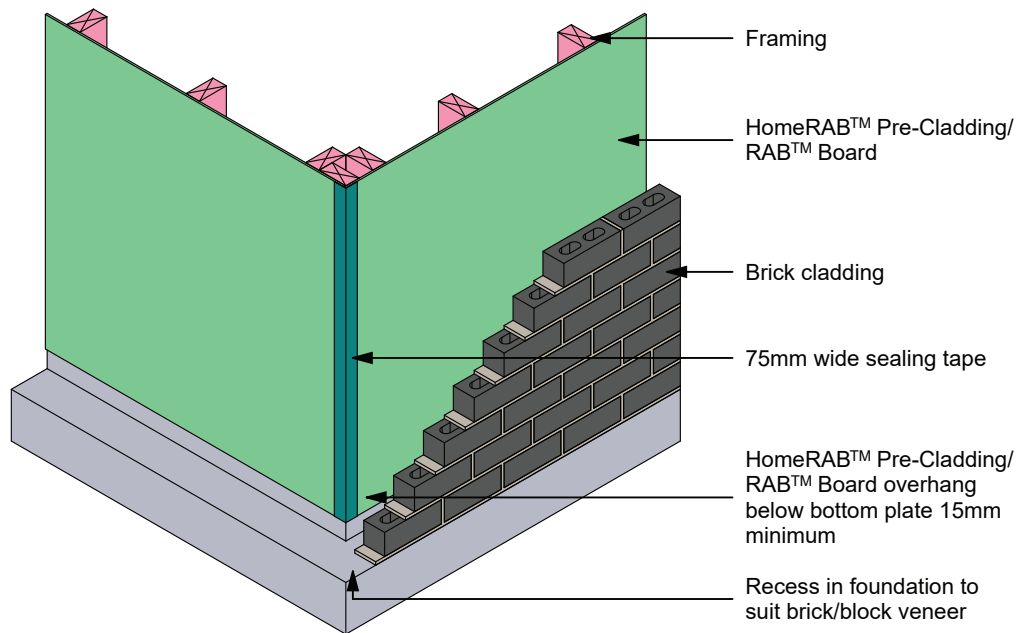


Figure 2: HomeRAB™ Pre-Cladding/RAB™ Board with brick/block cladding



2 Safe Working Practices

WARNING - DO NOT BREATHE DUST AND CUT ONLY IN WELL VENTILATED AREA

Hardie™ fibre cement products contain sand, a source of respirable crystalline silica. May cause cancer if dust from product is inhaled. Causes damage to lungs and respiratory system through prolonged or repeated inhalation of dust from product.

Intact fibre cement products are not expected to result in any adverse toxic effects. The hazard associated with fibre cement arises from the respirable crystalline silica present in dust generated by activities such as cutting, rebating, drilling, routing, sawing, crushing, or otherwise abrading fibre cement, and when cleaning up, disposing of or moving dust.

When doing any of these activities in a manner that generates dust, follow James Hardie instructions and best practices to reduce or limit the release of dust.

If using a dust mask or respirator, use an AS/NZS 1716 P1 filter and refer to Australian/New Zealand Standard 1715:2009 Selection, Use and Maintenance of Respiratory Protective Equipment for more extensive guidance and more options for selecting respirators for workplaces. For further information, refer to our installation instructions and Safety Data Sheets available at www.jameshardie.co.nz.

FAILURE TO ADHERE TO OUR WARNINGS, SAFETY DATA SHEETS, AND INSTALLATION INSTRUCTIONS MAY LEAD TO SERIOUS PERSONAL INJURY OR DEATH.

Crystalline Silica is

- Commonly known as sand or quartz
- Found in many building products e.g. concrete, bricks, grout, wallboard, ceramic tiles, and all fibre cement materials

Why is Crystalline Silica a health hazard?

- Silica can be breathed deep into the lungs when present in the air as a very fine (respirable) dust
- Exposure to silica dust without taking the appropriate safety measures to minimise the amount being breathed in, can lead to a potentially fatal lung disease – silicosis – and has also been linked with other diseases including cancer. Some studies suggest that smoking may increase these risks
- The most hazardous dust is the dust you cannot see!

When is Crystalline Silica a health hazard?

- It's dangerous to health if safety protocols to control dust are not followed when cutting, drilling or rebating a product containing crystalline silica
- Products containing silica are harmless if intact (e.g. an un-cut sheet of wall board)

Avoid breathing in crystalline silica dust

Safe working practices

- ✗ NEVER use a power saw indoors or in a poorly ventilated area
- ✗ NEVER dry sweep
- ✓ ALWAYS use M Class or higher vacuum or damp down dust before sweeping up
- ✗ NEVER use grinders
- ✓ ALWAYS use a dust reducing circular saw equipped with a sawblade specifically designed to minimise dust creation when cutting fibre cement – preferably a sawblade that carries the Hardie™ Blade logo or one with at least equivalent performance – connected to an M Class or higher vacuum
- ✓ Before cutting warn others in the area to avoid dust
- ✓ ALWAYS follow tool manufacturers' safety recommendations
- ✓ ALWAYS expose only the minimum required depth of blade for the thickness of fibre cement to be cut
- ✓ ALWAYS wear a properly-fitted, approved dust mask or respirator P1 or higher in accordance with applicable government regulations and manufacturer instructions
- ✓ Consider rotating personnel across cutting tasks to further limit respirable silica exposures.

Use one of the following methods for cutting HomeRAB™ Pre-Cladding and RAB™ Board 6mm

Best

- Hardie™ Knife
- Hand guillotine
- Fibreshear

Better

Dust reducing circular saw equipped with Hardie™ Blade Saw Blade and connected to a M Class or higher vacuum.

When cutting outdoors

- ✓ Make sure you work in a well ventilated area
- ✓ Position cutting station so wind will blow dust away from yourself and others in the working area
- ✓ Rotate employees across cutting task over duration of shift
- ✓ Cut products with a Hardie™ Blade Saw Blade (or equivalent) and a dust reducing circular saw connected to a M Class or higher vacuum
- ✓ When sawing, sanding, rebating, drilling or machining fibre cement products, always:
 - Wear your P1 or higher (correctly fitted in accordance with manufacturers' instructions), ask others to do the same.
 - Keep persons on site at least 2 metres and as far as practicable away from the cutting station while the saw is in operation
 - If you are not clean shaven, then use a powered air respirator with a loose fitting head top
 - Wear safety glasses
 - Wear hearing protection
- ✓ Make sure you clean up BUT never dry sweep. Always hose down with water/wet wipe or use an M Class or higher vacuum

When cutting indoors

- ✗ Never cut using a circular saw indoors
- ✓ Position cutting station in a well ventilated area
- ✓ Cut ONLY using a Hardie™ Knife, hand guillotine or fibreshears (manual, electric or pneumatic)
- ✓ Make sure you clean up BUT never dry sweep. Always hose down with water/wet wipe or use an M Class or higher vacuum

Use the following method for cutting RAB™ Board 9mm

Dust reducing circular saw equipped with Hardie™ Blade Saw Blade and M Class or higher vacuum.

When cutting

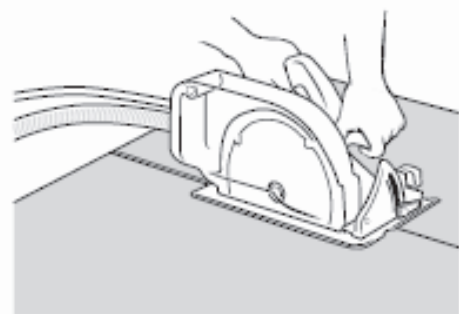
- ✓ Work outdoors only
- ✓ Make sure you work in a well ventilated area
- ✓ Position cutting station so wind will blow dust away from yourself and others in the working area
- ✓ Rotate employees across cutting task over duration of shift
- ✓ Cut products with a Hardie™ Blade Saw Blade (or equivalent) and a dust reducing circular saw connected to a M Class or higher vacuum
- ✓ When sawing, sanding, rebating, drilling or machining fibre cement products, always:
 - Wear your P1 or higher (correctly fitted in accordance with manufacturers' instructions), ask others to do the same.
 - Keep persons on site at least 2 metres and as far as practicable away from the cutting station while the saw is in operation.
 - If you are not clean shaven, then use a powered air respirator with a loose fitting head top
 - Wear safety glasses
 - Wear hearing protection
 - When others are close by, ask them to do the same
- ✓ Make sure you clean up BUT never dry sweep. Always hose down with water/wet wipe or use an M Class or higher vacuum

If concern still exists about exposure levels or you do not comply with the above practices, you should always consult a qualified industrial hygienist or contact James Hardie for further information.

Working instructions

Hardie™ Blade Saw Blade

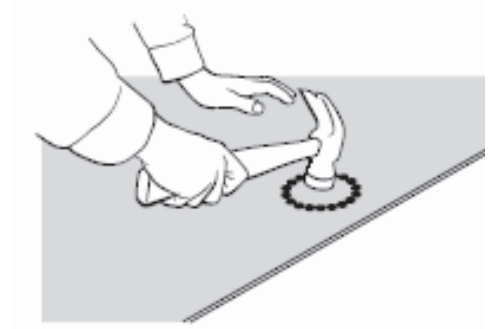
The Hardie™ Blade Saw Blade used with a dust-reducing saw is ideal for fast, clean cutting of Hardie™ fibre cement products. A dust-reducing saw uses a dust collector connected to a M Class or higher vacuum. When sawing, clamp a straight edge to the sheet as a guide and run the saw base plate along the straight edge when making the cut.



Hole forming

For smooth clean cut circular holes:

- Mark the centre of the hole on the sheet
- Pre-drill a 'pilot' hole
- Using the pilot hole as a guide, cut the hole to the appropriate diameter with a hole saw fitted to a heavy duty electric drill



For irregular holes:

- Small rectangular or circular holes can be cut by drilling a series of small holes around the perimeter of the hole then tapping out the waste piece from the sheet face
- Tap carefully to avoid damage to sheets, ensuring that the sheet edges are properly supported

2.1 Storage and Delivery

Keeping products and people safe

Off loading

- ✓ Hardie™ fibre cement products should be off-loaded carefully by hand or by forklift
- ✓ Hardie™ fibre cement products should not be rolled or dumped off a truck during the delivery to the jobsite

Storage

Hardie™ fibre cement products should be stored:

- ✓ In their original packaging
- ✓ Under cover where possible or otherwise protected with a waterproof covering to keep products dry
- ✓ Off the ground – either on a pallet or adequately supported on timber or other spacers
- ✓ Flat so as to minimise bending

Hardie™ fibre cement products must not be stored:

- ✗ Directly on the ground
- ✗ In the open air exposed to the elements

James Hardie is not responsible for damage due to improper storage and handling.

2.2 Tips For Safe and Easy Handling of HomeRAB™ Pre-Cladding and RAB™ Board

- ✓ Carry with two people
- ✓ Hold near each end and on edge
- ✓ Exercise care when handling sheet products to avoid damaging the edges/corners

3 Applications

HomeRAB™ Pre-Cladding is suitable for use as a rigid air barrier for residential buildings up to and including VH wind zone within the scope of the NZS 3604 and E2/AS1. HomeRAB™ Pre-Cladding is fixed directly to the framing. The vertical joints are sealed over the face of the HomeRAB™ Pre-Cladding. HomeRAB™ Pre-Cladding is suitable for use behind all Hardie™ fibre cement claddings or alternative claddings such as brick, timber weatherboard, EIFS etc.

RAB™ Board is suitable for use as a rigid air barrier in EH wind zone in residential or SED project applications to withstand high wind pressures in conjunction with cladding/commercial facades. In these applications, RAB™ Board is fixed directly to the framing. The vertical joints are sealed over the face of the RAB™ Board using joint flashing tape.

3.1 Pre-Cladding Products by James Hardie

HomeRAB™ Pre-Cladding and RAB™ Board can remain exposed to the external elements for a maximum of 180 days prior to the external cladding being installed.

The RAB™ Board can be used as a backing board behind other proprietary claddings i.e. stack stone which comply with the NZBC requirements. Proprietary cladding must be installed as per their manufacturing specifications. In these applications, a flexible underlay must be used as a slip layer to cover RAB™ Board and ensure a separation between mortars and RAB™ Board. The RAB™ Board is fixed over a minimum 18mm thick cavity batten for these applications.

The claddings/facades used over HomeRAB™ Pre-Cladding or RAB™ Board must satisfy the various performance requirements of the NZBC.

Horizontal profiled metal and uPVC claddings must not be direct fixed over HomeRAB™ Pre-Cladding or RAB™ Board. These must be fixed over an underlay or overlay the HomeRAB™ Pre-Cladding or RAB™ Board using the cavity construction method.

Vertical profiled metal cladding can be direct fixed over HomeRAB™ Pre-Cladding or RAB™ Board with a flexible underlay separator to comply with manufacturers recommendations.

The cladding fastener length must be increased by 5mm minimum to maintain the required nail pull out strength.

In case of gable end trusses sitting on top plates of external wall frame, the frame size must comply with the minimum timber sizes stipulated for wall frames in Section 8 of the NZS 3604.

The minimum width sheet recommended is to be 200mm. This is to ensure fixings to each edge.

3.1.1 Temporary weather protection

Installation of internal lining can be started after HomeRAB™ Pre-Cladding or RAB™ Board have been installed on the exterior of the building envelope. In order to achieve this, all sheet joints and penetrations must be sealed and the roof, soffit lining, windows/doors (including head flashings and airseals) must have been installed to ensure the building is weathertight before starting the installation of internal linings. The insulation, electrical cables, plumbing and any other services required in external walls must be installed and inspected by the building consent authority before starting the installation of internal linings. The internal lining and services must be installed in accordance with their manufacturer's product literature and comply with the NZBC requirements.

The claddings must be installed within 180 days after the installation of HomeRAB™ Pre-Cladding or RAB™ Board.

3.1.2 Bracing

For bracing application the HomeRAB™ Pre-Cladding and RAB™ Board must be installed as per HomeRAB™ Pre-Cladding/RAB™ Board bracing details in the Bracing Design Manual by James Hardie. Bracing with rigid air barriers can only be achieved when fixed direct to frame. The board must be fixed in accordance with the bracing details to all framing. For further information on bracing refer to Clause 6 of this installation manual or Table 14 of the Bracing Design Manual by James Hardie or call 0800 808 868.

3.1.3 Fire rated wall construction

RAB™ Board is classified as 'Non-Combustible Material'. For fire rated wall applications RAB™ Board must be installed as per the current Fire and Acoustic Design Manual by James Hardie. RAB™ Board is suitable to achieve fire ratings up to 60 minutes when installed in accordance with fire systems specifications published in the Fire and Acoustic Design Manual by James Hardie. The board must be fixed with Hardie™ Flex nails at 150mm centres to all framing.

3.2 Stud To Top Plate Fixing

Refer to Section 5.2, Figure 17 for alternative stud to top plate connection.

3.3 Seismic Deflections

RAB™ Board is suitable for use as rigid backing in buildings where the structure is designed to expect the lateral inter-storey seismic deflections. The seismic deflections can have a significant effect on the performance of the façade system and its components, therefore it is crucial to first understand the amount of inter-storey deflections and then to choose a suitable rigid air barrier and façade system that has been tested to meet the performance appraised.

James Hardie has a range of tested cladding/façade systems with RAB™ Board that are suitable for a range of seismic deflection. For further design and installation guidance, refer to clause 5.3.3 of this manual and Figure 26.

3.4 Membranes

RAB™ Board can be used for self adhesive or torch on membranes. These are dressed on the face of RAB™ Board as per adhesive or torch on membrane manufacturer's recommendations.

4 Framing and Fixings

4.1 Framing

The timber framing shall be in accordance with the NZS 3604 or comply with the specific engineering design requirements. The timber treatment must comply with the NZBC Acceptable Solution B2/AS1 requirements.

The minimum framing size required for fixing HomeRAB™ Pre-Cladding or RAB™ Board is 90 x 45mm. Ensure that the framing is suitable for installing the selected cladding. Refer to cladding installation manual for further information about the framing requirements.

When RAB™ Board used in a fire rated system by James Hardie, consult the Fire and Acoustic Design Manual by James Hardie as post fire stability may require different framing size and spacing. For specific engineering design projects where the timber framing differs from whats been provided in this manual, Ask James Hardie on 0800 808 868.

Table 4

HomeRAB™ Pre-Cladding				
Wind zone	Stud centres (max)	Nog centres (max)	Nail Spacing General	Fixing Type
Up to and including H (High)	600mm	800mm	200mm	40 x 2.8mm Hardie™ Flex nail
Very High	400mm	800mm	200mm	

Note: HomeRAB™ Pre-Cladding must not be used in EH, SED wind zones and on fire rated wall application. Use RAB™ Board instead. Bracing fixings as per the bracing information Clause 6.

Table 5

RAB™ Board 6mm and 9mm					
Facade Design Wind Pressures (ULS)	Stud centres (max)	Nog centres (max)	Fixing spacing (max)		Fixing Type
			General	Fire	
all wind zones up to 2.4kPa	600mm	To suit cladding	200mm	150mm	RAB™ Board 6mm - 40 x 2.8mm Hardie™ Flex nail RAB™ Board 9mm - 50 x 2.8mm Hardie™ Flex nail
SED wind pressure up to 3.2kPa	600mm	800mm	150mm	150mm	
SED wind pressure up to 4.5kPa	400mm	800mm	150mm	150mm	

Note: Bracing fixings as per the bracing information Clause 6

4.2 Fixings

HomeRAB™ Pre-Cladding and RAB™ Board must be installed with its sealed face towards the external cladding and unsealed face towards the framing. The sealer applied on the face helps the board to drain the moisture freely over the face and keeps it dry.

- Nails must finish flush with board surface
- Use 40 x 2.8mm or 50 x 2.8mm Hardie™ Flex nails or round head gun nails as per Table 4 or 5 above.

The HomeRAB™ Pre-Cladding and RAB™ Board are fixed as described below.

HomeRAB™ Pre-Cladding and RAB™ Board can either be gun nailed or hand nailed. It is recommended to use gun nails to cut down installation time. When gun nailing only use round head nails with minimum length of hand nail and follow nail gun manufacturer's instructions for correct operation of tool and site safety requirements.

- Nails must have a minimum clearance of 12mm from the sheet edges and a minimum of 50mm horizontally and 75mm vertically from the sheet corners
- **Do not use D-head nails**

4.3 Fastener Durability

Fasteners must have the appropriate level of durability required for the intended project to comply with the NZBC. This is of particular importance in coastal areas, areas subject to salt spray and other corrosive environments. Refer to Table 6 for information regarding the types of nails to use to comply with the durability requirements of the NZBC.

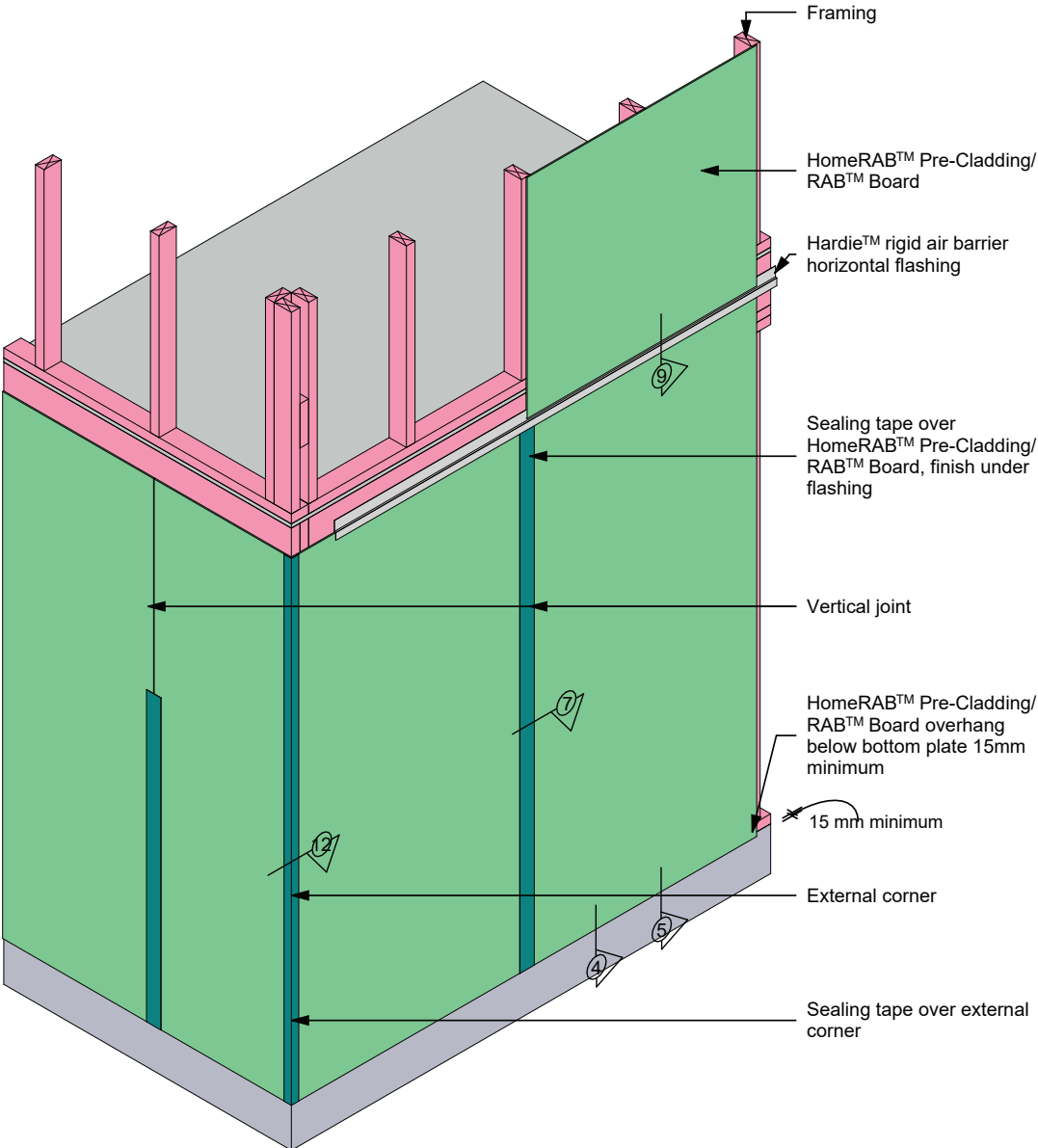
Table 6

Exposure conditions and nail selection prescribed by the NZS 3604		
Zone	Application	Nail material
D (Sea Spray) and Geothermal hot spots	General	Stainless steel 304/316
	Fire	
	Bracing	
C* and B	General	Hot dip galvanised Must comply with AS/NZ 4680
	Fire	
	Bracing	

*Where local knowledge dictates that increased durability is required use stainless steel nails

Fasteners must be fully compatible with all other materials that they are in contact with to ensure the durability and integrity of the assembly. Contact fastener manufacturers for more information. Also refer to Table C.1.1.1A and C.1.1.1B of E2/AS1 for further information about the suitable fastening materials and their compatibility with other materials.

Figure 3: HomeRAB™ Pre-Cladding and RAB™ Board layout



4.4 Clearances

HomeRAB™ Pre-Cladding and RAB™ Board must extend below the bottom plate by 15mm minimum over concrete foundation and 15mm past floor joist of timber foundation. HomeRAB™ Pre-Cladding and RAB™ Board must maintain a 100mm minimum clearance between the bottom edge of the sheet and the finished ground.

Check cladding manufacturer for minimum clearances required for the selected cladding.

Figure 4: Foundation detail – direct fix cladding

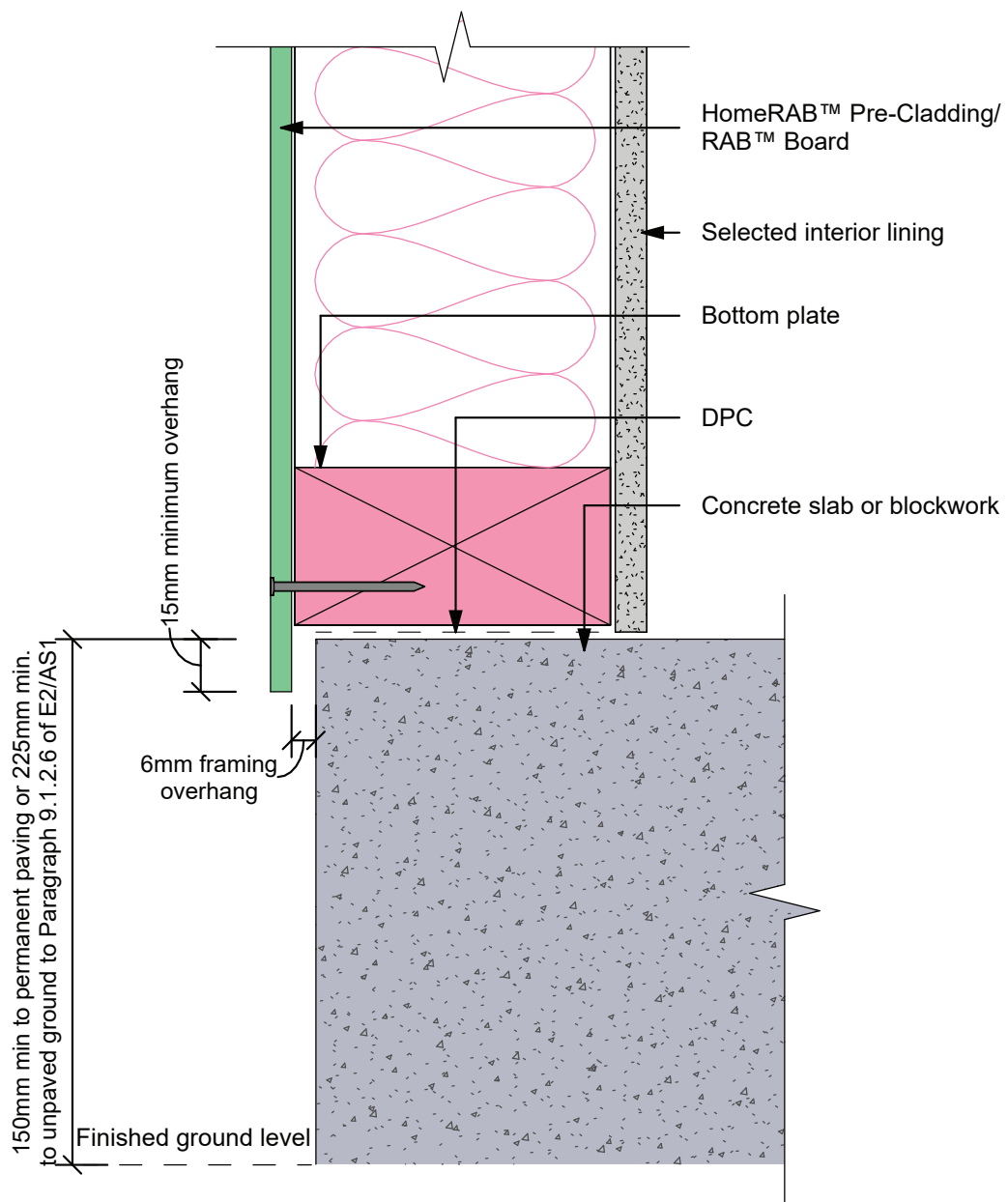
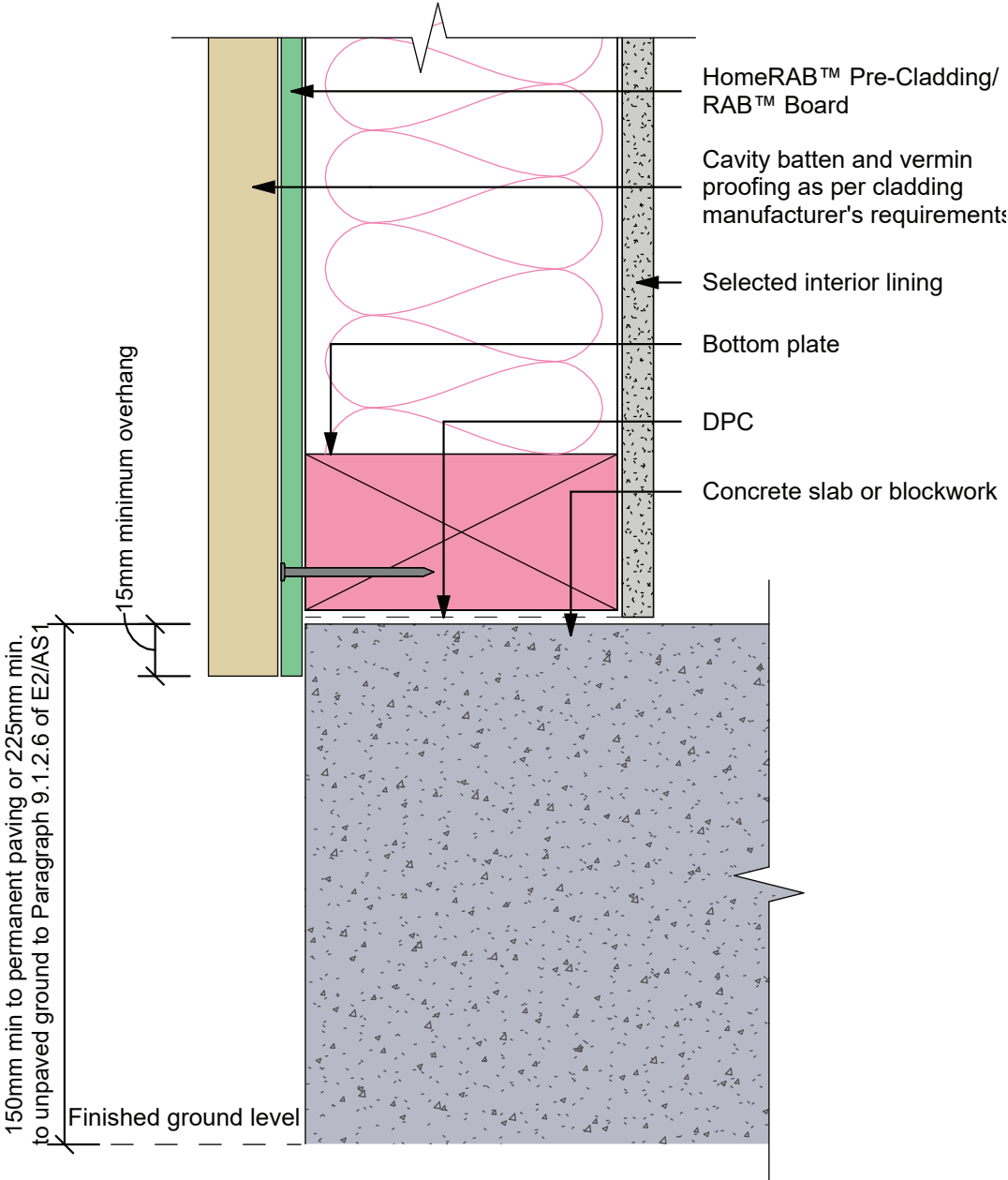


Figure 5: Foundation detail — cavity fix cladding



Maintain the required clearances between the bottom plate and top of ground to comply with the NZBC and NZ standards. The adjacent finished ground must slope away from the building in accordance with the NZBC requirements. Do not install HomeRAB™ Pre-Cladding or RAB™ Board in such a way that it may remain in contact with standing water.

Figure 6: Foundation detail – timber foundation

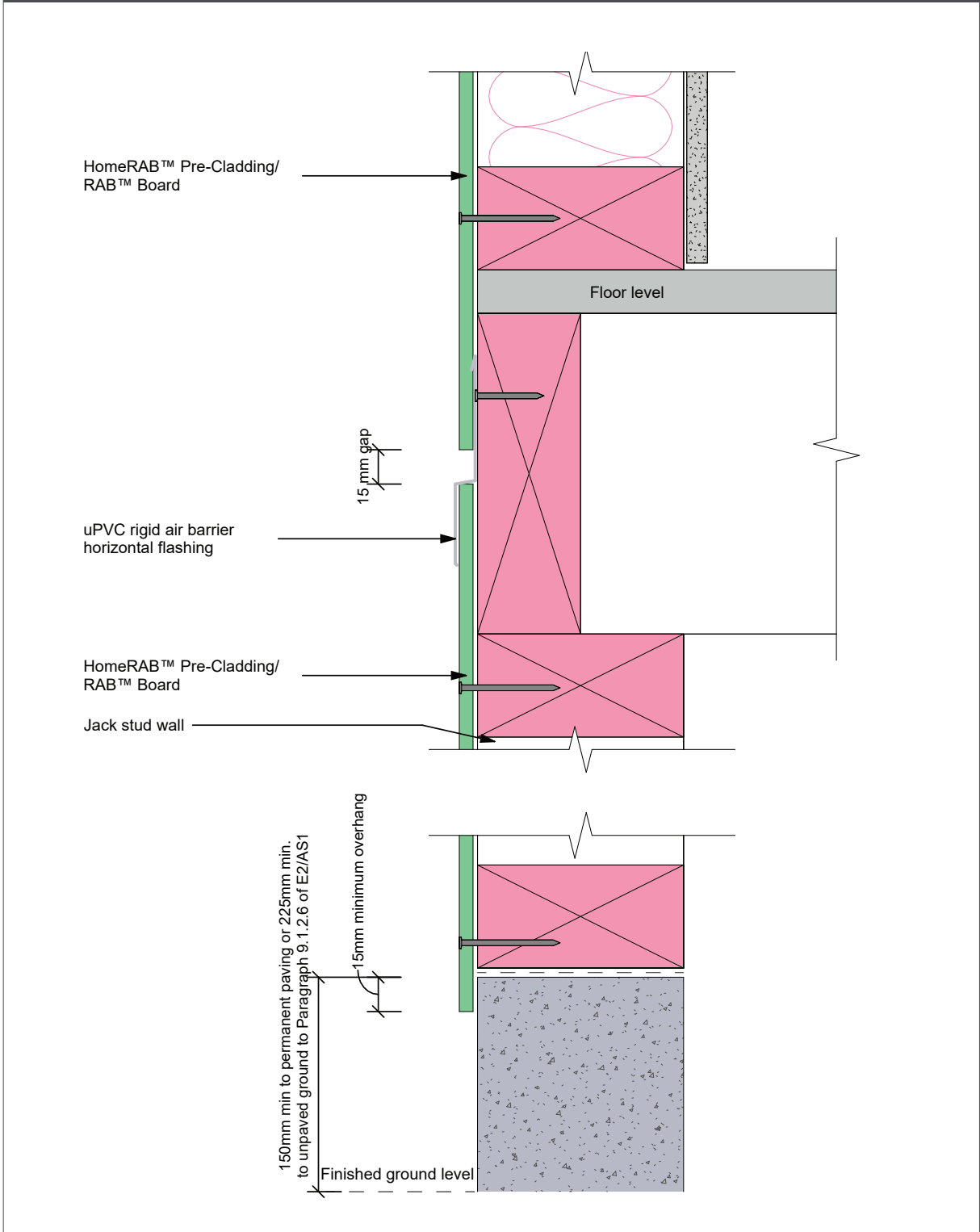
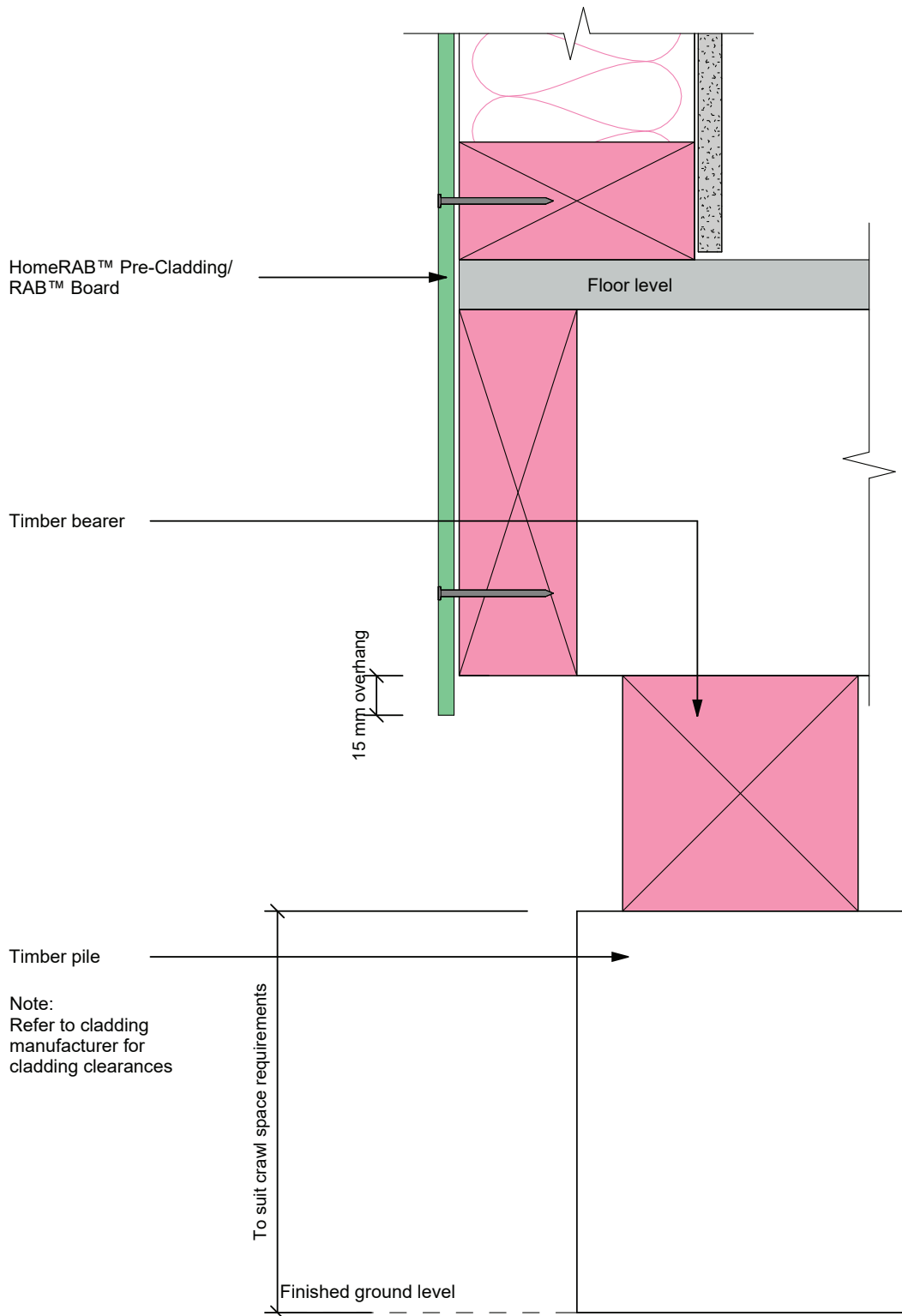


Figure 7: Foundation detail – timber pile foundation



5 Installation

5.1 Board Layout

When using HomeRAB™ Pre-Cladding or RAB™ Board, flexible underlays are not required over the framing. HomeRAB™ Pre-Cladding/RAB™ Board have been tested and comply with the performance requirements of Table C.2.1.1 of Clause E2 of the NZBC. The sheets are jointed keeping a gap of 2-4mm maximum between the sheet edges. The board must be cleaned of any dust before fixing the jointing tape over the joint.

Cut edges where exposed must be primed prior to installation with Dulux® 1 Step, Resene® Quick Dry or similar.

The bottom edge of HomeRAB™ Pre-Cladding and RAB™ Board must overhang below the bottom plate by 15mm minimum, refer to Figures 4 and 5.

5.1.1 Vertical joints

Vertical joints must be sealed to stop the moisture ingress into the framing behind HomeRAB™ Pre-Cladding/RAB™ Board. The vertical joints are sealed over by running a 75mm wide sealing tape e.g. Thermakraft™ Premium Joining Tape, SUPER-STICK Building Tape®/3M™ All Weather Flashing Tape 8067.

The sealing tapes must be pressed hard over the HomeRAB™ Pre-Cladding or RAB™ Board surface while fixing so that they achieve the required bond. The sealing tapes must not be exposed to elements for more than 180 days. This achieves the required protection when the cladding is installed. The claddings must be installed within 180 days.

Note: Refer to sealing tape manufacturers recommendations regarding the installation of their sealing tapes in cold climate conditions. It is recommended to warm up the sealing tapes such as when the air and substrate temperatures are below 10°C. Check with tape manufacturer for their recommendations

5.1.2 Horizontal joints

The horizontal joint of HomeRAB™ Pre-Cladding or RAB™ Board must be flashed using a uPVC horizontal flashing or alternatively aluminium or colour steel Z flashings can also be used. Refer to Figures 9, 10 and 11. Leave a gap of 15mm minimum at the solid timber floor joist or as specified by the project engineer. The flashing must be lapped by a 35mm minimum on both sides of the joint.

For walls longer than 3m, horizontal uPVC flashing must be lapped by 50mm minimum and silicone sealed.

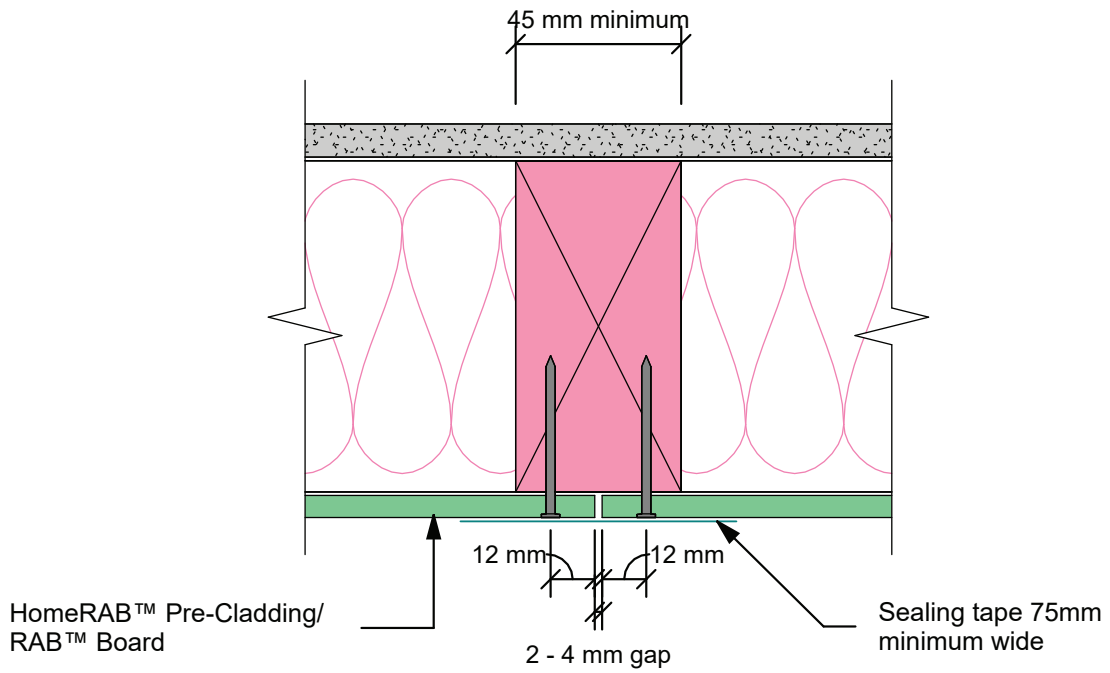
HomeRAB™ Pre-Cladding and RAB™ Board must not be fixed into floor joists.

5.1.3 Internal/external corners

All corner joints of HomeRAB™ Pre-Cladding and RAB™ Board must be sealed using a 75mm minimum wide sealing tape.

When using a uPVC horizontal flashing in horizontal joints, the internal and external corner flashing joints must be sealed using a 75mm minimum wide joint sealing tape. Refer to Figures 14a, 14b and 14c.

Figure 8: Vertical joint



5.1.4 Flexible underlay

HomeRAB™ Pre-Cladding and RAB™ Board can also be used in conjunction with flexible underlay in accordance with Part 9 of E2/AS1. When installing HomeRAB™ Pre-Cladding and RAB™ Board as per E2/AS1 requirements, the vertical joint does not require to be sealed with flashing tapes, but the horizontal joints must be flashed using the uPVC horizontal flashing. The flexible underlay must comply with Table C.2.1.1 of E2/AS1. The wall openings must be flashed in accordance with E2/AS1 and this installation manual.

Figure 9: Horizontal joint flashing - tall wall

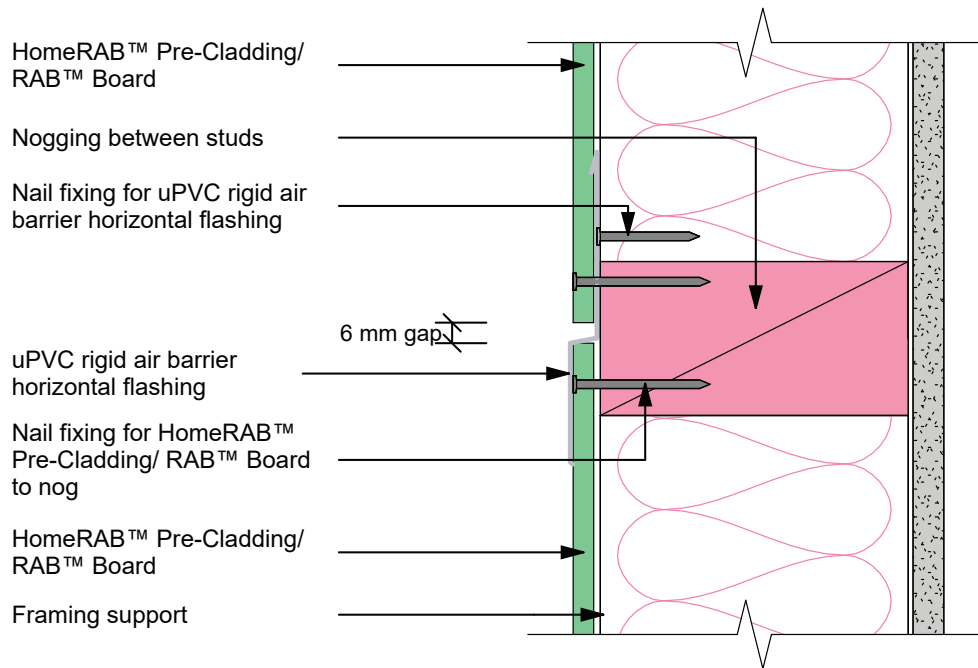


Figure 10: Horizontal joint/flashing - floor joist

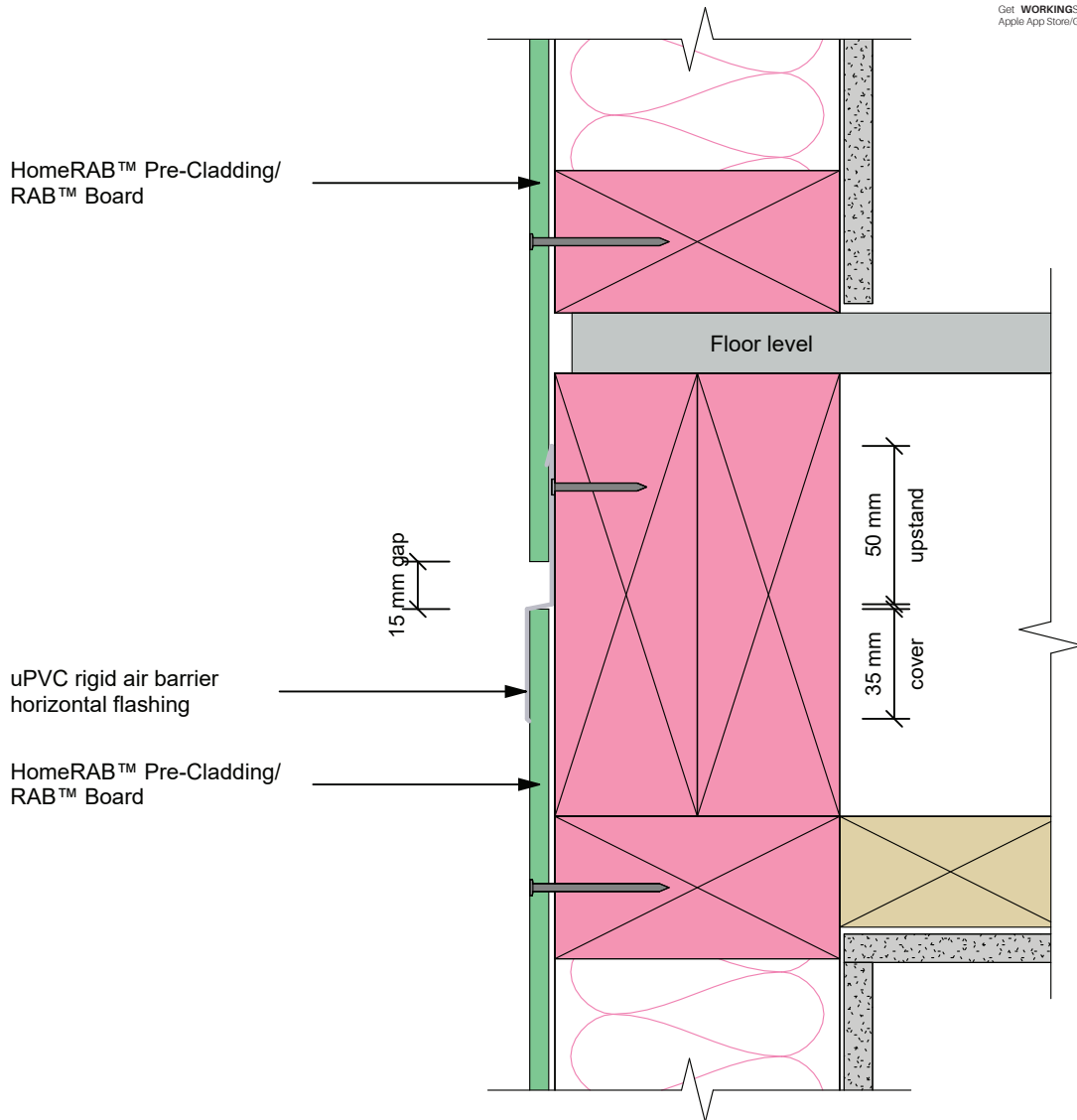


Figure 11: Horizontal joint flashing - concrete beam

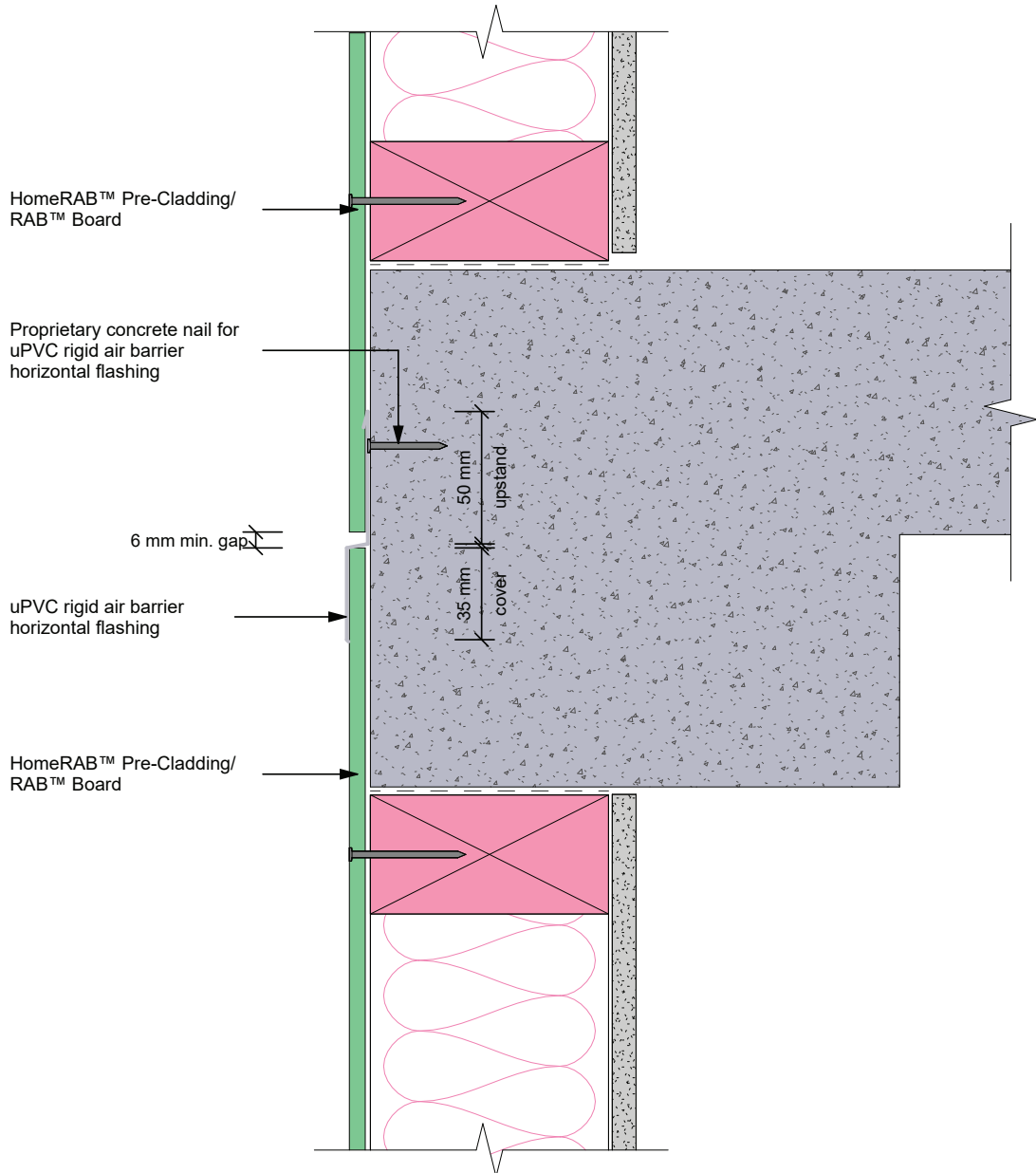


Figure 12: Internal corner joint

Interactive assembly
instructions available
<http://wksp.nz/jh-rab-inc>



Get **WORKINGSPEC** from
Apple App Store/Google Play

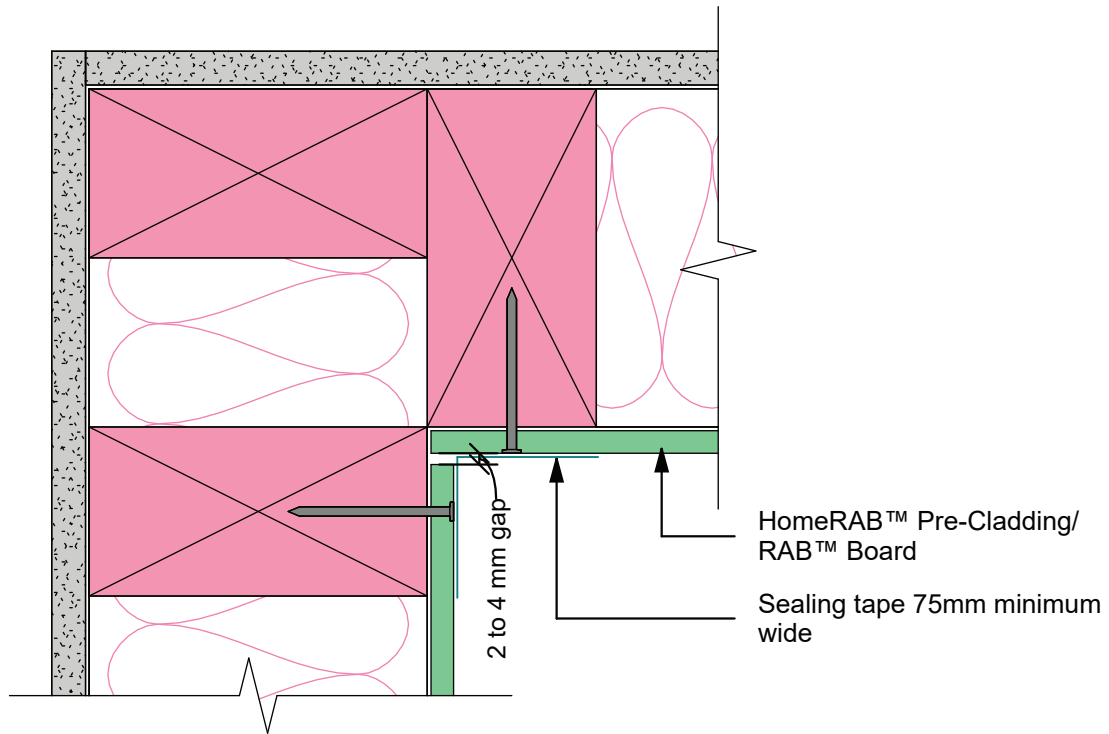


Figure 13: External corner joint

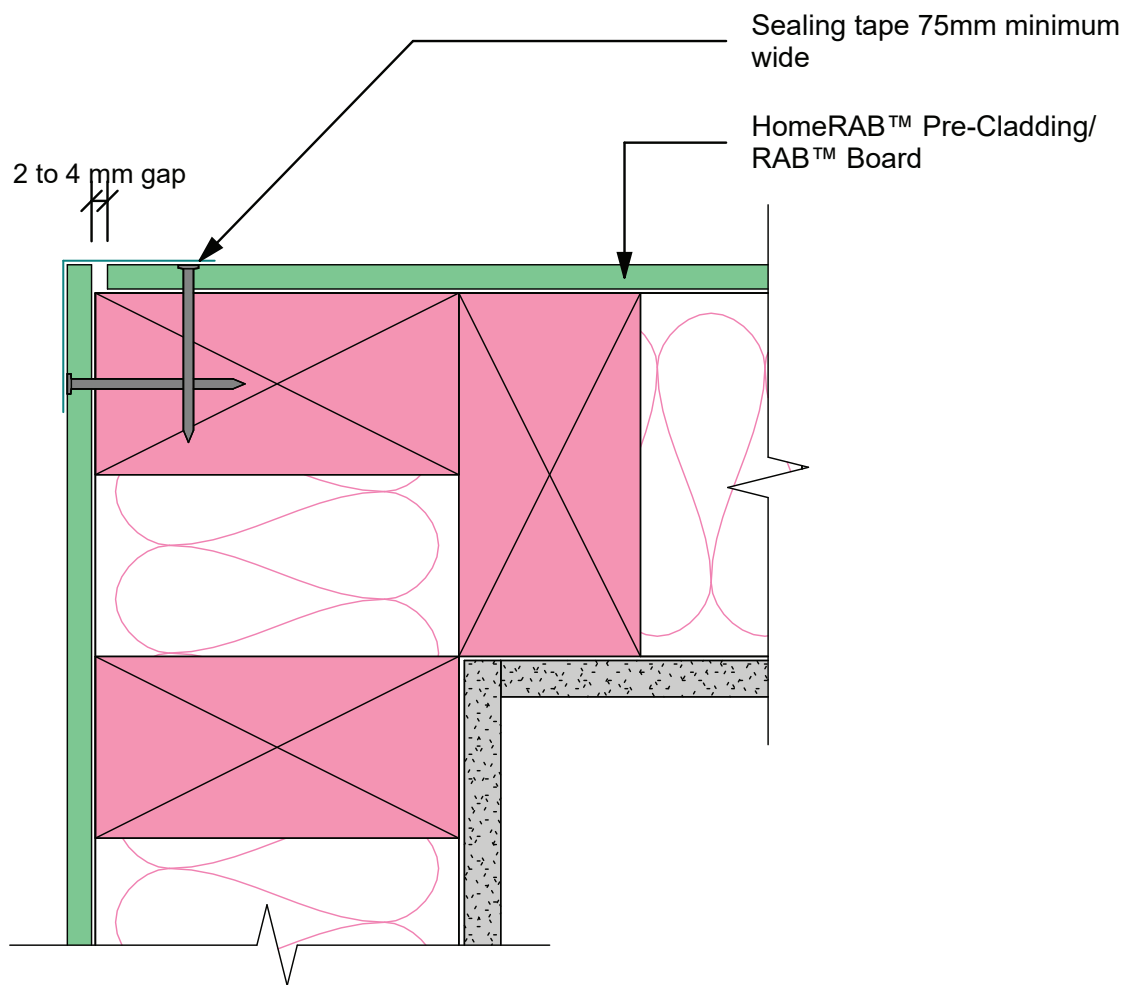
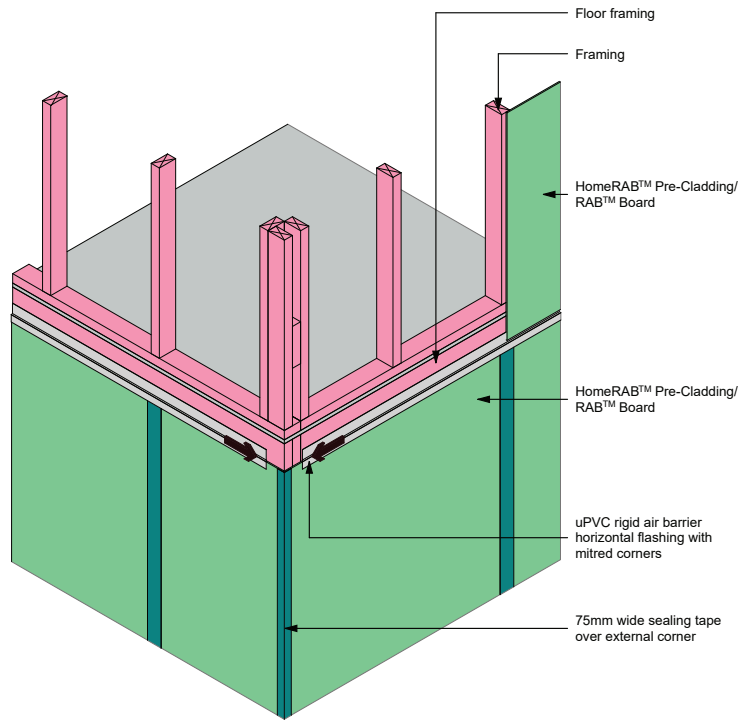


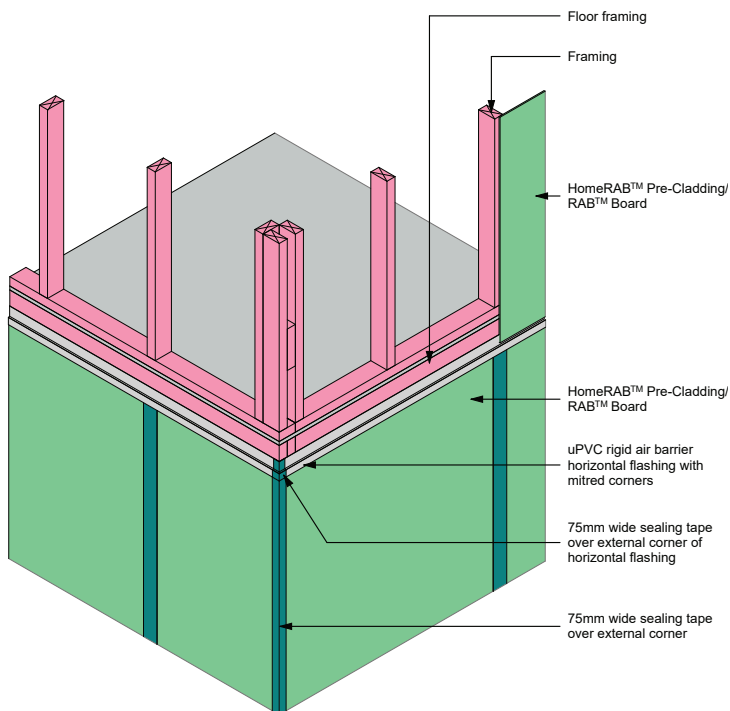
Figure 14a: Corner junction to horizontal joint



Interactive assembly instructions available
<http://wksp.nz/jh-rab-mfi>

Get WORKINGSPEC from Apple App Store/Google Play

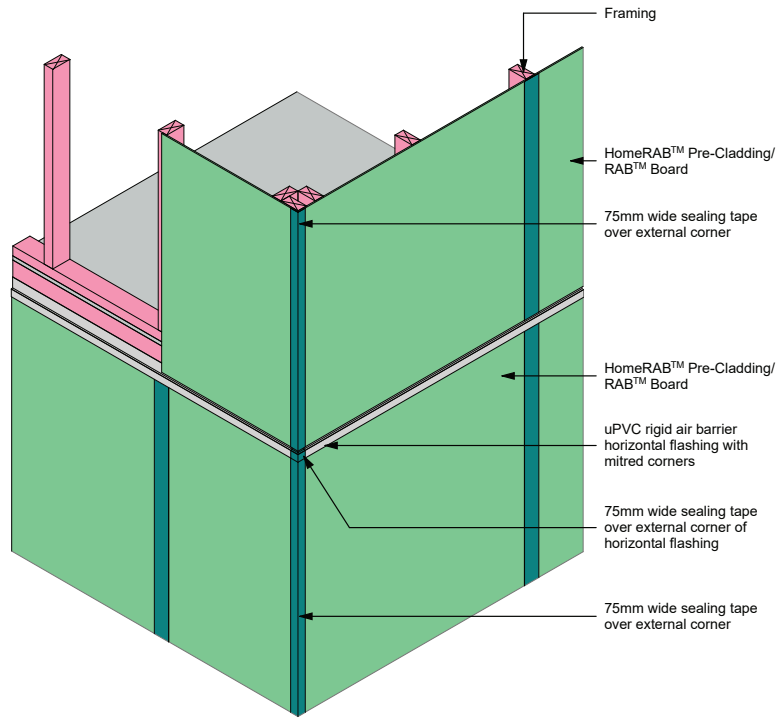
Figure 14b: Corner junction to horizontal joint



Interactive assembly instructions available
<http://wksp.nz/jh-rab-mfi>

Get WORKINGSPEC from Apple App Store/Google Play

Figure 14c: Corner junction to horizontal joint



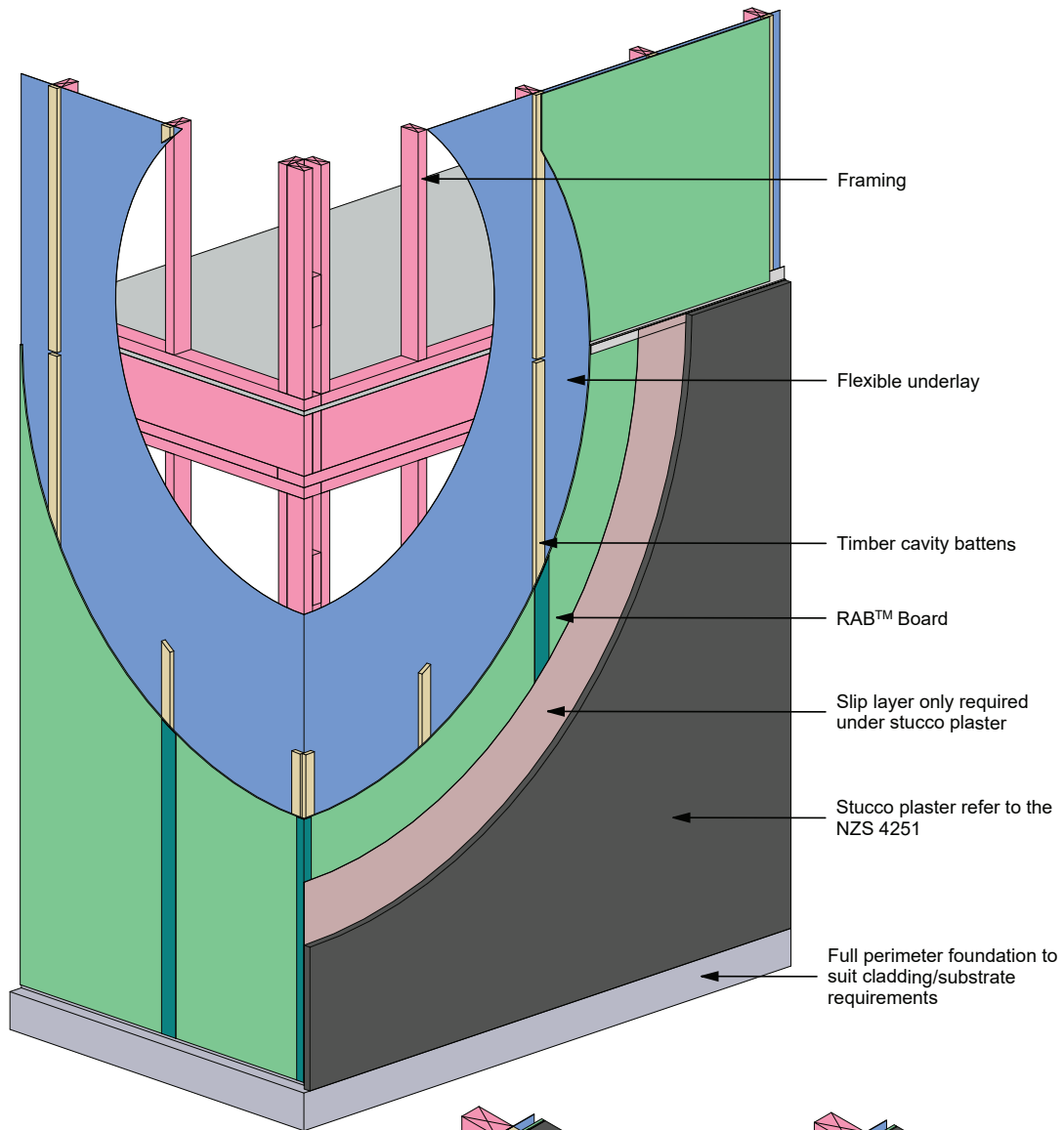
Interactive assembly instructions available

<http://wksp.nz/jh-rab-mf>



Get WORKINGSPEC from Apple App Store/Google Play

Figure 15: RAB™ Board used as backing board for stucco plaster or stacked stone cladding systems



Note:
Accessories and installation details as per the stucco plaster/stacked stone provider

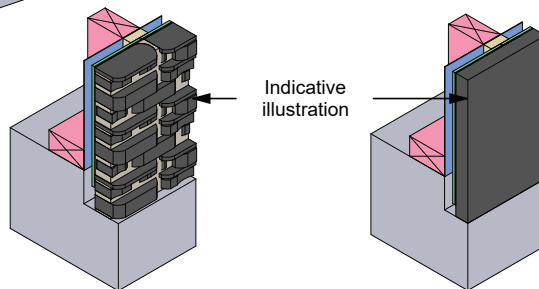
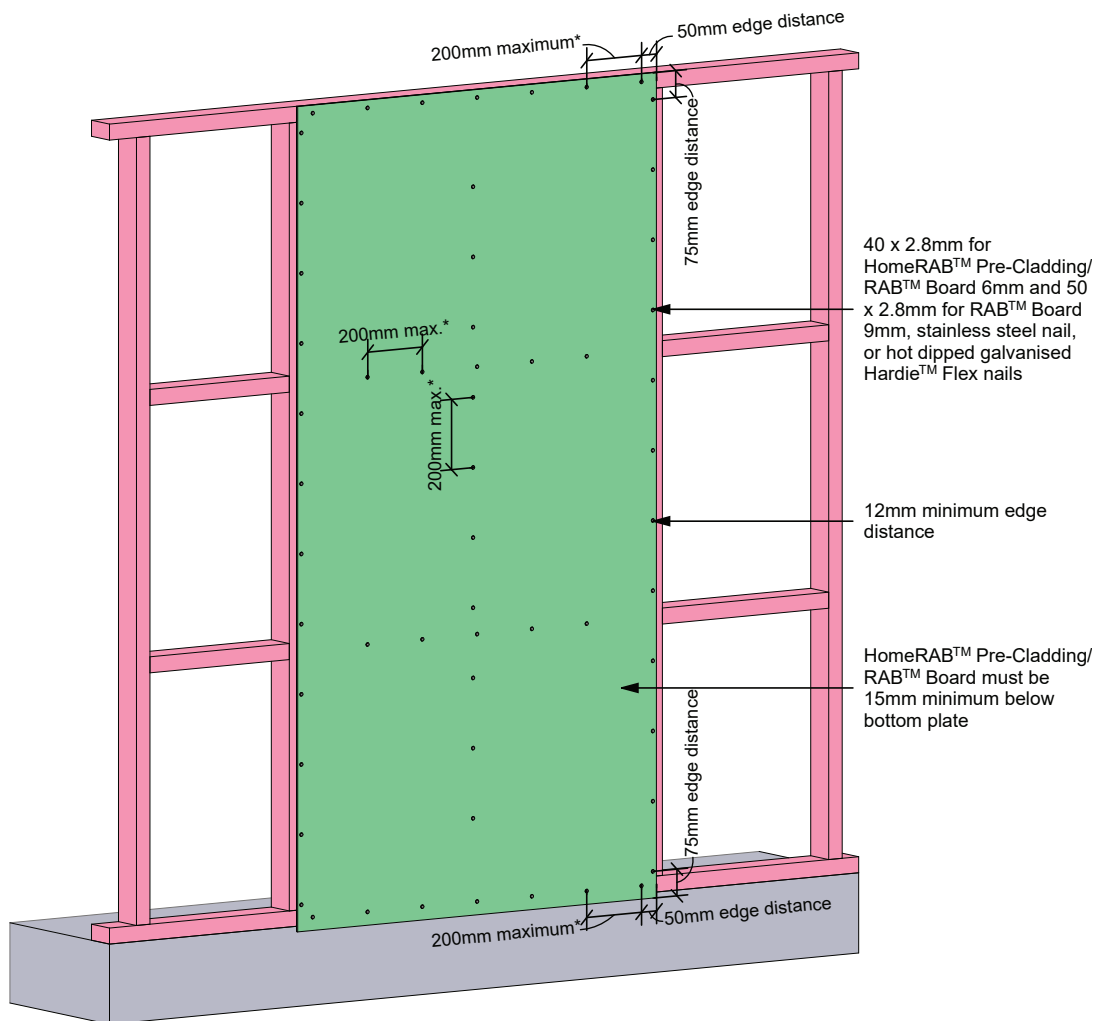


Figure 16: Sheet Fixing - General Application



Important notes:

- * For bracing the board must be fixed at 150mm centres to the entire framing with hand nails or at 100mm centres to the entire framing with gun nails.
- For fire rated wall applications and/or SED projects more than 1.5kPa the RAB™ Board must be fixed at 150mm centres to the entire framing with hand or gun nails
- Where a double top plate is used, the truss fixing should be continuous through the double top plate

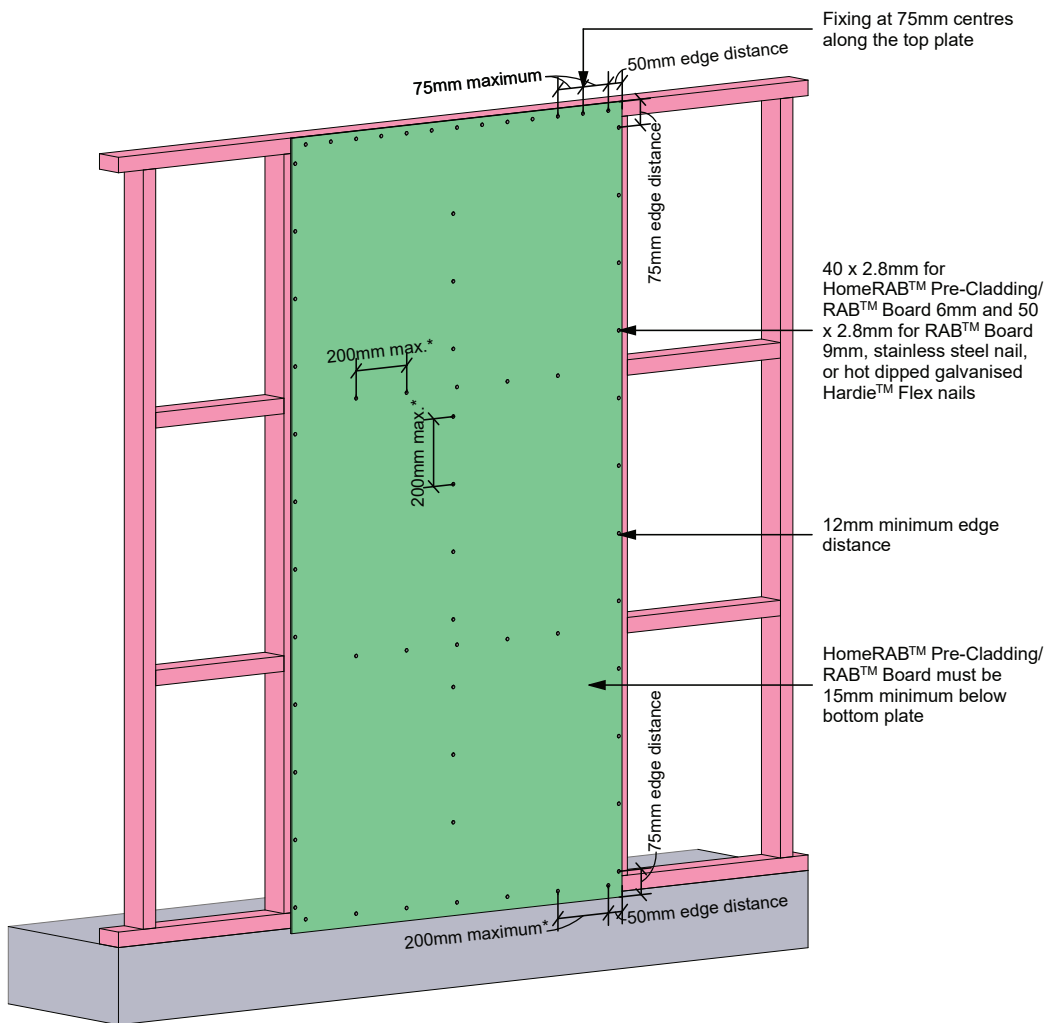
5.2 Stud To Top Plate Fixing

Table 8.18 of the NZS 3604 specifies two types of fixings i.e. Type-A with a fixing capacity of 0.7kN and Type-B with a fixing capacity 4.7kN. HomeRAB™ Pre-Cladding and RAB™ Board have been tested and are verified as suitable alternatives to achieve the required stud top plate connectivity as mentioned above and no special use of straps/plates or wire dogs etc. is required.

For a 0.7kN connectivity, the standard fixing of HomeRAB™ Pre-Cladding and RAB™ Board using 40 x 2.8mm Hardie™ Flex nails at 200mm centres maximum will achieve this.

For a 4.7kN connectivity, fix HomeRAB™ Pre-Cladding or RAB™ Board using 40 x 2.8mm Hardie™ Flex nails or gun nail at 75mm centres maximum to top plate with a minimum edge distance of 20mm. Refer to Figure 17.

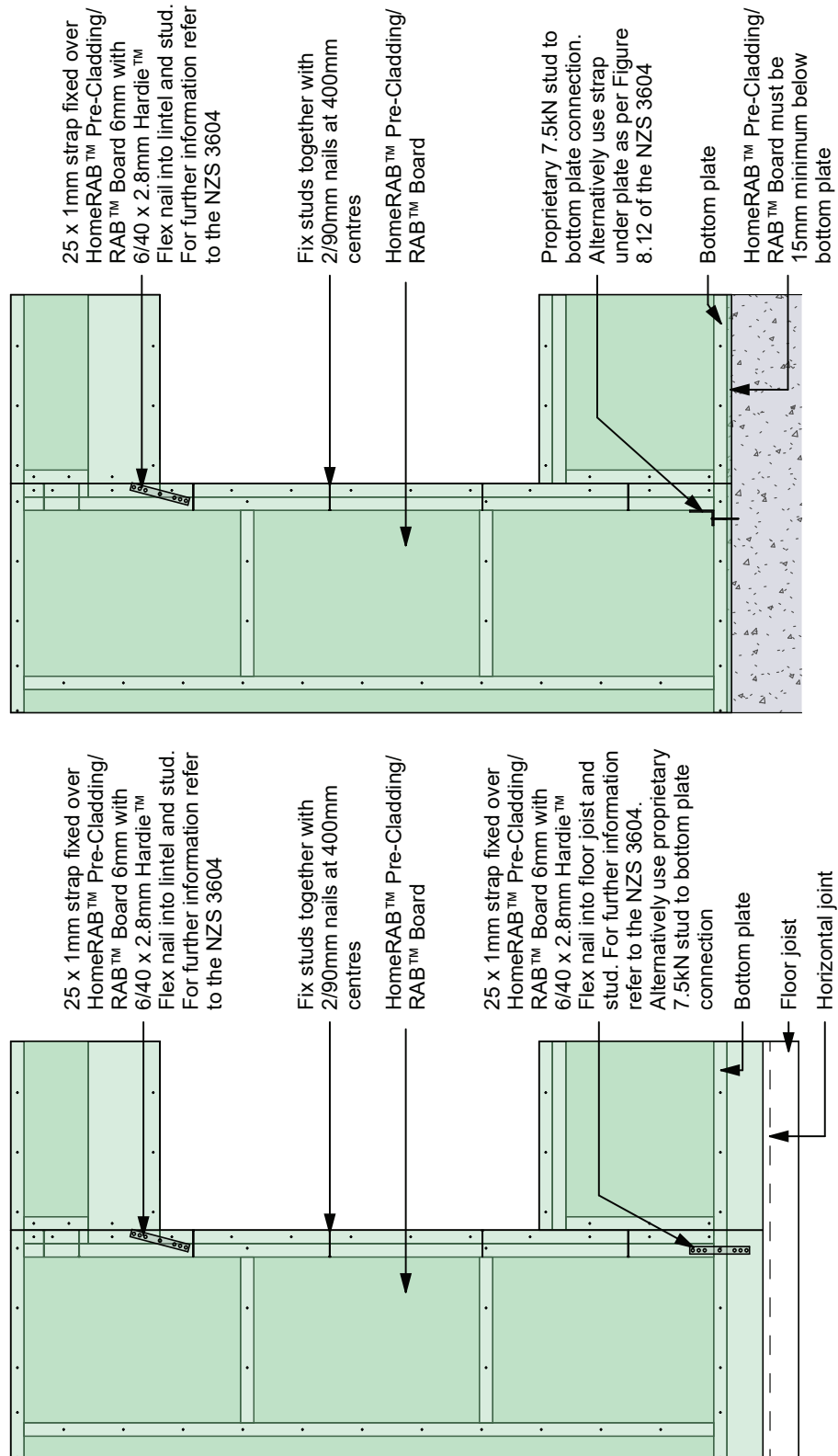
Figure 17: Stud to top plate connection



Important note:

- * For bracing the board must be fixed at 150mm centres to the entire framing with hand nails or at 100mm centres to the entire framing with gun nails.
- For fire rated wall applications and/or SED projects more than 1.5kPa the RAB™ Board must be fixed at 150mm centres to the entire framing with hand or gun nails

Figure 18: Alternative lintel strap fixing

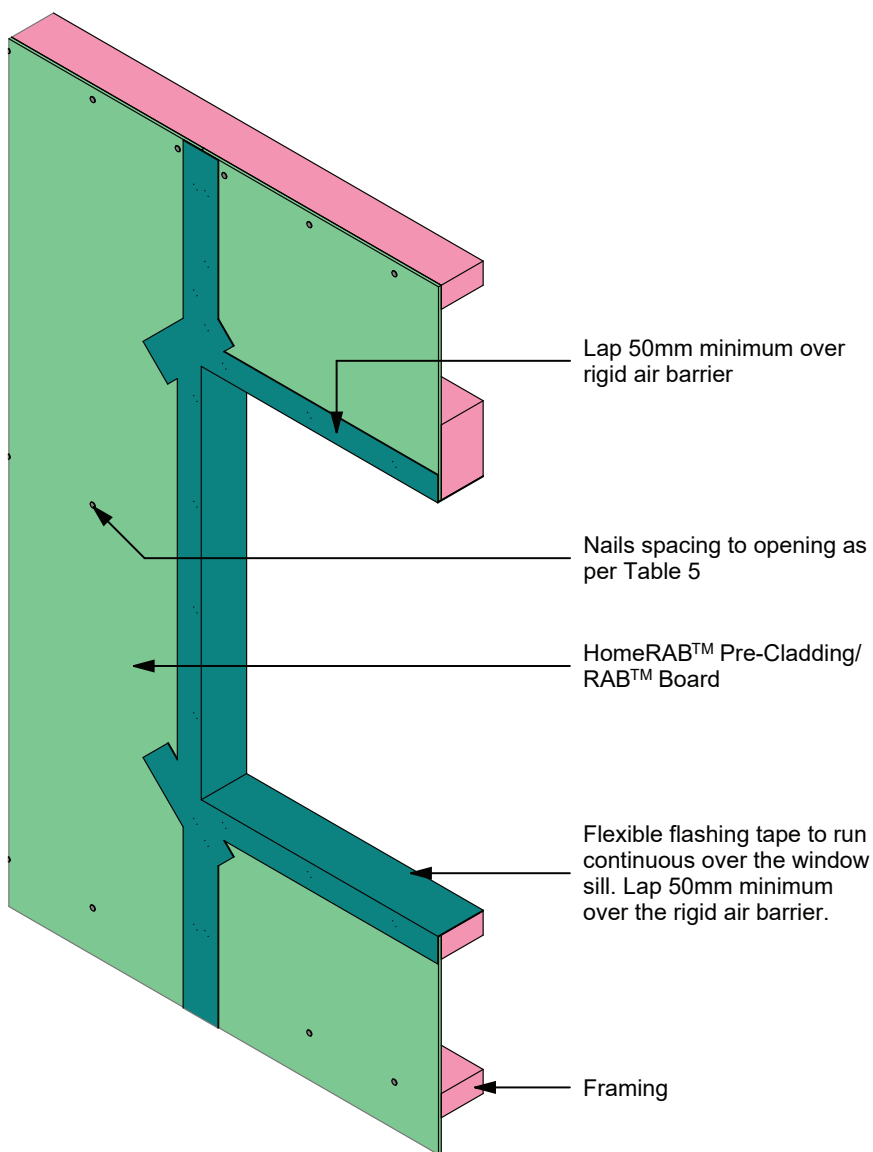


5.3 Flashings

The exposed timber framing around the window jamb can be covered with a 150mm minimum wide flashing tape or a sealing tape refer to Figures 19 and 20. The window sill must be dressed with a 150mm minimum wide flashing tape. The tape is sealed over the face of the HomeRAB™ Pre-Cladding or RAB™ Board.

The HomeRAB™ Pre-Cladding or RAB™ Board surface must be clean, free of grime and dry before the tapes are applied. Some tape manufacturers require a primer tak spray be applied before fixing the tapes to the board surface to achieve a better tape adhesion. Check with the tape manufacturers for further information regarding minimum requirements etc.

Figure 19: Window sealing with flashing tapes



Notes:

- Flexible flashing tape must be applied in accordance with the tape manufacturers specifications
- Flexible flashing tape must be applied to the entire window opening

Figure 20: Window jamb with flashing tape

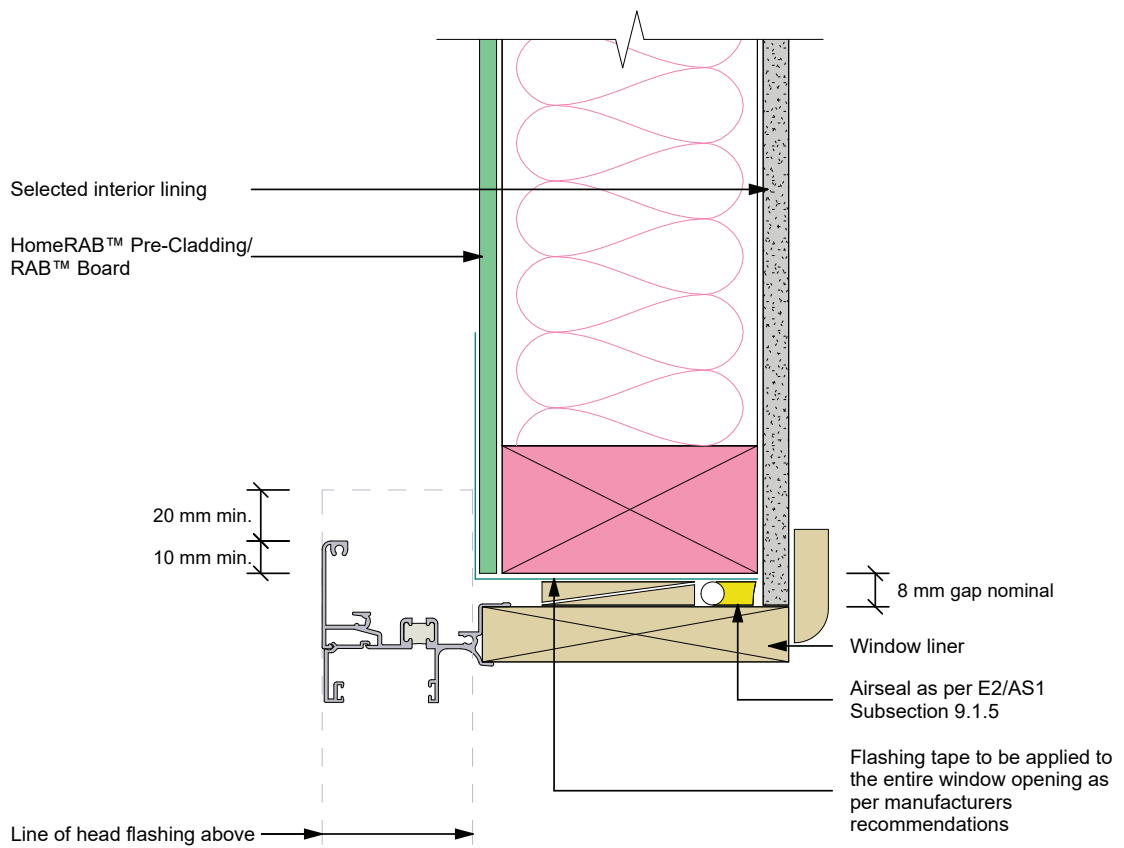


Figure 21: HomeRAB™ Pre-Cladding or RAB™ Board to standard soffit

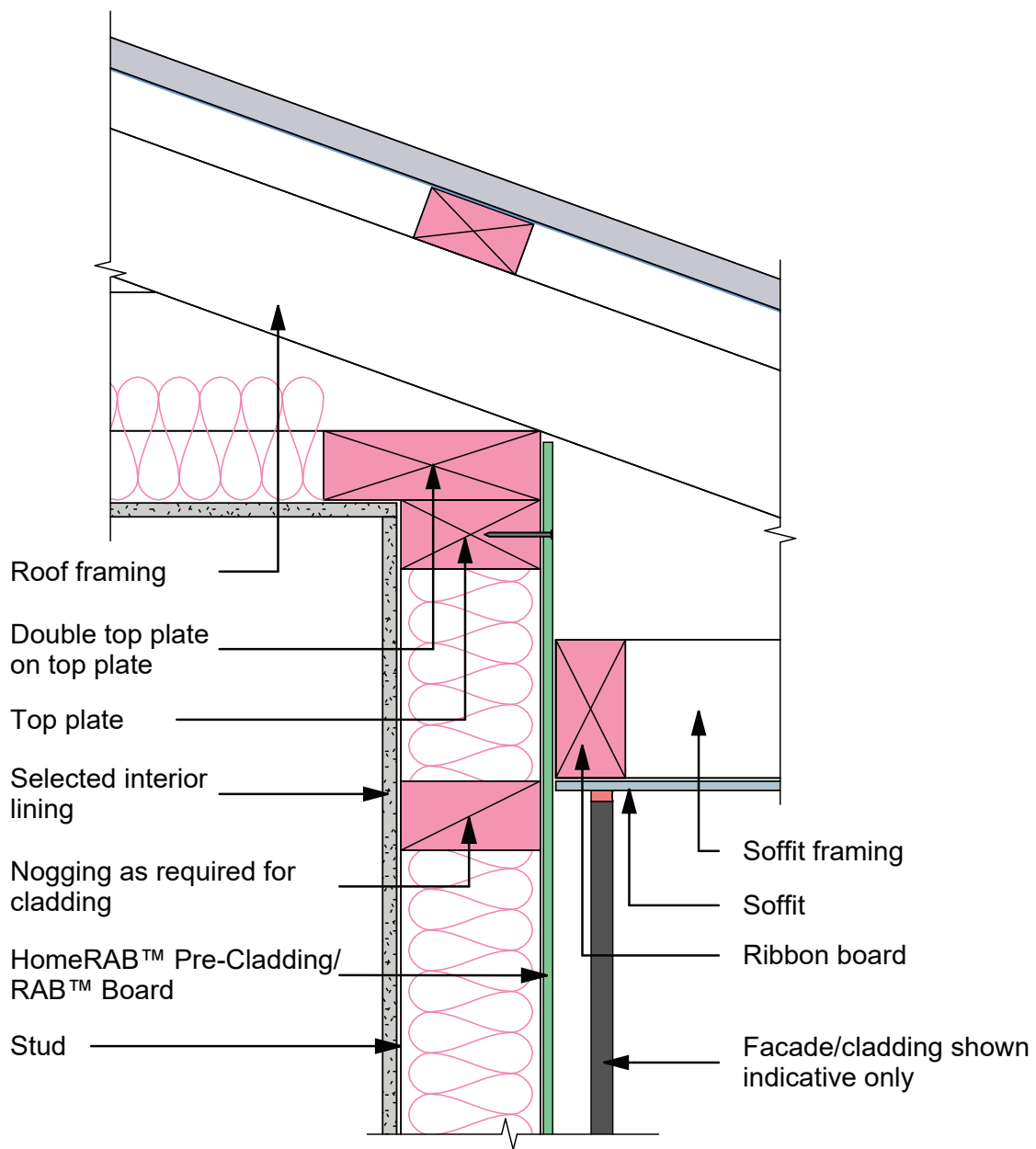
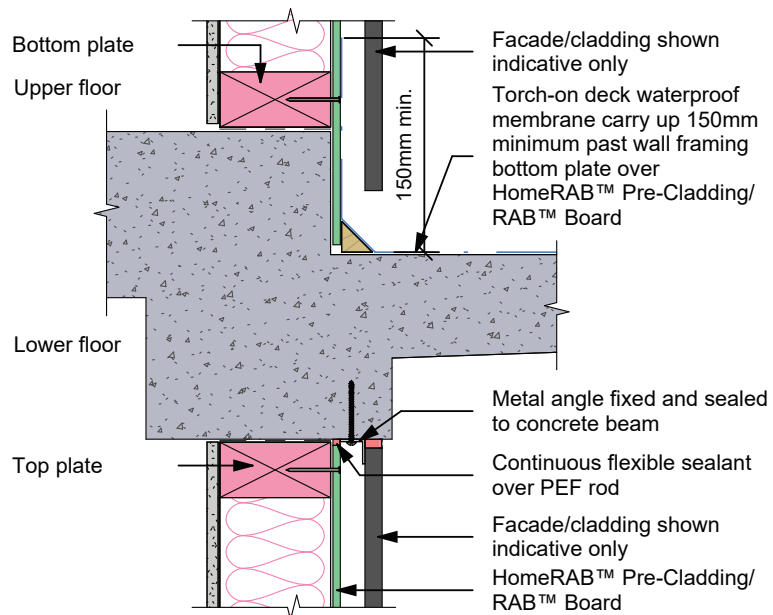
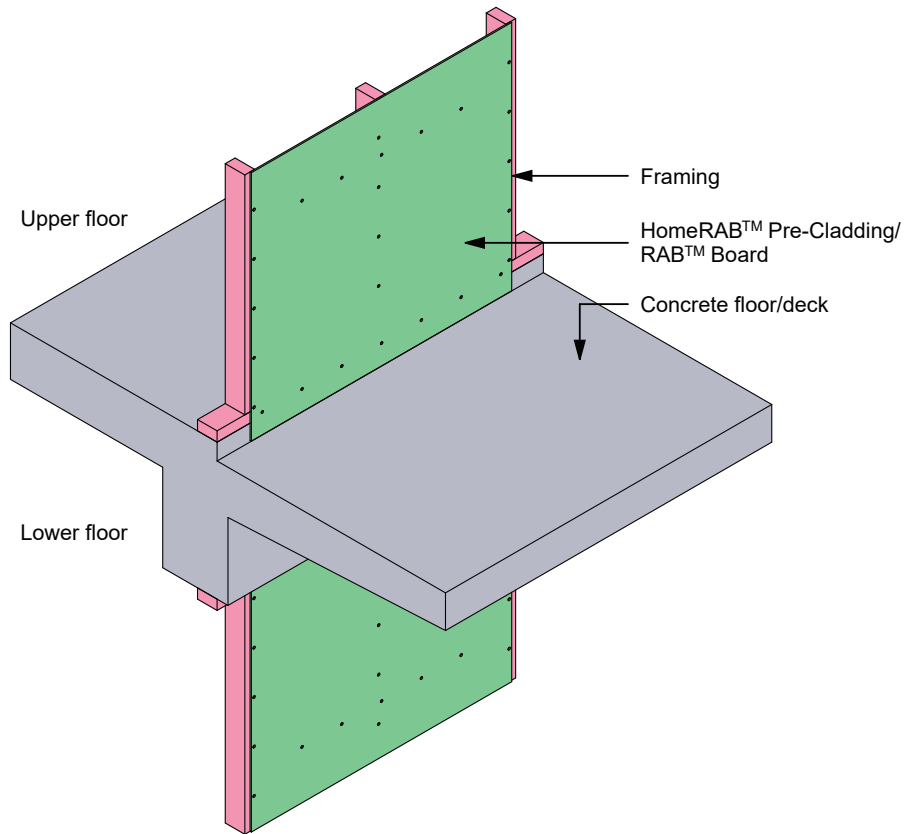


Figure 22: RAB™ Board to concrete slab junction



Important note:

- Refer to Facade/cladding manufacturer for clearances

5.3.1 Penetrations

The pipe penetrations through HomeRAB™ Pre-Cladding and RAB™ Board must be sealed securely using a flexible flashing tape. Maintain a 100mm minimum cover of flashing over the board around the penetration.

5.3.2 Balustrade to wall junctions

The junctions between balustrades to wall should be appropriately flashed. Refer to E2/AS1 of the NZBC for information and flashing details.

Figure 23: Pipe penetration through HomeRAB™ Pre-Cladding and RAB™ Board

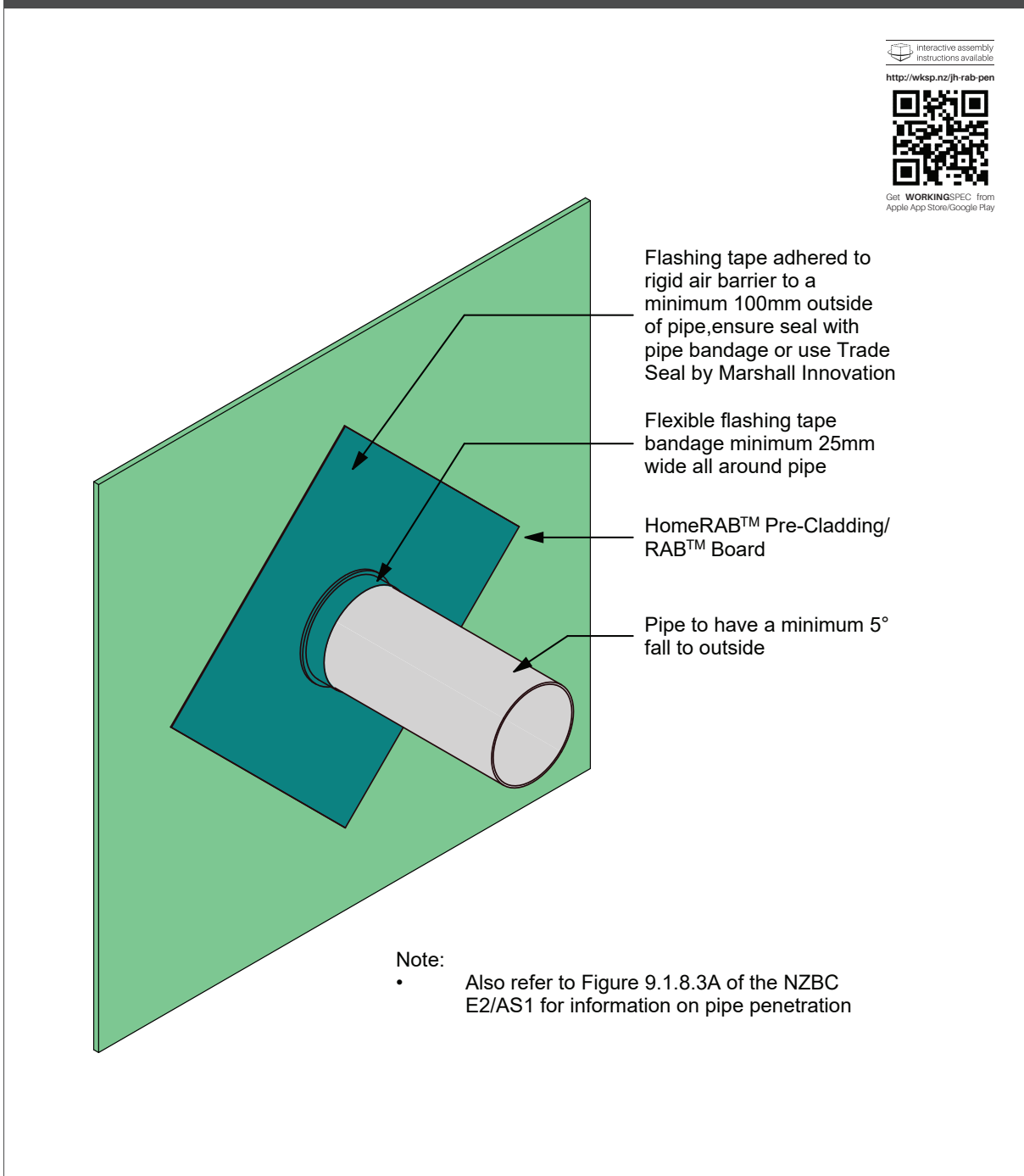
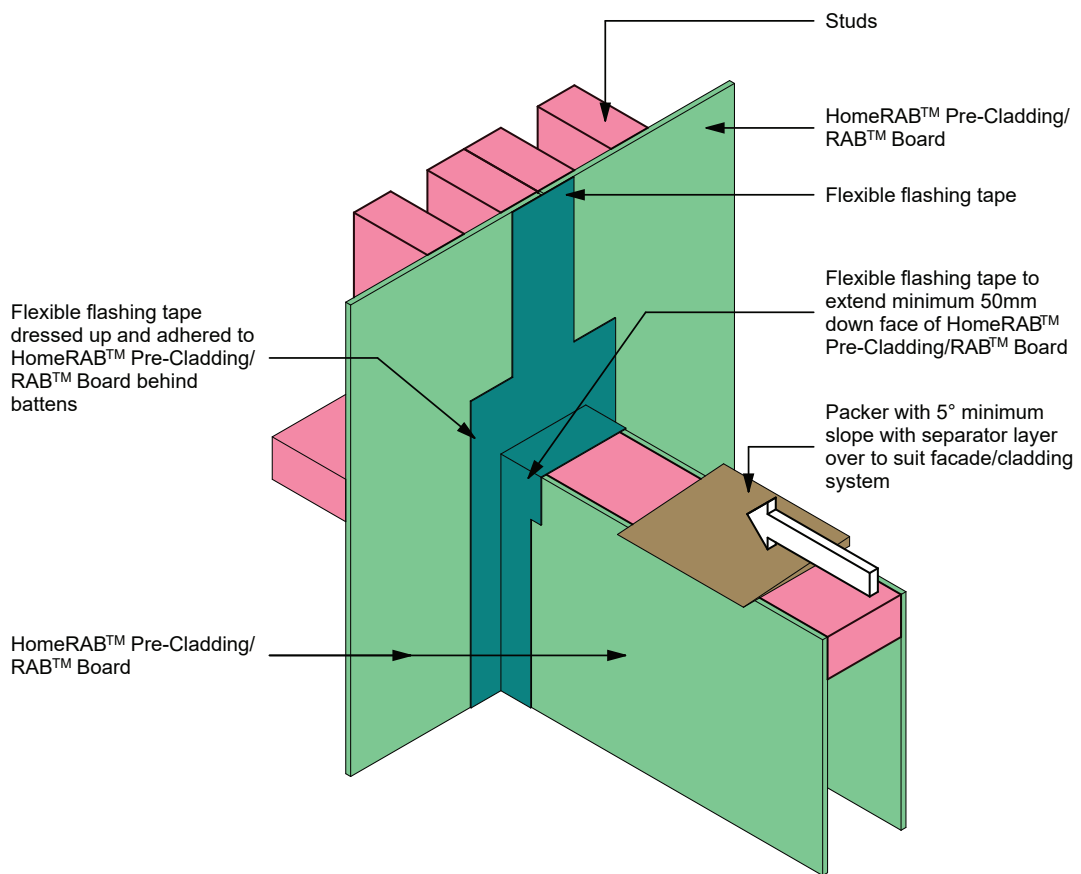


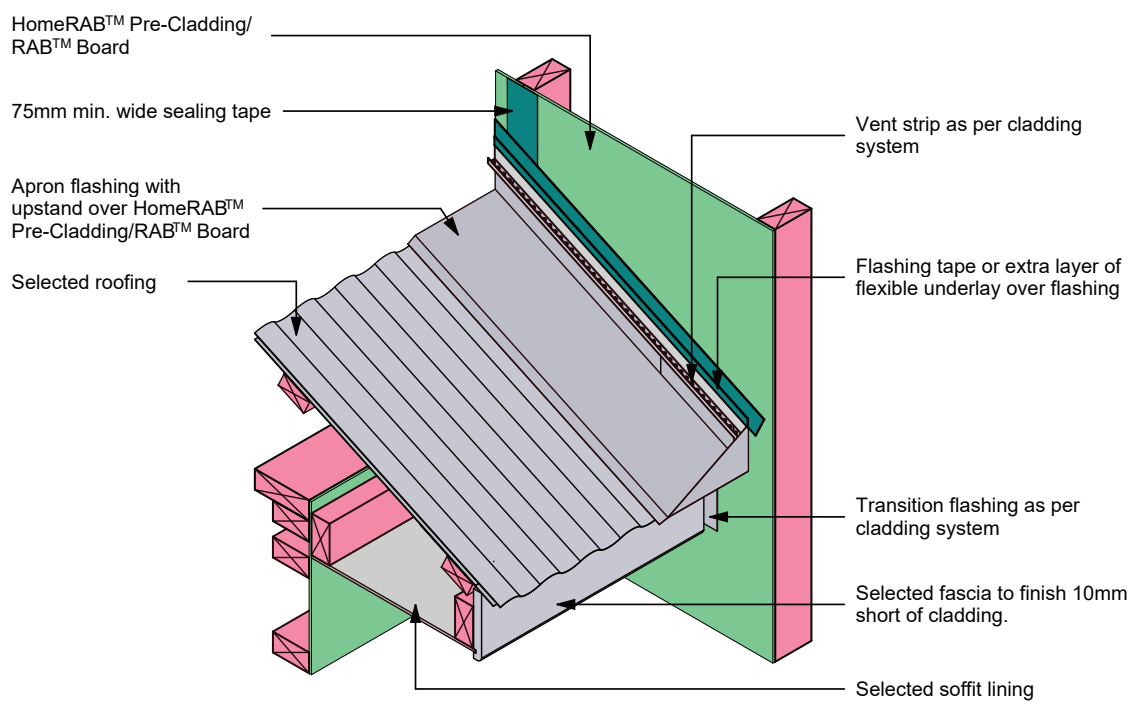
Figure 24: Flashing at balustrade



Note:

- Refer to Figure 6.2.3.1B of E2/AS1 of the NZBC for further information regarding weathertightness
- Also refer to facade/cladding manufacturer's details

Figure 25: Apron flashing



Note:

- Spouting omitted for clarity. End of spouting must be 10mm minimum clear of cladding
- Refer to cladding manufacturer for installation and details of cladding

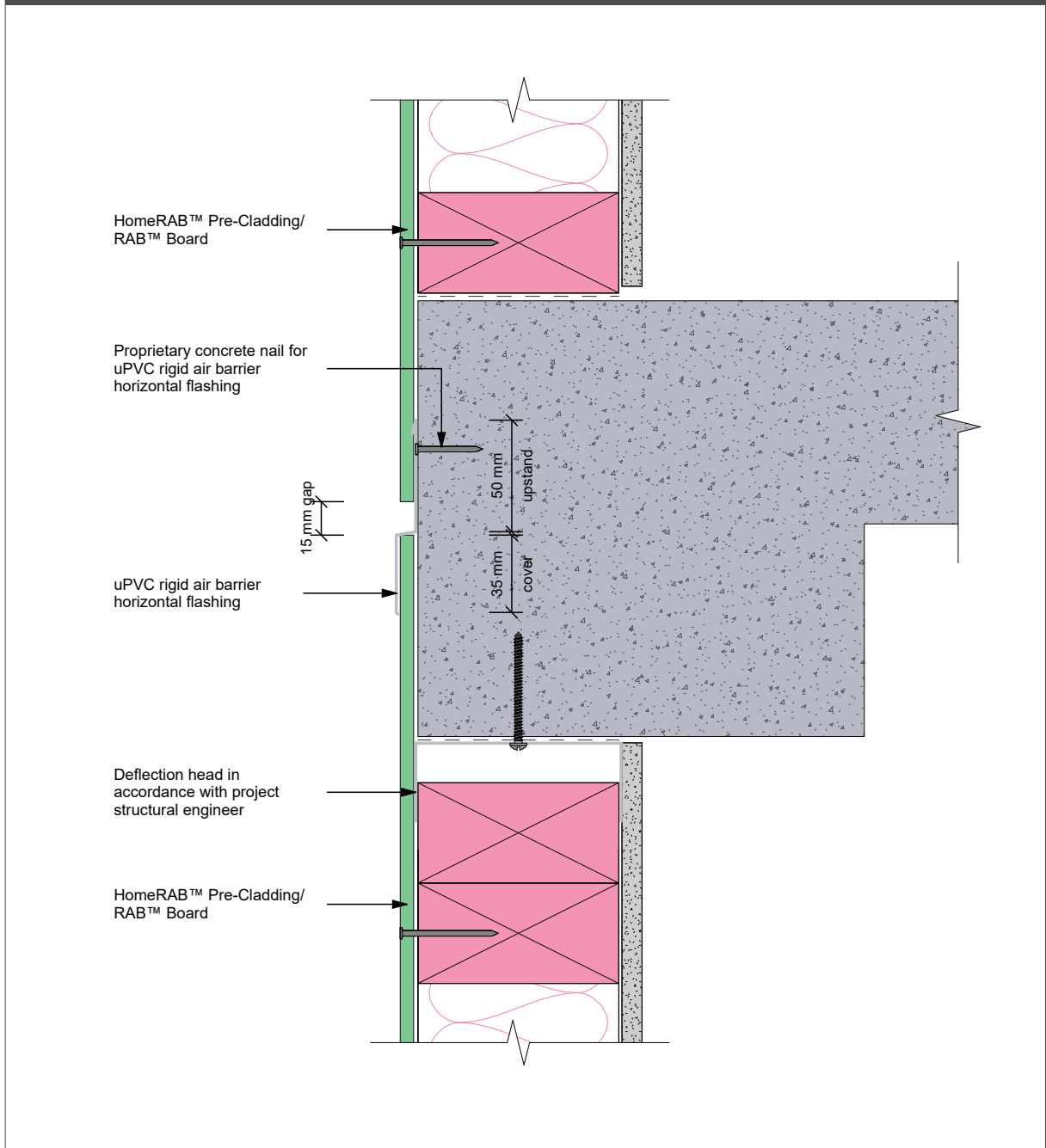
*When 50 year durability for flashing is required refer to Table 20 of the NZBC E2/AS1 document

5.3.3 Inter-storey deflections

When installing HomeRAB™ Pre-Cladding or RAB™ Board, a horizontal joint must be incorporated between sheets at each floor level to accommodate for the inter-storey deflections. Refer to Figures 10 and 11.

For the specific engineering design (SED), where structures are subject to high wind pressures and designed with inter-storey seismic deflections, the use of 6mm or 9mm RAB™ Board is recommended. RAB™ Board, when fixed as per this installation manual, is readily capable of withstanding Serviceability Limit State (SLS) deflections up to span/180. For structures where greater inter-storey seismic deflections are expected, a deflection head should be used, as per the project structural engineer's design and detailing. Refer to Figure 26.

Figure 26: Deflection head



6 Bracing

HomeRAB™ Pre-Cladding and RAB™ Board are suitable for bracing applications. Given below are various bracing systems that have been tested and the bracing values published. Refer to bracing system details for bracing installation or refer to James Hardie Bracing Design Manual for further information.

6.1 Bottom Plate Fixing/Hold Down Restraints

The timber framing must be fixed in accordance to Table 8.19 of the NZS 3604. Additional hold down restraints must be provided as per each bracing system's requirements. Refer to bracing systems details.

6.1.1 Concrete foundation

Pydra brace anchor kits or GIB® Handibrac® with a 15kN minimum uplift capacity holding down bolt can be used as end restraints.

6.1.2 Timber foundation

Pydra brace anchor kits or GIB® Handibrac® with a M12 x 150mm holding down bolt can be used as end restraints. Alternatively, holding down straps as per the NZS 3604 can also be used.

6.2 Fastener Durability and Size

Coach screws and holding down (HD) bolts, where used, must be M12 hot-dipped galvanised steel fitted with 50 x 50 x 3mm galvanised washers. The holding down bolts and washers must have a protective coating as per Table 4.2 of the NZS 3604.

Pre-Claddings:

All nails for fixing the pre-cladding bracing panels in Zone D must be Grade 304/316 stainless steel in accordance with the NZS 3604.

All nails for fixing the pre-cladding bracing panels for Zone B and Zone C can be Grade 304/316 stainless steel or hot dipped galvanised steel nail.

Note: Fastener sizes are given in the respective details section for each product or system.

6.3 Sheet Nailing

Nails can be hand driven or gun nailed at a minimum edge distance as shown in the bracing details within this specification. This also applies to dimensions from corners, vertically and horizontally. The sheets must be held hard against the framing during nailing to minimise sheet break-out at the back of sheet. Always drive all nails flush with the sheet surface. For sheet/panel systems do not punch the nail below the surface as it reduces the nail's holding power.

Fix all sheets from the centre working towards outer edges to avoid drumminess. Fixings at 150mm maximum centres when hand nailing.

Gun nails can be used on some bracing systems with fixings at 100mm maximum centres. Must use a 6.85mm Ø round head coil nail with a pneumatic nail gun. **Refer to bracing tables for hand or gun nail options available.**

6.4 Sheet Orientation

For the bracing systems specified in this manual, all flat sheets must be fixed vertically as per the bracing systems details.

Full-height sheets must be used for walls up to 2750mm for HomeRAB™ Pre-Cladding or 3000mm for RAB™ Board in height. When bracing walls height exceed HomeRAB™ Pre-Cladding or RAB™ Board tallest manufactured sheet, sheet jointing is acceptable. Only one horizontal sheet joint is permitted within the element height. The maximum height of bracing wall is limited to 4800mm.

A site cut bracing sheet must be minimum 300mm wide when used in a bracing element.

Always ensure that the sheet joint is on the centre line of the stud or nog to achieve sufficient cover of fixings.

In internal walls the lining sheet used for bracing must stop 6mm above the finished floor.

6.5 Service Penetrations

Holes/penetrations up to 100 x 100mm positioned no closer than 200mm of the edge or another penetration, are allowed for services. Maximum of two service penetrations are recommended per sheet.

No window/door penetrations are allowed within the bracing elements.

Figure 27: Penetrations in Bracing Sheet

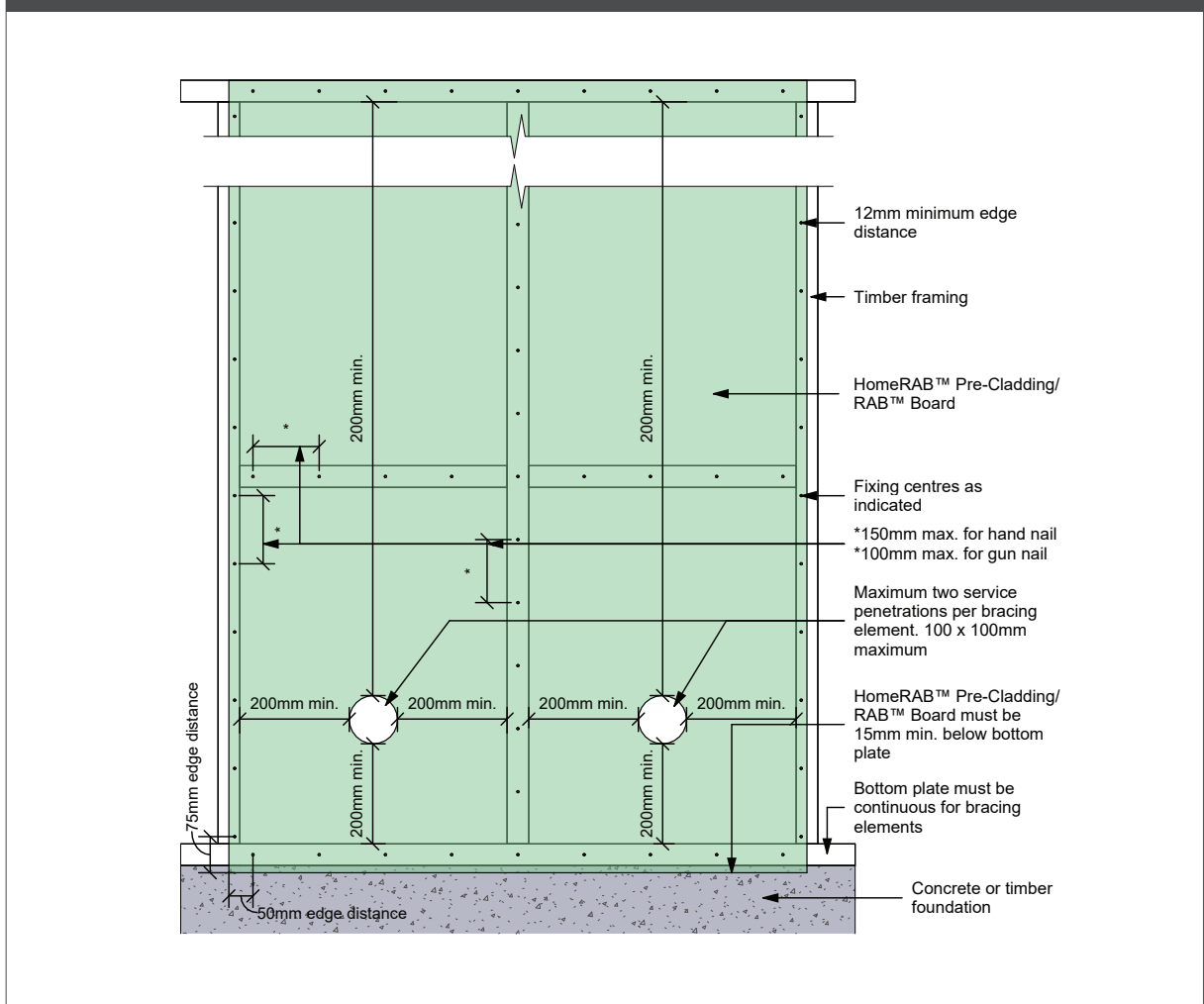


Table 7

HomeRAB™ Pre-Cladding vertically fixed									
System number	Length	Hold down	Refer figures	BU/M		kN/m		Fixing method	
				Wind	Earthquake	Wind	Earthquake	Hand nail	Gun nail
HPn	1200	N	28	67	71	3.3	3.5	√	✗
HP	400	Y	29, 37, 38, 39	85	91	4.2	4.5	√	E
	600	Y	29, 37, 38, 39	99	103	4.9	5.1	√	E
	1200 to 2400	Y	30, 37, 38, 39	133*	104	6.6	5.2	√	E
	2400 to 4800	Y	30, 37, 38, 39	141*	67	7.0	3.3	√	E

*A limit of 120BUs/m maximum applies to timber floors and 150BUs/m maximum to concrete floors built as per the NZS 3604: 2011 unless a specific engineering design is carried out to ensure the uplift force generated by bracing elements does not exceed the maximum limit for each floor type.

Table 8

HomeRAB™ Pre-Cladding vertically fixed with 10mm GIB® Standard plasterboard									
System number	Length	Hold down	Refer figures	BU/M		kN/m		Fixing method	
				Wind	Earthquake	Wind	Earthquake	Hand nail	Gun nail
HPg	400	Y	29,31,37,38,39	90	98	4.5	4.9	√	E
	600	Y	29,31,37,38,39	127*	136*	6.3	6.8	√	E
	1200 to 2400	Y	30,34,37,38,39	164*	138*	8.2	6.9	√	E

*A limit of 120BUs/m maximum applies to timber floors and 150BUs/m maximum to concrete floors built as per the NZS 3604: 2011 unless a specific engineering design is carried out to ensure the uplift force generated by bracing elements does not exceed the maximum limit for each floor type.

Table 9

RAB™ Board 6mm or 9mm									
System number	Length	Hold down	Refer figures	BU/M		kN/m		Fixing method	
				Wind	Earthquake	Wind	Earthquake	Hand nail	Gun nail
JHDn	1200	N	28	118	102	5.9	5.1	√	✗
JHD	400	Y	29, 37, 38, 39	83	107	4.1	5.3	√	E & P
	600	Y	29, 37, 38, 39	99	107	4.9	5.3	√	E & P
	1200 to 2400	Y	30, 37, 38, 39	154*	140*	7.7	7.0	√	E & P
	2400 to 4800	Y	30, 37, 38, 39	133*	150*	6.6	7.4	√	E & P

*A limit of 120BUs/m maximum applies to timber floors and 150BUs/m maximum to concrete floors built as per the NZS 3604: 2011 unless a specific engineering design is carried out to ensure the uplift force generated by bracing elements does not exceed the maximum limit for each floor type.

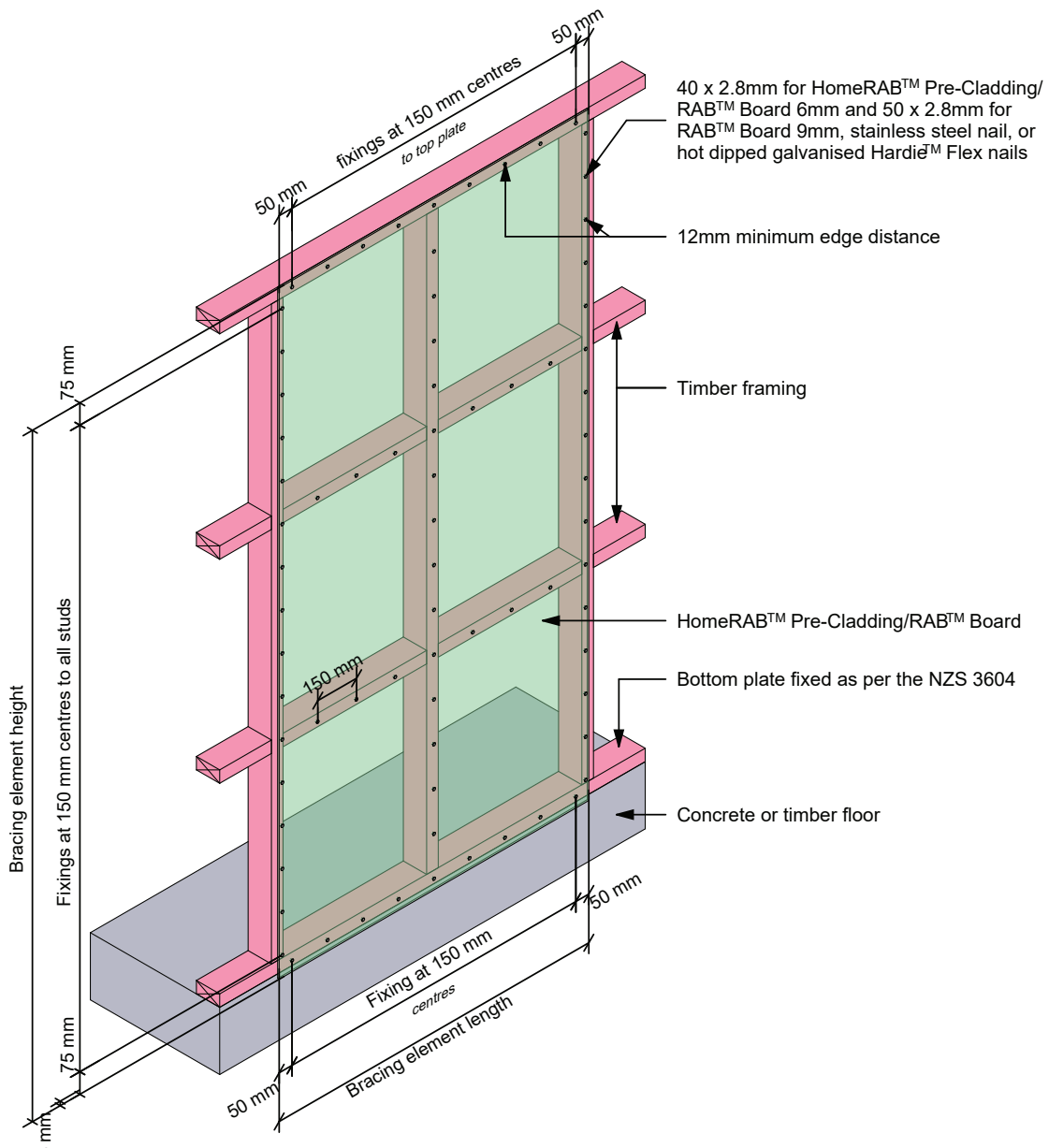
Table 10

RAB™ Board 6mm or 9mm vertically fixed with interior lining									
System number	Length	Hold down	Refer figures	BU/M		kN/m		Fixing method	
				Wind	Earthquake	Wind	Earthquake	Hand nail	Gun nail
JHDg	600	Y	29,31,37,38,39	106	121	5.3	6.0	√	E & P
JHDb	400	Y	29,32,37,38,39	94	108	4.7	5.4	√	E & P
JHDb	600	Y	29,32,37,38,39	114	127	5.7	6.3	√	E & P
JHDv	400	Y	29,33,37,38,39	82	95	4.1	3.2	√	E & P
JHDv	600	Y	29,33,37,38,39	101	124	5	6.2	√	E & P

*A limit of 120BUs/m maximum applies to timber floors and 150BUs/m maximum to concrete floors built as per the NZS 3604: 2011 unless a specific engineering design is carried out to ensure the uplift force generated by bracing elements does not exceed the maximum limit for each floor type.

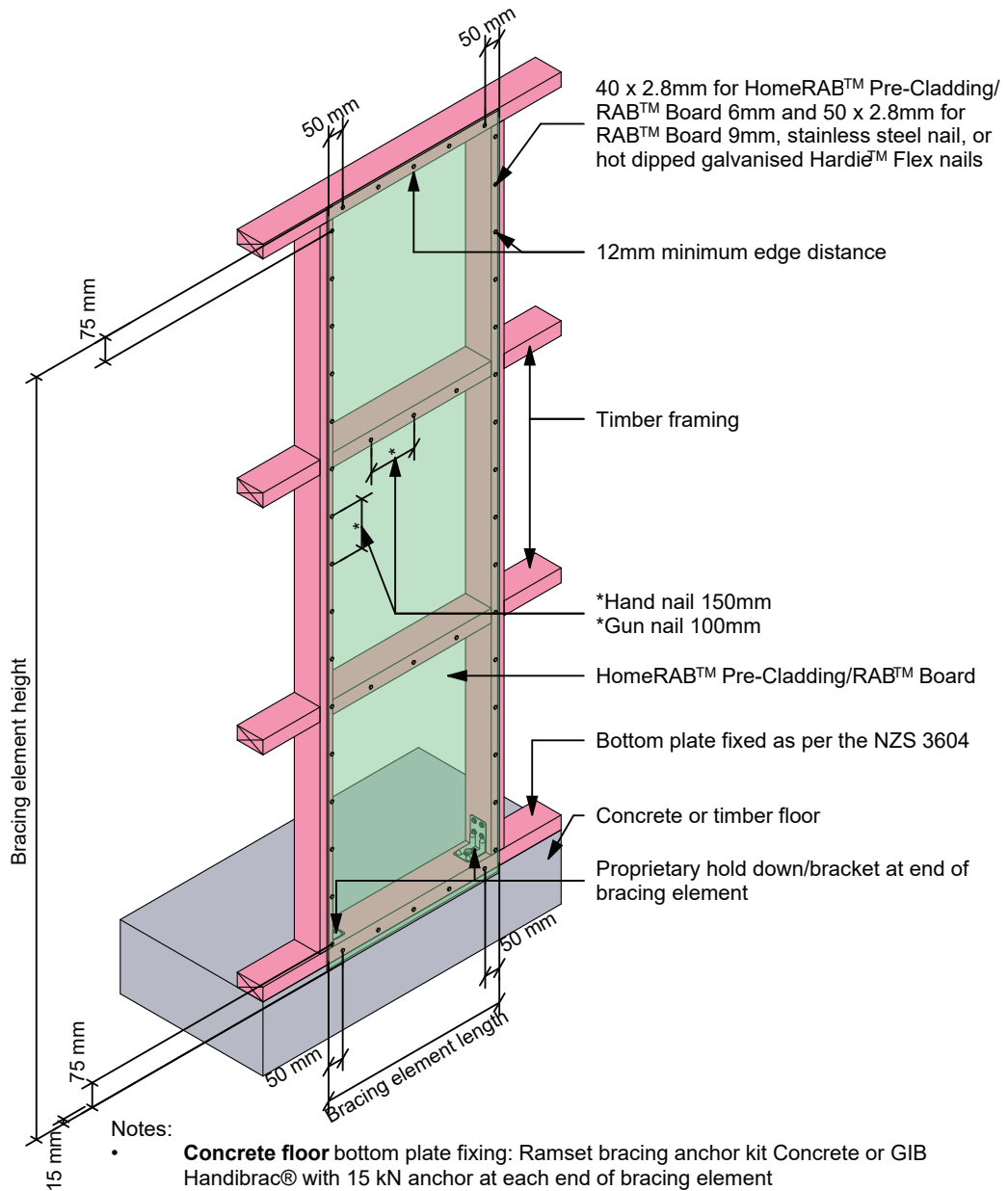
- E = Ecko® Pneumatic wireless coil nail
- P = Paslode® RounDrive ring shank nail
- g = GIB® Standard Plasterboard
- b = GIB® Braceline

Figure 28: 1200mm HomeRAB™ Pre-Cladding or RAB™ Board to concrete or timber floor - no hold down brackets



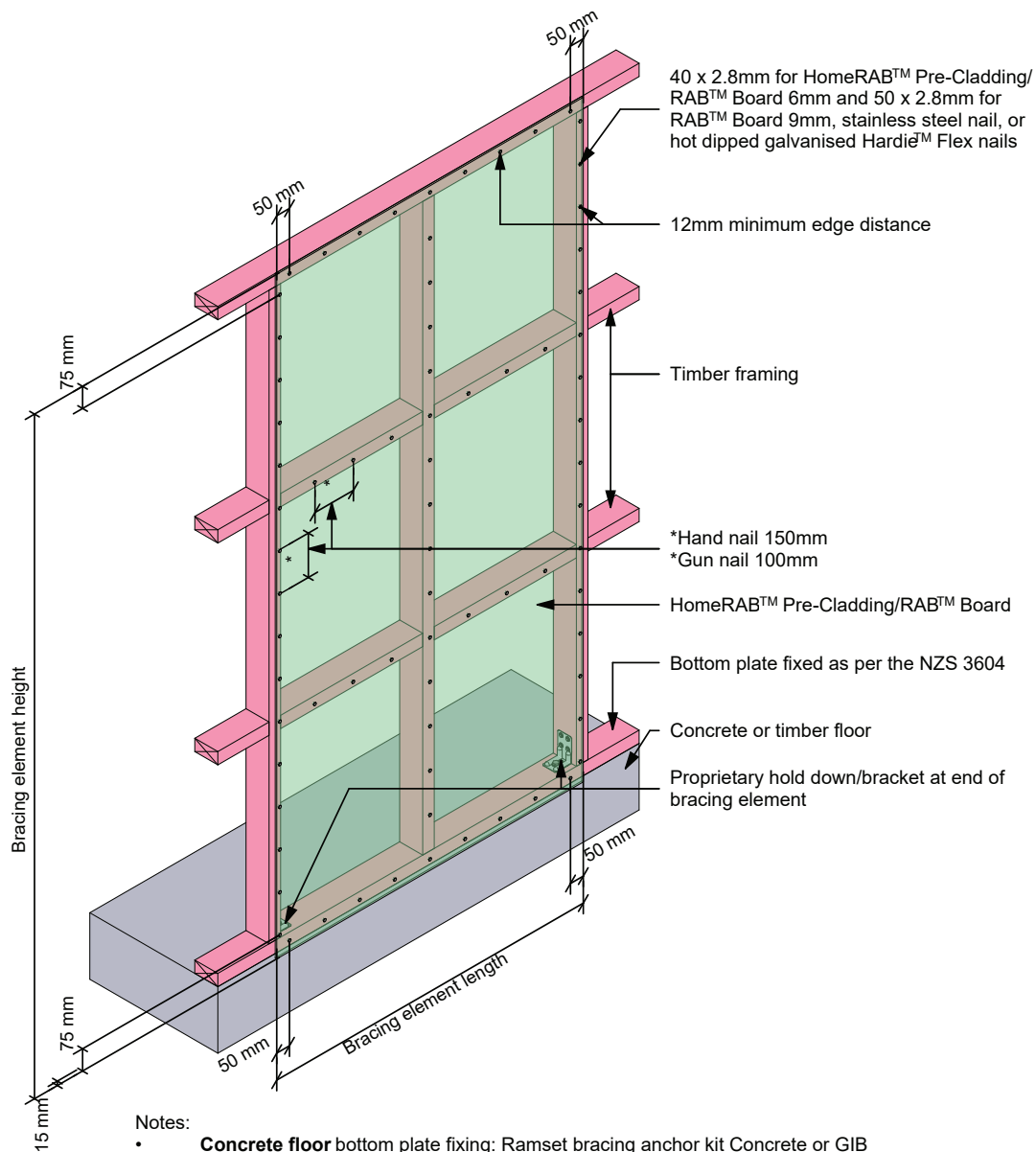
Product	System	Minimum length
HomeRAB™ Pre-Cladding	HPn	1200mm
RAB™ Board	JHDn	1200mm

Figure 29: 400/600mm HomeRAB™ Pre-Cladding or RAB™ Board to concrete or timber floor



Product	System	Minimum length
HomeRAB™ Pre-Cladding	HP	400 or 600mm
HomeRAB™ Pre-Cladding with 10mm GIB® Standard Plasterboard	HPg	400 or 600mm
RAB™ Board	JHD	400 or 600mm
RAB™ Board with 10mm GIB® Standard Plasterboard	JHDg	600mm
RAB™ Board with 10mm GIB® Braceline	JHDb	400 or 600mm
RAB™ Board with 6mm Villaboard® Lining	JHDv	400 or 600mm

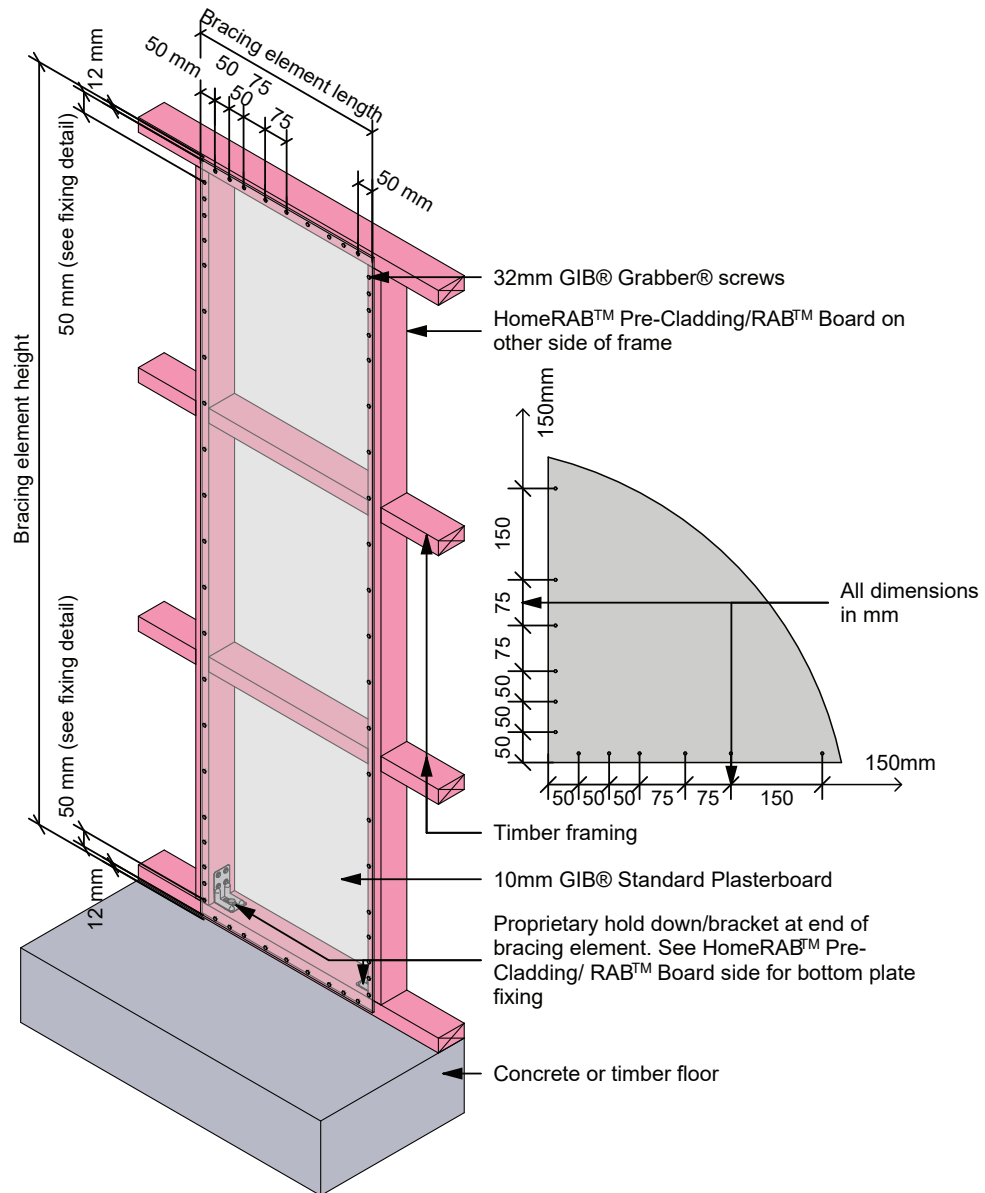
Figure 30: 1200mm HomeRAB™ Pre-Cladding or RAB™ Board to concrete or timber floor



- Notes:
- **Concrete floor** bottom plate fixing: Ramset bracing anchor kit Concrete or GIB Handibrac® with 15 kN anchor at each end of bracing element
 - **Timber floor** bottom plate fixing: Ramset bracing anchor kit Wood or GIB Handibrac® with a 12kN minimum uplift capacity screw at each end of bracing element

Product	System	Minimum length
HomeRAB™ Pre-Cladding	HP	1200mm
HomeRAB™ Pre-Cladding with 10mm GIB® Standard Plasterboard	HPg	1200mm
RAB™ Board	JHD	1200mm

Figure 31: 400mm/600mm HomeRAB™ Pre-Cladding with 10mm GIB® Standard Plasterboard

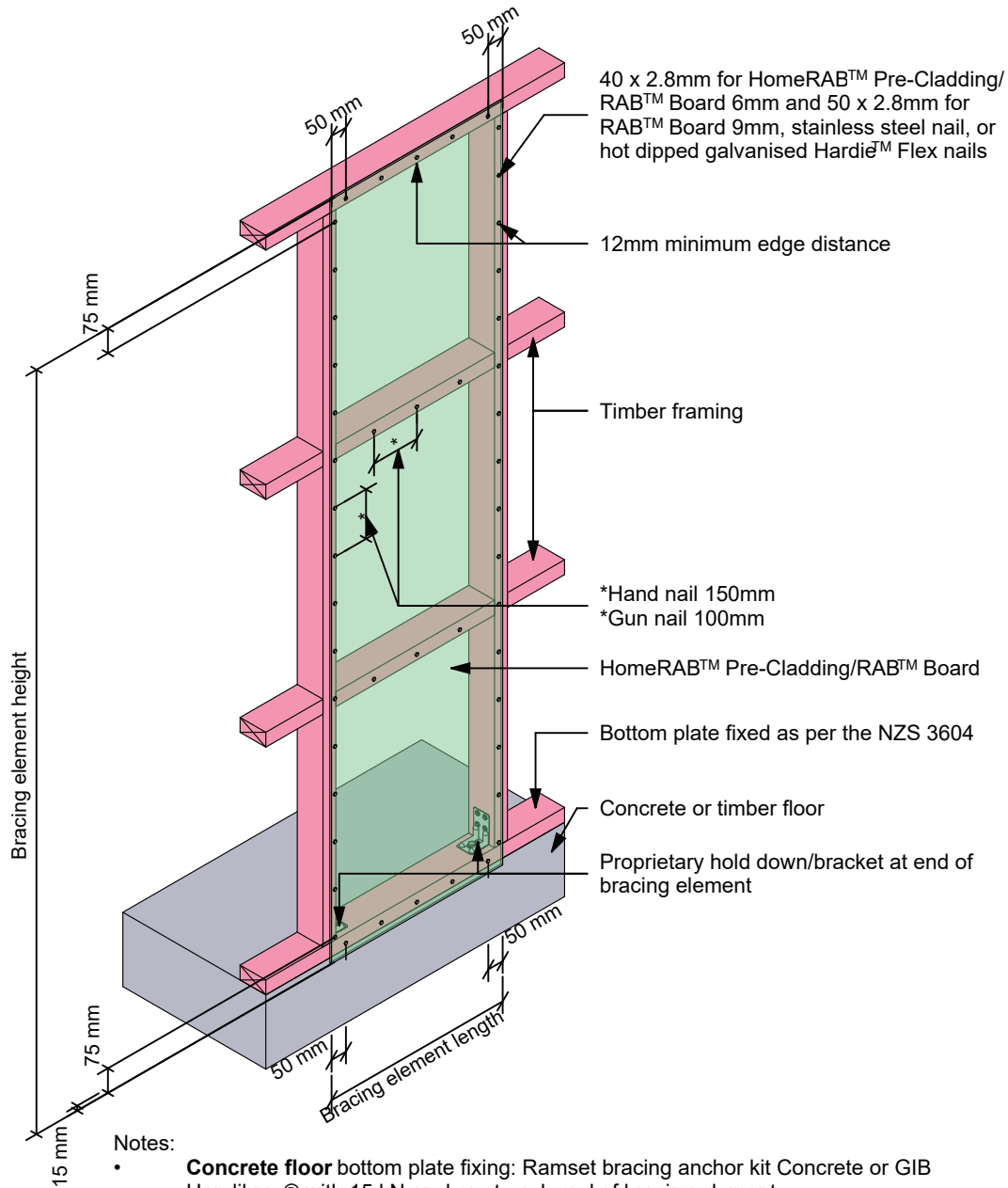


Notes:

- All GIB® Standard sheets to be fixed to Winstone Wallboards Ltd. specifications. GIB® Bracing Systems
- All GIB® bracing sheets to be stopped to Winstone Wallboards Ltd. specifications. GIB® Site Guide
- Refer to Winstone Wallboard Ltd. specification for edge distances

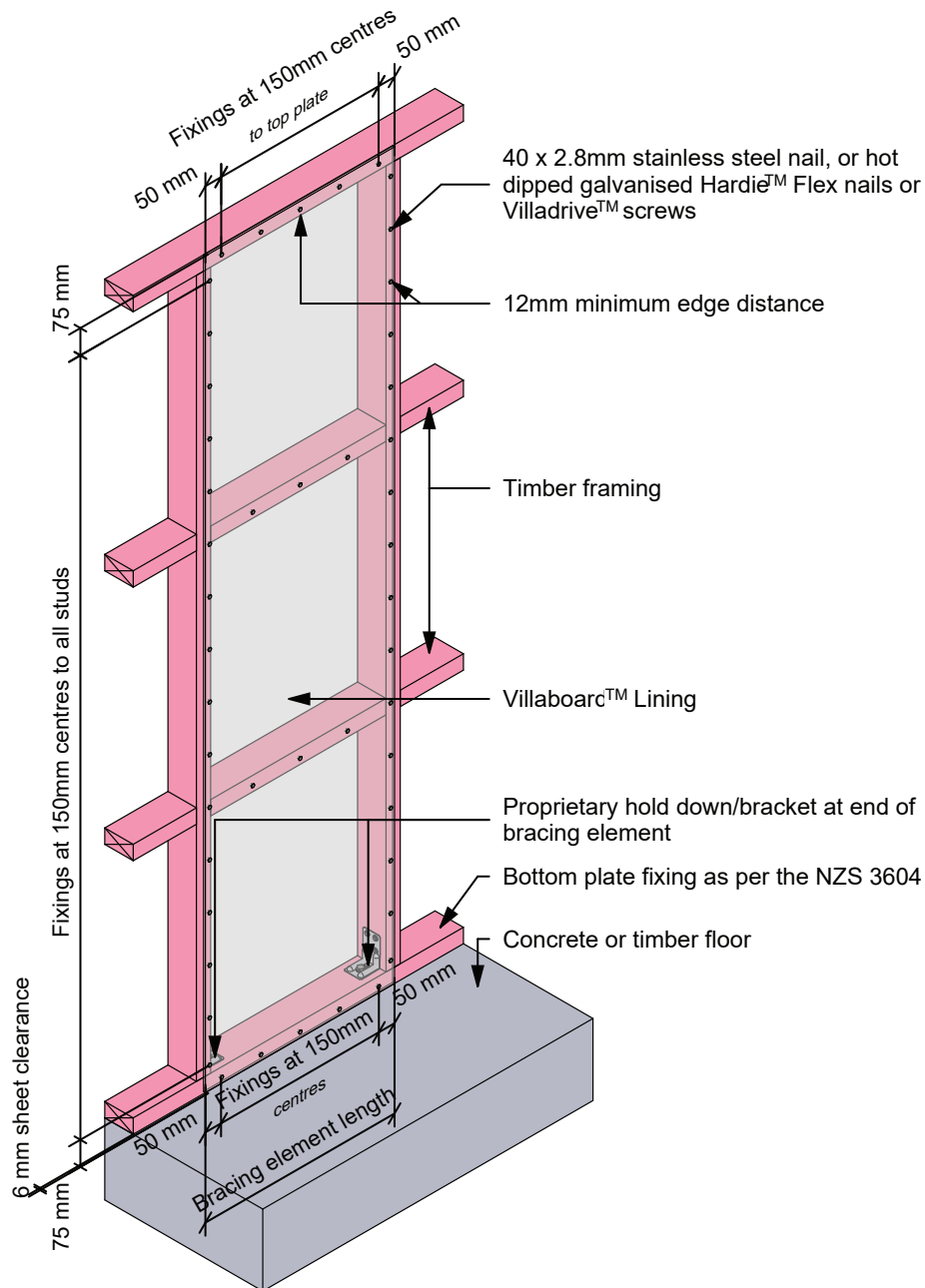
Product	System	Minimum length
HomeRAB™ Pre-Cladding	HPg	400 or 600mm
RAB™ Board	JHDg	600mm

Figure 32: 400mm/600mm RAB™ Board 6mm with 10mm GIB® Braceline



Product	System	Minimum length
RAB™ Board	JHDb	400 or 600mm

Figure 33: 400mm/600mm RAB™ Board 6mm with Villaboarc™ Lining 6mm

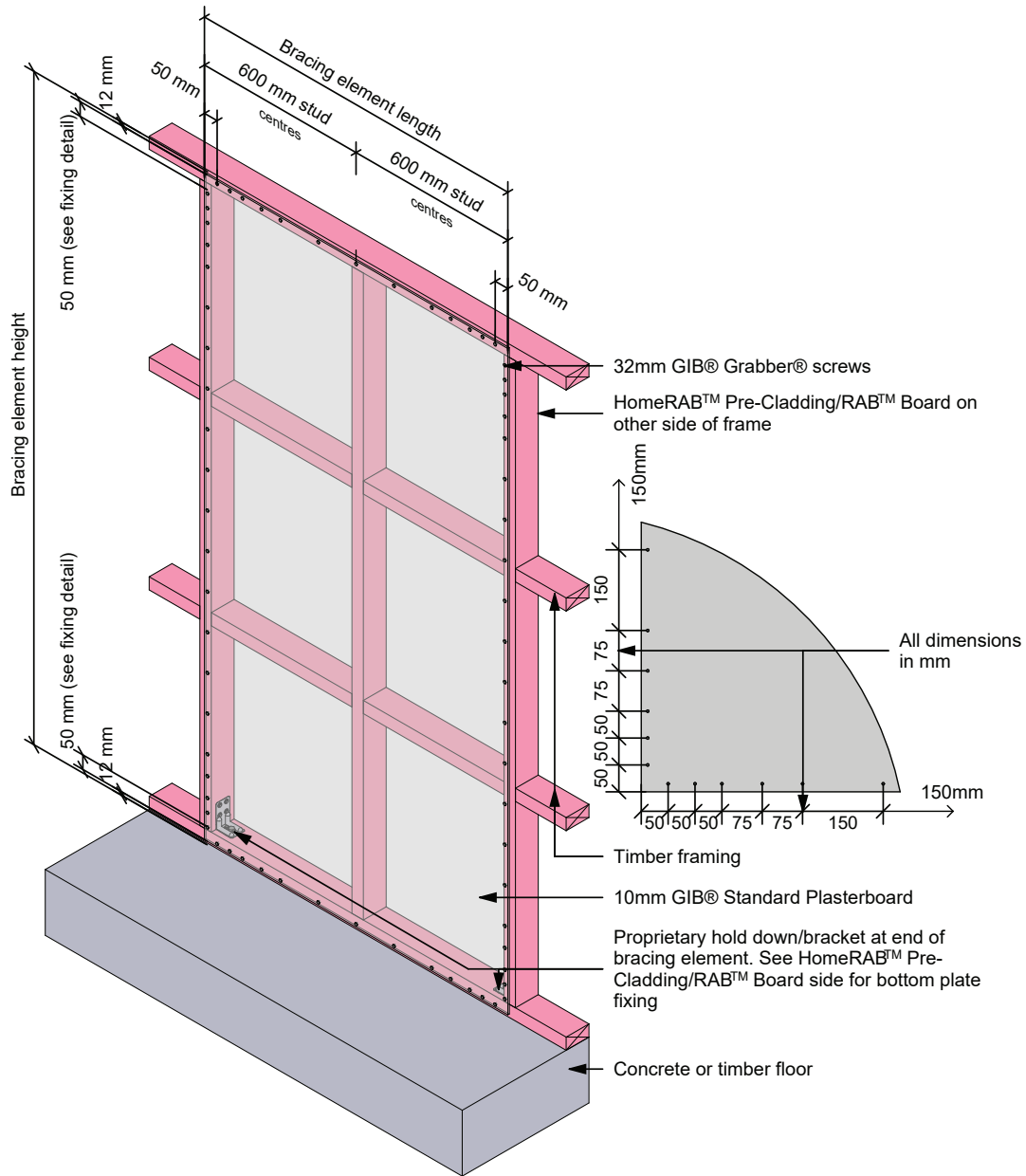


Notes:

- **Concrete floor** bottom plate fixing: Ramset bracing anchor kit Concrete or GIB Handibrac® with 15 kN anchor at each end of bracing element
- **Timber floor** bottom plate fixing: Ramset bracing anchor kit Wood or GIB Handibrac® with a 12kN minimum uplift capacity screw at each end of bracing element

Product	System	Minimum length
HomeRAB™ Pre-Cladding	HPg	400 or 600mm
RAB™ Board	JHDv	400 or 600mm

Figure 34: 1200mm HomeRAB™ Pre-Cladding with 10mm GIB® Standard Plasterboard



- Notes:
- All GIB® Standard sheets to be fixed to Winstone Wallboards Ltd. specifications. GIB® Bracing Systems
 - All GIB® bracing sheets to be stopped to Winstone Wallboards Ltd. specifications. GIB® Site Guide
 - Refer to Winstone Wallboard Ltd. specification for edge distances

Product	System	Minimum length
HomeRAB™ Pre-Cladding/GIB® Standard Plasterboard	HPg	1200mm

Bracing Construction Figures

Figure 35: Sheet layout for tall walls up to 4.2m

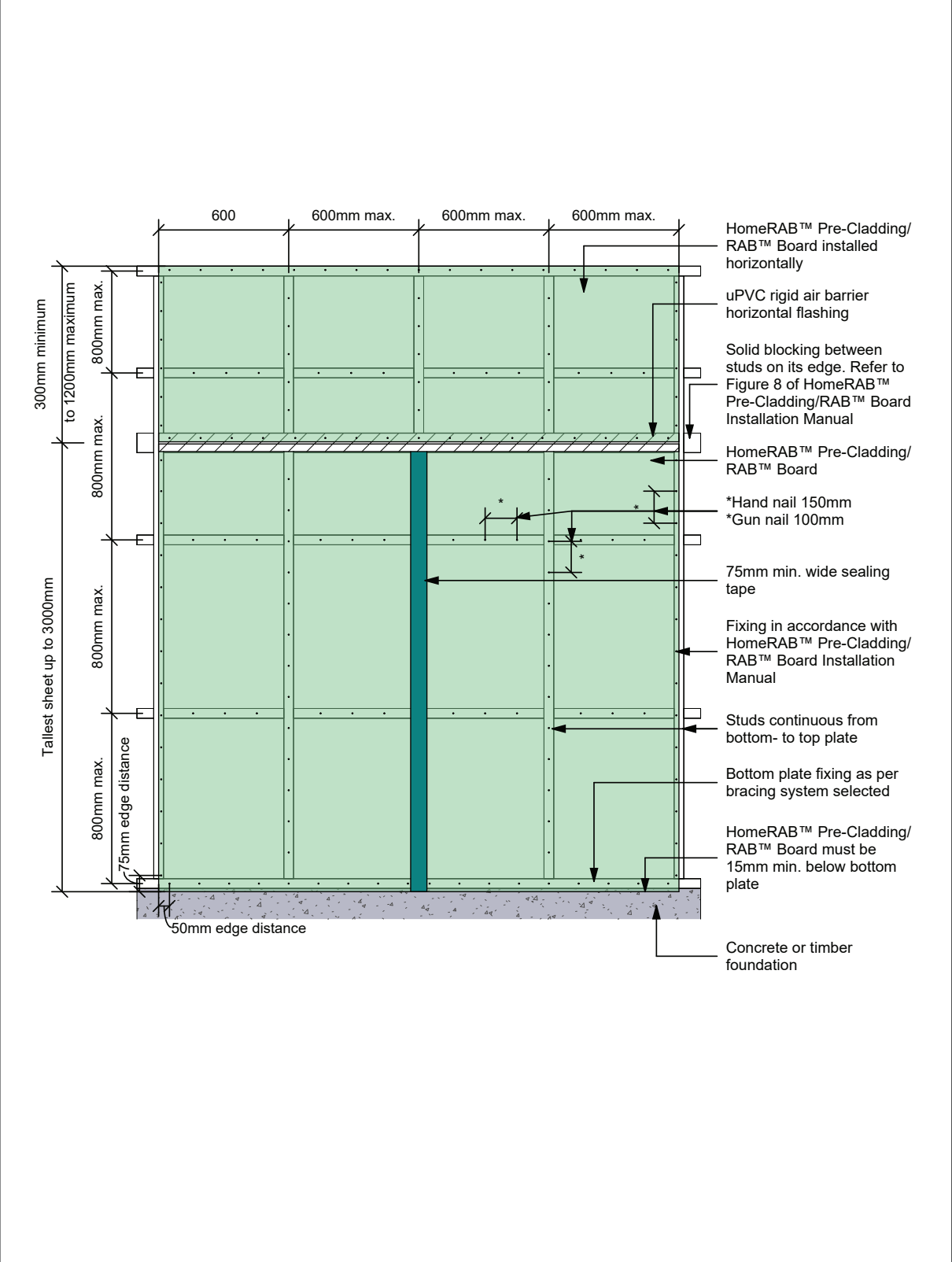


Figure 36: Sheet layout at opening

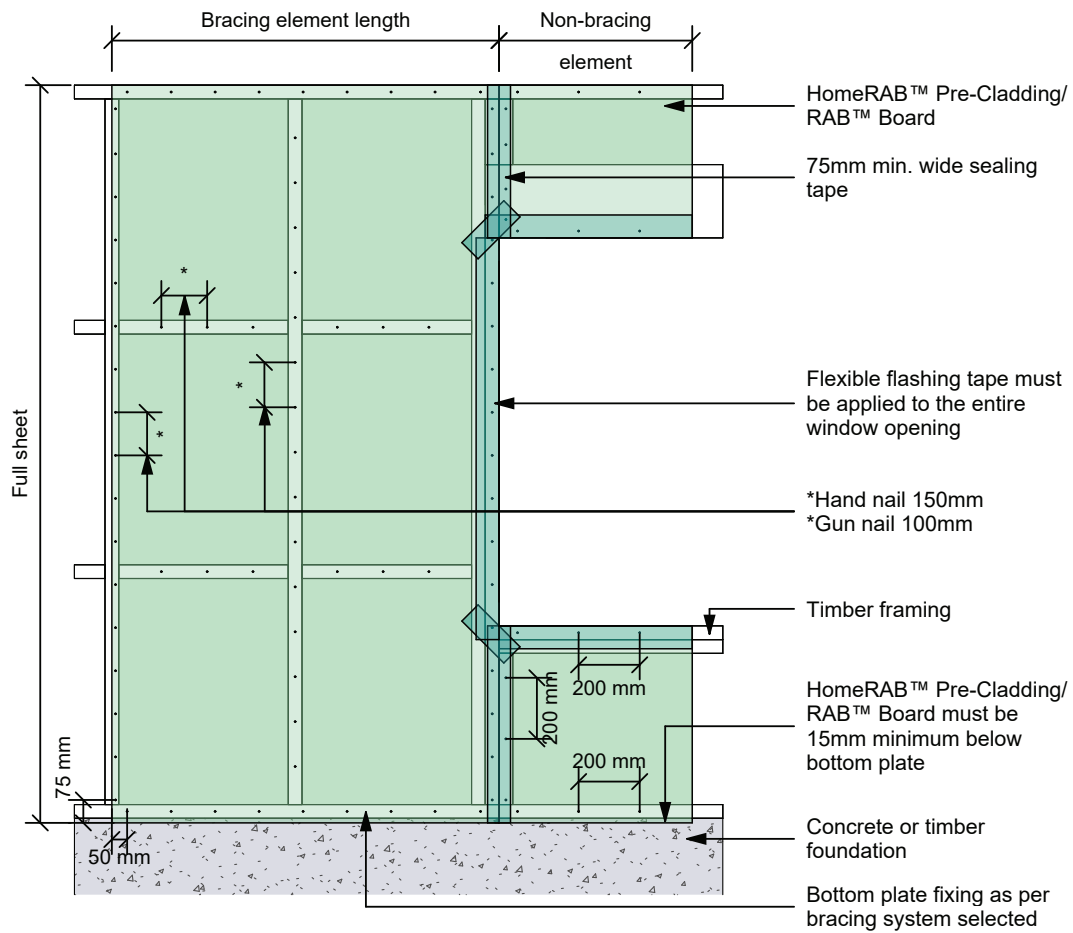
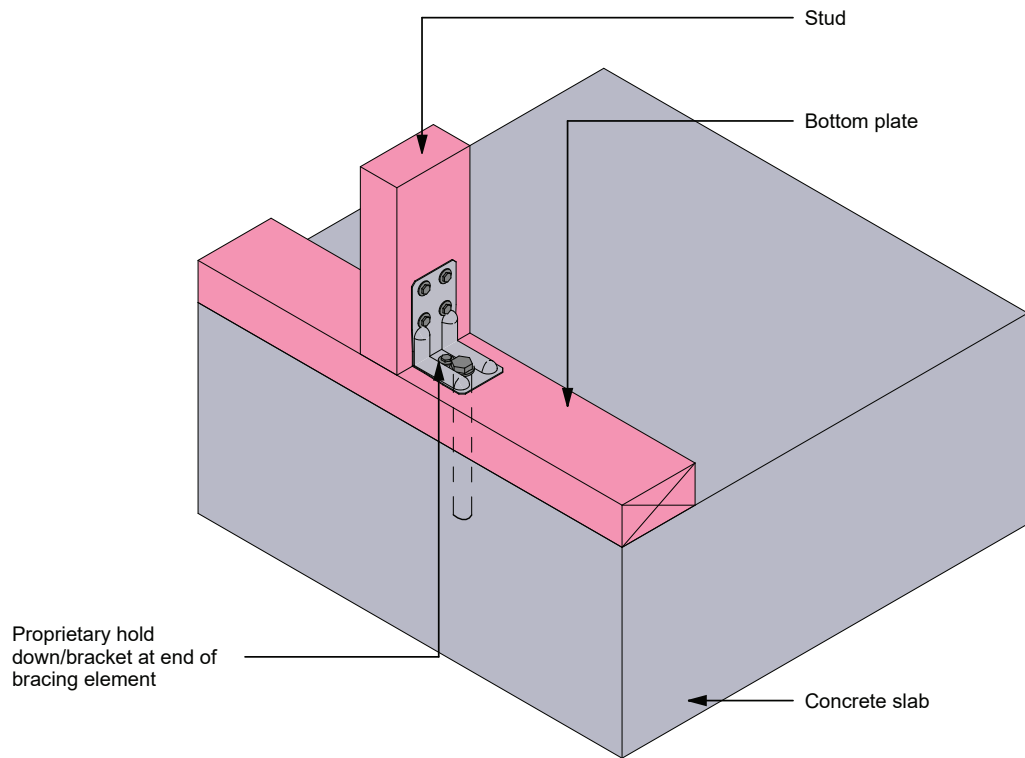


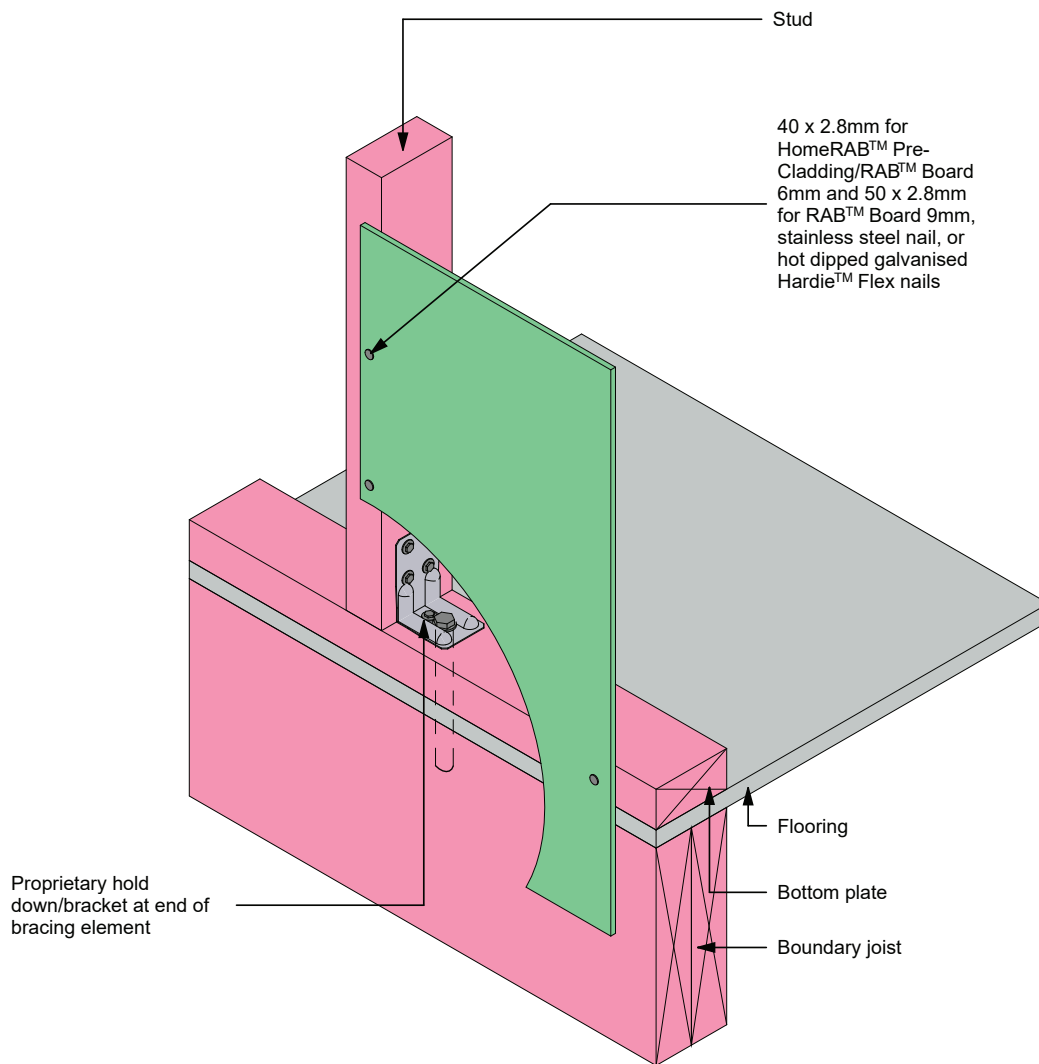
Figure 37: End bracket to concrete slab



Note:

- **Concrete floor** bottom plate fixing: Ramset bracing anchor kit Concrete or GIB Handibrac® with 15 kN anchor at each end of bracing element

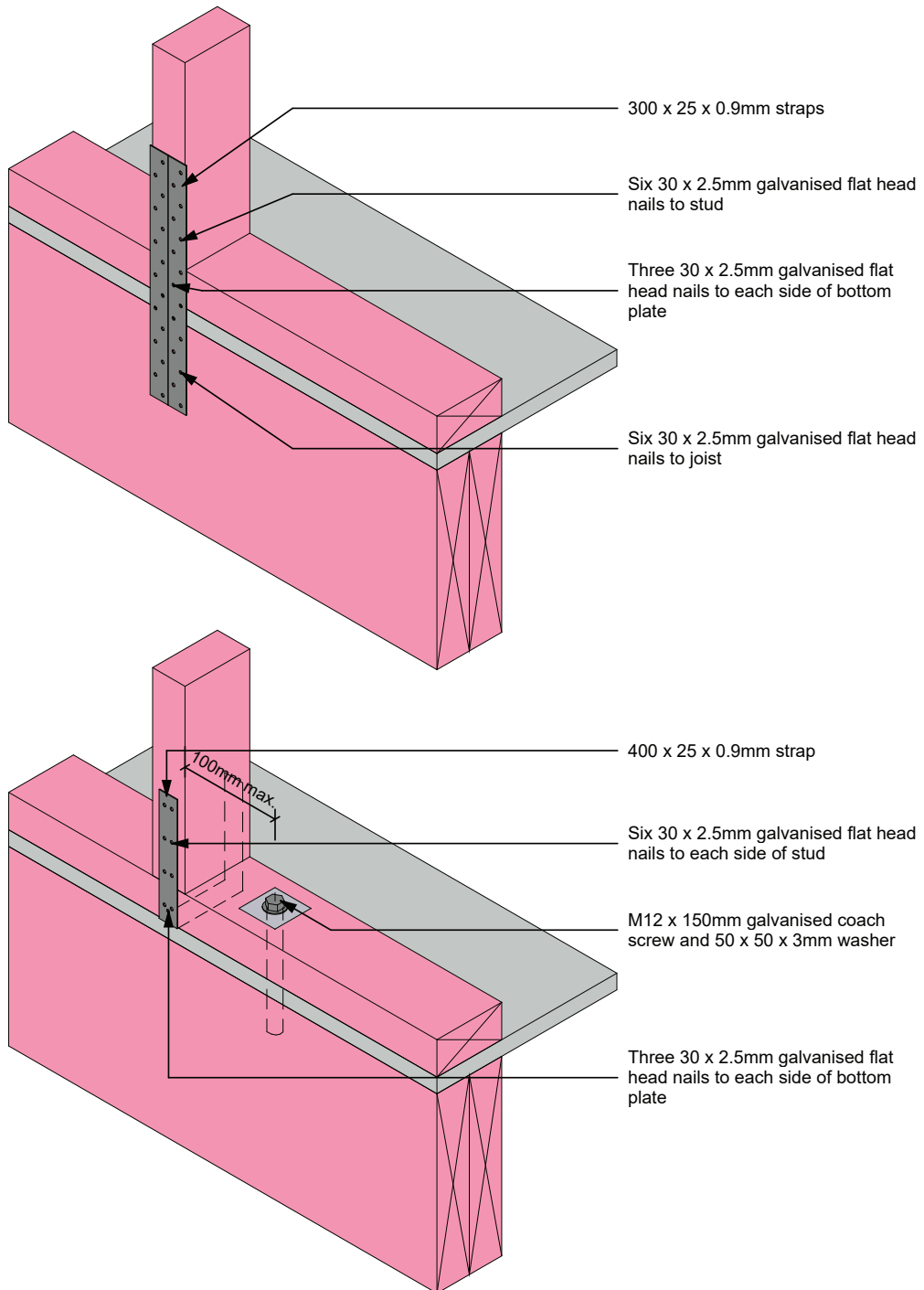
Figure 38: End bracket to timber joist



Note:

- **Timber floor** bottom plate fixing: Ramset bracing anchor kit Wood or GIB Handibrac® with a 12kN minimum uplift capacity screw at each end of bracing element

Figure 39: Hold down straps to timber joists



7 Product Information

7.1 General

HomeRAB™ Pre-Cladding and RAB™ Board are cellulose fibre reinforced cement building products. The basic composition is Portland cement, ground sand, cellulose fibre, water and proprietary additives.

RAB™ Board is easily identified by the name RAB™ Board printed on the back face. It has a green colour water repellent sealer applied on its front face.

HomeRAB™ Pre-Cladding is easily identified by the name 'HomeRAB™ Pre-Cladding' on the front face. It has a green colour water repellent sealer applied on its front face. The name is also printed on the back face of the lining.

HomeRAB™ Pre-Cladding and RAB™ Board are manufactured to conform to the requirements of the AS/NZS 2908.2 'Cellulose-Cement Products Part 2: Flat Sheet (ISO 8336).

HomeRAB™ Pre-Cladding and RAB™ Board are classified Type B, Category 3 in accordance with the AS/NZS 2908.2. For Safety Data Sheets (SDS) visit www.jameshardie.co.nz or Ask James Hardie on 0800 808 868.

7.2 Durability

Resistance to moisture/rotting

HomeRAB™ Pre-Cladding and RAB™ Board have been assessed for permanent moisture induced deterioration (rotting) and have met the performance requirements of the AS/NZS 2908.2.

Resistance to fire

HomeRAB™ Pre-Cladding and RAB™ Board have been tested/assessed and are classified as Non-Combustible Material.

7.3 Alpine Regions

In regions subject to freeze/thaw conditions, HomeRAB™ Pre-Cladding and RAB™ Board must not be in direct contact with snow or ice build up e.g. external walls in alpine regions subject to snow drifts over winter. HomeRAB™ Pre-Cladding and RAB™ Board have been tested to resist freeze thaw in accordance with the AS/NZS 2908.2 clause 8.2.3 requirements and is suitable for use in alpine regions.

8 Finishes and Maintenance

The selected cladding must be installed and finished within 180 days after the installation of HomeRAB™ Pre-Cladding and RAB™ Board, and the cladding must comply with the requirements of the NZBC. Regular cleaning and maintenance of claddings paints, joints, junctions, penetrations, flashings etc must be carried out at regular intervals and as per the requirements of the material manufacturers. Regular maintenance of cladding is also a requirement under the NZBC.

The ground clearances required for the HomeRAB™ Pre-Cladding and RAB™ Board and the cladding must always be maintained.

Product Warranty

NEW ZEALAND | Effective August 2024

This warranty is given by James Hardie New Zealand Limited (“James Hardie”, “we”, “its” and “us”).

In this warranty:

- **“Consumer”** has the meaning given to it in the Consumer Guarantees Act; ;
- **“Product”** refers to the item listed below:

HomeRAB™ Pre-Cladding

- **“Technical Literature”** means the product specific installation guide published by James Hardie at the time of installation of the product (copies of the current installation instructions are available at jameshardie.co.nz or by calling Ask James Hardie™ on 0800 808 868); and
- **“Warranty Period”** means fifteen (15) years.

Warranty

1. Subject to the conditions and limitations set out below, we warrant that for the Warranty Period from the date of purchase, the Product will be free from defects due to defective factory workmanship or materials.
2. James Hardie further warrants that for a period of 15 years from the date of purchase of the Product that any associated accessories supplied by us will be free from defects due to defective factory workmanship or materials.
3. James Hardie warrants that at the time of manufacture the Product will comply with AS/NZS 2908.2:2000 Cellulose-cement products - Flat sheet.
4. This warranty is not transferable and is only provided to and may only be relied upon by:
 - (a) the first purchaser of the Product or accessory from James Hardie; and
 - (b) the last purchaser of the Product or accessory prior to installation.
5. If a breach of this warranty occurs, we will (at our option) either: supply replacement Product or accessory; rectify the affected Product or accessory; or pay for the reasonable and substantiated cost of the replacement or rectification of the affected Product or accessory.

Warranty Conditions

6. You may only claim under this warranty if:
 - (a) the Product was installed and maintained strictly in accordance with the Technical Literature including the components or products specified or recommended in the Technical Literature; and
 - (b) other products applied to or used in conjunction with the Product are applied or installed and maintained strictly in accordance with the relevant manufacturer’s instructions and good trade practice; and
 - (c) the Product is used in an application designed and constructed in strict compliance with all relevant provisions of the New Zealand Building Code (“NZBC”), applicable laws, regulations and standards; and
 - (d) we are given reasonable opportunity to inspect the Product **before** any attempt is made to repair or remove the Product once it has been installed; and
 - (e) the requirements for bringing a claim under the warranty as set out in clause 8 are complied with.

7. Subject to clauses 10 and 11:
 - (a) to the fullest extent permitted by law, we exclude all:
 - (i) other warranties, conditions, liabilities and obligations which may otherwise apply in respect of the purchase or use of the Product and/or its Technical Literature, other than those specified in this warranty; and
 - (ii) liability for any loss or damage (whether direct or indirect) including property damage or personal injury, consequential loss, economic loss or loss of profits, the purchase or use of the Product and/or its Technical Literature whether arising in contract, tort (including negligence), statute or equity.
 - (b) if or to the extent that it is not permitted by law to so limit our liability as set out in clause 7(a), then to the fullest extent permitted by law, we limit our liability at our option to:
 - (i) the replacement of the Product or accessory or the supply of equivalent Product or accessory;
 - (ii) the repair of the Product or accessory;
 - (iii) the payment of the cost of replacing the Product or accessory, or of acquiring equivalent Product or accessory; or
 - (iv) the payment of the reasonable and substantiated cost of having the Product or accessory repaired;
 - (c) this warranty does not cover defects which are not due to defective factory workmanship or materials, including but not limited to damage or defects caused by or arising from or attributable to:
 - (i) use of the Product in applications not recommended by us or in accordance with the Technical Literature;
 - (ii) the Product being subjected to abnormal treatment including impact, abrasion or mechanical action;
 - (iii) surface marking, scratches or stains arising during or after the installation of the Product;
 - (iv) poor workmanship or installation, poor design or detailing, settlement or structural movement and/or movement of materials to which the Product is attached;
 - (v) incorrect design of the structure;
 - (vi) acts of God including but not limited to earthquakes, fire, cyclones, floods or other severe weather conditions or unusual climatic conditions;
 - (vii) efflorescence, normal wear and tear, growth of mould, mildew, fungi, bacteria, or any organism on any Product surfaces or Product (whether on the exposed or unexposed surfaces);

- (viii) contact with chemicals such as solvents, detergents and pollutants, or exposure to a harsh chemical environment or an excessively salty environment;
- (ix) use of adhesive tapes, sealants or mastics on the Product, or recoating of the surface of the Product outside of the recommended maintenance guidelines in the Technical Literature; or
- (x) failure of third party coating systems, including but not limited to sealers and paints; and
- (xi) **this warranty does not cover** any variation in the look of the Product including but not limited to: any variation in colour or surface pattern; any variation between different batches of the Product; or any variation against any sample material provided. The architect/builder/installer must ensure **prior to specification** that variation in look between items of Product is acceptable and ensure that each item of Product meets all aesthetic requirements **prior to installation**. Subject to the terms of this warranty, after installation of the Product, **we are not liable** for claims arising from aesthetic variations or defects if such variations or defects were, or would upon reasonable inspection have been, **apparent prior to installation**.

Making a Claim Under Warranty

If you are the property owner and did not purchase the product yourself, and you believe you have any issue with James Hardie product installed at your home, in the first instance you should contact the builder who purchased and installed the product. If you purchased the product yourself, you can make a claim under this warranty as detailed below.

8. In order to make a claim under this warranty, you must provide the following information in writing to us using the contact details below within 30 days after the alleged defect would have become reasonably apparent or, if the defect was reasonably apparent prior to installation, then the claim must be made prior to installation:
 - (a) proof of purchase;
 - (b) description of the defect and the issue;
 - (c) photographs of the defect; and
 - (d) your contact details.
9. Subject to New Zealand Consumer Law, you must bear any expenses you incur as a result of claiming under this warranty, except where you are entitled to recover such expenses under the New Zealand Consumer Law, in which case we will bear or otherwise reasonably compensate you for such expenses. All claims for such expenses are to be notified to us in writing within 21 days from the later of: when you make a claim under this warranty; or when we notify you that we, acting reasonably, accept responsibility for these expenses.

New Zealand Consumer Law

10. If you acquire the Product or accessories manufactured or supplied by us as a Consumer, that Product or accessories may come with guarantees that cannot be excluded under the Consumer Guarantees Act. If so, and we are a supplier, you are entitled to a replacement or refund for a failure of a substantial character or a failure that cannot be remedied, and compensation for any other reasonably foreseeable loss or damage. You are also entitled to have the goods repaired or replaced if the goods fail to be of acceptable quality or fail to meet some other guarantee and can be remedied and the failure is not of a substantial character. Where we or a related entity are the manufacturer, then you will have the rights set out in the Consumer Guarantees Act if the goods do not comply with this warranty or the consumer guarantees under the Consumer Guarantees Act.
11. Other than as lawfully excluded or limited by the other terms of this warranty, any rights a Consumer may have under this warranty are in addition to other rights and remedies of a Consumer under a law in relation to the goods to which this warranty relates. Nothing in this warranty shall exclude or modify any legal rights a purchaser and/or Consumer may have under the Consumer Guarantees Act, Fair Trading Act or otherwise which cannot be excluded or modified at law.

Disclaimer

The recommendations in James Hardie's literature are based on good building practice but are not an exhaustive statement of all relevant information. Further, as the successful performance of the relevant system depends on numerous factors outside the control of James Hardie (e.g. quality of workmanship and design) James Hardie shall not be liable for the recommendations made in that Technical Literature and the performance of the relevant system, including its suitability for any purpose or ability to satisfy the relevant provisions of the NZBC, laws, regulations and standards. It is the responsibility of the building designer to ensure that the details and recommendations provided in the relevant James Hardie Technical Literature are suitable for the intended project and that specific design is conducted where appropriate.

Our Contact Details

James Hardie New Zealand Limited

Address: 1 O'Rorke Road, Penrose, Auckland, 1061

Postal address: PO Box 12070, Penrose, Auckland 1642

Telephone: "Ask James Hardie™" on 0800 808 868

Website: www.jameshardie.co.nz

Email: info@jameshardie.co.nz

Product Warranty

NEW ZEALAND | Effective August 2024

This warranty is given by James Hardie New Zealand Limited (“James Hardie”, “we”, “its” and “us”).

In this warranty:

- **“Consumer”** has the meaning given to it in the Consumer Guarantees Act; ;
- **“Product”** refers to the item listed below:

RAB™ Board

- **“Technical Literature”** means the product specific installation guide published by James Hardie at the time of installation of the product (copies of the current installation instructions are available at jameshardie.co.nz or by calling Ask James Hardie™ on 0800 808 868); and
- **“Warranty Period”** means fifteen (15) years.

Warranty

1. Subject to the conditions and limitations set out below, we warrant that for the Warranty Period from the date of purchase, the Product will be free from defects due to defective factory workmanship or materials.
2. James Hardie further warrants that for a period of 15 years from the date of purchase of the Product that any associated accessories supplied by us will be free from defects due to defective factory workmanship or materials.
3. James Hardie warrants that at the time of manufacture the Product will comply with AS/NZS 2908.2:2000 Cellulose-cement products - Flat sheet.
4. This warranty is not transferable and is only provided to and may only be relied upon by:
 - (a) the first purchaser of the Product or accessory from James Hardie; and
 - (b) the last purchaser of the Product or accessory prior to installation.
5. If a breach of this warranty occurs, we will (at our option) either: supply replacement Product or accessory; rectify the affected Product or accessory; or pay for the reasonable and substantiated cost of the replacement or rectification of the affected Product or accessory.

Warranty Conditions

6. You may only claim under this warranty if:
 - (a) the Product was installed and maintained strictly in accordance with the Technical Literature including the components or products specified or recommended in the Technical Literature; and
 - (b) other products applied to or used in conjunction with the Product are applied or installed and maintained strictly in accordance with the relevant manufacturer’s instructions and good trade practice; and
 - (c) the Product is used in an application designed and constructed in strict compliance with all relevant provisions of the New Zealand Building Code (“NZBC”), applicable laws, regulations and standards; and
 - (d) we are given reasonable opportunity to inspect the Product **before** any attempt is made to repair or remove the Product once it has been installed; and
 - (e) the requirements for bringing a claim under the warranty as set out in clause 8 are complied with.

7. Subject to clauses 10 and 11:
 - (a) to the fullest extent permitted by law, we exclude all:
 - (i) other warranties, conditions, liabilities and obligations which may otherwise apply in respect of the purchase or use of the Product and/or its Technical Literature, other than those specified in this warranty; and
 - (ii) liability for any loss or damage (whether direct or indirect) including property damage or personal injury, consequential loss, economic loss or loss of profits, the purchase or use of the Product and/or its Technical Literature whether arising in contract, tort (including negligence), statute or equity.
 - (b) if or to the extent that it is not permitted by law to so limit our liability as set out in clause 7(a), then to the fullest extent permitted by law, we limit our liability at our option to:
 - (i) the replacement of the Product or accessory or the supply of equivalent Product or accessory;
 - (ii) the repair of the Product or accessory;
 - (iii) the payment of the cost of replacing the Product or accessory, or of acquiring equivalent Product or accessory; or
 - (iv) the payment of the reasonable and substantiated cost of having the Product or accessory repaired;
 - (c) this warranty does not cover defects which are not due to defective factory workmanship or materials, including but not limited to damage or defects caused by or arising from or attributable to:
 - (i) use of the Product in applications not recommended by us or in accordance with the Technical Literature;
 - (ii) the Product being subjected to abnormal treatment including impact, abrasion or mechanical action;
 - (iii) surface marking, scratches or stains arising during or after the installation of the Product;
 - (iv) poor workmanship or installation, poor design or detailing, settlement or structural movement and/or movement of materials to which the Product is attached;
 - (v) incorrect design of the structure;
 - (vi) acts of God including but not limited to earthquakes, fire, cyclones, floods or other severe weather conditions or unusual climatic conditions;
 - (vii) efflorescence, normal wear and tear, growth of mould, mildew, fungi, bacteria, or any organism on any Product surfaces or Product (whether on the exposed or unexposed surfaces);

- (viii) contact with chemicals such as solvents, detergents and pollutants, or exposure to a harsh chemical environment or an excessively salty environment;
- (ix) use of adhesive tapes, sealants or mastics on the Product, or recoating of the surface of the Product outside of the recommended maintenance guidelines in the Technical Literature; or
- (x) failure of third party coating systems, including but not limited to sealers and paints; and
- (xi) **this warranty does not cover** any variation in the look of the Product including but not limited to: any variation in colour or surface pattern; any variation between different batches of the Product; or any variation against any sample material provided. The architect/builder/installer must ensure **prior to specification** that variation in look between items of Product is acceptable and ensure that each item of Product meets all aesthetic requirements **prior to installation**. Subject to the terms of this warranty, after installation of the Product, **we are not liable** for claims arising from aesthetic variations or defects if such variations or defects were, or would upon reasonable inspection have been, **apparent prior to installation**.

Making a Claim Under Warranty

If you are the property owner and did not purchase the product yourself, and you believe you have any issue with James Hardie product installed at your home, in the first instance you should contact the builder who purchased and installed the product. If you purchased the product yourself, you can make a claim under this warranty as detailed below.

8. In order to make a claim under this warranty, you must provide the following information in writing to us using the contact details below within 30 days after the alleged defect would have become reasonably apparent or, if the defect was reasonably apparent prior to installation, then the claim must be made prior to installation:
 - (a) proof of purchase;
 - (b) description of the defect and the issue;
 - (c) photographs of the defect; and
 - (d) your contact details.
9. Subject to New Zealand Consumer Law, you must bear any expenses you incur as a result of claiming under this warranty, except where you are entitled to recover such expenses under the New Zealand Consumer Law, in which case we will bear or otherwise reasonably compensate you for such expenses. All claims for such expenses are to be notified to us in writing within 21 days from the later of: when you make a claim under this warranty; or when we notify you that we, acting reasonably, accept responsibility for these expenses.

New Zealand Consumer Law

10. If you acquire the Product or accessories manufactured or supplied by us as a Consumer, that Product or accessories may come with guarantees that cannot be excluded under the Consumer Guarantees Act. If so, and we are a supplier, you are entitled to a replacement or refund for a failure of a substantial character or a failure that cannot be remedied, and compensation for any other reasonably foreseeable loss or damage. You are also entitled to have the goods repaired or replaced if the goods fail to be of acceptable quality or fail to meet some other guarantee and can be remedied and the failure is not of a substantial character. Where we or a related entity are the manufacturer, then you will have the rights set out in the Consumer Guarantees Act if the goods do not comply with this warranty or the consumer guarantees under the Consumer Guarantees Act.
11. Other than as lawfully excluded or limited by the other terms of this warranty, any rights a Consumer may have under this warranty are in addition to other rights and remedies of a Consumer under a law in relation to the goods to which this warranty relates. Nothing in this warranty shall exclude or modify any legal rights a purchaser and/or Consumer may have under the Consumer Guarantees Act, Fair Trading Act or otherwise which cannot be excluded or modified at law.

Disclaimer

The recommendations in James Hardie's literature are based on good building practice but are not an exhaustive statement of all relevant information. Further, as the successful performance of the relevant system depends on numerous factors outside the control of James Hardie (e.g. quality of workmanship and design) James Hardie shall not be liable for the recommendations made in that Technical Literature and the performance of the relevant system, including its suitability for any purpose or ability to satisfy the relevant provisions of the NZBC, laws, regulations and standards. It is the responsibility of the building designer to ensure that the details and recommendations provided in the relevant James Hardie Technical Literature are suitable for the intended project and that specific design is conducted where appropriate.

Our Contact Details

James Hardie New Zealand Limited

Address: 1 O'Rorke Road, Penrose, Auckland, 1061

Postal address: PO Box 12070, Penrose, Auckland 1642

Telephone: "Ask James Hardie™" on 0800 808 868

Website: www.jameshardie.co.nz

Email: info@jameshardie.co.nz

