

Model: LR

The Holyoake Series LR Fire / Combination Fire and Smoke Dampers are designed to impede the spread of fire and smoke between building compartments, whilst maintaining the barriers integrity. The low leakage damper blade assembly with blade tip sealing ring, forms a solid barrier against flame, smoke and hot gases.

Complying with AS/NZS 1682 - 2015 the LR Fire Damper is certified for a **4 hour rating in a masonry concrete wall / floor** and a **2 hour rating in a plasterboard wall**.

Available in five different diameters, 100, 125, 150, 200, 250.

Note: Size 100 utilises LR 125 damper with 100-125 adaptor collars.

Configurations

- LR Fire damper with brass fusible link
- LR Combination Fire and Smoke damper with spring return actuator and electro-thermal link

Fire / Smoke Rating:

Tested in accordance with Standards AS 1530.4 – 2014 and AS1530.7-2007, integrity was maintained for in excess of 4 hours and smoke leakage below 50l/s.

For the purposes of the Australian and New Zealand Building Code they have a F.R.L./F.R.R. of -/240/-.

• CSIRO

Fire Test Certificate in accordance with AS1530.4-2014

LR Fire/Smoke Damper mounted in a 150mm thick masonry / concrete wall / floor.

[Certified for 240 minute fire rating].

• CSIRO

Fire Test Certificate in accordance with AS1530.4-2014

LR Fire/Smoke Damper mounted in a 128mm thick plasterboard wall.

[Certified for 120 minute fire rating].

• Exova Warringtonfire

Smoke leakage test certificate No. SFC 2358000.5 in accordance with AS1530.7-2007

Leakage below 50l/s @ 200C in accordance with AS1682.1-2015

The LR Damper integrates both a fire, smoke and control damper into one easy to install, maintain and test unit. It is supplied complete with mounting flanges. The patented heat shield can also be supplied for plasterboard walls.

Fire protection is provided by a fusible link (manual or electro-thermal) and damper blade that seals the duct shut in the event of a fire and maintains minimum leakage as required by the test standard.

Features

- Simple installation with flat head screwdriver utilising patented clamping system
 - No sealant
 - No fixings required
- Minimal onsite labour
- Smoke leakage rated to AS1530.7-2007
- Option actuator and attachment *required for smoke damper function
- Available sizes 100, 125, 150, 200 and 250mm
- Easy test and reset fusible link
- Adjustable blade for airflow balancing

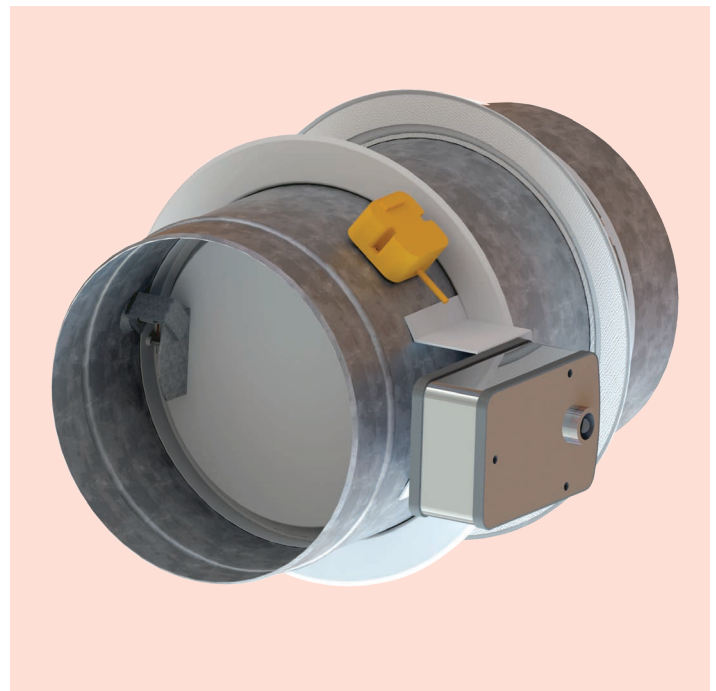

Dimensions:

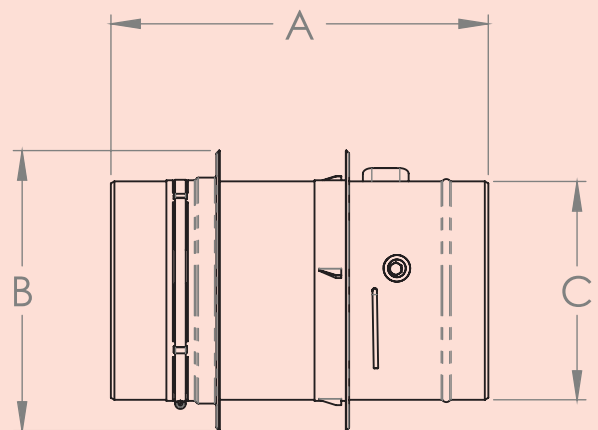

	LR 100/125	LR 150	LR 200	LR 250
A	425	425	425	425
B	190	215	265	315
C	96/121	146	196	246

Note: All Dimensions in mm.

LR – Installation Performance Data

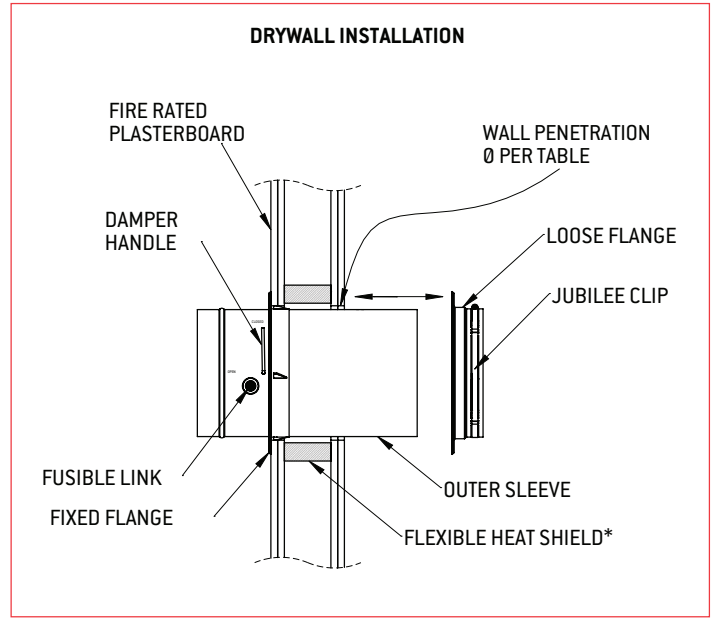
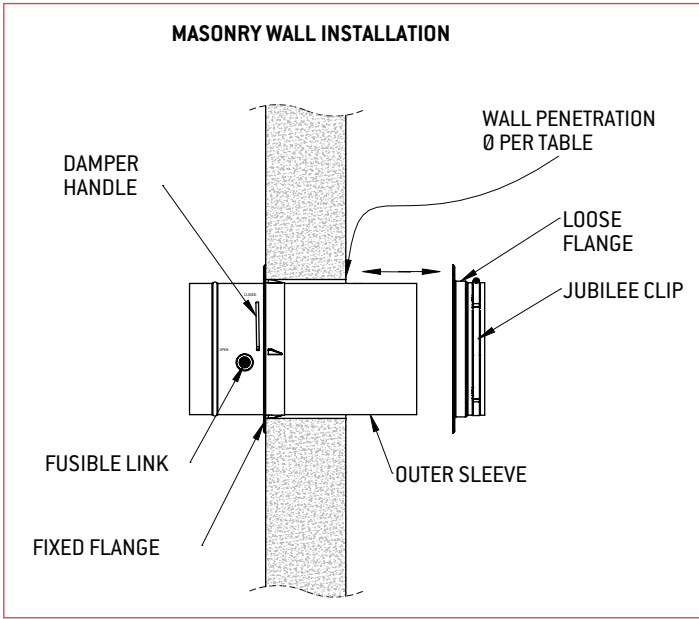

Installation Instructions

1. Remove loose flange from damper
2. Insert damper into penetration until fixed flange is firmly seated on fire barrier.
3. Slide loose flange onto damper and tighten jubilee clip with screwdriver.
4. Using damper handle and fusible link test damper operation and then set blade to required position.

* For plasterboard installation only: insert Holyoake flexible heat shield ring into penetration.

Penetration Sizing (mm)	
LR100/125	130-138
LR 150	155-163
LR 200	205-213
LR 250	255-263

LR Fire and Smoke Damper Pressure Drop				
Flow Rate (l/s)	125	150	200	250
20	4.8	1.1	1.6	1.6
40	15.0	4.6	2.2	1.9
60	30.6	10.8	3.3	2.4
80	53.7	19.6	4.6	3.2
100	83.2	31.8	6.7	4.3
120	116.1	44.3	8.8	5.5
140	152.1	57.9	11.6	6.8
160		73.3	14.8	8.3
180		92.3	18.4	10.1
200		112.7	23.1	12.3
240			32.4	16.9
280			43.1	22.3
320			54.1	29.3
360				36.6
400				44.3
440				52.0
480				63.3
520				73.3

Guide Product Weights	
LR Model	Approximate Weight in Kg
LR100	1.6
LR125	1.4
LR150	1.65
LR200	2.25
LR250	2.8
LR Heatshield	0.35

Product Ordering Key and Suggested Specifications

LR	100	FS	0
.....	125	H
Model	150	Fire Smoke (with	0 - without
	200	actuator)	heatsheid
	250		H - with heatsheid
		
	Size		

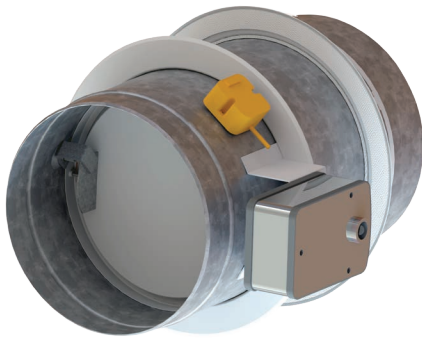

Holyoake LR Fire and Smoke Dampers shall have a 4 hour rating in a masonry wall and a 2 hour rating in a steel, or timber framed wall.

The rating shall be certified to AS 1530.4-2014, 1530.7-2007 and to the requirements of AS 1682.1/2-2015. The rating applies to fires on both sides of a fire wall. Holyoake LR Fire and Smoke Dampers contain an electro-thermal link that releases and allows the damper to close upon reaching 72°C. An actuator is included as standard that can be signalled to close by a building management system.

LR Fire and Smoke Dampers should be annually tested as determined by AS 1851 - 2012 (Section 13). Routine service of fire protection systems and equipment.

LR Fire & Smoke Dampers shall be Holyoake Series LR FS and shall be manufactured and supplied by Holyoake.

LR	100	F	0
.....	125	H
Model	150	Fire (manual)	0 - without
	200		heatsheid
	250		H - with heatsheid
		
	Size		

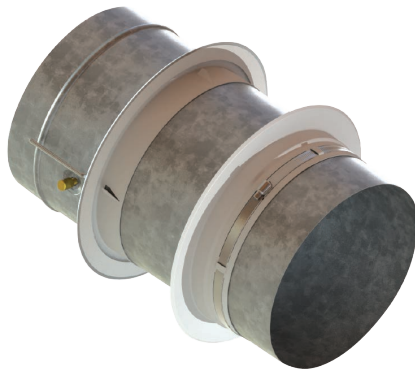

Holyoake LR Fire Dampers shall have a 4 hour rating in a masonry wall and a 2 hour rating in a steel, or timber framed wall.

The rating shall be certified to AS 1530.4-2014 and to the requirements of AS 1682.1/2-2015. The rating applies to fires on both sides of a fire wall. Holyoake LR Fire Dampers contain a fusible link that releases and allows the damper to close upon reaching 71°C. An external lockable handle is included as standard that can be used to position the damper blade to provide volume control.

LR Fire Dampers should be annually tested as determined by AS 1851 - 2012 (Section 13). Routine service of fire protection systems and equipment.

LR Fire Dampers shall be Holyoake Series LR F and shall be manufactured and supplied by Holyoake.

Patent Pending