



# AMBIHEAT™ SIDE VENT HEAT PUMP

RHEEM LEADING INNOVATIVE  
HEAT PUMP TECHNOLOGY



STEADY, HOT & STRONG

INSTALL A RHEEM®



# RHEEM HEAT PUMP

Rheem Heat Pump water heaters are an energy efficient, affordable way to heat water. Heat Pumps use the heat from the surrounding air to heat your water and help reduce your water heating energy consumption compared to an electric water heater. They work all year round, day or night, in sunshine or rain and even on cooler days, as there is always heat in the atmosphere which can be used.

## FEATURES

- No need for solar collectors - perfect where roof space is limited
- Can use the same connections as an electric water heater
- Ideal upgrade from a standard electric water heater
- Vitreous Enamel lined tank
- Saves energy compared to an electric water heater
- Includes a back-up element, delivering hot water, for the coldest winter nights



**WORKS DAY & NIGHT**  
Heat Pumps draw heat from the surrounding air to heat the water



**BACK-UP ELEMENT**  
Provides hot water even in very cold conditions



**COP OF 4.5**  
Coefficient of Performance (COP)\* of 4.5 making Model A55127005 a highly efficient water heater to help reduce energy consumption



**FROST PROTECTED**  
Suitable for cold and frost climates

**1 kW POWER INPUT**

**4.5 kW FOR WATER HEATING**

**CONTINUOUS RENEWABLE HOT WATER NO MATTER IF CLOUDY, RAIN OR SHINE**

**Heat Pump increases energy efficiency by extracting heat from the surrounding air**

**Heat Pump absorbs the heat from the surrounding air into the refrigeration system and is drawn across the evaporator.**

**The microchannel heat exchanger transfers the heat from the refrigeration process.**

**The water reaches the set temperature through this continuous process.**

\*Note: Artistic impression of micro-channels. Actual design varies.



RENEWABLE HOT WATER 365 DAYS A YEAR  
RHEEM AMBIHEAT™ SIDEVENT HEAT PUMP

# RHEEM AMBIHEAT™ HDC-270 270L HEAT PUMP

The AMBIHEAT™ HDC-270 Heat Pump is a smart, energy efficient alternative for areas where a traditional solar water heater may not be suitable. It uses the heat from the surrounding air, to heat your water and provides a reliable, efficient and sustainable way to reduce your water heating energy consumption. A Heat Pump works day and night as it extracts heat from the surrounding air and doesn't rely on direct sunlight to operate.

- Advanced wrap around microchannel heating technology for uniform and faster water heating
- Suitable for cold climates with an operating range from -5°C to 43°C<sup>5</sup>
- Suitable for harsh water conditions<sup>2</sup>
- Save up to 66% on your water heating energy consumption compared to an electric water heater<sup>3</sup>
- High recovery rate for fast heating and 2.4kW back-up element
- User-friendly touch screen LED display
- 7 year cylinder warranty<sup>4</sup>
- Suitable for households with 2–5 people

MODEL	A55127005
Tank capacity (litres)	270
Type of tank	Vitreous Enamel lined
Suitable for climate <sup>5</sup>	Tropical, Temperate and Cold climates
Frost protected	✓
Suitable for harsh water <sup>2</sup>	✓



Model: A55127005



### ULTRANAMEL™ COATING

Reduce the risk of corrosion



### SMART LED CONTROLLER DISPLAY

A bright interactive LED touchscreen display putting control at your fingertips



### MICROCHANNEL TECHNOLOGY

Provide a larger contact area for faster heating



### DURABLE TOP COVER

With its durable ABS and ASA\* top cover, the unit can easily withstand all weather conditions



### SIDE FAN DESIGN

Design specially developed to protect the unit from heavy rain

\*Acrylonitrile Butadiene Styrene (ABS) is an opaque thermoplastic and amorphous polymer and Acrylonitrile Styrene Acrylate (ASA), also called Acrylic Styrene Acrylonitrile, is an amorphous thermoplastic with improved weather resistance

# PRODUCT INFORMATION

MODEL	UNIT	HDc-270
System		A55127005
Storage capacity	litres	270
Boost capacity	litres	195
Rated heat pump power input	watts	985
Element rating	kW	2.4
Coefficient of Performance (COP) <sup>1</sup>		4.5
Noise Level @ 1 metre <sup>6</sup>	dB(A)	47
People per household		2 to 5
Dimensions & Specifications		
Heater height (A)	mm	1825
Heater width (B)	mm	690
Heater depth (C)	mm	720
Heater weight - Empty	kg	135
Heater weight - Full	kg	305
Refrigerant		R134a
Water Connections & Settings		
Inlet		RP 3/4
Outlet		RP 3/4
Temp press relief valve setting	kPa	1000
Expansion control valve	kPa	850
Maximum Mains Supply Pressure		
With expansion control valve	kPa	680
Without expansion control valve	kPa	800

HEAT PUMP PERFORMANCE SPECIFICATIONS				
Ambient air temperature	Relative humidity	Recovery rate @45°C rise (L/hr)	Average heating capacity (kW)	Coefficient of Performance (COP)
7°C	87%	54	2.8	3.6
19°C	66%	77	3.9	4.5
32°C	38%	90	4.7	4.8

BACK-UP ELEMENT RECOVERY RATE @ 240V TEMPERATURE RISE OF				
Rating (kW)	Current (Amps)	30°C (L/hr)	40°C (L/hr)	50°C (L/hr)
2.4	15	69	52	41



INSTALL A RHEEM™

Rheem New Zealand Limited

Freephone 0800 657 336

Freefax 0800 657 337

Telephone 09 829 0200

475 Rosebank Road, Avondale 1026

PO Box 19011, Avondale,

Auckland 1746, New Zealand

www.rheem.co.nz

350mm minimum distance from air inlet to wall or obstruction measured horizontally along wall. 900mm minimum recommended for service.

1000mm minimum distance from air outlet to wall or obstruction measured horizontally along wall. 900mm minimum recommended for service.

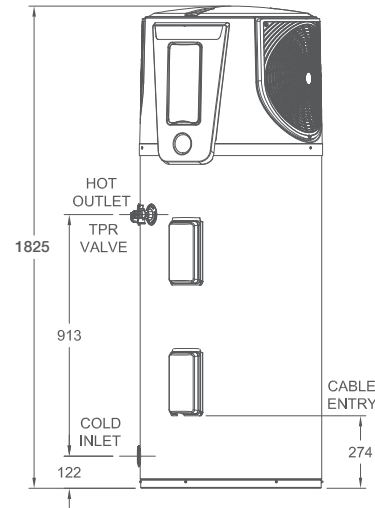
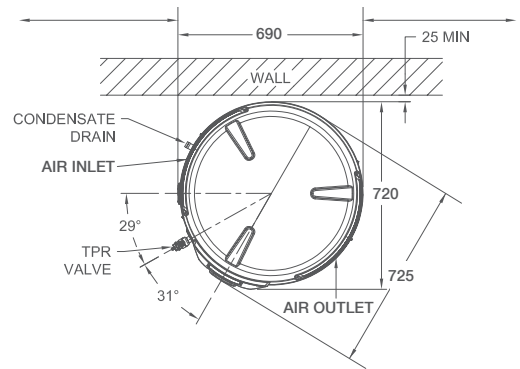

<sup>1</sup>COP – The Coefficient of Performance for a Heat Pump is the ratio of how much useful heat it produces for water heating to the power input into the water heater. The higher the COP number, the more efficient the Heat Pump is.

**Ambient Air Temperature & Humidity** – The performance of a Heat Pump changes with ambient air temperature, humidity and incoming water temperature. The warmer the air temperature, the higher the Relative Humidity and the cooler the water temperature, the higher is the heating rate of the Heat Pump. Performance specifications stated in relation to the Heat Pump are measured at predefined conditions during its testing.

**Average Heating Capacity (kW)** – This is how much heating power is put into the water during the heating cycle. It is expressed as an average due to the changes in heating power from the refrigeration cycle as the water is being heated and its temperature increases during the heating cycle.

**Recovery Rate @ 45°C rise (L/hr)** – Is the number of litres of water that can be heated through a 45°C temperature rise in one hour, e.g. when the air temperature is 19°C, the Heat Pump can heat 77 litres of 15°C to 60°C in one hour.



A Greater Degree of Good™ represents our global commitment to sustainability.

- Testing at ambient temperature: 19°C/15°C (Dry Bulb/Wet Bulb) and ambient temperature from 15°C to 55°C for water heater operation.
- Warranty limits regarding water chemistry. Harsh water regions – the Rheem warranty may not apply if the water heater is connected to a water supply which: has a Chloride content >250mg/L; a pH <6.0 or >9.5; has a Total Dissolved Solids content >600mg/L; is scaling with a Saturation Index >+0.8, or; is corrosive with a Saturation Index <-1.0.
- Energy savings of up to 66% are based on New Zealand Government approved TRNSYS simulation modelling using a medium load and apply when replacing an electric water heater with a Rheem A55127005 Heat Pump water heater. Any savings will vary depending upon your location, type of water heater being replaced, hot water consumption and fuel tariff.
- Warranty Periods: 7 years supply on cylinder, 3 years labour on cylinder, 3 years on sealed system including labour, 1 year supply and labour on all other parts. Applies to single family domestic dwelling only. Conditions apply. See the Rheem warranty set out in the Owner's Guide and Installation Instructions.
- The specified -5°C to 43°C temperature range limits the unit's heat pump operations, the electric boost element takes over the heat pump operation when the ambient temperature falls outside of this temperature range.
- Noise Level – A noise level of 47 dB(A) was measured at 1 m from the water heater during a Noise Test conducted to Standard GB/T 23137-2008 in a hemi-anechoic chamber within a laboratory. The noise level when installed may be higher due to sound reflections from adjacent walls and structures.

™ Trademark of Rheem New Zealand Ltd

All specifications contained in this brochure are subject to change without notice. Please check the specifications are current at the time of ordering or building to incorporate the appliance. All information is current at the time of publication, (November 2021) but may change without notice.