



ROTARY FAN SPEED CONTROL



PDL

Cat 825F and 825FM Fan Speed Controller

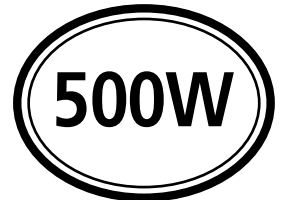
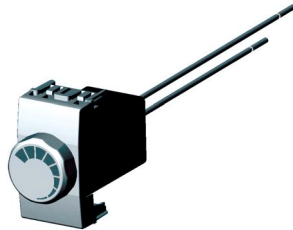
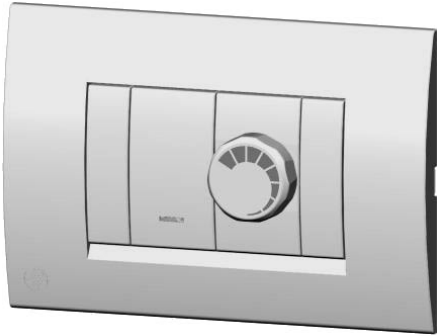

Installation and consumer instructions for Cat 825FM Fan Control Module and Cat 825F Fan Speed Control Switch

OPERATION

The 800 series fan controller provides smooth control of ceiling sweep and exhaust fans. The low profile knob can be adjusted by fingertip to set the desired level of fan speed. The new electronic design of the PDL 825FM eliminates controller buzzing and humming even at minimum fan speed setting, as well as incorporating a kick start feature.

SPECIFICATIONS at 25°C

Supply voltage	230-240 Volts a.c.	Complies with	AS/NZS3100; AS3133 and AS/NZS CISPR15:2002
Frequency:	50Hz	EMC compliant:	☑
Maximum load:	500W (2A)	Approval no:	V41
Minimum load:	40W (0.16A)	Control:	Leading Edge, phase control
Protection:	Thermal overload compensation. Automatically reduces fan speed if overloaded. Overload should be avoided.		

Table 1

Load Type:		Max Load	Comments
Incandescent globes.	X	N/A	Not suitable. Use PDL cat 834L or 834LM
240Volt halogen lighting.	X	N/A	Not suitable. Use PDL cat 834L or 834LM
Resistive loads.	X	N/A	Not suitable. Use PDL cat 834L or 834LM
Low voltage halogen lighting supplied by electronic transformers.	X	N/A	Not suitable. Use PDL cat 824T or 824TM
Low voltage halogen lighting supplied by wire wound transformers.	X	N/A	Not suitable. Use PDL cat 834L or 834LM
Products using ballast or inductors of any type.	X	N/A	Includes fluorescent lighting
Motor speed control.	✓	500W 2A	Exhaust fans (Shaded pole induction motors) Ceiling fans (Split phase induction motors)

WIRING/INSTALLATION INSTRUCTIONS

Mounting:

See 800 Series general fitting instruction sheet

Note:

- 1 Prior to installation ensure the maximum rated load and load type are not likely to be exceeded.
- 2 The dimmer operates in series between phase and load. **Do not** connect supply P&N across dimmer as this will result in damage and void the product warranty.
- 3 Not suitable for inductive loads such as fluorescent lamp loads.

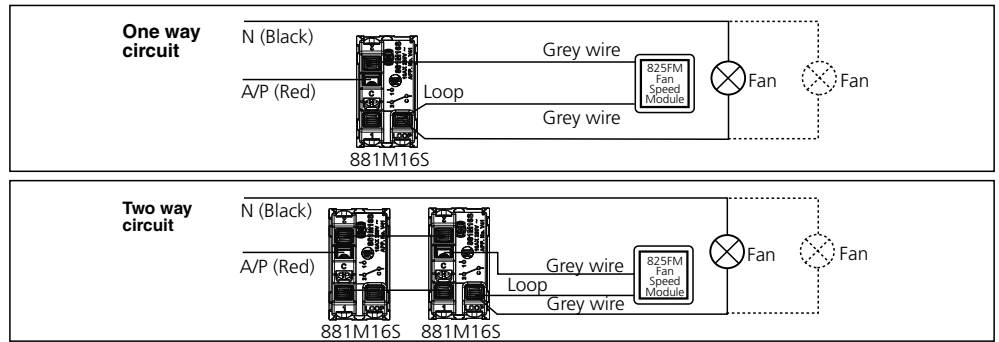

INSTALLATION ONTO PLATE

When installing the control module into the grid ensure that the text on the module case is facing upwards, before clipping into position (see figure 1).

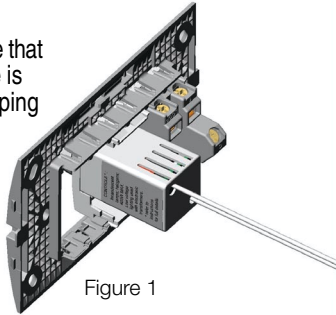

Figure 1

Note:

After installation please ensure a copy of the instructions remain at the installation site.

SETTING MINIMUM FAN SPEED

It is important to set the minimum fan speed before fitting the module knob. When the module is wired up as per the installation instructions and mounted into the surface plate, switch on the power.

- 1 Turn the splined shaft carefully by hand until the desired minimum fan speed is obtained.
- 2 The module knob should then be fitted, ensuring that the thin end of the gradient scale is at the bottom lined up with the vertical (see figure 2).

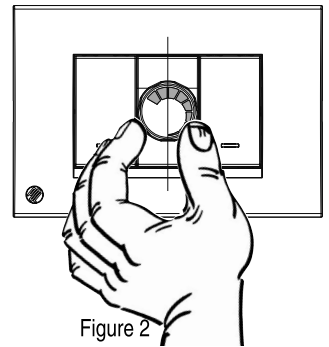

Figure 2

TROUBLESHOOTING GUIDE

Symptom	Cause	Solution
Module hot	Incorrect load type, most possibly excessive load.	Check wiring and load. Refer to specifications table 1.
Fan goes off.	a. Circuit protection operated	Check fuse or circuit breaker and control circuit for overloading
Fan speed slows automatically	Load exceeds 500W	Reduce load to 500W or less
Not operating	Incorrect wiring	Check circuit and correct wiring
Full fan speed range not available	Incorrect positioning of knob	Remove knob and re-check instructions
Interference on circuit or surrounding circuits	Unit subjected to over voltage spikes	Should be checked if problems persists

IMPORTANT

Ensure all work is undertaken by a Registered Electrical trades person only.

WARRANTY

This product is guaranteed for a period of twelve months from the date of purchase against defects in workmanship and materials. Defects will be rectified by replacement of the product purchased except where, at our discretion, minor adjustments can be undertaken.

The guarantee become invalid if in our opinion the product has been misused, abused, incorrectly installed, tampered with, connected to a power supply not corresponding with specifications, or subject to power surges. The guarantee does not include any labour or other associated expenses that may be involved in removal or installation of the product.

To obtain a replacement under this guarantee, return the goods (prepaid) to the place of purchase or direct to the Australian/NZ Distributor. Proof of purchase must be supplied.

This product does not contain any user serviceable parts. Spare parts and repair facilities are not available.

This guarantee is in addition to and does not affect your rights under applicable law except where that law expressly provides otherwise. The consumer Guarantees Act 1993 (NZ) will not apply if this product is purchased for the purpose of business.



New Zealand Head Office:
PO Box 15 355, New Lynn, Auckland, New Zealand
Telephone +64-9-829 0490, Fax +64-9-829 0491
www.schneider-electric.co.nz



PDL Industries Australia Pty Ltd
Locked Bag 5500, Baulkham Hills Business Centre
Baulkham Hills NSW 2153 Australia
Freephone 1300 735 266, Freefax 1300 735 329
Telephone +61 29851 2666, Fax: +61 29851 2695
www.pdl.com.au