



REHAU®

Unlimited Polymer Solutions



RAUPIANO - ACOUSTIC DRAINAGE

Technical Information

Valid from July 2016
Subject to technical modifications
www.rehau.com



**RAUPIANO
PLUS:**
The System
reha.com.au/raupiano

CONTENTS

1	Information and safety recommendations	5
2	System introduction	6
2.1	Application	6
2.1.1	Residential buildings	6
2.1.2	Commercial buildings	6
2.1.3	Trade waste	7
2.1.4	Not suitable applications	7
2.2	Pipe Structure	8
2.3	Fittings	9
2.4	Sound insulation	9
2.5	Marking	9
3	Transportation, storage and handling	10
4	Sound Insulation	11
4.1	Basics	11
4.2	Sound insulation requirements for Australia	12
4.3	Sound reduction with RAUPIANO PLUS	13
4.4	Laboratory testing of sound-insulation behaviour	14
4.4.1	Acoustic testing	14
4.4.2	Acoustic test results	14
5	Fire Protection	16
5.1	Fire-protection requirements	16
5.2	Fire collars	16
6	System Design	17
6.1	General drainage requirements	17
6.2	Equivalent pipe sizes	17
6.3	Specification	17
7	Installation	19
7.1	Cutting and chamfering	19
7.2	Pipe assembly	19
7.3	Bracketing	20
7.3.1	Bracketing plan for horizontal pipes	21
7.3.2	Vertical stack	24
7.3.2.1	Assembly of sound dampening bracket	24
7.3.2.2	Bracketing plan for vertical stack	25
7.4	Floor waste gully installation	26

7.5	P-trap siphon / 110mm disconnecter gully	26
7.6	Cleaning the waste pipe system	27
7.7	Socket plug	27
7.8	Installing pipes in masonry	27
7.9	Installing pipes in concrete	28
7.10	Ceiling penetrations	28
7.11	Installation as stormwater piping	28
7.12	RAUPIANO push-fit lock	29
8	Installation below ground	30
8.1	General	30
8.2	Pipe trench	30
8.3	Embedment	31
8.3.1	Bedding materials	31
8.3.2	Pipe bedding	31
8.3.3	Filling	32
8.3.4	Compacting	32
8.4	Connections to pipes and manholes	32
8.5	Expansion joints in ground	32
9	Adaptation to drainage systems	33
9.1	Drainage fittings to RAUPIANO PLUS	34
9.2	Rubber sleeve adaptor for cast iron pipe or other materials	36
10	Leak test	37
10.1	Hydrostatic test	37
10.2	Air test	37
11	Certifications and test reports	38
12	Technical specifications	39
13	Chemical resistance	40
14	Standards, regulations and guidelines	46
15	Appendix A	47

RAUPIANO PLUS

Information and safety recommendations

1.

Notes on this technical information

Applicability

This technical information is applicable for Australia and New Zealand.

Navigation

At the beginning of this document, you can find a detailed content page which lists the individual chapters and their respective page numbers.

Pictograms and logos



Safety information



Legal information



Important information



Information on the Internet



Advantage



For safe usage of RAUPIANO PLUS, please ensure you are using the latest version of the technical information.

The date of issue of your technical information is always printed at the bottom right of the cover page.

The current technical information is available from your REHAU sales office, or as download on the Internet at www.reece.com.au or www.rehau.com.au or www.rehau.co.nz

- Read the safety recommendations and operating instructions carefully and completely for your own safety and for the safety of other people before starting with the installation.
- Retain the operating instructions.
- If you do not understand the safety recommendations or installation instructions, or if they are unclear, contact your REHAU sales office. Refer to back page for contact details.

Intended use

The system RAUPIANO PLUS may only be installed and operated as described in this technical information. Any other use is unintended and therefore impermissible.



General safety measures

- Observe all applicable national and international regulations on installation, accident prevention and safety, together with the information contained in this manual.
- Keep the work place tidy and free of obstructions.
- Ensure there is always sufficient light.
- Keep children, house pets and unauthorised persons away from tools and installation area. This is especially important in cases of renovation in occupied areas.

Fire protection

Observe the applicable fire-protection regulations very carefully as well as the codes/regulations of building practice that apply in each case, especially in relation to:

- Penetrating through fire compartments.
- Rooms subject to the guideline of places of assembly places.

Personnel requirements

- Allow only authorised and trained persons to assemble our systems.
- Work on pipe components should only be performed by persons trained and authorised for this purpose.

Work clothing

- Wear protective glasses, suitable work clothing, safety shoes, a protective helmet and, if you have long hair, a hair net.
- Do not wear loose clothing or jewellery. They could be caught by moving parts.
- Wear a protective helmet when performing assembly work at head level or above your head.
- Wear NBR gloves when applying lubricant by hand.

When assembling the system

- Always read and comply with the respective operating instructions of the tool used.
- The cutting tools have a sharp blade. The cutting tools are to be stored and handled in a safe way to prevent injuries.
- When shortening pipes, maintain a safe distance between the hand holding the object and the cutting tool.
- Never put your hands near the area where the tool is cutting or on moving parts.
- When performing service, maintenance and alteration work and when changing the place of assembly, always unplug the power cable of the tool and secure it against being switched on inadvertently.

RAUPIANO PLUS

System introduction

ADVANTAGES



- **Excellent sound-insulation properties**
 - Mineral-filled material for pipes and fitting to reduce air-borne noise
 - Partially thickened walls for bend fittings to improve air-borne insulation
 - Special sound-dampening bracket to reduce transmission of structure-borne noise
- **Fast and easy installation**
- **The joint is designed to absorb any thermal expansion**
- **High quality product**
 - Excellent impact resistance - robust for transport, storage and handling at construction site
 - UV-resistance, can be stored outdoor for 1 year
 - Smooth yet abrasion-resistance inner layer to reduce risk of deposits and scaling
- **Green material, non-toxic material without halogen**

2.1 Application

The sound-insulating drainage system RAUPIANO PLUS is suitable for above & below ground installation inside and outside the building structure. This is in accordance with AS/NZS 3500.2 and the NCC Volume 3 as certified under Watermark WM70060 in buildings and WM71503 below ground. Installation must be carried out in accordance with AS/NZS 3500.2 and the National Constructon Code. Observations of DIN EN 12056, DIN EN 752, DIN 1986-100 and DIN EN 1610 are also recommended.

Behaviour in fire corresponds to B2 normal combustibility according to DIN 4102 and D-S3,d0 according to EN 13501-1.

The pipe connections are leak-proof up to an internal excess water pressure of 1 bar (10 m water column). The Push-Fit Lock socket connection allows for a higher pressure of up to 2 bar (20 m water column). See section 7.14 for more information.



2.1.1 Residential buildings



RAUPIANO PLUS is a versatile system for non-pressurized drainage systems which are installed according to AS/NZS 3500.2. It is able to comply with the requirements of Building Code of Australia (BCA) for different types of residential buildings, such as:

- Double storey homes
- Multi-storey apartment blocks
- Condominiums
- Multi storey townhouses

2.1.2 Commercial buildings



RAUPIANO PLUS, with its special acoustic characteristics, can also be installed in commercial buildings that require stricter acoustic requirements such as:

- Hotels
- Office buildings
- Hospitals
- Shopping Centres
- Supermarkets
- Aged Care Facilities

RAUPIANO PLUS meets the increasing need for peace and quiet and ensures a high level of living comfort.

2.1.3 Greasy trade waste



The pipes, fittings and seals can be operated continuously at 90°C (and up to 95°C for brief periods). They are suitable for the drainage of chemically aggressive waste water with a pH value of 2 (acidic) to 12 (basic). Please refer to chemical resistance list.

RAUPIANO PLUS is ideal for drainage of greasy waste water from commercial kitchens up to the grease separator.

For lengthy grease waste lines, the use of pipe trace heating may be necessary. This prevents premature grease accumulation. The temperature of the pipe trace heating suitable for plastic pipes may not exceed 65°C. Refer to chemical resistance chart in chapter 13.

2.1.4 Not suitable applications

Pipes and fittings may not be used for:

- installation subjected to continuous operating temperature higher than 90°C (or higher than 95°C for brief periods)
- carrying waste water containing prohibited chemicals (see section 12 and 13)
- exposed installation to UV radiation (e.g. sunlight) directly and indirectly
- fuel stations
- oil discharge

If used in cold areas, where installations are commonly done under temperature below -10°C, additional tests are required according to AS/NZS 7671.

RAUPIANO PLUS has passed the test and therefore marked with the “ice crystal” according to AS/NZS 7671 and DIN EN 1411 and can be installed in these regions.



RAUPIANO PLUS is not suitable for siphonic drainage systems. For outlet of ventilation lines, use pipes suitable for outdoor installation instead of RAUPIANO PLUS.



Observe all applicable national and international regulations on installation, accident prevention and safety, together with the information contained in this manual.

Areas of application which are not included in this technical information (special applications) require consultation with our technical department. Please contact your REHAU sales office.

2.2 Pipe structure

The RAUPIANO PLUS multi-layer pipe construction achieves superior properties through the application of distinct functional layers combined in a composite construction.

Three separate layers impart unique characteristics to the pipe. The abrasion resistant, low friction inner layer ensures the easy transit of waste. The mineral filled mid-layer ensures superb sound dampening properties and also offers increased stiffness. Finally, the robust outer layer is tough enough to withstand impacts and shocks.

Together, the composite layers create a tough, durable pipe, with outstanding acoustic properties that provides all the functionality of a drainage pipe system combined with the noise absorption properties of lagging.

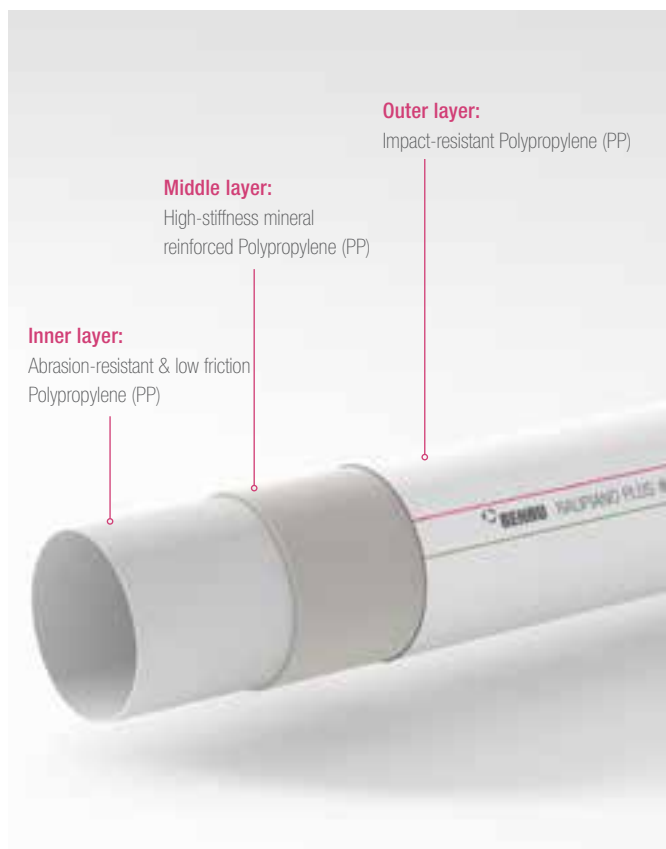

Fig. 2-1 RAUPIANO PLUS pipe structure.

FEATURES

- Multi-layer pipe system:
 - Smooth yet abrasion-resistant inner layer made of PP
 - Rigid middle layer made of PP with sound-dampening minerals
 - Impact resistance and UV-stabilized outer layer made of PP
- Built-in push-fit socket with factory-fitted sealing ring providing flexible and vibration-resistant joints
- Temperature resistance up to 95°C
- Chemical resistance from pH 2 – 12. Refer to Chapter 12 and 13
- High ring stiffness
- 100% recyclable

ADVANTAGES

- State-of-the-art sound insulation technologies, no acoustic-lagging required
- Suitable for special applications requiring high temperature and chemical resistance such as trade waste. Please refer to chemical resistance list.
- Green system due to low energy production and 100% recyclability
- Simple and fast installation
- 100% leak-proof connection
- Flexible joint suitable for tremor-prone areas
- Fracture resistant at -10°C.
- Uncompromising fire-protection solutions
- Can be stored outdoors for up to 1 year.
- Complete pipe, fitting, adapters and bracket range



RAUPIANO's ideal characteristics are achieved thanks to the three-layer structure of the pipe and the specialised adaptation of each individual layer to its respective requirement:

- High ring stiffness
- Excellent impact strength of the outer layer at low temperature
- Increased UV-resistance
- Abrasion-resistant and smooth inner layer
- Highly rigid and sound-insulating middle layer made of mineral reinforced PP

2.3 Fittings

Redirections in water flow at bends causes increased turbulence which results in greater air-borne sound transmission.

RAUPIANO PLUS bends from size DN110 to DN160 consist of targeted mass optimisation zones which help to reduce sound transmission in these areas.



Fig. 2-2 RAUPIANO PLUS bend with reinforced impact area.

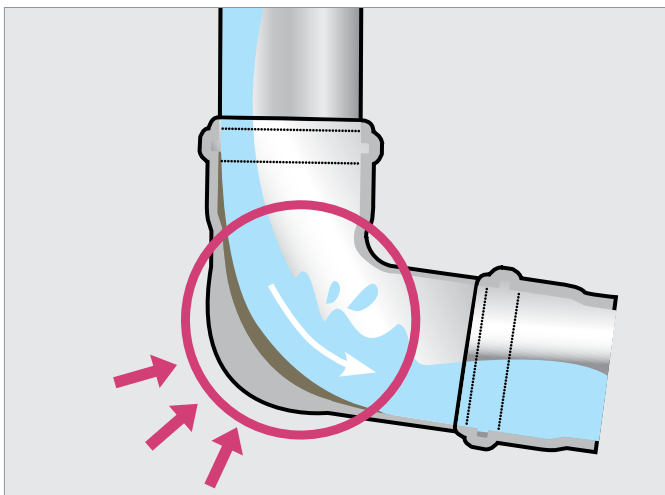

Fig. 2-3 Specially designed bends with increased wall thickness reduce air-transmitted sound even further.

2.4 Sound insulation

The sound-insulating drainage system RAUPIANO PLUS offers quality, quietness and living comfort in important areas of a building. RAUPIANO PLUS system has been independently tested by Renzo Tonin and Associates, a member of the Association of Australian Acoustical Consultants (AAAC) at the National Acoustic Laboratories (NAL). Test results were assessed by a separate AAAC member to ensure impartiality of the report. The report found conclusively that RAUPIANO PLUS pipe system exceeds the $R_w + C_{tr}$ 40 requirement of the National Construction Code Vol.1 / Building Code of Australia, and that a stand alone RAUPIANO PLUS system is comparable, in terms of sound insulation, to a fully lagged PVC system behind a specified ceiling separation. Refer to Chapter 3 Sound insulation.

The acoustic test letters from the assessing acoustic engineers are available in the Appendix A.

2.5 Marking

Pipes and fittings are marked with the following:

- Watermark
- Manufacturer's mark
- Approval number
- Mark of quality
- Ice crystal (AS/NZS 7671 and DIN EN 1411)
- Nominal diameter (DN)
- Year of manufacture
- Production line
- Material
- Distance markers
- Angle specification (with elbows and branches)

RAUPIANO PLUS

Transportation, storage and handling

3.

TRANSPORTATION

RAUPIANO PLUS proves its robustness during transport and at the construction site thanks to its three-layer structure and impact-resistant and shock-proof outer layer. Ensure that pipes make firm contact over their entire length.

STORAGE

- Protect boxes from moisture during transport and storage.
- RAUPIANO PLUS and its seals can be stored outdoors for up to 1 year

We recommend:

- Protecting RAUPIANO PLUS pipes and fittings from direct sunlight and soiling by:
 - storing in the box
 - covering them with tarpaulins (ensure proper ventilation).
- Stack no more than four wooden crates on top of one another.

- Ensure that the wood frames are aligned squarely when stacking.
- Store pipes in such a way that no objects are placed on top of or in the sockets and male ends and that these are not deformed.

RAUPIANO DELIVERY PROCEDURE

Key points to remember:

- Treat RAUPIANO with care to avoid damage.
- Take pipe out of bags prior to delivery to check condition. Put back in bag if possible.
- Do not over tighten the ratchet on the ute.
- Pipe can still be used with small indentations as long as both the male and female ends are not damaged and the O-ring is in place.

CORRECT TRANSPORTATION PROCEDURE

Where possible use a truck for deliveries.
Lay pipe flat on the tray

Keep pipe strapped down so it doesn't roll around and remains supported

Alternate socket and pipe ends when loading pipe

WHAT NOT TO DO

Do not throw pipe into the tray

Do not throw pipe off the ute

Do not over tighten with ratchet

Take care with O-rings and ensure they are in good condition

Unsupported pipes can bend

Keep pipes clear of building debris whilst on site

Fig. 2-4 Transporting of RAUPIANO PLUS

RAUPIANO PLUS

Sound insulation

4.

4.1 Basics

In every area of building construction, especially the construction of multi-storey apartment blocks, hospitals and rehabilitation homes, sound insulation plays an increasingly important role. One of the most significant sources of sound within buildings is the sanitation set-up and the accompanying drainage water pipe system.

Typical sources of sound include:

- Fitting noises
- Filling noises
- Draining noises
- Inlet noises
- Impact noises
- Turbulance

Unsuitable drainage pipe system and type of brackets are considerable contributors to disturbing noise. RAUPIANO PLUS, a system-tested, versatile sound-insulating drainage water system addresses these concerns.

A differentiation is made between air-borne noise and structure-borne noise.

Air-borne noise

Air-borne noise is present if the noises of a sound source are transferred directly through the air to human ears.

Structure-borne noise

With structure-borne noise, the sound transfer first occurs through a solid body. This body vibrates and passes the vibrations on to human ears as airborne noise.

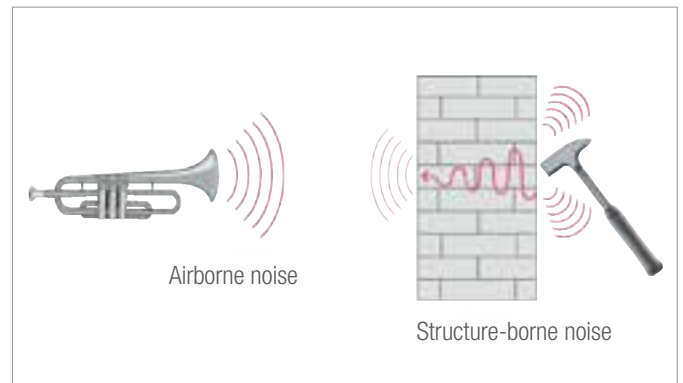

Fig. 4-1 Air-borne and structure-borne noise.

RAUPIANO PLUS

Sound Insulation

4.2 Sound insulation requirements for Australia

Sound insulation requirements differ from country to country and from one building type to another. In Australia the NCC / BCA Volume One Part F5 outlines the requirements for sound insulation:

- F5.6 Sound insulation rating of services

NCC/BCA Acoustic requirement

The NCC / BCA specifies that if a pipe that is located in a wall or floor cavity, serves or passes through more than one sole-occupancy unit, the pipe must be separated from the rooms by construction with an $R_w + C_{tr}$ of:

- 40 if the adjacent room is habitable (other than a kitchen); or
- 25 if the adjacent room is a kitchen or non-habitable

For the Northern Territory:

- R_w 45 if the adjacent room is habitable (other than a kitchen); or
- R_w 30 if the adjacent room is a kitchen or non-habitable

Weighted sound reduction index (R_w) is the number used to rate the effectiveness of a system as a noise insulator. An increase in one R_w unit approximately equals a reduction of one decibel in noise level.

Weighted sound reduction index plus spectrum adaptation term ($R_w + C_{tr}$) takes into account the lower frequency noise. C_{tr} is a negative number, so $R_w + C_{tr}$ value will always be lower than R_w value.

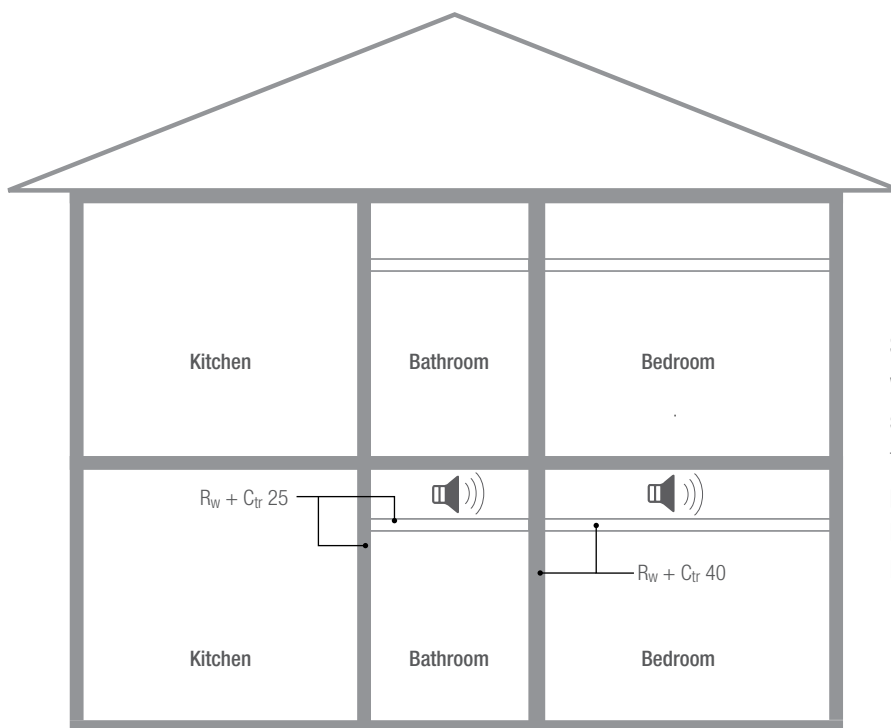

Separation between the noise source (water/waste) and the habitable room must have a sound reduction level of $R_w + C_{tr}$ 40 according to NCC/BCA Volume 1 Class F5.6 for services passing through habitable rooms. For the Northern Territory a sound reduction level of R_w 45 is required.

Fig. 4-2 NCC/BCA Acoustic requirement.

4.3 Sound reduction with RAUPIANO PLUS

Both structure-borne and air-borne noises occur in drainage pipe systems. The wall of the pipe vibrates due to water currents and flow noises. The type and intensity of these pipe vibrations depend on a variety of factors, such as the mass of the pipe, the pipe material, its inner sound dampening material and installation method.

The pipe vibrations are emitted directly from the pipe as air-borne noise and are transferred as structure-borne noise via the pipe brackets to the wall.

When developing a sound-insulating drainage water system, both types of noise distribution must be taken into account.

Airborne noise insulation with RAUPIANO PLUS

Airborne noise is reduced by RAUPIANO PLUS due to special materials, sound-dampening minerals and increased weight of the pipe system. Targeted mass optimisation in sound-sensitive areas of fitting elbows of nominal diameter DN 110 to DN 160 provides further improvement at redirection points.

Structure-borne noise insulation with RAUPIANO PLUS

The transmission of structure-borne noise to the wall is reduced with RAUPIANO PLUS with the use of patented, sound dampening brackets:

- A supporting bracket with loose gap in the pipe is fastened to the wall
- A fastening bracket rests onto the supporting bracket, keeping the pipe in position

This extensive physical decoupling of the pipe, bracket and wall means that the transmission of structure-borne noise is eliminated to a high degree (see Chapter 7 for installation details).

UNPROTECTED PIPEWORK

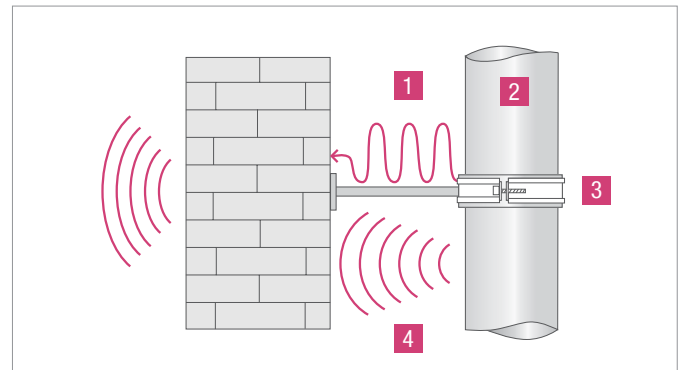

Fig. 4-4 Sound distribution with sewer pipe systems.

- 1 Structure-borne noise
- 2 Standard drainage pipe
- 3 Standard bracket (pipe bracket with/without rubber ply)
- 4 Airborne noise

PROTECTED PIPEWORK

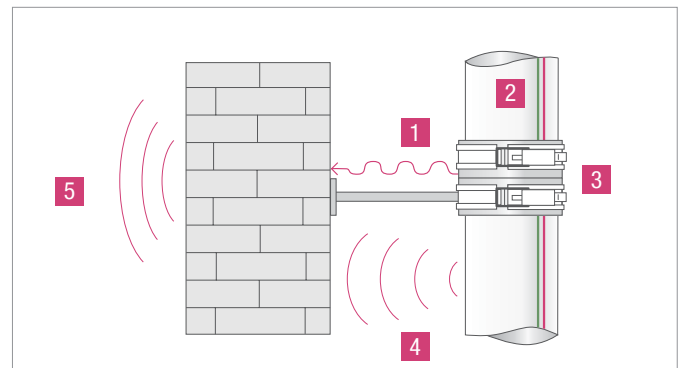

Fig. 4-5 Sound insulation with RAUPIANO PLUS.

- 1 Reduction of structure-borne noise
- 2 RAUPIANO PLUS pipe with sound-dampening fillers
- 3 RAUPIANO PLUS bracket, patented sound-dampening support bracket
- 4 Reduction of airborne noise
- 5 Reduced overall noise level

RAUPIANO PLUS

Sound Insulation

4.4 Laboratory testing of sound-insulation behaviour

4.4.1 Acoustic testing

Acknowledging the different installation practices and the effects on acoustic level reading in the building, REHAU engaged several acoustic consultants to perform extensive acoustic tests on RAUPIANO PLUS drainage system under different configurations. The acoustic tests were performed in:

- National Acoustic Laboratory (NAL) by Renzo Tonin & Associates
- McLay Industries Facility (MIF) by ASK Consulting Engineers
- Technical and Further Education South Australia (TAFE SA) by AECOM

RAUPIANO PLUS pipe system has been independently tested using an established acoustic industry test based on ISO 140 testing methodology and independently rated to ISO 717, then assessed in accordance with the requirements of NCC/BCA.

To ensure close proximity to real-life noise, full-toilet flush was used during measurement. Full-toilet flush represents the worst-case scenario in domestic drainage environment. The water swirling and turbulence from toilet flush, and therefore the noise created by them, cannot be replicated by any other noise source such as continuous water flow.

4.4.2 Acoustic test results

In Australia and New Zealand, buildings can be classified into two categories:

- For buildings regulated by NCC/BCA
- For buildings not regulated by NCC/BCA

Our extensive acoustic test results provide the necessary data for both categories.

Buildings not regulated by NCC/BCA

The acoustic requirements of buildings outside of NCC/BCA's scope tend to be different. The rooms are normally classified differently, and therefore have different noise level requirements. The L_{Amax} and the L_{Aeq} values are more of important values than R_w+C_{tr}.

RAUPIANO PLUS has gone through extensive acoustic testing with different ceilings, ranging from flush plasterboard to Rondo ceiling grid system with lay in tiles, and with different plasterboard thicknesses.



From very extensive raw data collected through real-life acoustic tests, AECOM assessed the acoustic performance of RAUPIANO PLUS and it was positively concluded that RAUPIANO PLUS achieves R_w + C_{tr} 40 (R_w 46) with 10 mm plasterboard. That means RAUPIANO PLUS satisfies BCA's acoustic requirements for habitable and non-habitable areas with just 10 mm plasterboard, without penetrations, lagging and insulation batt.



The acoustic assessment letters from the acoustic consultants (Renzo Tonin & Associates, ASK Consulting Engineers, and AECOM) can be found in the website's download section under www.rehau.com.au/raupiano and www.rehau.co.nz/raupiano. The complete test reports can be provided upon request.

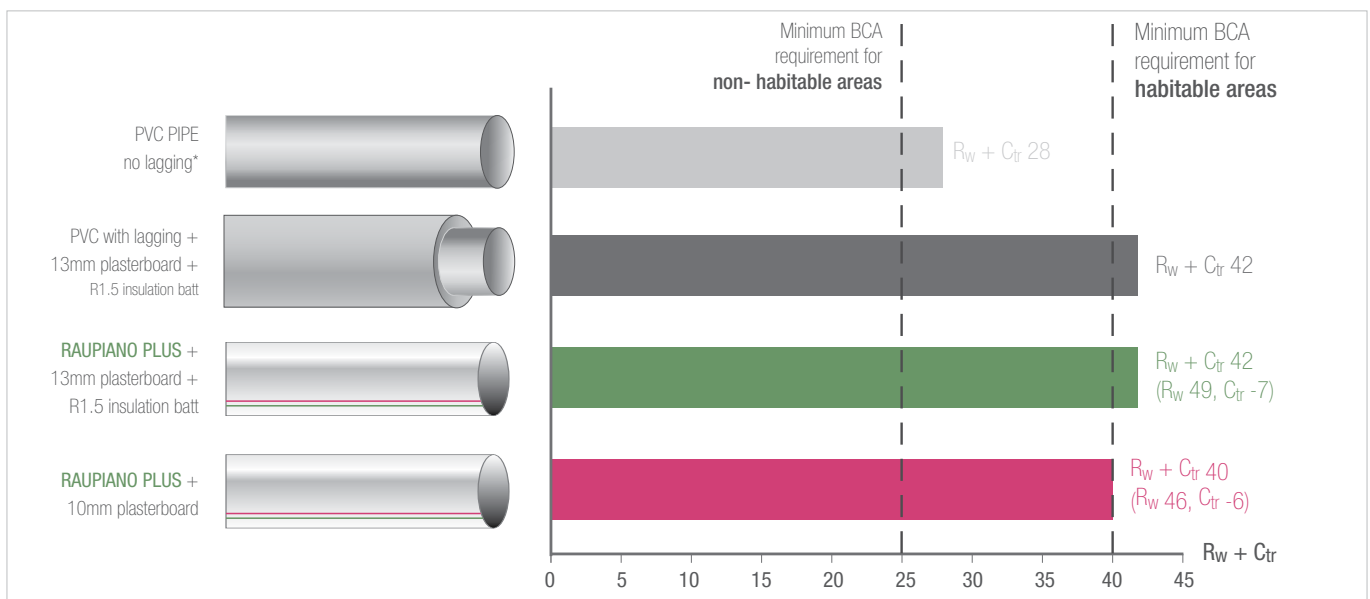

Acoustic testing

* Boral Selector + Feb 2009 - System WP13, 13mm std core plasterboard with insulation (Graeme E Harding & Associates)



RAUPIANO PLUS performance is confirmed once a ceiling is in place. Exposed RAUPIANO PLUS installation can compromise the acoustic performance.

To ensure full compliance to the NCC/BCA acoustic requirements, the following configurations are recommended:

RAUPIANO PLUS Achievements

$R_w + C_{tr}$ 25 (non-habitable areas)

$R_w + C_{tr}$ 40 (habitable areas)

$R_w + C_{tr}$ 42 (habitable areas)

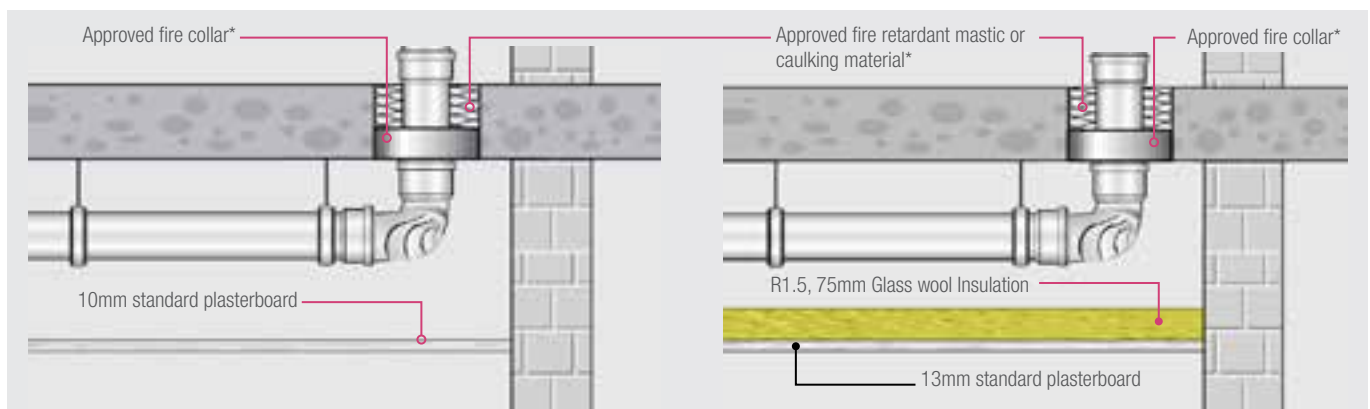

Fig 4-7 Recommended suspended ceiling configurations to comply with NCC/BCA acoustic requirements

* The above schematic shows a general example and is not intended to satisfy the installation requirements for any particular project. Specific fire protection measures may or may not be required depending on building class and design, check with fire engineer and refer to the National Construction Code for detailed information.

Buildings not regulated by NCC/BCA

The acoustic requirements of buildings outside of NCC/BCA's scope tend to be different. The rooms are normally classified differently, and therefore have different noise level requirements. The L_{Amax} and the L_{Aeq} values are more of important values than $R_w + C_{tr}$.

RAUPIANO PLUS has gone through extensive acoustic testing with different ceilings, ranging from flush plasterboard to Rondo ceiling grid system with lay in tiles, and with different plasterboard thicknesses.

- RAUPIANO PLUS produces lower noise levels compared to lagged PVC and lagged HDPE when the suspended ceiling is installed with insulation batt

- RAUPIANO PLUS produces lower noise levels compared to lagged PVC when it is installed in wall cavity (vertical stack pipe), when the wall cavity is installed with insulation batt.

- RAUPIANO PLUS produces noise levels within 3 dB(A) compared to lagged PVC and lagged HDPE when the suspended ceiling is installed without insulation batt. This noise difference is not noticeable by human ear.



RAUPIANO system shall be decoupled from all other structures, materials and services to minimize sound transmission.



The acoustic assessment letters from the acoustic consultants (Renzo Tonin & Associates, ASK Consulting Engineers, and AECOM) can be found in the website's download section under www.rehau.com.au/raupiano and www.rehau.co.nz/raupiano. The complete test reports can be provided upon request.

RAUPIANO PLUS

Fire protection

§

The behaviour of RAUPIANO PLUS in a fire corresponds to material class B2 (normally inflammable) in accordance with DIN 4102, Part 1.

5.1 Fire-protection requirements

With regard to drainage pipes, fire-protection measurements may be necessary if pipes penetrate through fire-rated building elements in a building.

§

With regard to fire protection, the applicable national regulations and the valid codes/regulations of building practice are to be observed.

5.2 Fire collars

RAUPIANO PLUS system can be installed with suitable fire collars which have been tested and proven according to AS 1530.4 to fulfill the fire protection requirements from NCC/BCA.

For fire protection of penetrations through fire-rated ceilings and walls, it is compulsory to install suitable fire collars that will not reduce the fire-rating of the particular building elements.

Avoid direct contact between RAUPIANO PLUS pipe and the building element to avoid transmission of structure-borne noise into the building element. Use fire rated soft caulking material to close gaps between the fire collar and the pipe. The caulking material must be tested and approved by the manufacturer of the fire collar to be installed together with RAUPIANO PLUS pipe.

We recommend to always get an approval from the responsible construction authority for compliance with the respective requirements.

Some Fire Collar Manufacturers have approved results with RAUPIANO Pipe in the fire collar and some have with the pipe and socket in the fire collar. Refer to fire collar manufacturers for this detail.



Wall penetrations require two collars (on both sides of wall).
All floor waste gullies require specific fire protection collars.

§

- When planning and assembling fireproof collars, the requirements of the general building construction approval and the specifications of the assembly instructions must be observed.
- When using fireproof collars, the applicable national regulations must be observed.

Approved fire collar solutions for RAUPIANO PLUS pipe are available from the following manufacturers:

- Promat (1800 776 628 or www.promat.com.au)
- Ramset (1300 780 063 or www.ramset.com.au)
- Snap (1300 76 46 26 or www.snapcollars.com.au)
- Hilti (131 292 or www.hilti.com.au)
- Allproof (+64 9 481 8020 or <http://allproof.co.nz>)

IMPORTANT: Not every fire collar is tested and approved with RAUPIANO PLUS

Contact the manufacturer of the fire collar for information on fire test results and assembly/installation instructions to determine which solution suits your requirements.

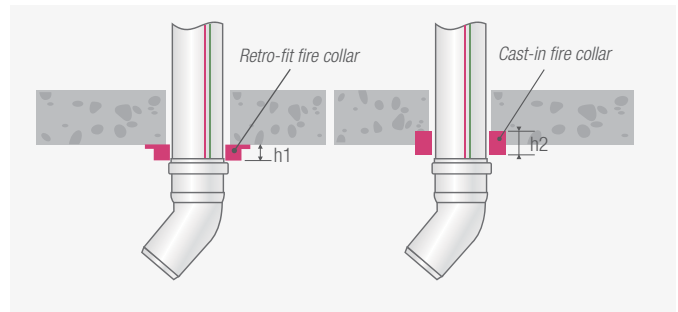

Fig. 5-2 Installation of fireproof collar in ceiling*

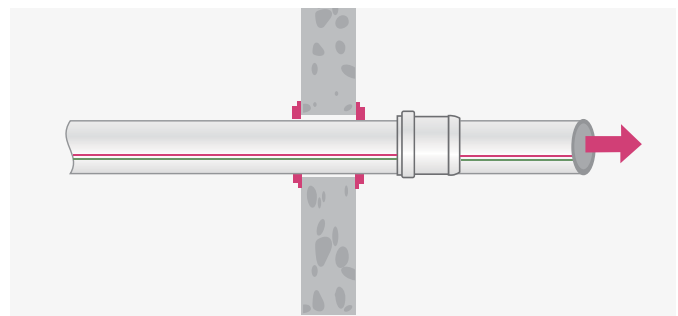

Fig. 5-3 Installation of fireproof collar on wall*

* General example only. Refer to fire collar manufacturer for installation details.

RAUPIANO PLUS

System design

6.

6.1 General Drainage Requirements

The design and installation of RAUPIANO PLUS drainage system shall comply to AS/NZS 3500.2.

The goal is to ensure intended functioning of the universal drainage system RAUPIANO PLUS, i.e.

- Back siphoning and leaking of water seal column must be prevented
- Ventilation of the drainage system must be ensured
- Nominal diameter larger than those calculated are not to be used to ensure effective drainage
- Sewage must drain with little noise
- Anaerobic digestion is to be prevented
- Gas emissions are to be lead out without harmful effects via the main ventilation system

6.2 Equivalent pipe sizes

Pipe sizing chart

PVC		RAUPIANO PLUS	
DN	OD (mm)	DN	OD (mm)
40	43	40	40
50	56	50	50
65	69	75	75
100	110	110	110
150	160	160	160

Table 6-1 Equivalent pipe sizes.



When connecting RAUPIANO PLUS directly to PVC systems, some dimensions require connection adapters. Refer to chapter 9 for details.

6.3 Specification

General

RAUPIANO PLUS system is suitable for acoustic drainage, acoustic stormwater and trade waste application. It can be installed inside the building and below ground.

Standards

NCC/BCA	National Construction Code / Building Code of Australia
NZBC	New Zealand Building Code
AS/NZS 3500.2	Plumbing and drainage – Sanitary plumbing and drainage
AS/NZS 7671	Plastic piping systems for soil and waste drainage (low and high temperature) inside buildings - Polypropylene (PP)
AS/NZS 5065	Polyethylene and polypropylene pipes and fittings for drainage and sewerage applications

Approval in Australia and New Zealand

Pipes and fittings are certified under Watermark Certificates WM70060, WM71501 and WM 71502 for sizes DN 40 to DN 200 and also under WM 71503 for sizes DN110 to DN200. System shall have BRANZ approval in New Zealand.

System design and performance

Planning, installation and commissioning are to comply with AS/NZS 3500.2 and RAUPIANO PLUS - THE VERSATILE ACOUSTIC DRAINAGE AND TRADE WASTE SYSTEM - INSTALLATION AND TECHNICAL MANUAL.

System component – Pipes and Fittings

Pipe materials shall be composite polypropylene RAU-PP, consisting of polypropylene inner layer, mineral-filled polypropylene middle layer and UV-stabilised polypropylene outer layer, complying with AS/NZS 7671 for gravity drainage and stormwater drainage system in residential and commercial applications.

Fitting materials shall be mineral-filled polypropylene for acoustic performance enhancement, complying with AS/NZS 7671 for gravity drainage and stormwater drainage system in residential and commercial applications.

Pipes and fittings shall be designed for an operating temperature of 90°C and shall temporarily withstand temperatures of up to 95°C and marked with ice crystal to indicate suitability for installations under extreme low temperatures up to -10°C. They shall have excellent chemical resistance and withstand acidity level from pH 2 - 12. The packing shall be done to reduce the effect of UV radiation on the pipe and fitting material and to protect them from dirt and other foreign materials.

System component - Sound-dampening bracket

Sound-dampening bracket shall be rubber-lined with vibration-decoupling system to reduce the structure-borne noise transmitted from the RAUPIANO PLUS system.

System component - Floor Waste Gully

Floor Waste Gully material shall be polypropylene RAU-PP. The Floor Waste Gully shall have 1 main inlet in dimension DN (OD) 110mm with socket and 3 additional inlets in dimension DN (OD) 50mm. The outlet shall be of dimension DN (OD) 75mm. Floor Waste Gully shall have a removable inserted baffle. The total height shall be 222 mm.

Connections

The connections between the polypropylene pipes and fittings shall be of leak-proof push-fit socket connection with Styrene Butadiene Rubber (SBR) sealing ring. The connections shall be able to withstand internal pressure of up to 100 kPa and accommodate thermal expansion.

RAUPIANO PLUS

Installation

7.



All schematics show general examples only and are not intended to satisfy the installation requirements for any particular project. For the installation of RAUPIANO PLUS waste water piping system, national and local codes, rules and regulations, as well as local conditions and the demands of the end use customer need to be considered.

7.1 Cutting and Chamfering

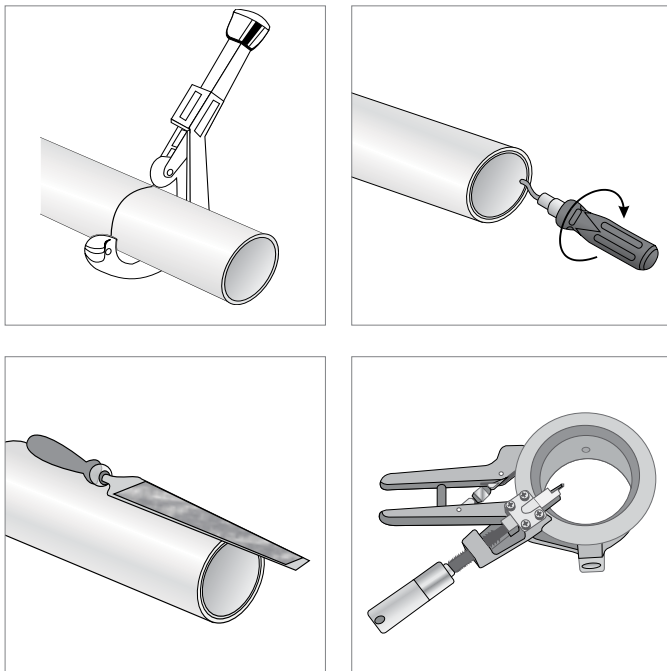

1. Cut the pipes with common pipe cutters or a fine-toothed saw.
2. Make a cut at 90° angle from the pipe axis.
3. De-burr the inner diameter of the pipe.
4. For connections to push-fit socket pipe systems, taper the pipe ends with a tapering tool (i.e. Rothenberger Rocut tool <Reece code 7705255> for pipes DN40 to DN110 or a coarse file at an angle of approximately 15°).



Fittings shall not be cut.

7.2 Pipe Assembly

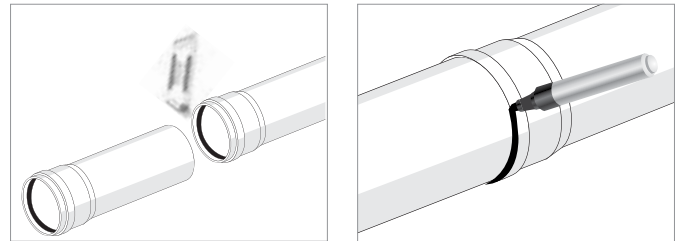

1. Clean dirt from sealing ring, socket interior and pipe end.
2. Use small amount of RAUPIANO lubricant (eg. a 10mm drop) to moisten male end and O-ring and slide into the socket until it stops.
3. Mark inserted male end in this position at the socket edge with a pencil, pen etc.

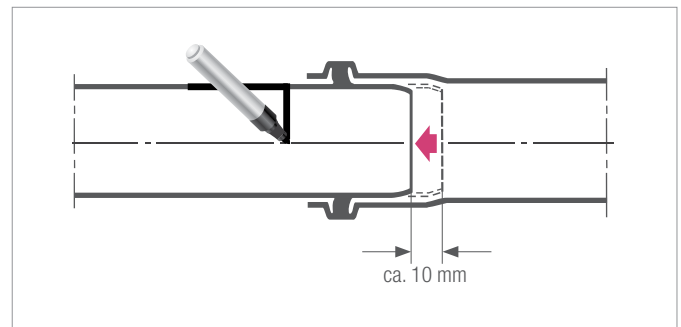

Fig. 7-1 Pulling out pipe ends for expansion joints.

To accommodate thermal expansion of RAUPIANO system, the following conditions are recommended. Ensure witness mark is visible to ensure that the pipe is not accidentally pulled out.

Insert fully and pull out 10mm per pipe for:

- Pipes longer than 500mm;

Insert spigot end fully into socket for:

- Pipes shorter than 500mm;
- In ground applications;
- Fitting to fitting.



Below ground installation

When the pipe is installed below ground it is **not** required to pull the male end out by 10mm to provide an expansion joint.

Each RAUPIANO PLUS pipe socket can accept the changes in length of a waste pipe up to 3 m in length (coefficient of linear expansion in accordance with DIN 53752 averages 0.09 mm/(m·K) at 0°C to 70°C).

7.3 Bracketing



Sound-dampening bracket

- Minimizes transmission of vibrations from pipe through fixing into wall.
- Consists of loose and tight bracket:
 - lower bracket (loose) attaches to wall and de-couples pipe vibrations from wall fixing.
 - upper bracket (tight) supports pipe.
 - attach to vertical stack only 1 required per floor, per stack
 - REHAU proprietary

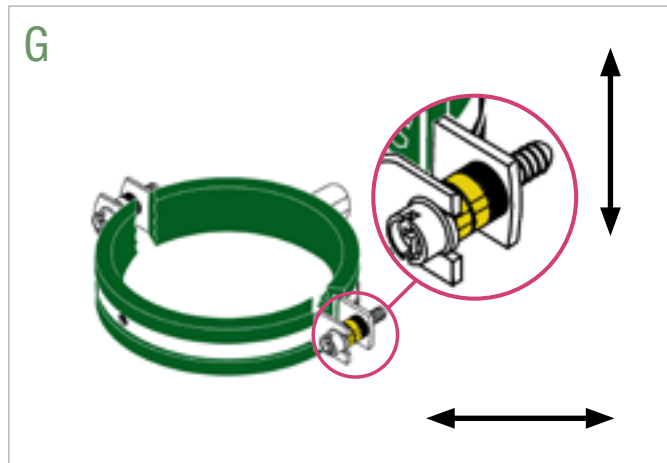

Guiding bracket

- Model: Bifix 5000
- Allows for thermal expansion of the pipe
- Always loose on pipe (has spacer)
- Fix to ceiling on horizontal pipes
- Fix to wall on vertical stack
- Insert 1 yellow spacer per side
- Walraven or REHAU approved



Fixing/security bracket

- Model: Bifix 1301
- Always tight on pipe
- When used as fixing bracket on horizontal pipes: fix to ceiling
- When used as security bracket in vertical stacks: never fix to wall
- Walraven or REHAU approved

7.3.1 Bracketing plan for horizontal pipes

Pipe size (DN)	Collar OD (mm)	Pipe thickness (mm)	Pipe ID (mm)	Maximum recommended bracket spacing (mm)
40	52.8	1.8	36.4	15 x OD (600mm)
50	62.8	1.8	46.4	15 x OD (750mm)
75	87.9	1.9	71.2	10 x OD (750mm)
110	125.6	2.7	104.6	10 x OD (1100mm)
160	180.7	3.9	152.2	10 x OD (1600mm)

- A plan for effective bracketing of a horizontal sound-insulating pipe with RAUPIANO PLUS is displayed in 7.5.1.
- It is recommended to have fixed brackets as close to the pipe socket as possible to support the joint.

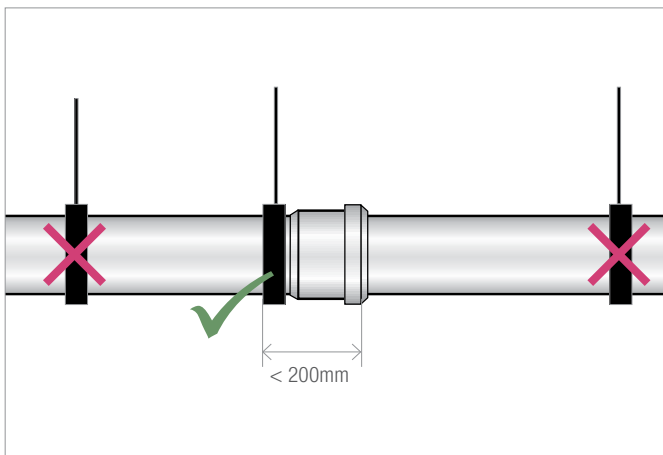

i Sound-dampening support brackets are not required for horizontal pipe installations.

Fixing bracket hold pipe in place. Guiding bracket allow for thermal expansion in one direction.

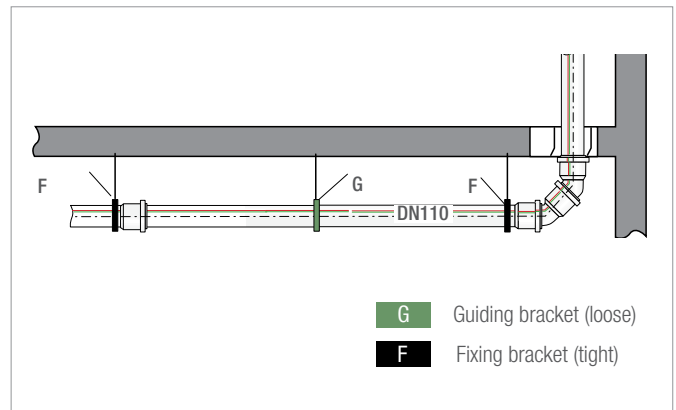

Fig. 7-8 Bracketing plan for horizontal pipes

- i** - Don't use sound-dampening bracket on horizontal lines.
- Install fixing bracket at socket end followed by guiding bracket until next joint.
- Install fixing bracket downstream, as near as possible to the socket end.
- If more than 3 fittings are joined together in the same line, ensure the group of fittings are sufficiently supported to avoid sagging, twisting and to prevent the connections from sliding apart.
- Recommended bracket spacing for all pipe sizes are shown in table 7.5.1
- REHAU sound dampening brackets and Walraven brackets were use for all acoustic tests. The use of other brackets with different properties may compromise the acoustic performance of RAUPIANO PLUS.

Configuration of brackets depends on length of pipe. Always only 1 fixing bracket per pipe.

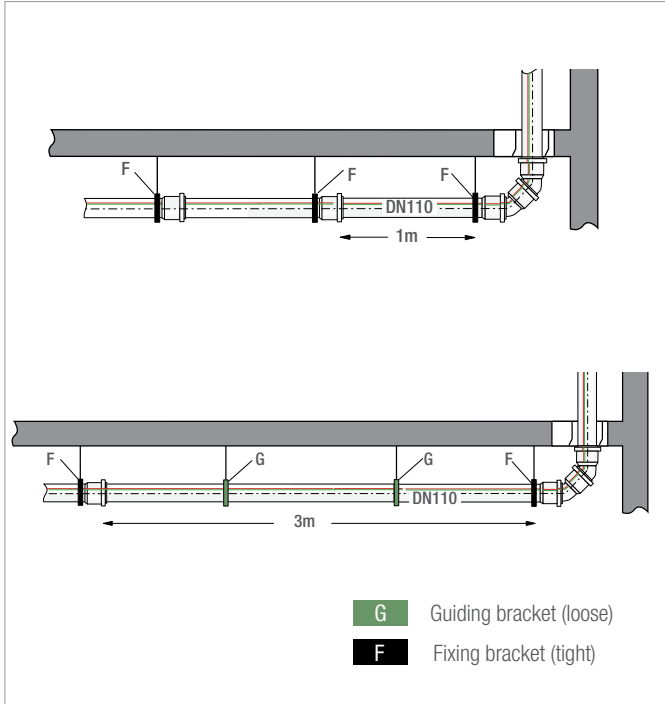

Fig. 7-9 Bracketing plan for horizontal pipes

If fitting prevents bracketing at 10 x D, reduce spacing.

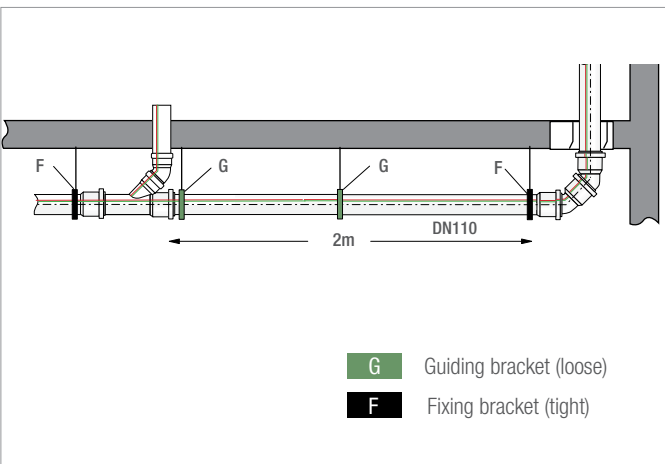

Fig. 7-10 Bracketing plan for horizontal pipes

Anchor brackets

Anchor brackets are recommended when distance between the ceiling and top of pipe is greater than 300mm.

Anchor brackets (ie. tri-brackets) are required in the following applications:

- Every 6m or less in a straight run; or
- Every 4m if temperature exceeds 60°C;
- Every change in flow direction;
- All junctions where the branch pipe length exceeds 2m (normal applications) and 1m (where temperature exceeds 60°C);
- Where a branch enters a stack and where a stack rolls over.

This is a recommended solution and is not seismic tested.

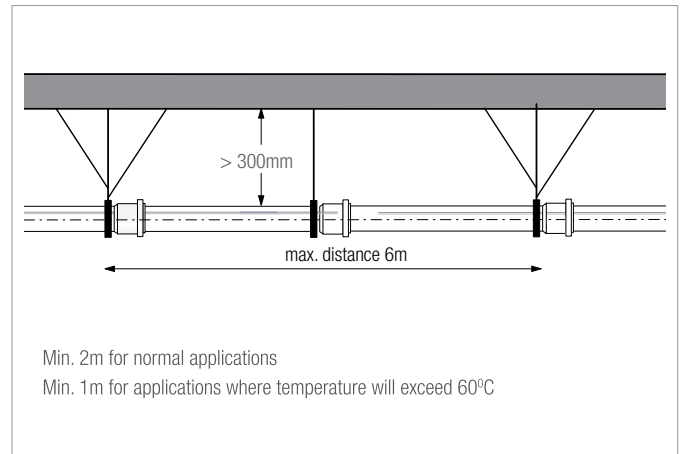

Providing fixed supports using tri-bracketing (Guiding brackets not shown in image)

 Please check with your local authorities for when cases are different



Fixed bracket with Unistrut

Bracket Adjustment

To assist in the adjustment of brackets to provide the gradient required, a "Z" bracket (Reece code 506514) is an alternate solution.

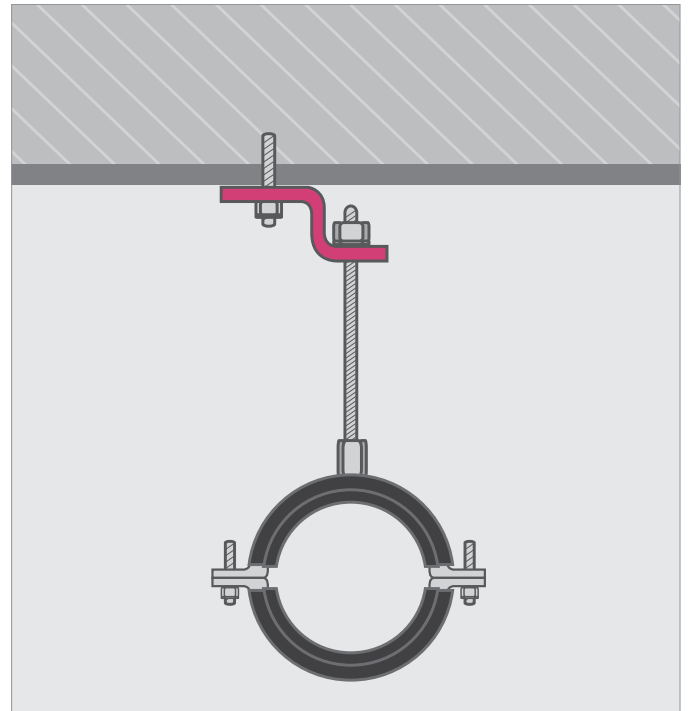

Z-brackets

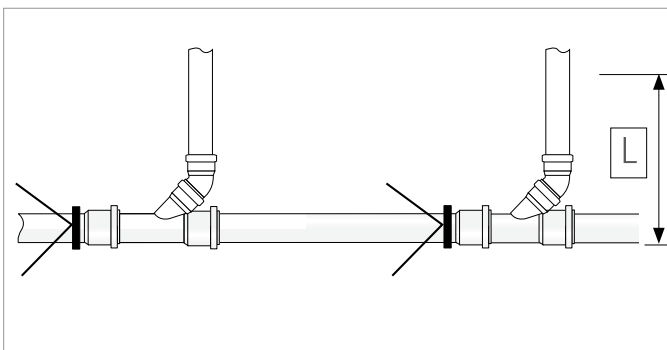

Anchor Brackets

Tri-bracketing plan view (view from top)

L= Min. 2 m for normal applications,

Min. 1 m for applications where temperature will exceed 60 °C



Anchor Brackets / Tri-brackets example

7.3.2 Vertical stack

To achieve optimum acoustic insulation, use only RAUPIANO PLUS sound dampening brackets during assembly.

RAUPIANO PLUS drainage pipes must be installed tension-free.

7.3.2.1 Assembly of Sound Dampening Bracket

The patented sound-dampening support bracket consists of a supporting bracket (loose) and a fastening bracket (tight, sits above supporting bracket). One sound-dampening support bracket per floor is sufficient.

1. Fit fastening bracket around the pipe and close it.



Fig. 7-14 Fastening bracket, secured around pipe

2. Assemble supporting bracket on masonry.



Fig. 7-15 Supporting bracket assembled, opened.

i A spacer is attached at the closure of the support bracket to prevent the bracket being closed completely. This ensures minimum transmission of structure-borne noise to the wall.

3. Open supporting bracket, insert pipe with fastening bracket and close supporting bracket.



Fig. 7-16 Closing supporting bracket.

After installation, the fastening bracket fully lies on the supporting bracket. This achieves optimum sound decoupling.



Fig. 7-17 Fully installed sound-dampening bracket.

i Note: Failure to install correctly may compromise acoustic performance

7.3.2.2 Bracketing plan for vertical stack

A plan for effective bracketing of a sound-insulating vertical stack with RAUPIANO PLUS is displayed graphically (see Fig. 7-18). If a wall is not available for fixing it is acceptable to fabricate a support wall or floor/ceiling brackets to enable attachment of vertical pipe brackets providing the bracketing configuration is followed as per section 7.5.1 and 7.5.2. Most importantly brackets on vertical stack work attached to a wall or support bracket must always be loose on the pipe as per the Sound Dampening Double Bracket and Guiding Bracket to ensure acoustic performance is optimised.

1. Install stack pipe from bottom to top.
2. Install one sound-dampening bracket per floor per stack within the top quarter of the stack (ie. below the branch).
3. Install one guiding bracket per floor per stack within the bottom quarter of the stack (ie. 0.5 to 1 metres above floor level).
4. If the distance between the sound-dampening bracket and the guiding bracket in that floor is longer than 2 metres (ie. floor height greater than 4 metres), install additional guiding bracket(s) every 2 metres.
5. At every 3rd floor, install a security bracket directly under the sound dampening bracket (for single dwellings only on the first storey) to prevent the vertical stack from sliding apart.



- Although it is a good practice to install the sound-dampening bracket directly below the pipe socket, it is not necessary to do so as long as it is not installed on the socket itself.

- The guiding bracket permits free longitudinal movement of RAUPIANO PLUS pipe.
- For non acoustic installations, the sound dampening bracket can be replaced with a fixing/ security bracket.

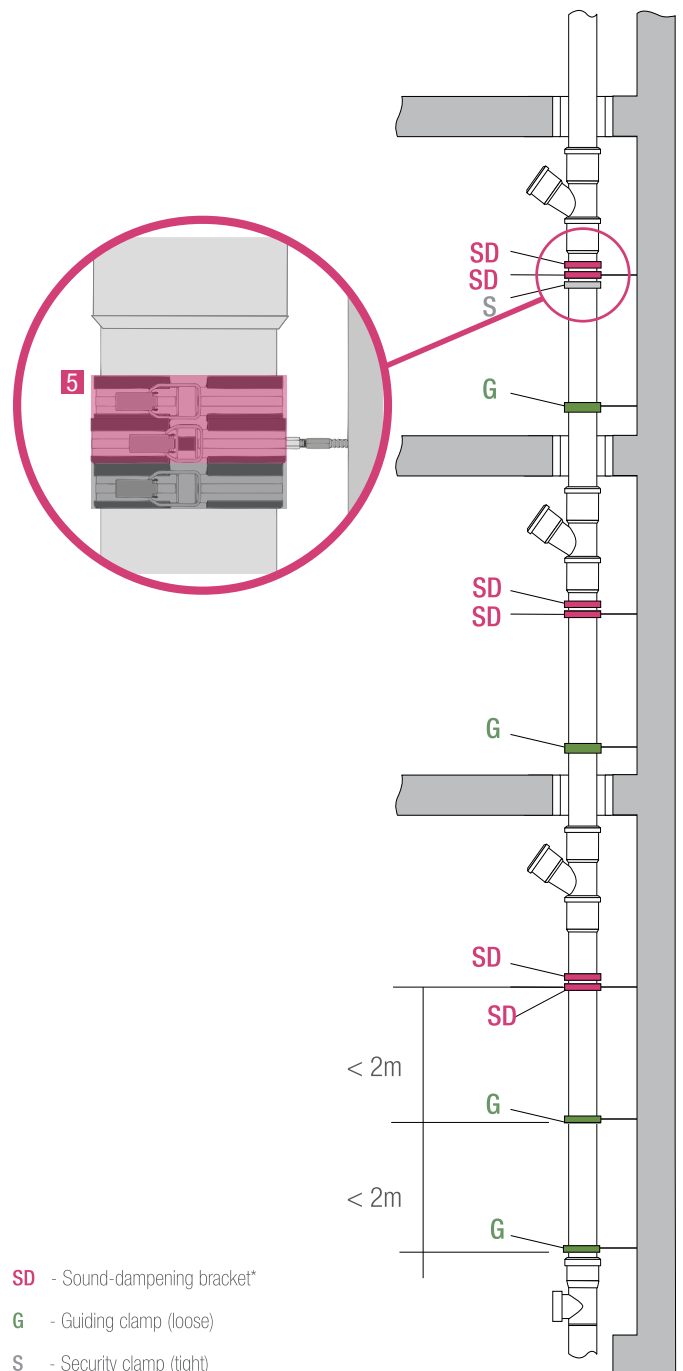

- SD - Sound-dampening bracket*
- G - Guiding clamp (loose)
- S - Security clamp (tight)
- F - Fixing clamp (tight)

* Magenta colour for illustration purposes only. Bracket colour is black.

Fig 7-18 Bracketing plan for vertical stack

7.4 Floor waste gully installation

RAUPIANO PLUS Floor waste gully includes:

- 3-way riser (DN 110 floor inlet, 3 x DN50 inlets, DN75 outlet).
- Removable insert that creates a water sealing column for the "trap".
- The same push-fit joining method applies for all the inlets and outlet.

1. Drill hole for required inlets using 44 mm hole saw. Prior to drilling out inlets, remove the baffle to prevent damaging the baffle. Ensure this is replaced and pushed the entire depth of the baffle housing.

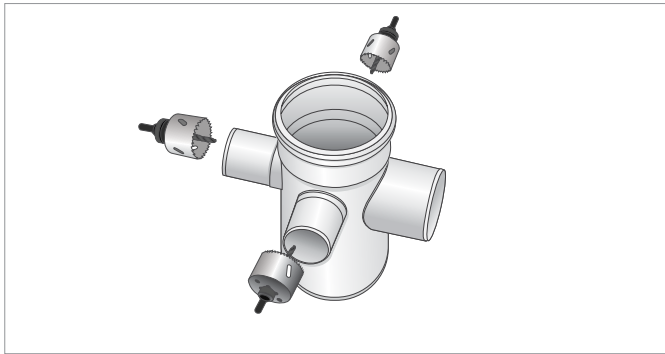

Fig. 7-19 Floor waste gully

2. Assemble double socket over DN50 inlets

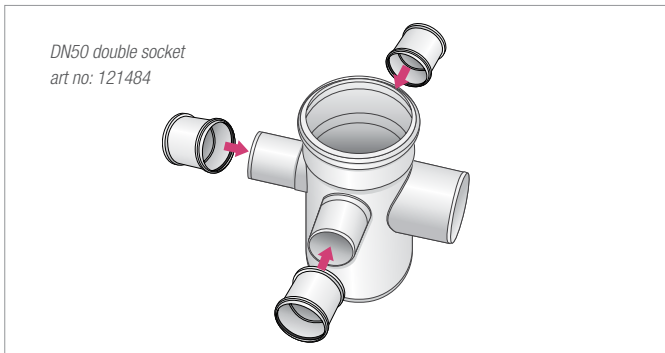

Fig. 7-20 Floor waste gully with double sockets on inlets



Fig. 7-21 Removing the Baffle

Note: Check and ensure that the baffle is firmly pushed down to the bottom after installation

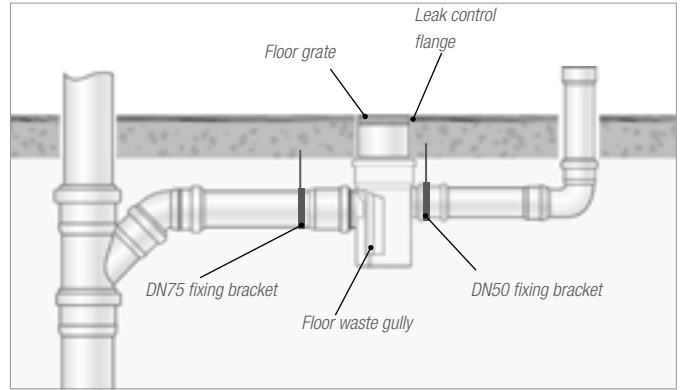

Fig. 7-22 Bracketing of floor Waste Gully (General example only)

3. Install floor waste gully beneath slab by inserting over DN110 penetration DN110 riser pipe must be chamfered and have no internal burr.
4. Install socket of DN75 pipe over outlet
5. Install DN50 waste pipe into socket of inlets
6. Secure floor gully by installing fixed brackets on DN75 outlet and opposite DN50 inlet (Attempt to bracket as close as possible to the FWG).
7. Recommended to use a leak control flange with rubber fins

7.5 P-trap siphon / 110mm disconnecter gully

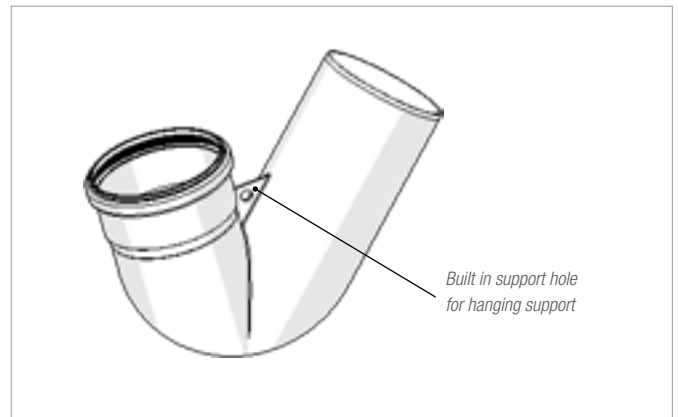

Fig. 7-23 RAUPIANO PLUS P-trap siphon

RAUPIANO PLUS P-trap siphon provides 50 mm water seal to prevent foul odour from coming out of the drainage lines. The P-trap siphon is to be used together with DN 110 bend 45°.

When installing this P-trap, it is important to install the pipe support properly to ensure safe operation of the drainage system.

7.6 Cleaning the waste pipe system



Fig. 7-24 RAUPIANO PLUS I.O. access pipe.

Installing access pipes enables mechanical cleaning of the waste pipe system.

- RAUPIANO PLUS I.O access pipe is supplied with an insert to make the opening surface flush with the pipe inner diameter.
- The access cap has a threaded connection.
- The installation locations of inspection opening shall adhere to AS/NZS 3500.2.
- IO access pipe cannot be used to rise to surface.
- If this is required, use a DN110/87 deg junction art #1450921



Do not use sharp cleaning devices for mechanical cleaning. Pressure drainage equipment is recommended. The use of Momar cleaning chemicals should not be used on rubber ring drainage systems

7.7 Socket plug



Fig. 7-25 RAUPIANO PLUS socket plug.



Fig. 7-26 RAUPIANO PLUS securing clip.

The socket plug can be used to plug-off the pipe ends if they are not in use. The socket plug is to be used together with the securing clip to ensure a safe and tight jointing. The securing clip is manufactured from galvanised steel.

7.8 Installing pipes in masonry



Observe the applicable national regulations for recesses and slots in the masonry.

- Make wall chases and penetrations in such a way that the pipeline can be laid without tension.
- Avoid sound bridges between the masonry and the pipe.

If the pipes will be plastered directly without using a plaster board:

- Fully wrap pipes and fittings with flexible material such as a closed cell, non-absorbent lagging to prevent sound bridges between pipe and plaster/masonry.
- In locations where temperatures above 90°C may be reached due to external heat sources, protect pipes and fittings with appropriate measures to avoid excessive heat.

7.9 Installing pipes in concrete

RAUPIANO PLUS pipes and fittings have WaterMark certifications to AS/NZS 7671:2010 and AS/NZS 5065:2005 (WM 70060 and WM 71503 respectively) and are approved for installation within the concrete slab, pending approval of the structural engineer. During the project design phase, consult with your structural engineer on the required slab thickness and cover thickness for the appropriate loading of the slab.

Due to the nature of the installation, there will be direct contact between the pipelines and the concrete, creating sound bridges along the pipelines. If certain acoustic performance is desired, it is recommended to insulate the complete buried pipeline sections to minimize sound-bridging, e.g. by using flexible PE-foam strip.

If there are no acoustic requirements, the pipe and fittings can be concealed directly in the concrete with only the joints to be taped to prevent any concrete from penetrating the push-fit joint.

The following steps need to be taken:

- The pipes are to be appropriately fixed to prevent any movement during concrete pouring
- If there is an acoustic requirement and that lagging is required, pipes longer than 500mm shall be inserted into the socket fully and then pulled out 10mm to ensure that expansion of the pipe is accounted for.
- If there is no acoustic requirement, pipes shall be inserted fully into the socket.
- Fittings shall always be inserted fully into the socket.
- All joints that are going to be concealed inside the concrete shall be taped to prevent any concrete from penetrating the push-fit joint
- Seal off any pipe openings with socket plugs and conduct hydrostatic test prior to concrete pouring.
- Leave the water inside the pipeline during and at least 24 hours after the concrete pour for the following reasons:
 - To enhance the strength of the pipe structure against the force from concrete pour
 - To enable easy visual checking for any leakage within the concealed pipeline



CAUTION

Danger of damage to property!

Damage to the pipelines!

- Avoid placing the weight of the concrete on the pipelines by making provisions for dissipating the load, e.g. by using:
 - Spacers in the case of reinforcing steels
 - Carrying boxes
 - Brackets
- Avoid walking on the pipes during concrete application.

7.10 Ceiling penetrations

Ceiling penetrations must be constructed to be moisture-proof and sound-insulating as per BCA requirements. Fire-protection measurements are necessary if pipes penetrate through fire-rated building elements. Refer to chapter 5 for details.

If mastic asphalt is to be applied to the floor: Protect exposed pipeline components with ceiling liner, protective sleeves or by wrapping them with heat-insulating materials.

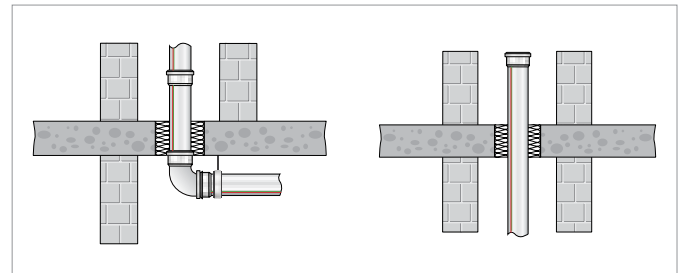

Fig. 7-27 Typical ceiling penetration through non-fire rated building elements (General example only)

7.11 Installation as stormwater piping

There is a risk of condensation on pipes installed as stormwater piping within the building.

Condensation appears when the temperature of the pipe walls drops below the dew point temperature of the ambient air due to cold rain water, for example. Humidity from the ambient air then condenses on the pipe surface.

It is recommended to wrap all pipework where condensation could occur with closed-cell insulation materials.



RAUPIANO acoustic data is not applicable for Stormwater application.

Fixing of stormwater piping

To prevent the pipelines from sliding apart, a security bracket is to be attached to the pipe directly below the sound-dampening bracket. (one per stack, one per stack, every third floor).

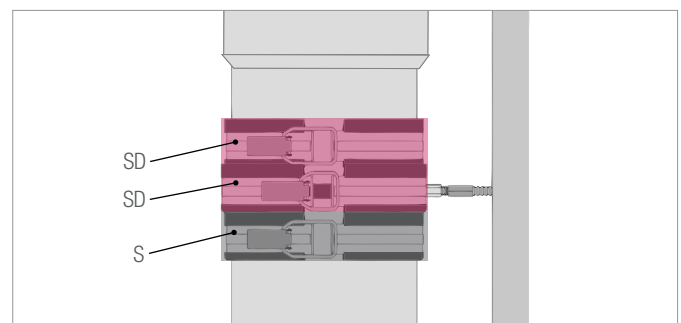

Fig. 7-28 Fixing of stormwater piping

- SD** Sound-dampening bracket
- S** Security bracket (tight, not fixed to wall)

7.12 RAUPIANO Push-Fit Lock

The RAUPIANO Push-Fit Lock increases the socket joint integrity by preventing the pipe from being pulled-out of the socket at higher load.

Push-Fit Lock Application

1. Stormwater Downpipe installed inside buildings up to a maximum pressure of 2 bar (20 m).
2. Connection of Pump stations up to a maximum pressure of 2 bar
3. As an alternative solution, the Push-Fit Lock can be used to secure the socket plug, it would be used in replacement of using a securing clip.



Fig. 7-29 Push-Fit Lock assembled on a socket

For Pump station application, it is recommended to install the Push-Fit Lock around all sockets in horizontal and vertical pipework where the applied pump pressure may exceed 1 bar.

In stormwater and drainage applications it is recommended to install the Push-Fit Lock around all sockets in horizontal and vertical pipework in buildings of more than 10m in height.

In addition, the Push-Fit Lock can also be used to prevent the pipe from sliding apart during installation phase.

It is easily installed and dismantled. The auto-locking assembly mechanism prevents it from falling off the pipe, even when the Push-Fit Lock has not been tightened yet.

Installation is simple, fast and secure. The necessary bolts and nuts are supplied together with the Push-Fit Lock.

RAUPIANO PLUS

Installation below ground

RAUPIANO PLUS is suitable for installations both above and below ground, inside and outside the building structure. The installation is to be carried out in accordance with the static requirements.*

Other applicable standards/test certificates

The following standards are to be observed when installing RAUPIANO PLUS:

- National Construction Code
- New Zealand Building Code
- AS/NZS 5065
- AS/NZS 3500
- AS/NZS 2566.2

8.1 General

Generally applicable pipeline construction rules are to be followed. Careful and professional handling of the pipes and fittings during transport, storage and laying must be ensured. Only plumbers who carry a recognised plumbing certificate for Australia or New Zealand should be installing the pipework

§

Observe the following:

- Accident prevention regulations of the employers' liability insurance
- Road traffic regulations
- Any special project-dependent regulations
- Applicable requirements contained in the regulations or technical regulations

8.2 Pipe trench

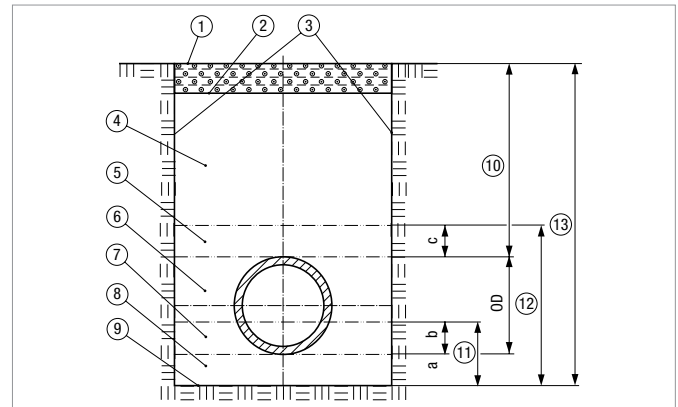

Fig. 8-1 Schematic structure of pipe trenches

- | | |
|--|--|
| 1 Surface | 10 Covering height |
| 2 Bottom edge of street or sliding construction (if present) | 11 Thick bedding |
| 3 Trench walls | 12 Thick embedment |
| 4 Main filling | 13 Trench depth |
| 5 Cover | a Thick lower intermediate bedding layer |
| 6 Side filling | b Thick top bedding layer |
| 7 Top bedding layer | c Thick cover |
| 8 Bottom bedding layer | OD Outer diameter pipe |
| 9 Trench bottom | |

Pipe trenches must comply with AS/NZS 3500.2 and AS/NZS 2566.2.

NOTE:

- Ensure the structural integrity of the trench either via suitable shoring (joists) or other suitable measures.
- Prepare trench bottom according to the required gradient.
- Make suitable recesses in the bottom pipe bed layer at the pipe connection points or in the trench bottom so that the entire length of the pipe makes contact.
- Ensure a consistently level lie of the pipelines.
- Protect trench bottom from the effects of frost.
- In high altitude and cold climates, do not use snow, ice or frozen soil above or below the pipelines.
- Remove trench shoring materials according to the static calculations so that the pipeline is neither damaged nor repositioned.

* Static calculations must be conducted in order to quantify that mechanical loading on the RAUPIANO PLUS pipe will be avoided at all times. Drains constructed with less than minimum cover shall comply with Clause 3.7 of AS/NZS 3500.2.

8.3 Embedment

The embedment of the pipe installed in ground is comprised of the:

- Pipe bedding
- Side support
- Pipe overlay
- Backfill



Ensure that the embedment is created carefully, as it is the main determining factor in the supportive capacity of the pipe.

Bedding, sidefilling and initial backfilling shall be carried out in accordance with the design and specification. The embedment should be protected against any foreseeable change of its load bearing capacity, stability or position that could be caused by removal of sheeting, groundwater influences or other excavation work. When parts of a pipeline need anchoring or strengthening, this shall be done before placement of the embedment. During placement of the embedment special attention should be given to the following:

- avoidance of displacement of the pipeline from line and level;
- care for placement of upper bedding to ensure that the voids under the pipe are filled with compacted material.

8.3.1 Bedding Materials

Embedment materials must comply with the design specifications. This can also be the excavated soil, whose suitability has been checked.

When selecting embedment materials and their grain size, observe the following:

- Pipe diameter
- Pipe material
- Pipe wall thickness
- Soil characteristics

Embedment materials must comply with requirements stated in AS/NZS 3500.2 - Clause 5.4 and AS/NZS 2566.2.

8.3.2 Pipe bedding

The pipe bedding is comprised of a bottom bedding layer, a pipe side support layer and a top bedding layer. The width of the pipe bedding must match the trench width.

AS/NZS 3500.2 - Section 5.4 Bedding of Drains and Backfilling must be complied to. The following are the manufacturers recommendations for RAUPIANO PLUS pipes installed below ground.

Location	Minimum depth of cover (mm)
Subject to heavy vehicular traffic	N/A
Subject to light vehicular traffic	500*
Elsewhere	300*

Table 8-1 Minimum depth of cover for RAUPIANO PLUS

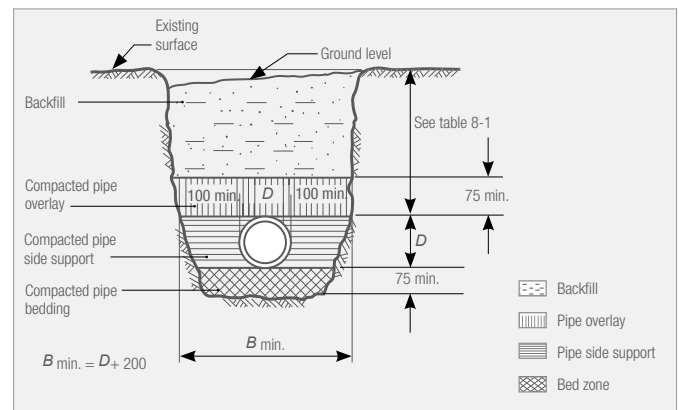

Fig. 8-2 Recommended bedding of drains

Special pipe bedding or support construction type

Any localized quantity of soft ground below trench bottom shall be removed and replaced with suitable bedding material. If more extensive quantities are encountered a re-evaluation of the structural design should be undertaken.

NOTE:

Very soft or expansive clays, irregular or fragmented rock, and saturated soils, are unsuitable pipe beddings and should be avoided. Where avoidance is impracticable, most of these situations may usually be overcome by adequate drainage of ground water, and removing the unsuitable material and replacing it with compacted embedment material.

* Static calculations must be conducted in order to quantify that mechanical loading on the RAUPIANO PLUS pipe will be avoided at all times. Drains constructed with less than minimum cover will be required to fulfill Clause 3.7 of AS/NZS 3500.2.

8.3.3 Filling

To prevent surface settling, side and main filling are to be put in place in accordance with the design requirements.

8.3.4 Compacting

The degree of compacting must correspond to the requirements for the pipeline according to the static calculation. The degree of backfilling must comply with AS/NZS 3500.2 - Section 5.5



- If necessary, compacting of the cover must be carried out by hand directly over the pipe.

- Mechanical compacting of the main filling cannot be carried out until a layer that is at least 30 cm thick is in place over the pipe apex.
- Selection of the compacting equipment, the number of compacting runs and the layer thickness to be compacted must be appropriate for to the material to be compacted and the pipeline.
- Compacting the main or side filling via silting is only permissible in exceptional cases with suitable cohesionless ground.

8.4 Connections to pipes and manholes

Connections to pipes and manholes shall be made by using prefabricated elements. Compatible junctions, connection fittings or saddle fittings may be used. The connection shall be made in accordance with the installation instructions of the manufacturer of the prefabricated elements, and shall be leaktight.

8.5 Expansion joints in ground

For pipes installed in ground it is not required to pull the pipe end out by 10mm to provide an expansion joint, refer to chapter 7.2.

RAUPIANO PLUS

Adaptation to drainage systems

8.

If it is necessary to adapt to PVC systems which are manufactured according to AS/NZS 1260, the simple adaptor from RAUPIANO PLUS to PVC system is available. To install these adaptors, please adhere the following steps:

- apply primer and solvent cement to the PVC side of the adaptor
- insert the solvent-cemented portion into a female socket of PVC fitting
- apply REHAU lubricant to the other portion of the adaptor and insert into RAUPIANO PLUS socket

These adaptors are made of PVC and available for the following sizes:

PVC adaptor	From		To	
	RAUPIANO PLUS	OD (mm)	PVC system	OD (mm)
DN 40/40	DN 40	40	DN 40	43
DN 50/40	DN 50	50	DN 40	43
DN 50/50	DN 50	50	DN 50	56
DN 75/50	DN 75	75	DN 50	56
DN 75/65	DN 75	75	DN 65	69

Table 9-1 Available adaptor sizes from RAUPIANO PLUS to PVC system
 * For RAUPIANO sizes DN 110 and DN 160 a PVC adaptor is not required as they have the same OD as PVC.

	DN 40	DN 50	DN 65	DN 100, DN 150
PVC adaptor	<p>DN 40 PVC fitting (female socket)</p> <p>DN 40/40 PVC adaptor (Art. No. 123009) (REECE code 1450706)</p> <p>DN 40 RAUPIANO PLUS pipe or fitting</p>	<p>DN 50 PVC fitting (female socket)</p> <p>DN 50/50 PVC adaptor (Art. No. 123012) (REECE code 1450707)</p> <p>DN 50 RAUPIANO PLUS pipe or fitting</p>	<p>DN 65 PVC fitting (female socket)</p> <p>DN 65/75 PVC adaptor (Art. No. 123016) (REECE code 1450708)</p> <p>DN 75 RAUPIANO PLUS pipe or fitting</p>	<p>DN 100 / DN 150</p> <p>DN 110 / DN 160 RAUPIANO PLUS pipe or fitting</p>
	<p>DN 40 PVC fitting (male spigot)</p> <p>DN 50/40 PVC adaptor (Art. No. 103525) (Reece code 1451089)</p> <p>DN 50 RAUPIANO PLUS pipe and/or fitting socket end</p>	<p>DN 50 PVC fitting (male spigot)</p> <p>DN 75/50 PVC adaptor (Art. No. 103526) (Reece code 1451090)</p> <p>DN 75 RAUPIANO PLUS pipe and/or fitting socket end</p>		

Table 9-2

9.2 Drainage fittings to RAUPIANO PLUS

There are several options for connecting plumbing fixture drainage fittings or other pipe materials to RAUPIANO PLUS drainage pipes or fittings:

- RAUPIANO PLUS connection pipe
- RAUPIANO PLUS connection bend
- RAUPIANO PLUS fitting with rubber nipple

RAUPIANO PLUS connection pipe

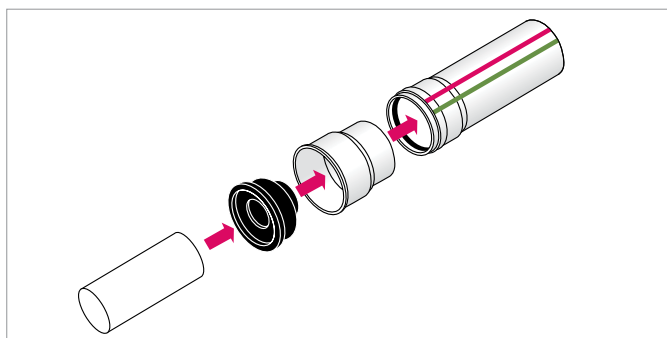

Fig. 9-1 RAUPIANO PLUS connection pipe with rubber nipple.

1. Insert rubber nipple in the socket of the connection pipe.
2. Apply REHAU lubricant on the sealing lips of the rubber nipple.
3. Insert male end of drain fitting of plumbing fixture into the rubber nipple.

	DN 40	DN 50	DN 50
<p>Fixture trap</p>	<p>OD 32 - 40 mm metal pipe</p>	<p>OD 32 - 40 mm metal pipe</p>	<p>OD 47 - 50 mm metal pipe</p>
	<p>DN 50/40 rubber nipple (Art. No. 126253) (REECE code 1450882)</p>	<p>DN 50/40 rubber nipple (Art. No. 126253) (REECE code 1450882)</p>	<p>DN 50/50 rubber nipple (Art. No. 121913) (REECE code 1450883)</p>
	<p>DN 40/40 connection pipe (Art. No. 123164) (REECE code 1450752)</p>	<p>DN 50/40-30 connection pipe (Art. No. 121414) (REECE code 1450753)</p>	<p>DN 50/50 connection pipe (Art. No. 121424) (REECE code 1450754)</p>
	<p>DN 40 RAUPIANO PLUS pipe or fitting</p>	<p>DN 50 RAUPIANO PLUS pipe or fitting</p>	<p>DN 50 RAUPIANO PLUS pipe or fitting</p>

Table 9-3 Drainage fittings to RAUPIANO PLUS adaption

RAUPIANO PLUS fitting with beaded rubber nipple

1. Remove the installed sealing rubber from the pipe or fitting socket.
2. Insert rubber nipple with bead into the fitting socket.
3. Insert male end of the drain fitting of plumbing fixture into the rubber nipple.

For more connection from other pipe system to RAUPIANO PLUS, for example from metal/plastic P- or S-trap.

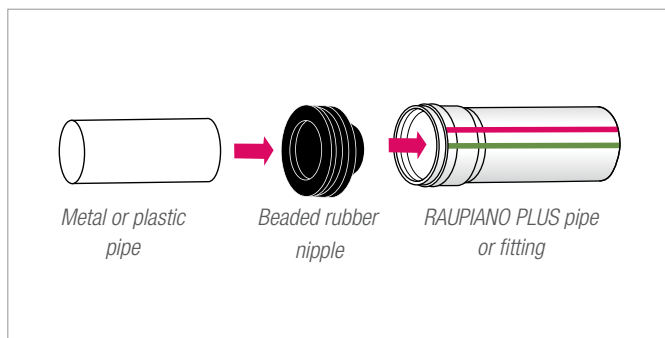

Fig 9-2

	DN 40	DN 50	DN 50
Fixture trap			
	OD 32 mm metal pipe	OD 32 mm metal pipe	OD 40 mm metal pipe
	DN 40/30 rubber nipple with bead (Art. No. 122923) (REECE code 1450884)	DN 50/30 rubber nipple with bead (Art. No. 122933) (REECE code 1450885)	DN 50/40 rubber nipple with bead (Art. No. 122943) (REECE code 1450886)
	DN 40 RAUPIANO PLUS pipe or fitting (without rubber ring)	DN 50 RAUPIANO PLUS pipe or fitting (without rubber ring)	DN 50 RAUPIANO PLUS pipe or fitting (without rubber ring)

Table 9-4 Drainage fittings to RAUPIANO PLUS adaption

9.3 Rubber sleeve adaptor for Cast Iron pipe or other materials



Fig. 9-3 Rubber sleeve for same or different outer diameters.

For transition from RAUPIANO PLUS pipes to Cast Iron pipes or other materials for drainage systems, rubber sleeve adaptors can be used. These rubber sleeves come with rubber seal that is attached to the pipe ends and two stainless-steel worm-gear clamps. These rubber sleeve adaptors can be used in new construction or renovation works.

Below are the properties of the rubber sleeve adaptor.

Material	Rubber
Tightening device	Stainless-steel worm-gear clamps
Recommended tightening torque	3 Nm (Newton metres)
Pressure resistance	1 bar
Chemical resistance	pH 2 - 12

Table 9-5 Properties of rubber sleeve adaptor.

Installation steps:

1. Insert RAUPIANO PLUS pipe end into one end of the rubber sleeve adaptor.
2. Insert Cast Iron / other material pipe end into the other end of the rubber sleeve adaptor.
3. Tighten the worm-gear clamps on both ends of the rubber sleeve adaptor without exceeding the maximum tightening torque.

The rubber sleeve adaptor can be installed on most Cast Iron and other materials pipe sizes, the table below specifies the suitable dimensions of Cast Iron or other pipe materials.

























From metal or other plastic pipe					
	OD 40 mm pipe (plastic/metal)	OD 53 - 63 mm pipe (plastic/metal)	OD 75 - 89 mm pipe (plastic/metal)	OD 100 - 115 mm pipe (plastic/metal)	OD 40-56mm metal pipe
					
					
	*DN 50/40 rubber adaptor (REECE code 1430720)	DN 50/53-63 rubber sleeve adaptor (Art. No. 125024) (REECE code 1450894)	DN 75/75-89 rubber sleeve adaptor (Art. No. 125034) (REECE code 1450895)	DN 110/110 rubber sleeve adaptor (Art. No. 123914) (REECE code 1450897)	*Reducing adaptor 40-56mm (REECE code 1430938)
					
					
DN 50 RAUPIANO PLUS pipe (plain)	DN 50 RAUPIANO PLUS pipe (plain)	DN 75 RAUPIANO PLUS pipe (plain)	DN 110 RAUPIANO PLUS pipe (plain)	DN 110 RAUPIANO PLUS pipe plain	

Table 9-6 Metal and other pipe to RAUPIANO PLUS adaption

* Fits inside pipe

RAUPIANO PLUS

Leak test

10.

§

The leak test must be carried out in accordance with AS/NZS 3500.2

For pipes installed below ground, testing shall be conducted prior to the placement of the trench fill (backfill).

10.1 Hydrostatic test

Where there are water restrictions or the network provider has a water management strategy, hydrostatic testing may not be permitted, in which case an air or vacuum seal test must be conducted. In accordance with section 13 of AS/NZS 3500.2

The sanitary plumbing and sanitary drainage shall be filled with water -

- (a) in the case of sanitary drainage, to a height of not less than 1m above the pipe soffit level at the highest point of the section being tested;
- (b) in the case of sanitary plumbing, to the spill level of the highest fixture or to the flood level of the lowest sanitary fixture, whichever is higher; and
- (c) in the case of pipe installed below ground, to a height not less than 2 m (or 20 kPa) above the pipe soffit level at the highest point of the section being tested or 2 m (or 20 kPa) above ground water table, whichever is the greater.

The pressure shall be maintained without leakage for at least 15 min. The source of any leak shall then be ascertained and any defects repaired. The section under test shall then be retested.

* Various air test pipe bungs are available.

10.2 Air Test

Alternatively, the test can be carried out with air.

The air test is carried out with:

- Test pressure 15 kPa
1. Ensure firm and sealed seating of plugs.
 2. Pressurise the system and stabilize for a minimum of 3 minutes while checking for leaks
 3. After pressure is stabilized commence the test by allowing the pressure to reduce to 10 kPa
 4. Start test time and record drop in pressure during the test time
 5. The section of sanitary plumbing or sanitary drainage being tested shall not have a drop in pressure greater than 3 kPa over the minimum test duration specified in Table 10.1

Pipe size DN	Test Length (m)					
	50	100	150	200	250	300
	Minimum test duration, min					
110	2	2	2	2	3	3
160	3	3	3	6	6	6

Table 10-1 Minimum test duration for Air Test in minutes

* Ensure all open ends are secured to prevent pipe caps from blowing off during air test.

RAUPIANO PLUS

Certifications and test reports



Australia



New Zealand



RAUPIANO PLUS and other REHAU product Watermark Certificates are available for download from www.rehau.com.au/raupiano Please be advised that the REHAU PVC Adaptors have Best Environmental Practice Certification and the certificate is available for download from the above link.

RAUPIANO PLUS

Technical specifications

12.

Material	PP-MD mineral-reinforced (pipes and fittings)	
Size range	DN 40 – DN 160	
Area of application	Waste water pipes in buildings and laid below ground inside and outside the building structure	
Chemical resistance	Polypropylene basis No waste water containing benzene Seals made of SBR	in accordance with DIN 8078 DIN 4060, DIN EN 681-1
Application	Waste water with ph value 2 – 12 Waste water temperature up to 95°C (brief periods) or 90°C (continuous load) Maximum head pressure 1 bar (10m) respectively 2 bar (20m) when using Push-fit Lock. Design Service Life 50 years within these application parameters.	
Product warranty	10 years	
Density of pipes	1.9 g/cm ³	
Coefficient of thermal expansion	0.09 mm/m-K	DIN 53752
Ring stiffness	> 4 kN/m ²	DIN EN ISO 9969
Tensile strength	> 16 N/mm ²	DIN EN ISO 527-3
Elongation before breaking	Approx. 150 %	DIN EN ISO 527-3
Modulus of elasticity	Approx. 2,700 N/mm ²	DIN EN ISO 527-2
MFR 190/5	Approx. 1.7 g/10 min.	DIN EN ISO 1133
MFR 230/2,16	Approx. 0,82 g/10 min.	DIN EN ISO 1133
Pipe structure	Pipes features innovative three-layer structure - Impact-resistant and shock-proof PP outer layer - Highly rigid middle layer made of mineral-reinforced PP - Abrasion-resistant with smooth internal wall Fittings - Mass optimisation in redirection area for increased sound insulation DN 110 – DN 160	
Halogen contents	Halogen-free (no F, Cl, Br, I)	
Connection	Push-fit socket with factory-installed lip sealing ring	
Fire behaviour	B2 (normally inflammable) D,S3-d0	In accordance with DIN 4102 In accordance with EN 13501-1
System compatibility	Adapters to PVC system and other pipe materials are available	
Standards and approval	System test according to: - AS/NZS 7671, WM70060 - AS2887, WM71501 - AS/NZS 1260, WM71502 - AS/NZS 5065, WM71503 System assessed according to: - BRANZ Appraisal No. 809 - Best Environmental Practice PVC to AS/NZS 1260	
Sound insulation	Tested to ISO 140 methodology. Sound insulation performance rated according to ISO 717. Fulfills BCA/NCC requirement of Rw + Ctr 40 for habitable rooms without acoustic lagging.	
Independent monitoring	Süddeutsches Kunststoffzentrum (SKZ), Germany	
Fire load	The RAUPIANO PLUS fire load was determined by MPA. It is - 14,992 kJ/kg Transferred to a DN 110 RAUPIANO PLUS pipe: - 7.9 kWh/m - 28,464.8 kJ/m	

Tab. 11-1 Technical specifications.

RAUPIANO PLUS

Chemical resistance

13.

Pipe and fitting

The specifications below are used as a general guidance as to the chemical resistance of the material and cannot simply be applied to all applications. They shall not be used as a guidance to determine the possible affects on the reagent. Mechanical behaviour can be impaired in cases where tension and the presence of chemicals occur simultaneously (tension-fracture corrosion).

Rubber sealing ring

The types of rubber used generally exhibit high chemical resistance, but components of esters, ketones and aromatic and chlorinated hydrocarbons in sewer water can lead to swelling of the material, which can influence the tightness of the connection.

If in doubt, we recommend testing the suitability of the pipe, fitting and seal material in existing systems or have them checked in a laboratory. Contact REHAU if necessary.

Table legend

- r = resistant
- cr = conditionally resistant
- nr = not resistant
- = not tested

Reagent	Concentr. %	Temp. °C	RAUPP
2-Propen-1-ol	96	20	r
	96	60	r
Acetaldehyde + acetic acid	90/10	20	–
Acetaldehyde, aqueous	40	40	r
Acetaldehyde, concentrated	100	20	–
Acetate ether	100	20	–
Acetic acid, aqueous	up to 25	40	r
	up to 25	60	r
	25–60	60	r
	80	40	r
Acetic acid, concentrated	95	40	–
Acetic anhydride	100	20	r
	100	40	cr
	100	60	cr
Acetone	100	20	r
	100	60	r
Acetone, aqueous	traces	20	r
Acronal dispersions	com. avail.	20	–
Acronal solutions	com. avail.	20	–
Acrylic acid ethyl ester	100	20	–
Adipic acid, aqueous	saturated	20	r
	saturated	60	–
Aluminium chloride	diluted	40	r
	diluted	60	r
	saturated	60	r

Reagent	Concentr. %	Temp. °C	RAUPP
Aluminium sulfate, aqueous	diluted	40	r
	diluted	60	r
	saturated	60	r
Alums, aqueous	diluted	40	r
	diluted	60	r
	saturated	60	r
Ammonia, gas	100	60	r
Ammonia, liquid	100	20	r
Ammonium chloride, aqueous	diluted	40	r
	diluted	60	r
	saturated	60	r
Ammonium fluoride, aqueous	up to 20	20	r
	up to 20	60	r
Ammonium hydroxide	warm sat.	40	r
	warm sat.	60	r
Ammonium nitrate, aqueous	diluted	40	r
	diluted	60	r
	saturated	60	r
Ammonium sulfate, aqueous	diluted	40	r
	diluted	60	r
	saturated	60	r
Ammonium sulfide, aqueous	diluted	40	r
	diluted	60	r
	saturated	60	r
Aniline hydrochloride, aqueous	saturated	20	r
	saturated	60	r

Reagent	Concentr. %	Temp. °C	RAUPP
Aniline, aqueous	saturated	20	r
	saturated	60	r
Aniline, pure	100	20	r
	100	60	r
Animal glue	custom. conc.	20	r
	custom. conc.	60	r
Anthraquinonesulfonic acid, aqueous	suspension	30	r
Antiformin, aqueous	2	20	–
Antimony chloride, aqueous	90	20	r
Arsenic acid, aqueous	diluted	40	r
	diluted	60	r
	80	40	r
	80	60	r
Beef tallow emulsion, sulphonated	com. avail.	20	–
Beer	com. avail.	20	r
Beer colouring agent	com. avail.	60	r
Benzaldehyde, aqueous	0,1	60	–
Benzene	100	20	cr
Benzoic acid, aqueous	any	20	r
	any	40	r
	any	60	r
Bisulphite solution, w/ SO ₂	warm sat.	50	r
Bleaching liquor, containing 12.5 % active chlorine	usage conc.	40	–
	usage conc.	60	cr
Borax, aqueous	diluted	40	r
	diluted	60	r
	saturated	60	r
Boric acid, aqueous	diluted	40	r
	diluted	60	r
	saturated	60	r
Brandy	com. avail.	20	r
Bromine fumes	minimal	20	nr
Bromine, liquid	100	20	nr
Butadiene	100	60	–
Butane, gaseous	50	20	r
Butanediol	up to 100	20	–
Butanediol, aqueous	up to 10	20	r
	up to 10	40	r
	up to 10	60	r
Butanol	up to 100	20	r
	up to 100	40	r
	up to 100	60	cr
Butyl acetate	100	20	cr

Reagent	Concentr. %	Temp. °C	RAUPP
Butylene, liquid	100	20	–
Butylphenol	100	20	r
Butynediol	up to 100	40	–
Butyric acid, aqueous	20	20	r
	concentr.	20	r
Calcium chloride, aqueous	diluted	40	r
	diluted	60	r
	saturated	60	r
Calcium nitrate, aqueous	50	40	r
Carbolineum, aqueous	usage conc.	20	–
Carbon dioxide, aqueous under 8 atmospheric pressures	saturated	20	–
Carbon dioxide, dry	100	60	r
Carbon dioxide, moist	any	40	r
	any	60	r
Carbon disulfide	100	20	cr
Carbon tetrachloride, technical	100	20	nr
Caustic potash solution, aqueous	up to 40	40	r
	up to 40	60	r
	50/60	60	r
Caustic soda, aqueous	up to 40	40	r
	up to 40	60	r
	50/60	60	r
Chloramine, aqueous	diluted	20	–
Chloric acid, aqueous	1	40	–
	1	60	–
	10	40	–
	10	60	–
	20	40	–
Chlorine water	20	60	–
	saturated	20	cr
Chlorine, gaseous, dry	100	20	nr
Chlorine, gaseous, moist	0,5	20	nr
	1	20	nr
	5	20	nr
Chlormethyl	100	20	–
Chloroacetic acid (mono)	100	40	r
	100	60	–
Chloroacetic acid (mono) aqueous	85	20	r
Chlorosulfonic acid	100	20	nr
Chromic acid, aqueous	up to 50	40	–
	up to 50	60	cr

Reagent	Concentr. %	Temp. °C	RAUPP
Chromic acid/Sulphuric acid/Water	50/15/35	40	nr
	50/15/35	60	nr
Cider	com. avail.	20	r
Citric acid, aqueous	up to 10	40	r
	up to 10	60	r
	saturated	60	r
Clophene	com. avail.	20	-
	com. avail.	60	-
Coconut fat alcohol	100	20	r
	100	60	cr
Copper fluoride, aqueous	2	50	r
Copper sulfate, aqueous	diluted	40	r
	diluted	60	r
	saturated	60	r
Cresol, aqueous	up to 90	45	-
Crotonaldehyde	100	20	r
Cyclohexanol	100	20	r
Cyclohexanone	100	20	r
Cyclohexanone	100	20	r
Densodrin W	com. avail.	60	-
Dextrin, aqueous	saturated	20	r
	18	60	r
Diethylether	100	20	cr
Diglycol acid, aqueous	30	60	r
	saturated	20	r
Dimethyl sulfate, aqueous	up to 50	20	r
	up to 50	40	r
	100	40	-
	100	60	-
Dimethylamine, liquid	100	30	-
Disulfuric acid	10	20	nr
Ethanol (fermentation mash)	common	40	r
	common	60	-
Ethanol, aqueous	any	20	r
	96	60	r
Ethanol, denatured (with 2 % toluene)	96	20	cr
Ethanol+ acetic acid (fermentation mash)	common	20	r
Ethyl acetate	100	20	cr
	100	60	nr
Ethylene chloride	100	20	nr

Reagent	Concentr. %	Temp. °C	RAUPP
Ethylene oxide, liquid	100	20	-
Exhaust gas, w/ H ₂ CO ₃	any	60	r
Exhaust gas, w/ HF	traces	60	r
Exhaust gas, w/ NOX	traces	60	r
	higher	60	-
Exhaust gases, w/ H ₂ S ₂ O ₇	lower	20	-
	higher	20	nr
Exhaust gases, w/ H ₂ SO ₄ , moist	any	60	r
Exhaust gases, w/ HCl	any	60	r
Exhaust gases, w/ SO ₂	lower	60	r
	50	50	-
Fatty acids	100	60	cr
Ferric chloride, aqueous	up to 10	40	r
	up to 10	60	r
	saturated	60	r
Fertilizer salts, aqueous	up to 10	40	r
	up to 10	60	r
	saturated	60	r
Fluorsilicic acid, aqueous	up to 32	60	-
Formaldehyde, aqueous	diluted	40	r
	diluted	60	r
	40	30	r
Formic acid	100	20	r
	100	60	cr
Formic acid, aqueous	up to 50	40	r
	50	60	r
Frigen	100	20	cr
Fruit pulp	custom. conc.	20	r
Glucose, aqueous	saturated	20	r
	saturated	60	r
Glycerine, aqueous	any	60	r
Glycine, aqueous	10	40	r
Glycol, aqueous	com. avail.	60	r
Glycolic acid, aqueous	37	20	r
Hexantriol	com. avail.	60	r
Hydrobromic acid, aqueous	up to 10	40	r
	up to 10	60	r
	48	60	r
Hydrochloric acid, aqueous	up to 30	40	r
	up to 30	60	r
	over 30	20	r
	over 30	60	r

Reagent	Concentr. %	Temp. °C	RAUPP
Hydrofluoric acid, aqueous	up to 40	20	r
	40	60	r
	60	20	r
	70	20	r
Hydrogen	100	60	r
Hydrogen peroxide, aqueous	up to 30	20	r
	up to 20	50	r
Hydrogen phosphide	100	20	–
Hydrogen sulfide, dry	100	60	r
Hydrogen sulfide, aqueous	warm sat.	40	r
	warm sat.	60	r
Hydrosulfite, aqueous	up to 10	40	r
	up to 10	60	r
Hydroxylamine sulfate, aqueous	up to 12	35	r
Lactic acid, aqueous	up to 10	40	r
	up to 10	60	r
	90	60	r
Lead acetate, aqueous	warm sat.	50	r
	diluted	40	r
	diluted	60	r
	saturated	60	r
Lead tetraethyl	100	20	r
Magnesium chloride, aqueous	diluted	40	r
	diluted	60	r
	saturated	60	r
Magnesium sulfate, aqueous	diluted	40	r
	diluted	60	r
	saturated	60	r
Maleic acid, aqueous	saturated	40	r
	saturated	60	r
	35	40	r
Malic acid, aqueous	1	20	r
Mersol D	custom. conc.	40	–
Methanol	100	40	r
	100	60	r
Methyl amine	32	20	r
Methylene chloride	100	20	nr
Milk	com. avail.	20	r

Reagent	Concentr. %	Temp. °C	RAUPP
Mixed acid (Sulfuric acid/Nitric acid/Water)	48/49/3	20	nr
	48/49/3	40	nr
	50/50/0	20	nr
	50/50/0	40	nr
	10/20/70	50	cr
	10/87/3	20	nr
Molasses	50/31/19	30	nr
	custom. conc.	20	r
	custom. conc.	60	r
Molasses wort	custom. conc.	60	r
Mowilith D	com. avail.	20	–
Nekal, BX, aqueous	diluted	40	–
	diluted	60	–
Nickel sulfate, aqueous	diluted	40	r
	diluted	60	r
	saturated	60	r
Nicotine compounds, aqueous	usage conc.	20	–
Nicotine, aqueous	usage conc.	20	–
Nitric acid, aqueous	up to 30	50	r
	30/50	50	nr
	98	20	nr
	98	60	nr
Nitrous gasses	concentr.	20	r
	concentr.	60	–
Oils and greases	com. avail.	60	cr
Oleic acid	com. avail.	60	cr
Oleum vapour	lower	20	cr
	higher	20	nr
Oxalic acid, aqueous	diluted	40	r
	diluted	60	r
	saturated	60	r
Oxygen	any	60	–
Ozone	100	20	cr
	10	30	r
Palm kernel oil acid	100	60	–
Paraffin emulsions	com. avail.	20	–
	com. avail.	40	–
Perchloric acid, aqueous	up to 10	40	r
	up to 10	60	r
	saturated	60	–
Petrol	100	60	nr

Reagent	Concentr. %	Temp. °C	RAUPP
Petrol-benzene mixture	80/20	20	cr
Phenol, aqueous	up to 90	45	r
	1	20	–
Phenylhydrazine	100	20	cr
	100	60	–
Phenylhydrazine hydrochloride, aqueous	saturated	20	–
	saturated	60	–
Phosgene, aqueous	100	20	nr
Phosgene, gaseous	100	20	cr
	100	60	cr
Phosphoric acid, aqueous	up to 30	40	r
	up to 30	60	r
	40	60	r
	80	20	r
	80	60	r
Phosphorous pentoxide	100	20	r
Phosphorous trichloride	100	20	r
Photographic developers	com. avail.	40	r
Photographic emulsions	any	40	–
Photographic fixers	com. avail.	40	r
Picric acid, aqueous	1	20	r
Potash, aqueous	saturated	40	–
Potassium borate, aqueous	1	40	r
	1	60	r
Potassium bromate, aqueous	up to 10	40	r
	up to 10	60	r
Potassium bromide, aqueous	diluted	40	r
	diluted	60	r
	saturated	60	r
Potassium chlorate, aqueous	1	40	r
	1	60	r
Potassium chloride, aqueous	diluted	40	r
	diluted	60	r
	saturated	60	r
Potassium chromate, aqueous	40	20	r
Potassium cyanide, aqueous	up to 10	40	r
	up to 10	60	r
	saturated	60	r
Potassium dichromate, aqueous	40	20	r
Potassium ferrocyanide	diluted	40	r
Potassium ferrocyanide, aqueous	diluted	60	r
	saturated	60	r

Reagent	Concentr. %	Temp. °C	RAUPP
Potassium nitrate, aqueous	diluted	40	r
	diluted	60	r
	saturated	60	r
Potassium permanganate, aqueous	up to 6	20	r
	up to 6	40	r
	up to 6	60	r
	up to 18	40	–
Potassium persulfate, aqueous	diluted	40	r
	diluted	60	r
	saturated	40	r
	saturated	60	r
Propane, gaseous	100	20	–
Propane, liquid	100	20	–
Propargyl alcohol, aqueous	7	60	r
Pure acetic acid	100	20	r
	100	40	r
Ramasite	com. avail.	20	–
	com. avail.	40	–
Roaster gases, dry	any	60	r
Seawater	–	40	r
	–	60	r
Silicic acid, aqueous	any	60	r
Silver nitrate, aqueous	up to 8	40	r
	up to 8	60	r
Soap solution, aqueous	concentrated	20	r
	concentrated	60	r
Soda, aqueous	diluted	40	r
	diluted	60	r
	saturated	60	r
Sodium benzoate, aqueous	up to 10	40	r
	up to 10	60	r
	36	60	r
Sodium chlorate, aqueous	up to 10	40	r
	up to 10	60	r
	saturated	60	r
Sodium chlorite, aqueous	50	20	r
	diluted	60	nr
Sodium hydrosulfite, aqueous	diluted	40	r
	diluted	60	r
	saturated	60	r
Sodium hypochlorite, aqueous	diluted	20	r

Reagent	Concentr. %	Temp. °C	RAUPP
Sodium sulfide, aqueous	diluted	40	r
	diluted	60	r
	saturated	60	r
Spirits	com. avail.	20	r
Starch syrup	custom. conc.	60	r
Starch, aqueous	any	40	r
	any	60	r
Stearic acid	100	60	cr
Sulphur dioxide, aqueous under 8 atmospheric pressures	saturated	20	–
Sulphur dioxide, liquid	100	–10	–
	100	20	r
	100	60	r
Sulphur dioxide, moist and aqueous	any	40	r
	50	50	r
	any	60	r
	any	60	r
Sulphur dioxide, dry	any	60	r
Sulphuric acid, aqueous	up to 40	40	r
	up to 40	60	r
	70	20	r
	70	60	cr
	80–90	40	cr
	96	20	r
Table salt, aqueous	diluted	40	r
	diluted	60	r
	saturated	60	r
Tallow	100	20	r
	100	60	r
Tanigan extra A, aqueous	any	20	–
Tanigan extra B, aqueous	any	20	–
Tanigan extra D, aqueous	saturated	40	–
	saturated	60	–
Tanigan F, aqueous	saturated	60	–
Tanigan U, aqueous	saturated	40	–
	saturated	60	–
Tanning extracts, cellul.	common	20	r
Tanning extracts, natural	common	20	r

Reagent	Concentr. %	Temp. °C	RAUPP
Tartaric acid, aqueous	up to 10	40	r
	up to 10	60	r
	saturated	60	r
Thionyl chloride	100	20	nr
Tin (II) chloride, aqueous	diluted	40	r
	diluted	60	r
	saturated	60	r
Toluene	100	20	nr
Trichloroethylene	100	20	nr
Triethanolamine	100	20	r
Trilone	com. avail.	60	–
Trimethylolpropane, aqueous	up to 10	40	–
	up to 10	60	–
	com. avail.	40	r
	com. avail.	60	r
Urea, aqueous	up to 10	40	r
	up to 10	60	r
	33	60	r
Urine	normal	40	r
	normal	60	r
Vinegar (wine vinegar)	com. avail.	40	r
	com. avail.	50	r
	com. avail.	60	r
Vinyl acetate	100	20	r
Water	100		r
	100		r
Wax alcohol	100	60	cr
Wine, red and white	com. avail.	20	r
Xylene	100	20	nr
Yeast wort	custom. conc.	40	r
	custom. conc.	60	r
Zinc chloride, aqueous	diluted	40	r
	diluted	60	r
	saturated	60	r
Zinc sulphate, aqueous	diluted	40	r
	diluted	60	r
	saturated	60	r

RAUPIANO PLUS

Standards, regulations and guidelines

AS 1530.4

Method for fire tests on building materials, components and structures
Part 4: Fire-resistance test of elements of construction

AS 2887

Plastic waste fittings

AS/NZS 1260

PVC-U pipes and fittings for drain, waste and vent application

AS/NZS 2566.2

Buried flexible pipelines - Part 2: Installation

AS/NZS 3500.2

Plumbing and drainage
Part 2: Sanitary plumbing and drainage

AS/NZS 5065

Polyethylene and polypropylene pipes and fittings for drainage and sewerage applications

AS/NZS 7671

Plastic piping systems for soil and waste drainage (low and high temperature) inside buildings - Polypropylene (PP)

DIN 1054

Ground – Verification of the safety of earthworks and foundations

DIN 1055 Part 2

Design loads for buildings; soil characteristics; specific weight, angle of friction, cohesion, angle of wall friction

DIN 1986

Drainage systems on private ground

DIN 4060

Pipe joint assemblies with elastomer seals for use in drains and sewers, requirements and tests

DIN 4102

Fire behaviour of building materials and elements

DIN 4124

Excavations and trenches – Slopes, planking and strutting, breadths of working spaces

DIN EN 476

General requirements for components used in discharge pipes, drains and sewers for gravity systems

DIN EN 681

Elastomeric seals
Material requirements for pipe joint seals used in water and drainage applications

DIN EN 752

Drain and sewer systems outside buildings

DIN EN 1610

Construction and testing of drains and sewers

DIN EN 12056

Gravity drainage systems inside buildings

General building construction approval from the German Institute of Building Technology (DIBt)

Approval Z-42.1-223
RAUPIANO PLUS waste pipes and fittings



All schematic show general examples only and are not intended to satisfy the installation requirements for any particular project. For the installation of RAUPIANO PLUS waste water piping system, national and local codes, rules and regulations, as well as local conditions and the demands of the end use customer need to be considered.

APPENDIX A

RAUPIANO PLUS acoustic performance summary

RENZO TONIN ACOUSTIC LETTER



Consultants in Acoustics, Vibration & Structural Dynamics
 email: sydney@renzotonin.com.au
 website: www.renzotonin.com.au

TF126-02F02 (rev 0) Acoustic Performance of Raupiano Plus

21 October 2011

David Cole
 REHAU Pty Ltd
 Level 8, 1 Rider Boulevard
 Rhodes NSW 2138

Dear David

RE: ACOUSTIC PERFORMANCE OF RAUPIANO PLUS PIPEWORK

Renzo Tonin & Associates were engaged by Rehau to provide piping systems that satisfy the acoustic requirements of the Building Code of Australia (BCA). Specifically, develop forms of constructions incorporating the Raupiano Plus pipework with various plasterboard ceiling constructions that achieve $R_w+C_{v, 40}$ and $R_w+C_{v, 25}$ without any reliance on acoustic lagging. These forms of constructions were then tested in the laboratory for validation of their acoustic performance.

A series of acoustic tests were recently conducted (18/08/2011-25/08/2011) at the National Acoustical Laboratories, Chatswood NSW and our preliminary assessment of the test results show that the acoustic performance of the Raupiano Plus pipework in a system is equivalent to PVC pipework lagged with Pyrotek 4525C. The test results also show that the Raupiano Plus pipework conforms to the performance requirements of the BCA.

Yours faithfully,

RENZO TONIN & ASSOCIATES (NSW) PTY LTD

Nicholas Tselios

Director

Architectural & Building Acoustics Team



Sydney (Head Office)
Renzo Tonin & Associates (NSW) Pty Ltd
 ABN 29 117 462 861
 1/418A Elizabeth St., SURRY HILLS, NSW 2010
 PO Box 877 STRAWBERRY HILLS, NSW 2012
 Ph (02) 8218 0500 Fax (02) 8218 0501

Melbourne
 Brisbane
 Gold Coast
 Kuwait

ASK CONSULTING ACOUSTIC LETTER

ASK Consulting Engineers Pty Ltd

ABN: 55 622 586 522 - ACN: 128 491 967
PO Box 3901, South Brisbane. QLD. 4101.

P: 07-3255-3355 **F:** 07-3844-7180

W: www.askconsulting.com.au **E:** mail@askconsulting.com.au



30/08/2013

REHAU Pty Ltd

Level 8 | Rider Boulevard

Rhodes NSW 2138

Attention: David Cole

David,

Re: Acoustical Performance of Rehau Raupiano Plus Pipework

ASK Consulting Engineers Pty Ltd was engaged to undertake laboratory acoustical testing of the Rehau Raupiano Plus Pipework. Testing was conducted in the McLay Industries Acoustical Labs based in Brisbane which is compliant with all aspects of Australian Standard 1191-2002.

Testing was conducted to provide a direct comparison of noise emissions from waste pipes consisting of a HDPE pipe lagged with a 25mm foam and loaded vinyl (5kg/m²) product and a Raupiano Plus pipe in an un-lagged arrangement. The Rehau was also fitted with Rehau sound-dampening brackets. The pipes compared had identical configurations with bends and a fall height of approximately 500mm.

The comparative testing demonstrated that the Raupiano Plus Pipework emitted slightly lower noise levels than the lagged HDPE product when located behind a single layer of plasterboard representing the presence of a ceiling.

For the control of noise emissions from waste pipes in offices, education, health and defence buildings there are no specific BCA requirements. In these instances for the acoustical separation of the waste pipes is usually achieved by the application of a foam and loaded vinyl acoustic lagging acoustical treatment applied to waste pipes above acoustically sensitive spaces.

Based on the testing undertaken by ASK, in situations where waste pipe fall heights are 500mm or less and the pipe is contained within an enclosed ceiling space, the application of the Raupiano Plus pipe, fitted with Rehau sound-dampening brackets provides equivalent or lower levels of noise emission to a HDPE pipe lagged with a foam and loaded vinyl acoustical lagging.

On the basis of this testing the Rehau Raupiano Plus pipe system is considered as an acoustically satisfactory substitute to lagged HDPE in buildings where there are not specific BCA requirements and where fall heights are less than 500mm and the Rehau sound-dampening brackets are applied.

Yours faithfully

ASK Consulting Engineers Pty Ltd

Michael Lanchester

Associate

Ref: 6490L01V02.docx

Page 1 of 1

AECOM ACOUSTIC LETTER



AECOM Australia Pty Ltd
 Level 28
 81 King William Street
 Adelaide SA 5000
 Australia
 www.aecom.com

+61 8 7223 8400 tel
 +61 8 7223 5499 fax
 A&N 20 093 546 925

20 January 2014

Nick Luchero
 REHAU Pty Ltd
 464 Pulteney Street
 Adelaide
 SA 5000

Dear Nick

REHAU RAUPIANO in-situ acoustic testing

AECOM were engaged by REHAU to undertake acoustic testing of flow generated noise from waste water within RAUPIANO pipe work. Testing was undertaken in a purpose-built facility at Regency Park TAFE SA, Adelaide, South Australia between 22 October and 5 December 2013.

Testing was undertaken to allow comparison between REHAU RAUPIANO, PVC and HDPE pipe work, with and without Pyrotech 4525C pipework lagging for the following ceiling constructions, with and without R2.0 90 mm thick fibreglass batt ceiling insulation:

- 10 mm and 13 mm thick flushed plasterboard
- 10 mm thick Boral Endura vinyl faced plasterboard ceiling tiles (1200 mm x 600 mm)
- 18 mm thick Armstrong Fine Fissured ceiling tiles (1200 mm x 600 mm)
- 19 mm thick CSR USG Mars ClimatePlus ceiling tiles (1200 mm x 600 mm)

A wall construction of 13mm plasterboard with cavity insulation was also tested.

Three identical pipework layouts were used, each with a flow source of 9 Litres of water gravity fed from a toilet cistern. Spatial averaged measurements were undertaken within the test room, with all measurement data normalised to a test cell absorption area of 10m². An initial test with identical PVC pipe installations showed no significant difference in measured noise levels between the three pipework layouts within the test room.

We have formed the following conclusions based upon the test results:

- REHAU RAUPIANO will generally provide a lower noise level than lagged PVC and HDPE when installed within a ceiling space that has insulation laid above a flushed plasterboard, plasterboard tile, or mineral fibre tile ceiling.
- REHAU RAUPIANO will generally provide a noise level within 3 dB(A) of lagged PVC and HDPE when installed within a ceiling space that does not have insulation laid above a flushed plasterboard, plasterboard tile, or mineral fibre tile ceiling. However, we are of the opinion that this will generally not be noticeable to the human ear.
- REHAU RAUPIANO will provide a lower noise level than lagged PVC when installed within a wall cavity behind 13 mm plasterboard with cavity insulation.

In terms of noise emission we are of the opinion that REHAU RAUPIANO is a suitable alternative to lagged PVC or lagged HDPE when installed in combination with ceiling or wall constructions that are acoustically equivalent to those tested.

Yours faithfully

Simon Moore
 Principal Engineer - Acoustics
 simon.moore@aecom.com

NOTES

A series of 20 horizontal gray bars, stacked vertically, providing space for writing notes. The bars are evenly spaced and cover most of the page's width.

This document is protected by copyright. All rights based on this are reserved. No part of this publication may be translated, reproduced or transmitted in any form or by any similar means, electronic or mechanical, photocopying, recording or otherwise, or stored in a data retrieval system.

Our verbal and written advice relating to technical applications is based on experience and is to the best of our knowledge correct but is given without obligation. The use of REHAU products in conditions that are beyond our control or for applications other than those specified releases us from any obligation in regard to claims made in respect of the products. We recommend that the suitability of any REHAU product for the intended application should be checked. Utilisation and processing of our products are beyond our control and are therefore exclusively your responsibility. In the event that a liability is nevertheless considered, any compensation will be limited to the value of the goods supplied by us and used by you. Our warranty assumes consistent quality of our products in accordance with our specification and in accordance with our general conditions of sale.

REHAU Branches in Asia Pacific :

SINGAPORE - Regional Office for Asia Pacific

1 King George's Avenue, REHAU Building, Singapore 208557 Tel: +65 6392-6006 Fax: +65 6392-6116

AUSTRALIA National Customer Service Centre Tel: 1300 768 033 **GREATER CHINA** Beijing Tel: +86 10 6428-2956 Chengdu Tel: +86 28 8628-3218 Guangzhou Tel: +86 20 8776-0343 / 3646 Hong Kong Tel: +852 2898-7080 Qingdao Tel: +86 532 8667-8190 Shenyang Tel: +86 24 2287-5807 Shanghai Tel: +86 21 6355-1155 Taicang Tel: +86 512 5337-2888 Taipei Tel: +886 2 8780-3899 Xi'an Tel: +86 29 6859-7000 **INDIA** Bangalore Tel: +91 80 2222-0014 Mumbai Tel: +91 22 6148-5858 New Delhi Tel: +91 11 4848-5600 Pune Tel: + 91 21 3567-4301 / 4340 **INDONESIA** Jakarta Tel: +62 21 4587 1030 **JAPAN** Tokyo Tel: +81-3-3292-8337 **NEW ZEALAND** Auckland Tel: +64 9 2722-264 **PHILIPPINES** Manila Tel: +63 2 654-5120 **THAILAND** Bangkok Tel: +66 2763-5100 **VIETNAM** Ho Chi Minh City Tel: +84 8 3823-3030

www.rehau.com

Errors and changes are to be expected

ANZ019 BT 11.2016