

# 401 Thermal Awning Window Span Charts

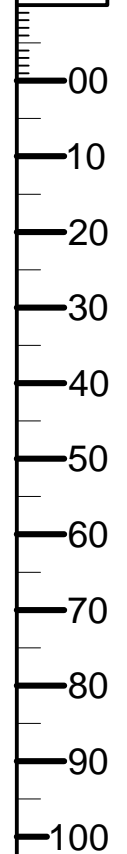

SPAN CHARTS 300 SERIES

REV#	DESCRIPTION	DATE
-	-	00/2013
-	-	00/2013
-	-	00/2013
-	-	00/00/2013

SPAN CHART

SCALE	NTS	
	NAME	DATE
DRAWN	ADM	05/10/17
CHECKED		



DRAWING No.  
300 SERIES SP

COPYRIGHT © 2011 MCKECHNIE ALUMINIUM SOLUTIONS LIMITED.  
PLEASE CHECK THAT ALL DETAILS ARE UP TO DATE BEFORE  
PROCEEDING. IF IN DOUBT ASK. AS ORIGINAL SIZE.

SECTION(S):  
J401015

DESCRIPTION:  
MULLION / TRANSOM

DATA:  
MOMENT OF INERTIA - 157348 mm<sup>4</sup>

DEFLECTION MAX:  
15mm

J401015

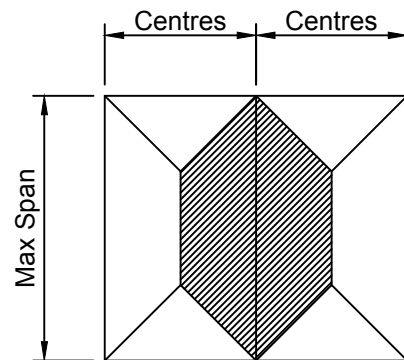
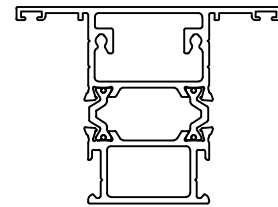

MULLION DATA - Mullion spacing and span calculations are to the current NZS 4211:2008  
Tables shall be used only where no Specific Design wind pressures are specified by the designers. The data provided is given for guidance only and the manufacturer takes no responsibility for incorrect interpretation. It is recommended that a qualified designer be consulted before fabrication.  
SPAN (m) - ULTIMATE (UWP) - SERVICEABILITY (SWP)  
SPAN / DEFLECTION (SPAN / DEF) = RESIDENTIAL 200 min

WIND ZONE :		LOW	MEDIUM	HIGH	VERY HIGH	EXTRA HIGH
SPAN / DEF. :		200	200	200	200	200
MULLION LOAD SPACING (m)	0.600	2.380	2.160	1.920	1.760	1.660
	0.800	2.160	1.960	1.740	1.600	1.500
	1.000	2.000	1.820	1.620	1.480	1.400
	1.200	1.880	1.720	1.520	1.400	1.300
	1.400	1.800	1.620	1.440	1.320	1.200
	1.600	1.720	1.560	1.380	1.240	1.120
	1.800	1.640	1.500	1.320	1.160	1.060
	2.000	1.580	1.440	1.260	1.100	1.000
	2.200	1.540	1.400	1.200	1.040	0.960
	2.400	1.500	1.360	1.140	1.000	0.920
2.600	1.460	1.300	1.100	0.960	0.880	

SECTION(S):  
J401016

DESCRIPTION:  
LIGHT BOX MULLION

DATA:  
MOMENT OF INERTIA - 291222 mm<sup>4</sup>

DEFLECTION MAX:  
15mm

J401016

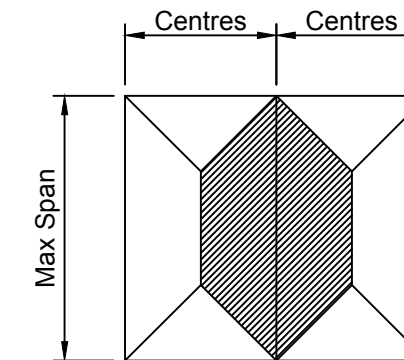
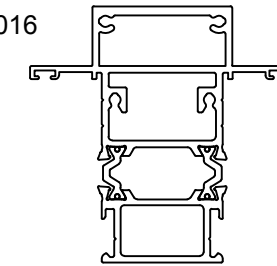

MULLION DATA - Mullion spacing and span calculations are to the current NZS 4211:2008  
Tables shall be used only where no Specific Design wind pressures are specified by the designers. The data provided is given for guidance only and the manufacturer takes no responsibility for incorrect interpretation. It is recommended that a qualified designer be consulted before fabrication.  
SPAN (m) - ULTIMATE (UWP) - SERVICEABILITY (SWP)  
SPAN / DEFLECTION (SPAN / DEF) = RESIDENTIAL 200 min

WIND ZONE :		LOW	MEDIUM	HIGH	VERY HIGH	EXTRA HIGH
SPAN / DEF. :		200	200	200	200	200
MULLION LOAD SPACING (m)	0.600	2.920	2.660	2.360	2.160	2.020
	0.800	2.660	2.420	2.140	1.960	1.840
	1.000	2.460	2.240	1.980	1.820	1.720
	1.200	2.320	2.100	1.860	1.720	1.560
	1.400	2.200	2.000	1.780	1.600	1.440
	1.600	2.100	1.920	1.700	1.500	1.360
	1.800	2.020	1.840	1.600	1.400	1.280
	2.000	1.960	1.780	1.520	1.340	1.200
	2.200	1.900	1.720	1.440	1.260	1.160
	2.400	1.840	1.640	1.380	1.220	1.100
2.600	1.780	1.580	1.320	1.160	1.060	

REV#	DESCRIPTION	DATE
A	Moment Shown For J401016 Corrected	08/08/16

## Thermal - Span Charts

SCALE	1:2 @ A3
NAME	
DRAWN	T.C 05/2015
CHECKED	M.C 00/2015



DRAWING No.

401.3.1

SECTION(S):  
J401017

DESCRIPTION:  
MEDIUM BOX MULLION

DATA:  
MOMENT OF INERTIA - 451462 mm<sup>4</sup>

DEFLECTION MAX:  
15mm

J401017

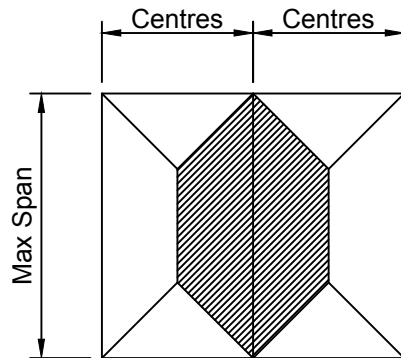
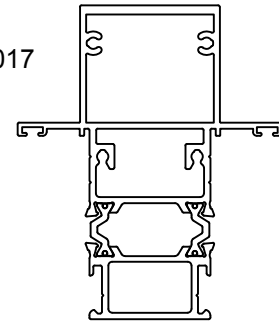

MULLION DATA - Mullion spacing and span calculations are to the current NZS 4211:2008  
Tables shall be used only where no Specific Design wind pressures are specified by the designers. The data provided is given for guidance only and the manufacturer takes no responsibility for incorrect interpretation. It is recommended that a qualified designer be consulted before fabrication.  
SPAN (m) - ULTIMATE (UWP) - SERVICEABILITY (SWP)  
SPAN / DEFLECTION (SPAN / DEF) = RESIDENTIAL 200 min

WIND ZONE :		LOW	MEDIUM	HIGH	VERY HIGH	EXTRA HIGH
SPAN / DEF. :		200	200	200	200	200
MULLION LOAD SPACING (m)	0.600	3.280	3.060	2.720	2.500	2.360
	0.800	3.060	2.800	2.480	2.280	2.140
	1.000	2.860	2.600	2.300	2.120	1.980
	1.200	2.680	2.440	2.160	1.980	1.840
	1.400	2.540	2.320	2.060	1.860	1.700
	1.600	2.440	2.220	1.960	1.740	1.580
	1.800	2.340	2.120	1.880	1.640	1.500
	2.000	2.260	2.060	1.780	1.560	1.420
	2.200	2.200	1.980	1.700	1.480	1.360
	2.400	2.120	1.940	1.620	1.420	1.300
2.600	2.080	1.860	1.560	1.360	1.240	

SECTION(S):  
J401018

DESCRIPTION:  
HEAVY BOX BACK MULLION

DATA:  
MOMENT OF INERTIA - 786638 mm<sup>4</sup>

DEFLECTION MAX:  
15mm

J401018

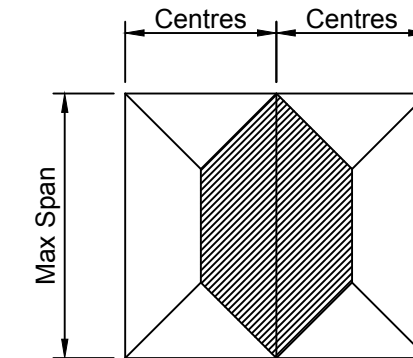
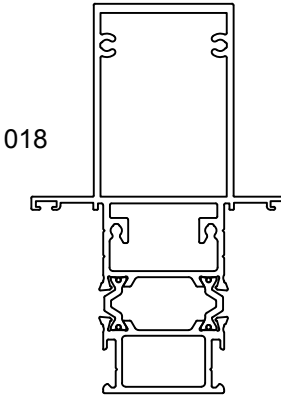

MULLION DATA - Mullion spacing and span calculations are to the current NZS 4211:2008  
Tables shall be used only where no Specific Design wind pressures are specified by the designers. The data provided is given for guidance only and the manufacturer takes no responsibility for incorrect interpretation. It is recommended that a qualified designer be consulted before fabrication.  
SPAN (m) - ULTIMATE (UWP) - SERVICEABILITY (SWP)  
SPAN / DEFLECTION (SPAN / DEF) = RESIDENTIAL 200 min

WIND ZONE :		LOW	MEDIUM	HIGH	VERY HIGH	EXTRA HIGH
SPAN / DEF. :		200	200	200	200	200
MULLION LOAD SPACING (m)	0.600	3.780	3.500	3.200	3.020	2.840
	0.800	3.500	3.260	2.980	2.740	2.580
	1.000	3.320	3.080	2.780	2.540	2.380
	1.200	3.160	2.940	2.600	2.400	2.220
	1.400	3.040	2.780	2.480	2.260	2.040
	1.600	2.940	2.660	2.360	2.100	1.920
	1.800	2.820	2.560	2.260	1.980	1.800
	2.000	2.720	2.480	2.140	1.880	1.720
	2.200	2.640	2.400	2.040	1.800	1.640
	2.400	2.560	2.320	1.960	1.720	1.560
2.600	2.500	2.240	1.880	1.660	1.500	

REV#	DESCRIPTION	DATE

### Thermal - Span Charts

SCALE	1:2 @ A3
NAME	DATE
DRAWN	T.C 05/2015
CHECKED	M.C 00/2015



DRAWING No.

401.3.2

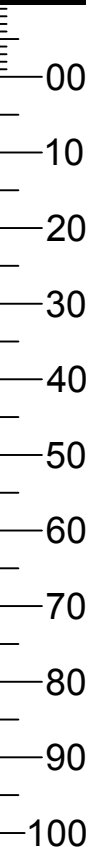

SECTION(S):  
J401014

DESCRIPTION:  
FINNED MULLION

DATA:  
MOMENT OF INERTIA - 621872 mm<sup>4</sup>

DEFLECTION MAX:  
15mm

J401014

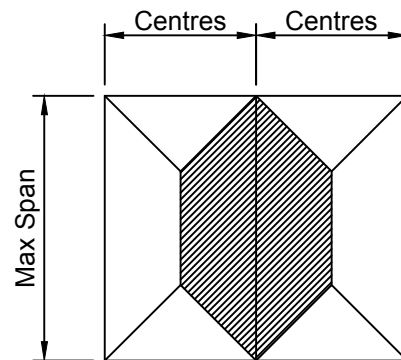
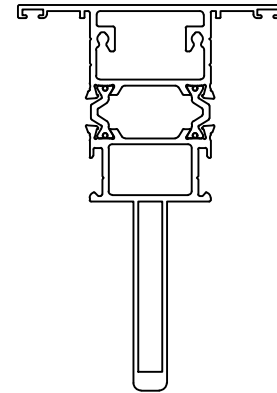

MULLION DATA - Mullion spacing and span calculations are to the current NZS 4211:2008  
Tables shall be used only where no Specific Design wind pressures are specified by the designers. The data provided is given for guidance only and the manufacturer takes no responsibility for incorrect interpretation. It is recommended that a qualified designer be consulted before fabrication.  
SPAN (m) - ULTIMATE (UWP) - SERVICEABILITY (SWP)  
SPAN / DEFLECTION (SPAN / DEF) = RESIDENTIAL 200 min

WIND ZONE :		LOW	MEDIUM	HIGH	VERY HIGH	EXTRA HIGH
SPAN / DEF. :		200	200	200	200	200
MULLION LOAD SPACING (m)	0.600	3.560	3.300	3.020	2.800	2.620
	0.800	3.300	3.080	2.760	2.540	2.380
	1.000	3.120	2.880	2.560	2.360	2.200
	1.200	2.980	2.720	2.400	2.220	2.080
	1.400	2.840	2.580	2.280	2.100	1.980
	1.600	2.720	2.460	2.180	2.000	1.880
	1.800	2.600	2.360	2.100	1.940	1.820
	2.000	2.520	2.280	2.040	1.860	1.740
	2.200	2.440	2.220	1.960	1.800	1.700
	2.400	2.360	2.160	1.900	1.760	1.640
2.600	2.300	2.100	1.860	1.700	1.600	

SECTION(S):  
J401019

DESCRIPTION:  
FINNED HEAVY BOX BACK MULLION

DATA:  
MOMENT OF INERTIA - 1677051 mm<sup>4</sup>

DEFLECTION MAX:  
15mm

J401019

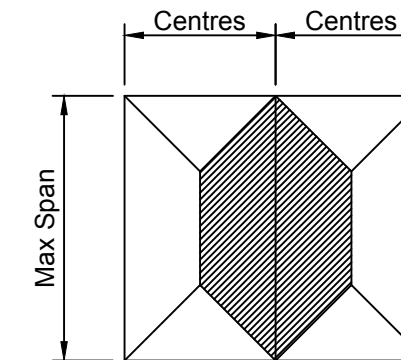
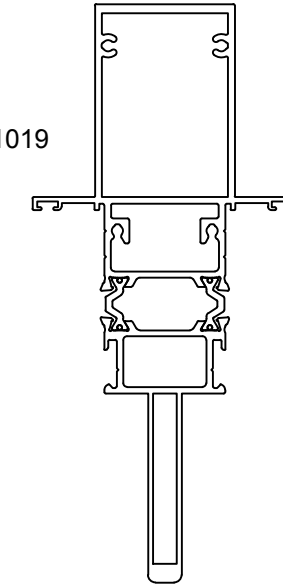

MULLION DATA - Mullion spacing and span calculations are to the current NZS 4211:2008  
Tables shall be used only where no Specific Design wind pressures are specified by the designers. The data provided is given for guidance only and the manufacturer takes no responsibility for incorrect interpretation. It is recommended that a qualified designer be consulted before fabrication.  
SPAN (m) - ULTIMATE (UWP) - SERVICEABILITY (SWP)  
SPAN / DEFLECTION (SPAN / DEF) = RESIDENTIAL 200 min

WIND ZONE :		LOW	MEDIUM	HIGH	VERY HIGH	EXTRA HIGH
SPAN / DEF. :		200	200	200	200	200
MULLION LOAD SPACING (m)	0.600	4.560	4.240	3.880	3.640	3.460
	0.800	4.240	3.940	3.620	3.380	3.220
	1.000	4.020	3.740	3.420	3.200	3.060
	1.200	3.840	3.560	3.260	3.060	2.900
	1.400	3.680	3.420	3.140	2.920	2.740
	1.600	3.560	3.320	3.040	2.800	2.620
	1.800	3.460	3.220	2.940	2.700	2.520
	2.000	3.380	3.140	2.820	2.600	2.440
	2.200	3.300	3.060	2.740	2.520	2.360
	2.400	3.220	3.000	2.660	2.440	2.300
2.600	3.160	2.920	2.600	2.380	2.240	

REV#	DESCRIPTION	DATE
A	Tables Updated	24/08/16

### Thermal - Span Charts

SCALE	1:2 @ A3
NAME	DATE
DRAWN	T.C 05/2015
CHECKED	M.C 00/2015



DRAWING No. 401.3.3

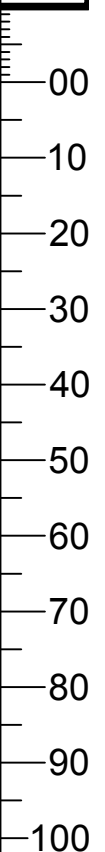

SECTION(S):  
J401300

DESCRIPTION:  
ARCHITECTURAL BOX BACK MULLION

DATA:  
MOMENT OF INERTIA - 2008428 mm<sup>4</sup>

DEFLECTION MAX:  
15mm

J401300

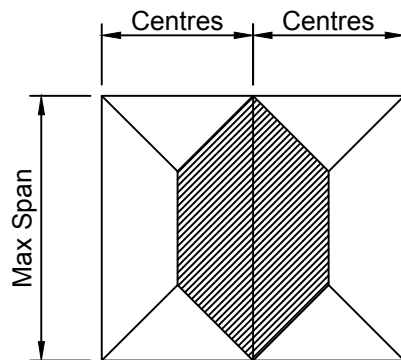
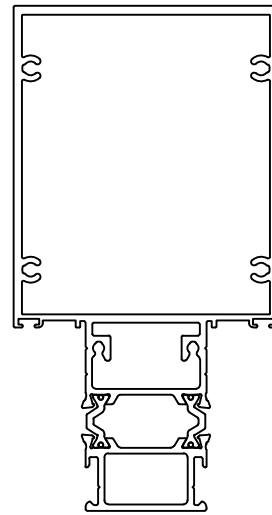

MULLION DATA - Mullion spacing and span calculations are to the current NZS 4211:2008  
Tables shall be used only where no Specific Design wind pressures are specified by the designers. The data provided is given for guidance only and the manufacturer takes no responsibility for incorrect interpretation. It is recommended that a qualified designer be consulted before fabrication.  
SPAN (m) - ULTIMATE (UWP) - SERVICEABILITY (SWP)  
SPAN / DEFLECTION (SPAN / DEF) = RESIDENTIAL 200 min

WIND ZONE :		LOW	MEDIUM	HIGH	VERY HIGH	EXTRA HIGH
SPAN / DEF. :		200	200	200	200	200
MULLION LOAD SPACING (m)	0.600	4.760	4.440	4.060	3.800	3.640
	0.800	4.440	4.120	3.780	3.540	3.380
	1.000	4.200	3.900	3.580	3.360	3.200
	1.200	4.000	3.720	3.420	3.200	3.060
	1.400	3.860	3.580	3.280	3.080	2.920
	1.600	3.720	3.480	3.180	2.980	2.800
	1.800	3.620	3.360	3.080	2.860	2.680
	2.000	3.520	3.280	3.000	2.760	2.580
	2.200	3.440	3.200	2.920	2.680	2.500
	2.400	3.360	3.140	2.820	2.600	2.440
2.600	3.300	3.080	2.760	2.520	2.380	

SECTION(S):  
J401301

DESCRIPTION:  
ARCHITECTURAL FINNED BOX BACK MULLION

DATA:  
MOMENT OF INERTIA - 3410974 mm<sup>4</sup>

DEFLECTION MAX:  
15mm

J401301

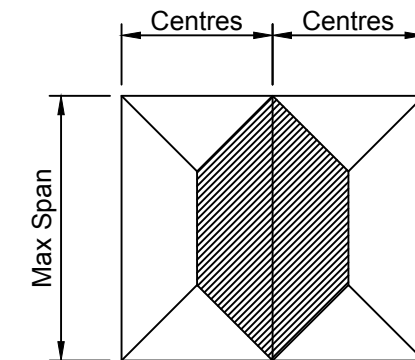
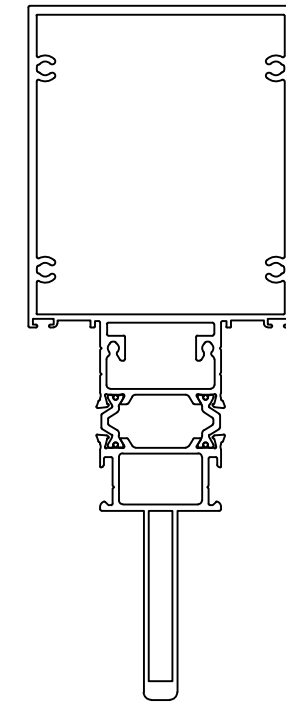

MULLION DATA - Mullion spacing and span calculations are to the current NZS 4211:2008  
Tables shall be used only where no Specific Design wind pressures are specified by the designers. The data provided is given for guidance only and the manufacturer takes no responsibility for incorrect interpretation. It is recommended that a qualified designer be consulted before fabrication.  
SPAN (m) - ULTIMATE (UWP) - SERVICEABILITY (SWP)  
SPAN / DEFLECTION (SPAN / DEF) = RESIDENTIAL 200 min

WIND ZONE :		LOW	MEDIUM	HIGH	VERY HIGH	EXTRA HIGH
SPAN / DEF. :		200	200	200	200	200
MULLION LOAD SPACING (m)	0.600	5.440	5.060	4.640	4.360	4.140
	0.800	5.060	4.720	4.320	4.040	3.860
	1.000	4.800	4.460	4.080	3.820	3.640
	1.200	4.580	4.260	3.900	3.660	3.480
	1.400	4.400	4.100	3.740	3.520	3.360
	1.600	4.260	3.960	3.620	3.400	3.240
	1.800	4.140	3.840	3.520	3.300	3.140
	2.000	4.020	3.740	3.420	3.220	3.060
	2.200	3.940	3.660	3.340	3.140	3.000
	2.400	3.840	3.580	3.280	3.080	2.900
2.600	3.780	3.500	3.220	3.020	2.840	

REV#	DESCRIPTION	DATE
A	Tables Updated	24/08/16
B	J401301 Added	18/11/16

## Thermal - Span Charts

SCALE	1:2 @ A3
NAME	DATE
DRAWN	T.C 05/2015
CHECKED	M.C 00/2015



DRAWING No.

401.3.4

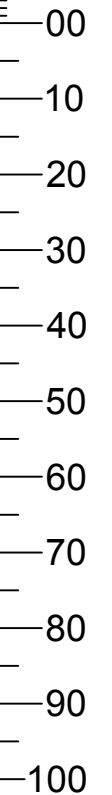

# 402

# Thermal Replacement Windows Span Charts

SPAN CHARTS 300 SERIES

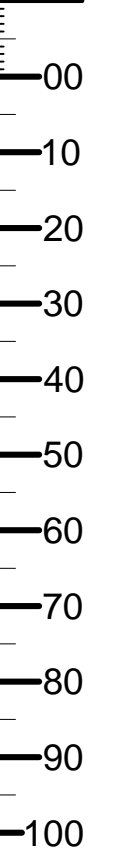

REV#	DESCRIPTION	DATE
-	-	00/2013
-	-	00/2013
-	-	00/2013
-	-	00/00/2013

SPAN CHART

SCALE	NTS	
	NAME	DATE
DRAWN	ADM	05/10/17
CHECKED		

**O MEGA**  
WINDOWS + DOORS

DRAWING No.  
**300 SERIES SP**

COPYRIGHT © 2011 MCKECHNIE ALUMINIUM SOLUTIONS LIMITED.  
PLEASE CHECK THAT ALL DETAILS ARE UP TO DATE BEFORE  
PROCEEDING. IF IN DOUBT ASK. AS ORIGINAL SIZE.

SECTION(S):  
J401102

DESCRIPTION:  
Replacement Frame Mullion

DATA:  
MOMENT OF INERTIA - 238433 mm<sup>4</sup>

DEFLECTION MAX:  
15mm

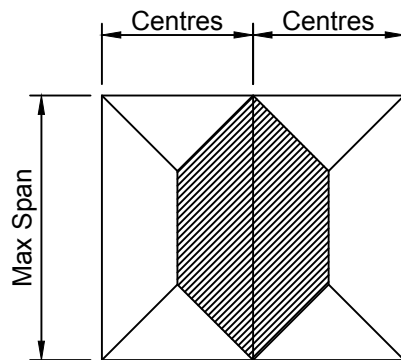
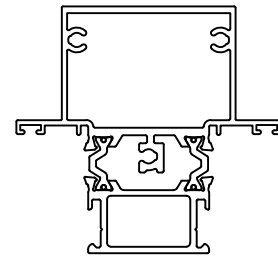

MULLION DATA - Mullion spacing and span calculations are to the current NZS 4211:2008  
Tables shall be used only where no Specific Design wind pressures are specified by the designers. The data provided is given for guidance only and the manufacturer takes no responsibility for incorrect interpretation. It is recommended that a qualified designer be consulted before fabrication.  
SPAN (m) - ULTIMATE (UWP) - SERVICEABILITY (SWP)  
SPAN / DEFLECTION (SPAN / DEF) = RESIDENTIAL 200 min

WIND ZONE :		LOW	MEDIUM	HIGH	VERY HIGH	EXTRA HIGH
SPAN / DEF. :		200	200	200	200	200
MULLION LOAD SPACING (m)	0.600	2.740	2.480	2.200	2.020	1.900
	0.800	2.480	2.260	2.000	1.840	1.720
	1.000	2.300	2.100	1.860	1.700	1.600
	1.200	2.160	1.960	1.740	1.600	1.500
	1.400	2.060	1.860	1.660	1.520	1.420
	1.600	1.960	1.780	1.580	1.460	1.320
	1.800	1.900	1.720	1.520	1.380	1.240
	2.000	1.820	1.660	1.480	1.300	1.180
	2.200	1.760	1.600	1.420	1.240	1.120
	2.400	1.720	1.560	1.360	1.180	1.080
2.600	1.680	1.520	1.300	1.140	1.040	

SECTION(S):  
J401103

DESCRIPTION:  
Replacement Frame Transom

DATA:  
MOMENT OF INERTIA - 72320 mm<sup>4</sup>

DEFLECTION MAX:  
15mm

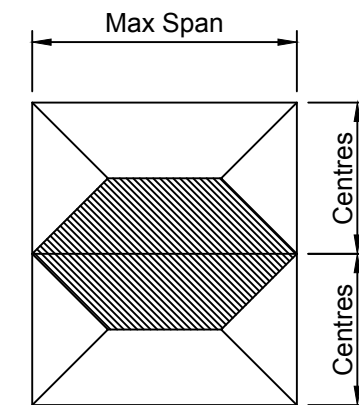
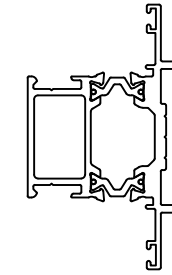

MULLION DATA - Mullion spacing and span calculations are to the current NZS 4211:2008  
Tables shall be used only where no Specific Design wind pressures are specified by the designers. The data provided is given for guidance only and the manufacturer takes no responsibility for incorrect interpretation. It is recommended that a qualified designer be consulted before fabrication.  
SPAN (m) - ULTIMATE (UWP) - SERVICEABILITY (SWP)  
SPAN / DEFLECTION (SPAN / DEF) = RESIDENTIAL 200 min

WIND ZONE :		LOW	MEDIUM	HIGH	VERY HIGH	EXTRA HIGH
SPAN / DEF. :		200	200	200	200	200
MULLION LOAD SPACING (m)	0.600	1.840	1.660	1.480	1.360	1.280
	0.800	1.660	1.520	1.340	1.240	1.160
	1.000	1.540	1.400	1.240	1.140	1.080
	1.200	1.460	1.320	1.180	1.080	1.000
	1.400	1.380	1.260	1.120	1.000	0.920
	1.600	1.320	1.200	1.060	0.940	0.860
	1.800	1.260	1.160	1.020	0.880	0.800
	2.000	1.220	1.120	0.960	0.840	0.760
	2.200	1.180	1.080	0.920	0.800	0.720
	2.400	1.160	1.040	0.880	0.760	0.700
2.600	1.120	1.000	0.840	0.740	0.680	

REV#	DESCRIPTION	DATE

## SPAN CHARTS

SCALE	1:2 @ A3
NAME	
DRAWN	T.C 05/2015
CHECKED	M.C 00/2015



DRAWING No.

402.3.1

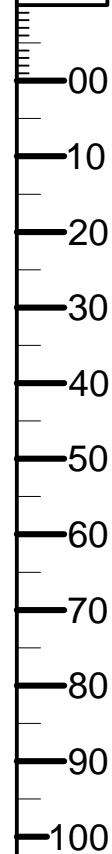

# 409

# Thermal Hinged Doors Span Charts

REV#	DESCRIPTION	DATE
-	-	00/2013
-	-	00/2013
-	-	00/2013
-	-	00/00/2013

SPAN CHART

SCALE	NTS	
	NAME	DATE
DRAWN	ADM	05/10/17
CHECKED		



DRAWING No. 300 SERIES SP



SECTION(S):  
J409016 + J409015

DESCRIPTION:  
FRENCH DOOR

DATA:  
MOMENT OF INERTIA - 715279 mm<sup>4</sup>  
Note Moment Achieved With Multi Point Locking

DEFLECTION MAX:  
15mm

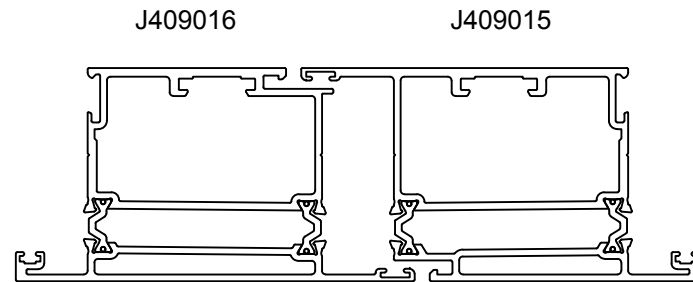

SECTION(S):  
J409005 + J409014

DESCRIPTION:  
SIDE LIGHT MULLION

DATA:  
MOMENT OF INERTIA - 901500 mm<sup>4</sup>  
Note Moment Achieved With Multi Point Locking

DEFLECTION MAX:  
15mm

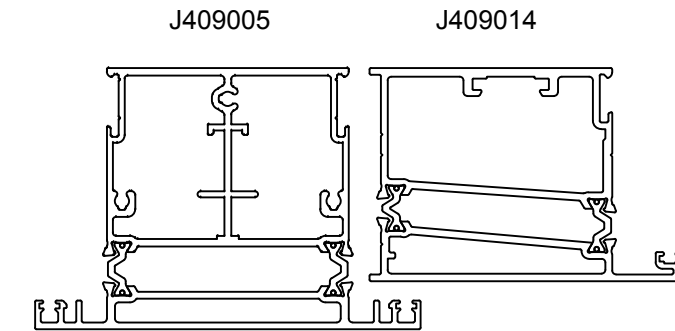

MULLION DATA - Mullion spacing and span calculations are to the current NZS 4211:2008  
Tables shall be used only where no Specific Design wind pressures are specified by the designers. The data provided is given for guidance only and the manufacturer takes no responsibility for incorrect interpretation. It is recommended that a qualified designer be consulted before fabrication.  
SPAN (m) - ULTIMATE (UWP) - SERVICEABILITY (SWP)  
SPAN / DEFLECTION (SPAN / DEF) = RESIDENTIAL 200 min

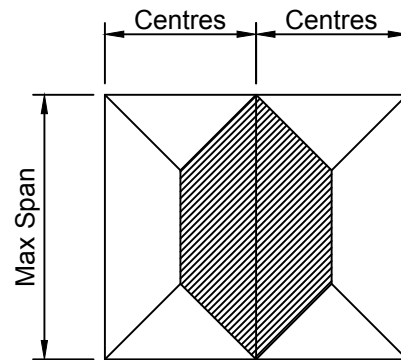

MULLION DATA - Mullion spacing and span calculations are to the current NZS 4211:2008  
Tables shall be used only where no Specific Design wind pressures are specified by the designers. The data provided is given for guidance only and the manufacturer takes no responsibility for incorrect interpretation. It is recommended that a qualified designer be consulted before fabrication.  
SPAN (m) - ULTIMATE (UWP) - SERVICEABILITY (SWP)  
SPAN / DEFLECTION (SPAN / DEF) = RESIDENTIAL 200 min

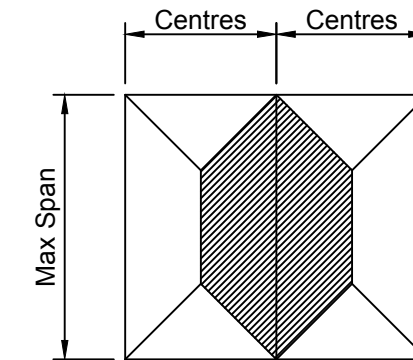

WIND ZONE :		LOW	MEDIUM	HIGH	VERY HIGH	EXTRA HIGH
SPAN / DEF. :		200	200	200	200	200
MULLION LOAD SPACING (m)	0.600	3.680	3.420	3.140	2.920	2.740
	0.800	3.420	3.180	2.900	2.660	2.500
	1.000	3.240	3.020	2.680	2.460	2.320
	1.200	3.100	2.840	2.520	2.320	2.180
	1.400	2.980	2.700	2.400	2.200	2.060
	1.600	2.840	2.580	2.300	2.100	1.980
	1.800	2.740	2.480	2.200	2.020	1.900
	2.000	2.640	2.400	2.120	1.960	1.840
	2.200	2.560	2.320	2.060	1.900	1.780
	2.400	2.480	2.260	2.000	1.840	1.720
2.600	2.420	2.200	1.940	1.780	1.680	

WIND ZONE :		LOW	MEDIUM	HIGH	VERY HIGH	EXTRA HIGH
SPAN / DEF. :		200	200	200	200	200
MULLION LOAD SPACING (m)	0.600	3.900	3.640	3.320	3.120	2.960
	0.800	3.640	3.380	3.080	2.860	2.700
	1.000	3.440	3.200	2.900	2.660	2.500
	1.200	3.280	3.060	2.720	2.500	2.340
	1.400	3.160	2.920	2.600	2.380	2.240
	1.600	3.060	2.800	2.480	2.280	2.140
	1.800	2.960	2.680	2.380	2.180	2.060
	2.000	2.860	2.580	2.300	2.120	1.980
	2.200	2.760	2.500	2.220	2.040	1.920
	2.400	2.680	2.440	2.160	1.980	1.860
2.600	2.620	2.380	2.100	1.940	1.820	

REV#	DESCRIPTION	DATE

### Thermal - Span Charts

SCALE	1:2 @ A3
NAME	
DRAWN	T.C 05/2015
CHECKED	M.C 00/2015



DRAWING No.

409.3.1

COPYRIGHT © 2011 MCKECHNIE ALUMINIUM SOLUTIONS LIMITED.  
 PLEASE CHECK THAT ALL DETAILS ARE UP TO DATE BEFORE  
 PROCEEDING. IF IN DOUBT ASK.

Thermal Entrance Door

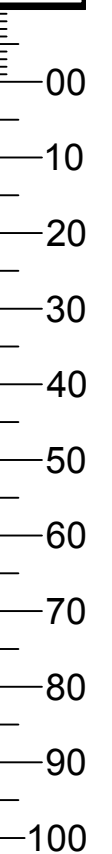

SECTION(S):  
J409005 + J409018

DESCRIPTION:  
SIDE LIGHT MULLION (Wide Lock Stile)

DATA:  
MOMENT OF INERTIA - 1013885 mm<sup>4</sup>  
Note Moment Achieved With Multi Point Locking

DEFLECTION MAX:  
15mm

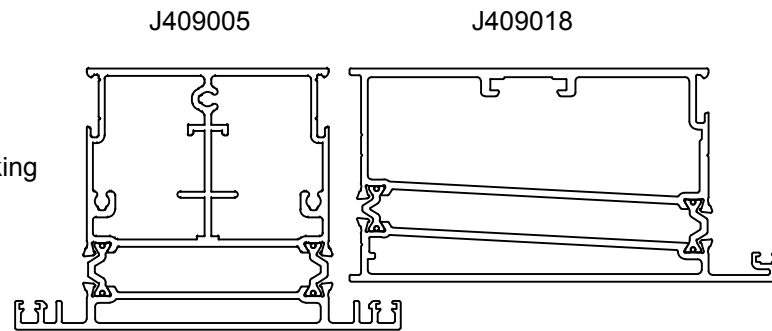

SECTION(S):  
J409014 + J409001 + J409079 + J409000

DESCRIPTION:  
COUPLED SIDE LIGHT MULLION

DATA:  
MOMENT OF INERTIA - 1639660 mm<sup>4</sup>  
Note Moment Achieved With Multi Point Locking

DEFLECTION MAX:  
15mm

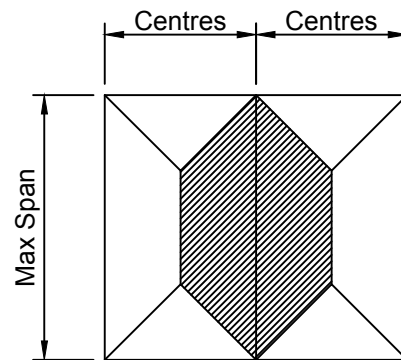
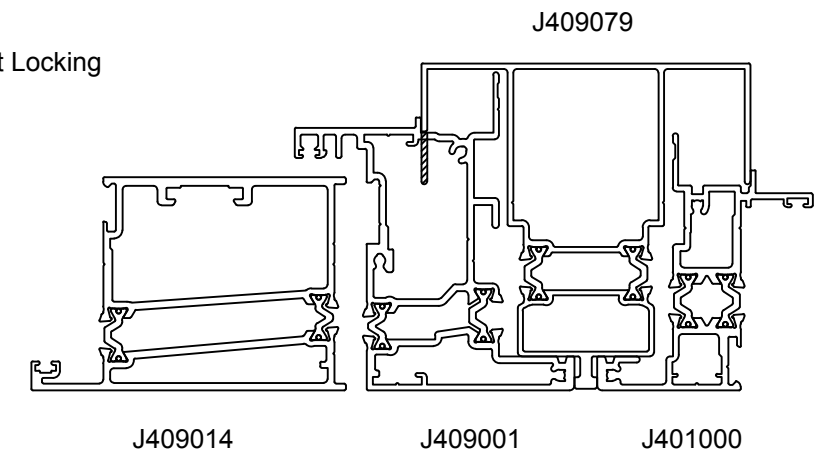

MULLION DATA - Mullion spacing and span calculations are to the current NZS 4211:2008  
Tables shall be used only where no Specific Design wind pressures are specified by the designers. The data provided is given for guidance only and the manufacturer takes no responsibility for incorrect interpretation. It is recommended that a qualified designer be consulted before fabrication.  
SPAN (m) - ULTIMATE (UWP) - SERVICEABILITY (SWP)  
SPAN / DEFLECTION (SPAN / DEF) = RESIDENTIAL 200 min

MULLION DATA - Mullion spacing and span calculations are to the current NZS 4211:2008  
Tables shall be used only where no Specific Design wind pressures are specified by the designers. The data provided is given for guidance only and the manufacturer takes no responsibility for incorrect interpretation. It is recommended that a qualified designer be consulted before fabrication.  
SPAN (m) - ULTIMATE (UWP) - SERVICEABILITY (SWP)  
SPAN / DEFLECTION (SPAN / DEF) = RESIDENTIAL 200 min

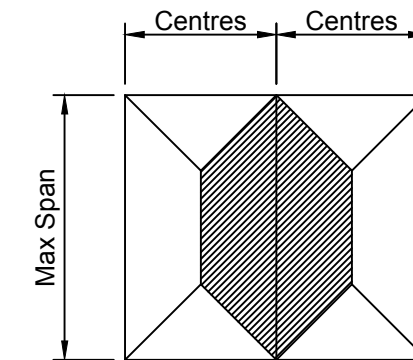

WIND ZONE :	LOW	MEDIUM	HIGH	VERY HIGH	EXTRA HIGH	
SPAN / DEF. :	200	200	200	200	200	
MULLION LOAD SPACING (m)	0.600	4.020	3.740	3.420	3.200	3.060
	0.800	3.740	3.480	3.180	2.980	2.800
	1.000	3.540	3.280	3.000	2.780	2.600
	1.200	3.380	3.140	2.840	2.600	2.440
	1.400	3.240	3.020	2.700	2.480	2.320
	1.600	3.140	2.900	2.580	2.360	2.220
	1.800	3.060	2.780	2.480	2.280	2.140
	2.000	2.960	2.700	2.400	2.200	2.060
	2.200	2.880	2.600	2.320	2.120	2.000
	2.400	2.780	2.540	2.240	2.060	1.940
2.600	2.720	2.460	2.200	2.020	1.880	

WIND ZONE :	LOW	MEDIUM	HIGH	VERY HIGH	EXTRA HIGH	
SPAN / DEF. :	200	200	200	200	200	
MULLION LOAD SPACING (m)	0.600	4.540	4.220	3.860	3.620	3.460
	0.800	4.220	3.920	3.580	3.360	3.220
	1.000	3.980	3.720	3.400	3.180	3.040
	1.200	3.820	3.540	3.240	3.040	2.880
	1.400	3.660	3.420	3.120	2.900	2.720
	1.600	3.540	3.300	3.020	2.780	2.600
	1.800	3.440	3.200	2.900	2.680	2.500
	2.000	3.360	3.120	2.800	2.580	2.420
	2.200	3.280	3.040	2.720	2.500	2.340
	2.400	3.200	2.980	2.640	2.420	2.280
2.600	3.140	2.900	2.580	2.360	2.220	

REV#	DESCRIPTION	DATE
A	Span Chart Added	10/07/17

## Thermal - Span Charts

SCALE	1:2 @ A3
NAME	
DATE	
DRAWN	T.C
CHECKED	M.C



DRAWING No.

409.3.2

COPYRIGHT © 2011 MCKECHNIE ALUMINIUM SOLUTIONS LIMITED.  
 PLEASE CHECK THAT ALL DETAILS ARE UP TO DATE BEFORE  
 PROCEEDING. IF IN DOUBT ASK.

Thermal Entrance Door

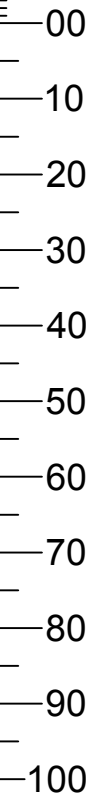

**SECTION(S):**

J409018 + J409001 + J409079 + J409000

**DESCRIPTION:**

COUPLED SIDE LIGHT MULLION (Wide Lock Stile)

**DATA:**

MOMENT OF INERTIA - 1752045 mm<sup>4</sup>

Note Moment Achieved With Multi Point Locking

**DEFLECTION MAX:**

15mm

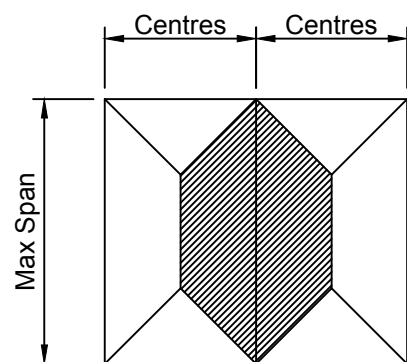
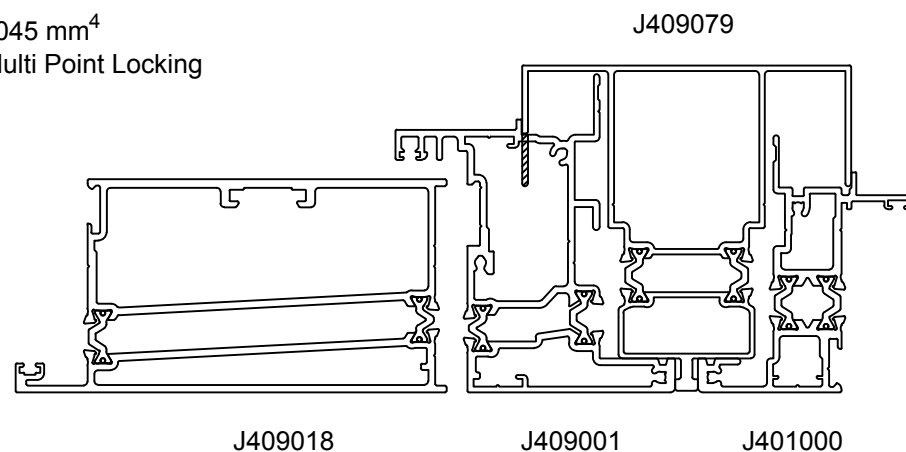

MULLION DATA - Mullion spacing and span calculations are to the current NZS 4211:2008  
 Tables shall be used only where no Specific Design wind pressures are specified by the designers. The data provided is given for guidance only and the manufacturer takes no responsibility for incorrect interpretation. It is recommended that a qualified designer be consulted before fabrication.  
 SPAN (m) - ULTIMATE (UWP) - SERVICEABILITY (SWP)  
 SPAN / DEFLECTION (SPAN / DEF) = RESIDENTIAL 200 min

WIND ZONE :		LOW	MEDIUM	HIGH	VERY HIGH	EXTRA HIGH
SPAN / DEF. :		200	200	200	200	200
MULLION LOAD SPACING (m)	0.600	4.600	4.280	3.920	3.680	3.500
	0.800	4.280	4.000	3.660	3.420	3.260
	1.000	4.060	3.780	3.460	3.240	3.080
	1.200	3.880	3.600	3.300	3.100	2.940
	1.400	3.720	3.460	3.180	2.980	2.780
	1.600	3.600	3.360	3.060	2.840	2.660
	1.800	3.500	3.260	2.980	2.740	2.560
	2.000	3.400	3.180	2.880	2.640	2.480
	2.200	3.320	3.100	2.780	2.560	2.400
	2.400	3.260	3.020	2.700	2.480	2.320
2.600	3.200	2.960	2.640	2.420	2.260	

REV#	DESCRIPTION	DATE
A	Original Page Now 409.3.4	10/07/17

**Thermal - Span Charts**

SCALE	1:2 @ A3
NAME	
DRAWN	T.C
CHECKED	M.C



DRAWING No.

409.3.3

COPYRIGHT © 2011 MCKECHNIE ALUMINIUM SOLUTIONS LIMITED.  
 PLEASE CHECK THAT ALL DETAILS ARE UP TO DATE BEFORE  
 PROCEEDING. IF IN DOUBT ASK.

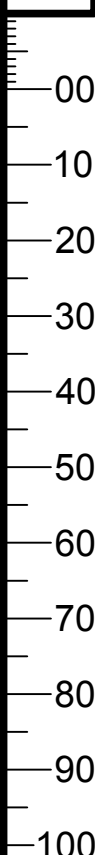

Thermal Entrance Door

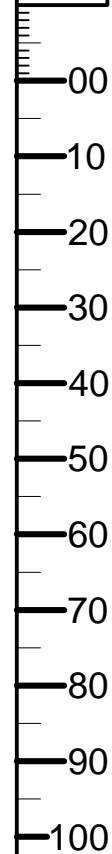

# 411

# Thermal

# Sliding Doors

# Span Charts

REV#	DESCRIPTION	DATE
-	-	00/2013
-	-	00/2013
-	-	00/2013
-	-	00/00/2013

SPAN CHART

SCALE	NTS	
	NAME	DATE
DRAWN	ADM	05/10/17
CHECKED		



DRAWING No. 300 SERIES SP

SECTION(S):  
J411016 + J411008

DESCRIPTION:  
SLIDING DOOR MULLION INTERLOCKER  
JUNCTION

DATA:  
MOMENT OF INERTIA - 571909 mm<sup>4</sup>

DEFLECTION MAX:  
15mm

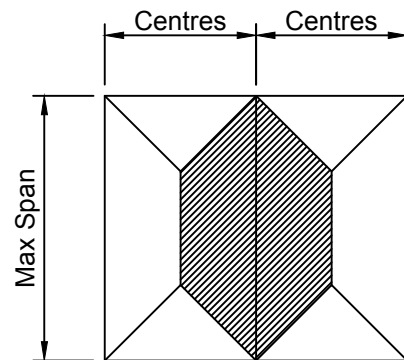
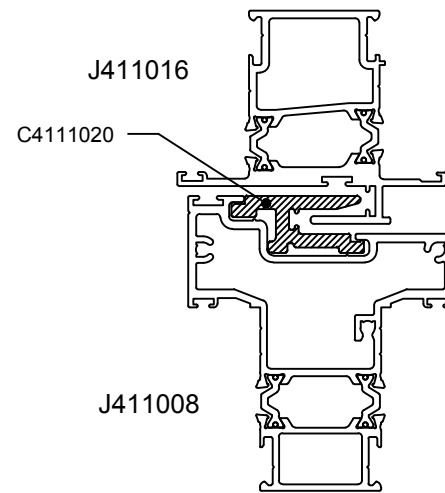

MULLION DATA - Mullion spacing and span calculations are to the current NZS 4211:2008  
Tables shall be used only where no Specific Design wind pressures are specified by the designers. The data provided is given for guidance only and the manufacturer takes no responsibility for incorrect interpretation. It is recommended that a qualified designer be consulted before fabrication.  
SPAN (m) - ULTIMATE (UWP) - SERVICEABILITY (SWP)  
SPAN / DEFLECTION (SPAN / DEF) = RESIDENTIAL 200 min

WIND ZONE :	LOW	MEDIUM	HIGH	VERY HIGH	EXTRA HIGH	
SPAN / DEF. :	200	200	200	200	200	
MULLION LOAD SPACING (m)	0.600	3.480	3.240	2.960	2.720	2.540
	0.800	3.240	3.020	2.680	2.460	2.320
	1.000	3.060	2.800	2.480	2.280	2.140
	1.200	2.900	2.640	2.340	2.160	2.020
	1.400	2.760	2.500	2.220	2.040	1.920
	1.600	2.640	2.400	2.120	1.960	1.840
	1.800	2.540	2.300	2.040	1.880	1.760
	2.000	2.440	2.220	1.980	1.820	1.700
	2.200	2.380	2.160	1.920	1.760	1.640
	2.400	2.300	2.100	1.860	1.700	1.600
2.600	2.240	2.040	1.800	1.660	1.560	

SECTION(S):  
J411016 + J411012

DESCRIPTION:  
SLIDING DOOR FINNED MULLION  
INTERLOCKER JUNCTION

DATA:  
MOMENT OF INERTIA - 1305192 mm<sup>4</sup>

DEFLECTION MAX:  
15mm

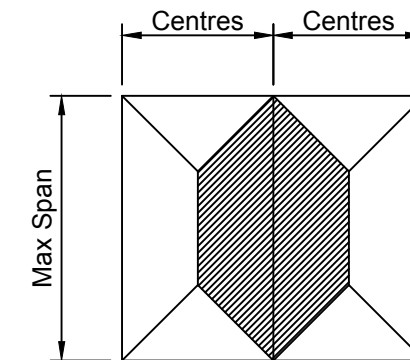
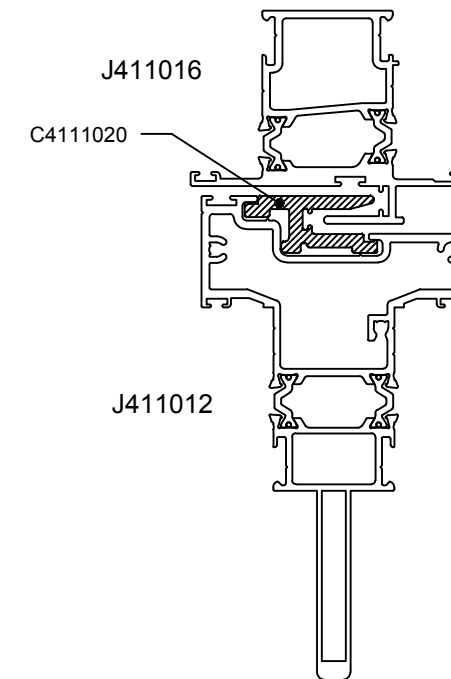

MULLION DATA - Mullion spacing and span calculations are to the current NZS 4211:2008  
Tables shall be used only where no Specific Design wind pressures are specified by the designers. The data provided is given for guidance only and the manufacturer takes no responsibility for incorrect interpretation. It is recommended that a qualified designer be consulted before fabrication.  
SPAN (m) - ULTIMATE (UWP) - SERVICEABILITY (SWP)  
SPAN / DEFLECTION (SPAN / DEF) = RESIDENTIAL 200 min

WIND ZONE :	LOW	MEDIUM	HIGH	VERY HIGH	EXTRA HIGH	
SPAN / DEF. :	200	200	200	200	200	
MULLION LOAD SPACING (m)	0.600	4.280	3.980	3.640	3.420	3.260
	0.800	3.980	3.700	3.400	3.180	3.040
	1.000	3.760	3.500	3.200	3.000	2.820
	1.200	3.600	3.340	3.060	2.840	2.660
	1.400	3.460	3.220	2.940	2.700	2.520
	1.600	3.340	3.120	2.800	2.580	2.420
	1.800	3.260	3.020	2.700	2.480	2.320
	2.000	3.160	2.940	2.600	2.400	2.240
	2.200	3.100	2.840	2.520	2.320	2.180
	2.400	3.020	2.760	2.440	2.240	2.100
2.600	2.960	2.680	2.380	2.180	2.060	

REV#	DESCRIPTION	DATE
A	Tables Updated	28/03/17

### Thermal - Span Charts

SCALE	1:2 @ A3
NAME	
DATE	
DRAWN	T.C 05/2015
CHECKED	M.C 00/2015



DRAWING No.

411.3.1

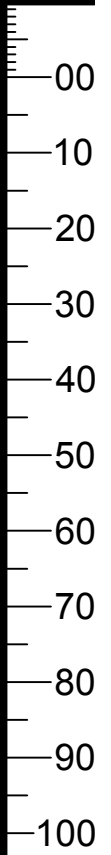

SECTION(S):  
J411016 + J411019

DESCRIPTION:  
SLIDING DOOR STACKER JUNCTION

DATA:  
MOMENT OF INERTIA - 405172 mm<sup>4</sup>

DEFLECTION MAX:  
15mm

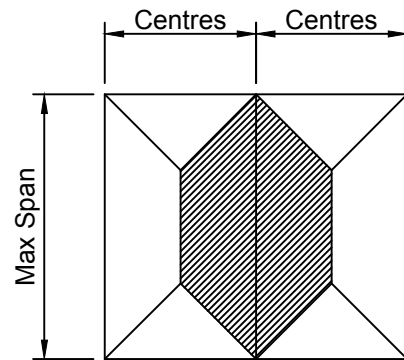
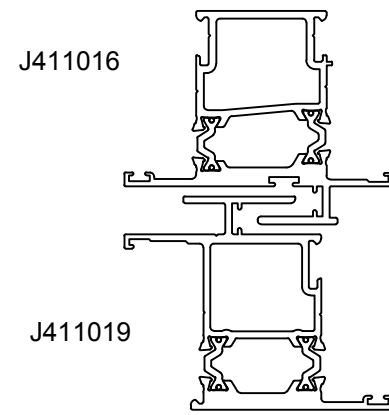

SECTION(S):  
J411016 + J411018

DESCRIPTION:  
SLIDING DOOR BOXED STACKER JUNCTION

DATA:  
MOMENT OF INERTIA - 1299978 mm<sup>4</sup>

DEFLECTION MAX:  
15mm

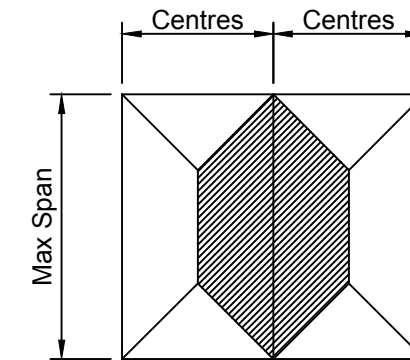
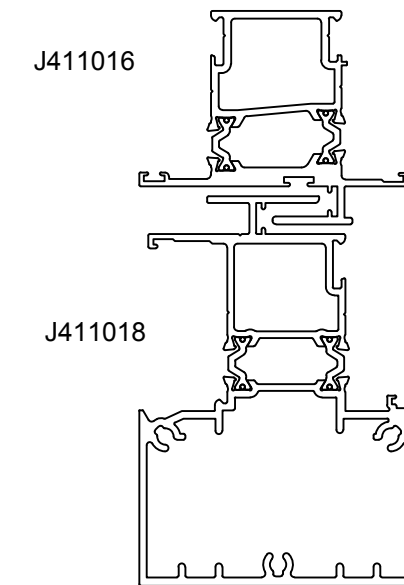

MULLION DATA - Mullion spacing and span calculations are to the current NZS 4211:2008  
Tables shall be used only where no Specific Design wind pressures are specified by the designers. The data provided is given for guidance only and the manufacturer takes no responsibility for incorrect interpretation. It is recommended that a qualified designer be consulted before fabrication.  
SPAN (m) - ULTIMATE (UWP) - SERVICEABILITY (SWP)  
SPAN / DEFLECTION (SPAN / DEF) = RESIDENTIAL 200 min

MULLION DATA - Mullion spacing and span calculations are to the current NZS 4211:2008  
Tables shall be used only where no Specific Design wind pressures are specified by the designers. The data provided is given for guidance only and the manufacturer takes no responsibility for incorrect interpretation. It is recommended that a qualified designer be consulted before fabrication.  
SPAN (m) - ULTIMATE (UWP) - SERVICEABILITY (SWP)  
SPAN / DEFLECTION (SPAN / DEF) = RESIDENTIAL 200 min

WIND ZONE :		LOW	MEDIUM	HIGH	VERY HIGH	EXTRA HIGH
SPAN / DEF. :		200	200	200	200	200
MULLION LOAD SPACING (m)	0.600	3.200	2.960	2.640	2.420	2.260
	0.800	2.960	2.700	2.400	2.200	2.060
	1.000	2.760	2.500	2.220	2.040	1.920
	1.200	2.580	2.360	2.080	1.920	1.800
	1.400	2.460	2.240	1.980	1.820	1.700
	1.600	2.360	2.140	1.900	1.740	1.640
	1.800	2.260	2.060	1.820	1.680	1.560
	2.000	2.180	1.980	1.760	1.620	1.520
	2.200	2.120	1.920	1.700	1.560	1.460
	2.400	2.060	1.860	1.660	1.520	1.420
2.600	2.000	1.820	1.620	1.480	1.380	

WIND ZONE :		LOW	MEDIUM	HIGH	VERY HIGH	EXTRA HIGH
SPAN / DEF. :		200	200	200	200	200
MULLION LOAD SPACING (m)	0.600	4.280	3.980	3.640	3.420	3.260
	0.800	3.980	3.700	3.380	3.180	3.020
	1.000	3.760	3.500	3.200	3.000	2.820
	1.200	3.600	3.340	3.060	2.840	2.660
	1.400	3.460	3.220	2.920	2.680	2.520
	1.600	3.340	3.120	2.800	2.580	2.420
	1.800	3.240	3.020	2.700	2.480	2.320
	2.000	3.160	2.920	2.600	2.380	2.240
	2.200	3.080	2.840	2.520	2.320	2.160
	2.400	3.020	2.760	2.440	2.240	2.100
2.600	2.960	2.680	2.380	2.180	2.060	

REV#	DESCRIPTION	DATE
A	Tables Updated	28/03/17

### Thermal - Span Charts

SCALE	1:2 @ A3
NAME	
DRAWN	T.C 05/2015
CHECKED	M.C 00/2015



DRAWING No.

411.3.2

COPYRIGHT © 2011 MCKECHNIE ALUMINIUM SOLUTIONS LIMITED.  
 PLEASE CHECK THAT ALL DETAILS ARE UP TO DATE BEFORE  
 PROCEEDING. IF IN DOUBT ASK.

411 Thermal Sliding Door

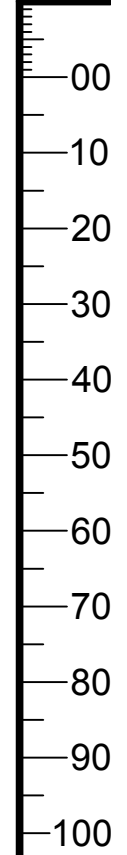

SECTION(S):  
J411037 + J411035

DESCRIPTION:  
SLIDING DOOR 4PJ JUNCTION

DATA:  
MOMENT OF INERTIA - 450938 mm<sup>4</sup>

DEFLECTION MAX:  
15mm

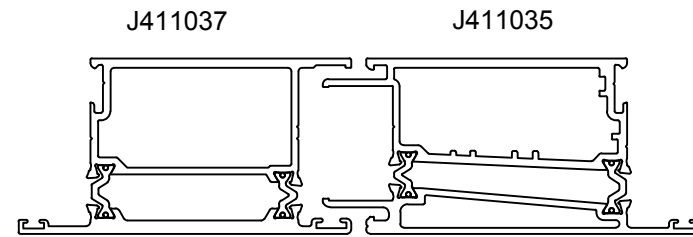

SECTION(S):  
J411037 + J411036

DESCRIPTION:  
SLIDING DOOR BOXED 4PJ JUNCTION

DATA:  
MOMENT OF INERTIA - 1419595 mm<sup>4</sup>

DEFLECTION MAX:  
15mm

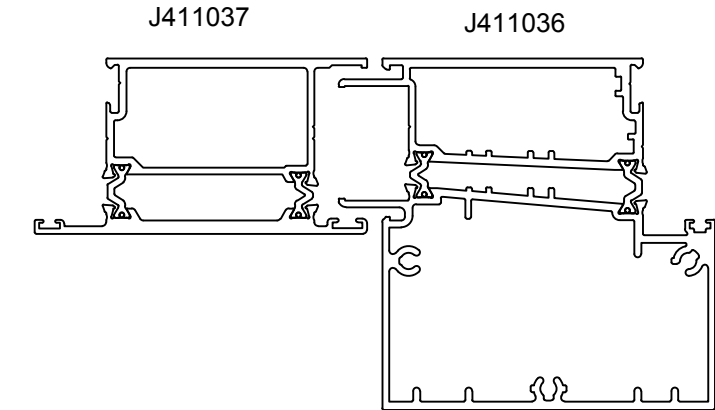

MULLION DATA - Mullion spacing and span calculations are to the current NZS 4211:2008  
Tables shall be used only where no Specific Design wind pressures are specified by the designers. The data provided is given for guidance only and the manufacturer takes no responsibility for incorrect interpretation. It is recommended that a qualified designer be consulted before fabrication.  
SPAN (m) - ULTIMATE (UWP) - SERVICEABILITY (SWP)  
SPAN / DEFLECTION (SPAN / DEF) = RESIDENTIAL 200 min

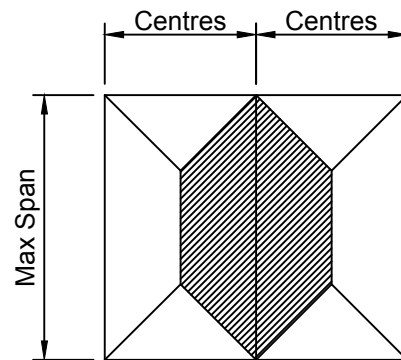

MULLION DATA - Mullion spacing and span calculations are to the current NZS 4211:2008  
Tables shall be used only where no Specific Design wind pressures are specified by the designers. The data provided is given for guidance only and the manufacturer takes no responsibility for incorrect interpretation. It is recommended that a qualified designer be consulted before fabrication.  
SPAN (m) - ULTIMATE (UWP) - SERVICEABILITY (SWP)  
SPAN / DEFLECTION (SPAN / DEF) = RESIDENTIAL 200 min

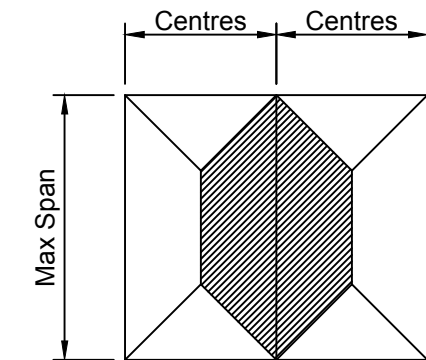

WIND ZONE :		LOW	MEDIUM	HIGH	VERY HIGH	EXTRA HIGH
SPAN / DEF. :		200	200	200	200	200
MULLION LOAD SPACING (m)	0.600	3.280	3.060	2.720	2.500	2.340
	0.800	3.060	2.800	2.480	2.280	2.140
	1.000	2.860	2.580	2.300	2.120	1.980
	1.200	2.680	2.440	2.160	1.980	1.860
	1.400	2.540	2.320	2.060	1.880	1.760
	1.600	2.440	2.220	1.960	1.800	1.700
	1.800	2.340	2.120	1.880	1.740	1.620
	2.000	2.260	2.060	1.820	1.680	1.560
	2.200	2.200	1.980	1.760	1.620	1.520
	2.400	2.120	1.940	1.720	1.580	1.480
2.600	2.080	1.880	1.660	1.540	1.440	

WIND ZONE :		LOW	MEDIUM	HIGH	VERY HIGH	EXTRA HIGH
SPAN / DEF. :		200	200	200	200	200
MULLION LOAD SPACING (m)	0.600	4.380	4.060	3.720	3.500	3.320
	0.800	4.060	3.780	3.460	3.240	3.100
	1.000	3.840	3.580	3.280	3.080	2.900
	1.200	3.680	3.420	3.120	2.920	2.740
	1.400	3.540	3.280	3.000	2.780	2.600
	1.600	3.420	3.180	2.880	2.640	2.480
	1.800	3.320	3.080	2.780	2.540	2.380
	2.000	3.240	3.000	2.680	2.460	2.300
	2.200	3.160	2.920	2.600	2.380	2.240
	2.400	3.080	2.840	2.520	2.320	2.160
2.600	3.020	2.760	2.460	2.260	2.120	

REV#	DESCRIPTION	DATE
A	Tables Updated	28/03/17

### Thermal - Span Charts

SCALE	1:2 @ A3
NAME	
DRAWN	T.C 05/2015
CHECKED	M.C 00/2015



DRAWING No. 411.3.3

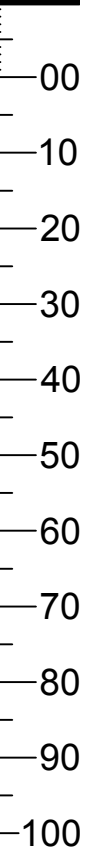

SECTION(S):  
J411009 + J411013

DESCRIPTION:  
SLIDING DOOR 3PJ

DATA:  
MOMENT OF INERTIA - 1954821 mm<sup>4</sup>

DEFLECTION MAX:  
15mm

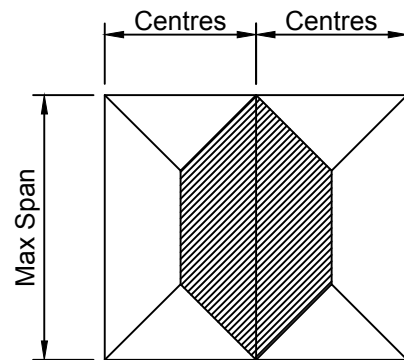
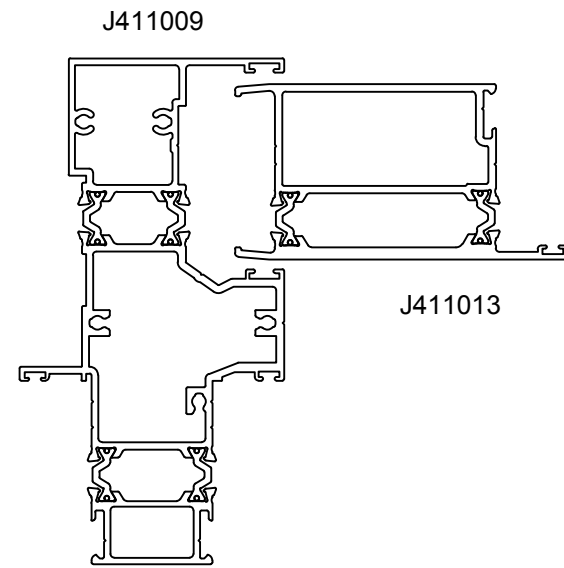

SECTION(S):  
J411011 + J411013

DESCRIPTION:  
SLIDING DOOR 3PJ STACKER

DATA:  
MOMENT OF INERTIA - 5191148 mm<sup>4</sup>

DEFLECTION MAX:  
15mm

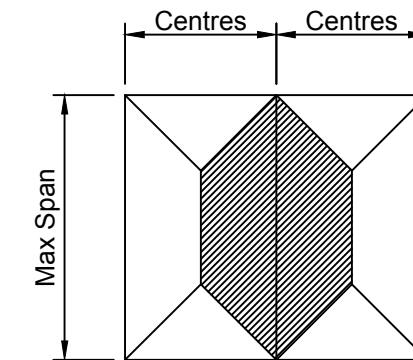
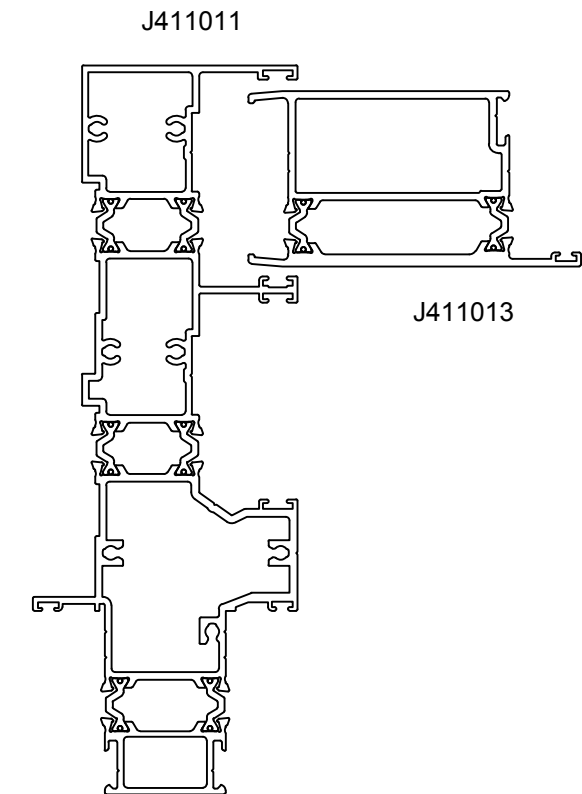

MULLION DATA - Mullion spacing and span calculations are to the current NZS 4211:2008  
Tables shall be used only where no Specific Design wind pressures are specified by the designers. The data provided is given for guidance only and the manufacturer takes no responsibility for incorrect interpretation. It is recommended that a qualified designer be consulted before fabrication.  
SPAN (m) - ULTIMATE (UWP) - SERVICEABILITY (SWP)  
SPAN / DEFLECTION (SPAN / DEF) = RESIDENTIAL 200 min

MULLION DATA - Mullion spacing and span calculations are to the current NZS 4211:2008  
Tables shall be used only where no Specific Design wind pressures are specified by the designers. The data provided is given for guidance only and the manufacturer takes no responsibility for incorrect interpretation. It is recommended that a qualified designer be consulted before fabrication.  
SPAN (m) - ULTIMATE (UWP) - SERVICEABILITY (SWP)  
SPAN / DEFLECTION (SPAN / DEF) = RESIDENTIAL 200 min

WIND ZONE :		LOW	MEDIUM	HIGH	VERY HIGH	EXTRA HIGH
SPAN / DEF. :		200	200	200	200	200
MULLION LOAD SPACING (m)	0.600	4.740	4.400	4.040	3.780	3.600
	0.800	4.400	4.100	3.760	3.520	3.360
	1.000	4.160	3.880	3.540	3.320	3.180
	1.200	3.980	3.700	3.380	3.180	3.040
	1.400	3.840	3.560	3.260	3.060	2.900
	1.600	3.700	3.440	3.160	2.940	2.760
	1.800	3.600	3.340	3.060	2.840	2.660
	2.000	3.500	3.260	2.980	2.740	2.560
	2.200	3.420	3.180	2.880	2.660	2.480
	2.400	3.340	3.120	2.800	2.580	2.420
2.600	3.280	3.060	2.720	2.500	2.360	

WIND ZONE :		LOW	MEDIUM	HIGH	VERY HIGH	EXTRA HIGH
SPAN / DEF. :		200	200	200	200	200
MULLION LOAD SPACING (m)	0.600	6.040	5.620	5.160	4.840	4.600
	0.800	5.620	5.240	4.800	4.500	4.280
	1.000	5.320	4.960	4.540	4.260	4.060
	1.200	5.080	4.740	4.320	4.060	3.880
	1.400	4.900	4.560	4.160	3.900	3.720
	1.600	4.740	4.400	4.020	3.780	3.600
	1.800	4.600	4.280	3.920	3.660	3.500
	2.000	4.480	4.160	3.800	3.580	3.400
	2.200	4.360	4.060	3.720	3.480	3.320
	2.400	4.280	3.980	3.640	3.420	3.260
2.600	4.200	3.900	3.560	3.340	3.180	

REV#	DESCRIPTION	DATE
A	Tables Updated	28/03/17

### Thermal - Span Charts

SCALE	1:2 @ A3
NAME	
DATE	
DRAWN	T.C 05/2015
CHECKED	M.C 00/2015



DRAWING No.

411.3.4

411 Thermal Sliding Door

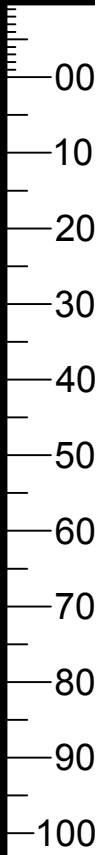

COPYRIGHT © 2011 MCKECHNIE ALUMINIUM SOLUTIONS LIMITED. PLEASE CHECK THAT ALL DETAILS ARE UP TO DATE BEFORE PROCEEDING. IF IN DOUBT ASK. A3 ORIGINAL SIZE.



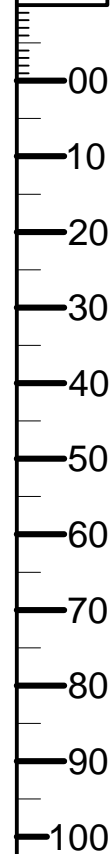

# 413

# Thermal

# Bi Fold

# Span Charts

REV#	DESCRIPTION	DATE
-	-	00/2013
-	-	00/2013
-	-	00/2013
-	-	00/00/2013

SPAN CHART

SCALE	NTS	
	NAME	DATE
DRAWN	ADM	05/10/17
CHECKED		



DRAWING No. 300 SERIES SP

SECTION(S):  
J409024 + J409024

DESCRIPTION:  
FRENCH DOOR

DATA:  
MOMENT OF INERTIA - 565182 mm<sup>4</sup>

DEFLECTION MAX:  
15mm

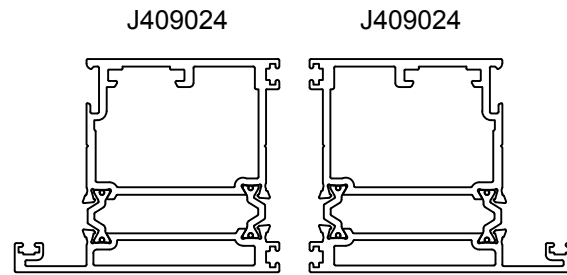

SECTION(S):  
J409016 + J409015

DESCRIPTION:  
FRENCH DOOR

DATA:  
MOMENT OF INERTIA - 715279 mm<sup>4</sup>

DEFLECTION MAX:  
15mm

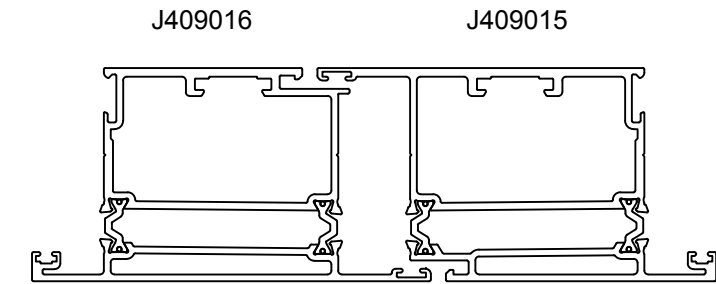

MULLION DATA - Mullion spacing and span calculations are to the current NZS 4211:2008  
Tables shall be used only where no Specific Design wind pressures are specified by the designers. The data provided is given for guidance only and the manufacturer takes no responsibility for incorrect interpretation. It is recommended that a qualified designer be consulted before fabrication.  
SPAN (m) - ULTIMATE (UWP) - SERVICEABILITY (SWP)  
SPAN / DEFLECTION (SPAN / DEF) = RESIDENTIAL 200 min

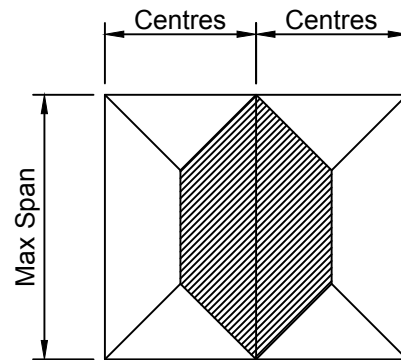

MULLION DATA - Mullion spacing and span calculations are to the current NZS 4211:2008  
Tables shall be used only where no Specific Design wind pressures are specified by the designers. The data provided is given for guidance only and the manufacturer takes no responsibility for incorrect interpretation. It is recommended that a qualified designer be consulted before fabrication.  
SPAN (m) - ULTIMATE (UWP) - SERVICEABILITY (SWP)  
SPAN / DEFLECTION (SPAN / DEF) = RESIDENTIAL 200 min

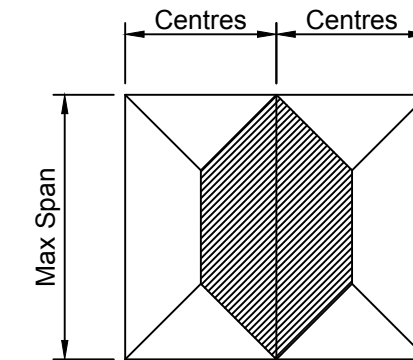

WIND ZONE :	LOW	MEDIUM	HIGH	VERY HIGH	EXTRA HIGH	
SPAN / DEF. :	200	200	200	200	200	
MULLION LOAD SPACING (m)	0.600	3.480	3.220	2.940	2.700	2.540
	0.800	3.220	3.000	2.680	2.460	2.300
	1.000	3.060	2.800	2.480	2.280	2.140
	1.200	2.900	2.620	2.340	2.140	2.000
	1.400	2.740	2.500	2.220	2.040	1.900
	1.600	2.620	2.380	2.120	1.940	1.820
	1.800	2.520	2.300	2.040	1.880	1.760
	2.000	2.440	2.220	1.960	1.800	1.700
	2.200	2.360	2.140	1.900	1.740	1.640
	2.400	2.300	2.080	1.840	1.700	1.600
2.600	2.240	2.020	1.800	1.660	1.560	

WIND ZONE :	LOW	MEDIUM	HIGH	VERY HIGH	EXTRA HIGH	
SPAN / DEF. :	200	200	200	200	200	
MULLION LOAD SPACING (m)	0.600	3.680	3.420	3.140	2.920	2.740
	0.800	3.420	3.180	2.900	2.660	2.500
	1.000	3.240	3.020	2.680	2.460	2.320
	1.200	3.100	2.840	2.520	2.320	2.180
	1.400	2.980	2.700	2.400	2.200	2.060
	1.600	2.840	2.580	2.300	2.100	1.980
	1.800	2.740	2.480	2.200	2.020	1.900
	2.000	2.640	2.400	2.120	1.960	1.840
	2.200	2.560	2.320	2.060	1.900	1.780
	2.400	2.480	2.260	2.000	1.840	1.720
2.600	2.420	2.200	1.940	1.780	1.680	

REV#	DESCRIPTION	DATE

### Thermal - Span Charts

SCALE	1:2 @ A3
NAME	
DRAWN	T.C 05/2015
CHECKED	M.C 00/2015



DRAWING No.

413.3.1

Thermal Bifold Door

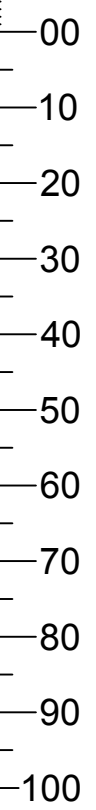

COPYRIGHT © 2011 MCKECHNIE ALUMINIUM SOLUTIONS LIMITED.  
PLEASE CHECK THAT ALL DETAILS ARE UP TO DATE BEFORE  
PROCEEDING. IF IN DOUBT ASK.