

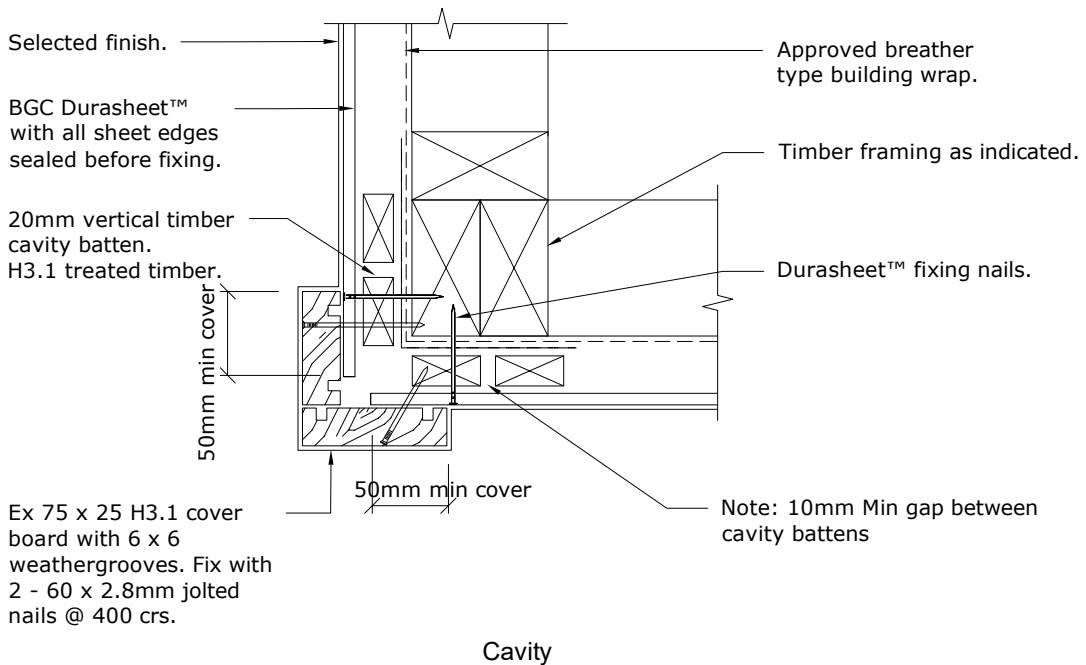

# Fibre Cement

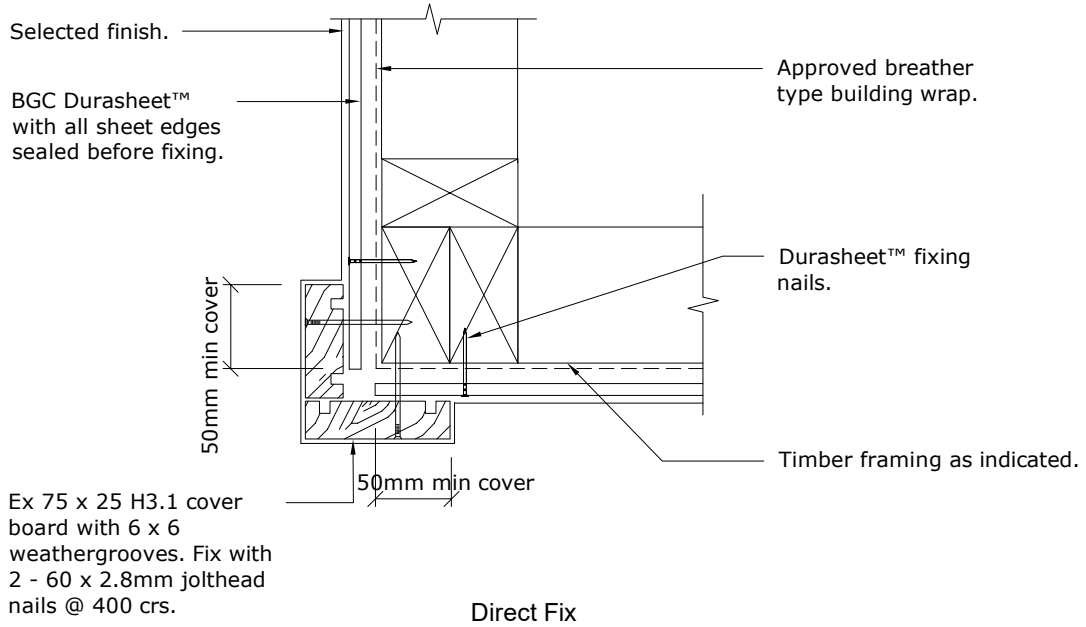

PROFILE **BGC Durasheet™**

DETAIL **Timber Batten External Corner Joints**

DATE **Aug 2021**

SCALE **1:5 @ A4**

DETAIL NO. **D 11**