



Multi-Unit Residential

Inter-Tenancy Wall and Floor/Ceiling Systems and their Junctions

The last few years has seen a rise in light timber and steel framed multi-unit residential design and construction, and with it comes the challenge of satisfying inter-tenancy (IT) noise control, fire resistance, and structural performance.

In a previous article¹ we talked about central barrier systems and conventional double frame systems, their benefits and scope of application. The article pointed out that central barrier systems are ideally suited for terraced housing but might not be cost-effective for multi-level apartment construction. This current article concentrates on low-rise timber framed multi-level residential construction and associated wall-to-ceiling junctions.

Fire design strategy

In the case of a fire, the NZBC requires us to safeguard occupants and provide adjacent property protection. Life safety requirements aim to provide occupants of adjacent apartments with warning and enough time to evacuate. Property protection aims to shield adjacent units, accepting that water damage following fire-fighting operations and subsequent repair of boundary structures in common ownership, may be inevitable.

Although the NZBC aims to protect adjacent property, it does not set out to protect the property experiencing a fire. This means that a lower apartment can sustain significant damage during a fire, provided structural support to the units above is maintained. One design strategy might be to accept the need to replace lower loadbearing members, whilst another strategy might seek to limit post-fire repairs by fully protecting the lower loadbearing structure from the effects of a design fire.

The selection of protective linings depends on the fire design strategy, acoustic requirements, as well as the preferred method of construction.

¹ GIB® *Inter-Tenancy Barrier Systems - Horses for Courses*, 2020. URL: <https://www.gib.co.nz/gib-news/articles/gib-inter-tenancy-barrier-systems-horses-for-courses/>

Designing for noise control

Consideration needs to be given to acoustic comfort and the potential transmission of noise between apartments. NZBC Clause G6 requires Sound Transmission Class (STC) 55 for airborne noise transmission through walls and floors, and Impact Insulation Class (IIC 55) for impact noise transmission

through floors. These are laboratory measurements and 5 dB reductions are commonly accepted on site. Performance levels exceeding the minimum NZBC requirements increase occupant satisfaction.

Structural connections can create noise flanking paths, and these can significantly reduce on-site performance. Careful detailing can minimise losses.

IT Wall construction

In timber framed multi-unit and multi-level construction, lower loadbearing walls require protective linings. The most common solution is a traditional IT wall configuration, such as a double frame system as shown in Figure 1. Service penetrations are fire-stopped where they pass through the linings.

Performance linings, combined with framing isolation and fibrous cavity insulation, deliver the mass required to reduce noise transmission. Lining options are available to meet or exceed NZBC requirements for fire-resistance and noise control.

IT Floor/ceiling construction

Like vertical IT walls, horizontal IT separations are required to achieve noise control and fire separation between different levels in an apartment building. When using light timber framed construction, these separations commonly consist of sheet flooring on floor framing, fibrous cavity insulation, and a resiliently suspended ceiling with two layers of performance plasterboard. Figure 2 depicts a typical example of an IT floor/ceiling specification.

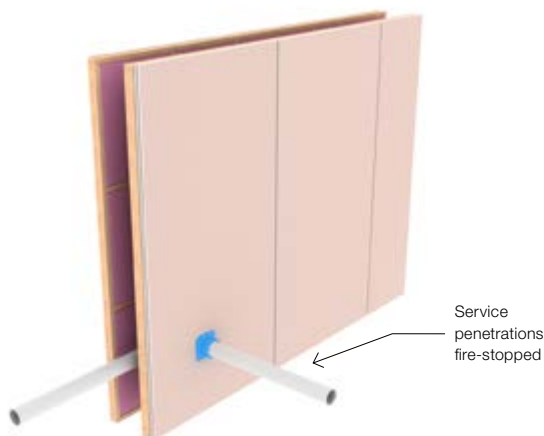

FIGURE 1: Double timber frame IT wall system

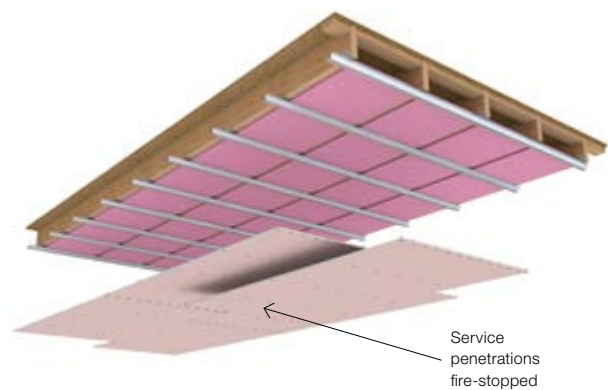

FIGURE 2: Typical IT floor/ceiling system

IT Wall and floor/ceiling junctions

Units are effectively separated from each other and from common areas by wall and floor/ceiling specifications forming the apartment’s fire and noise control cocoon.

Figure 3 illustrates a junction where IT wall and floor/ceiling systems meet, separating four apartment units.

All service penetrations through the wall and ceiling linings must be fire-stopped to ensure fire is contained within an affected apartment. The mass of the ceiling linings and lower apartment wall linings also assists with achieving required noise attenuation between levels and minimising potential impact and airborne noise ‘flanking’ via the structure.

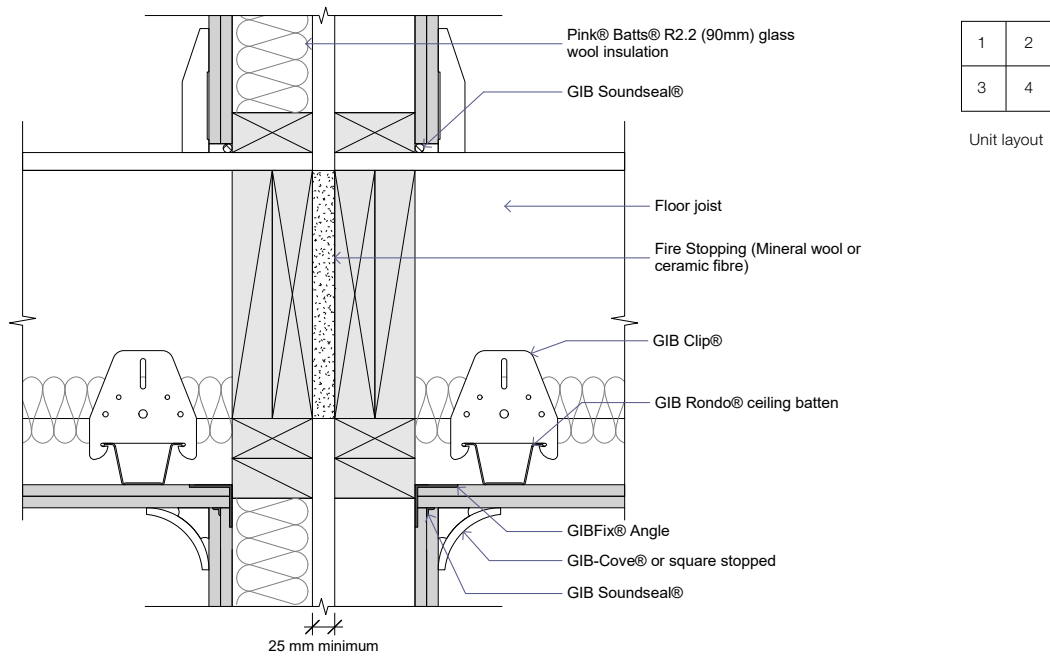

FIGURE 3: Typical IT double timber frame wall and floor/ceiling junction

Apartment walls

Conventional house framing techniques might not always work when constructing partitions within multi-level and multi-unit apartments.

When using conventional framing techniques, by erecting all loadbearing and non-loadbearing frames up to the underside of the floor joists above, the protective envelope is breached in many places. This will increase the risk of noise flanking through structural connections and requires careful detailing to maintain fire resistance.

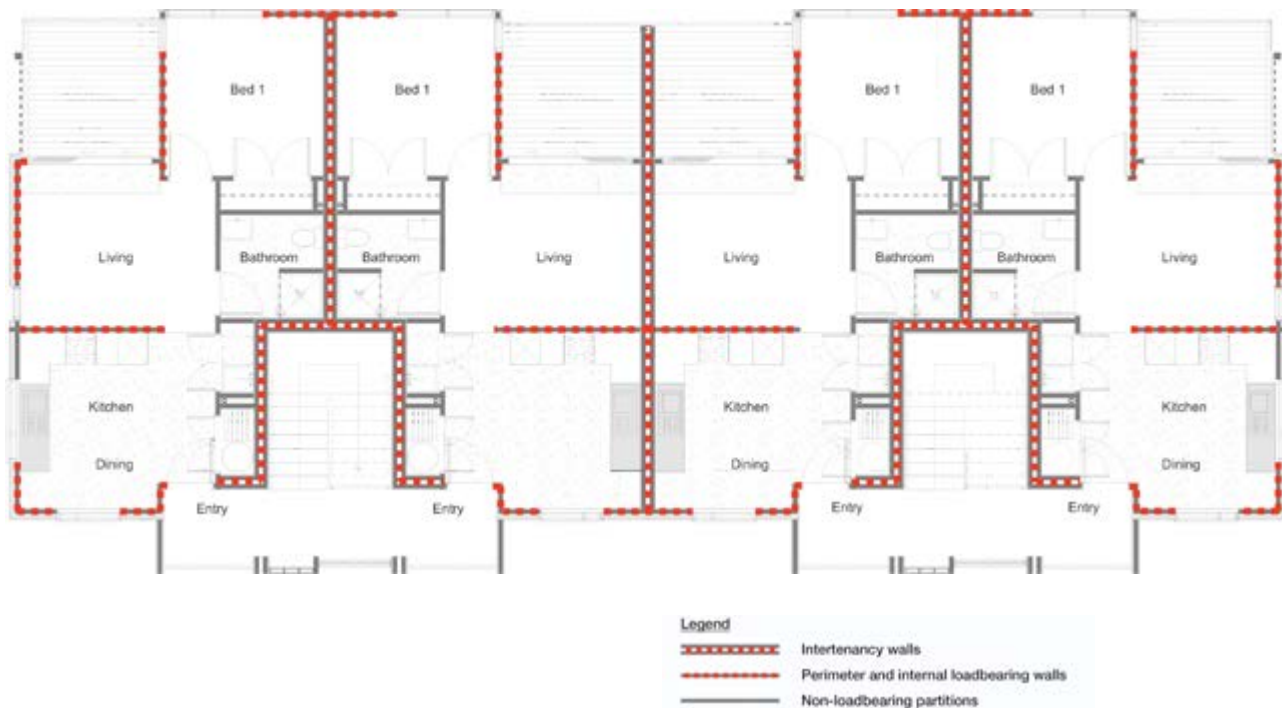

FIGURE 4: Apartment layout showing perimeter and internal loadbearing walls, and non-loadbearing partitions

Loadbearing apartments walls

Loadbearing walls often include apartment perimeter frames and any internal walls providing support to a higher floor, as illustrated in Figure 4.

Apartment IT walls are commonly constructed using double stud frames lined with two layers of performance plasterboard. These walls are often loadbearing and structurally connected to the floor above. The lining mass will minimise noise flanking. Construction is simplified by specifying the same linings for the ceiling and walls. Figure 5 illustrates the use of floor/ceiling specification GBDFA 60b and IT wall specification GBTLA 90c.

Internal loadbearing walls, located entirely within the apartment, can be exposed to fire from both sides simultaneously. Appropriate linings will need to ensure that structural adequacy is maintained in a fire. As for IT walls, the mass of these linings will minimise noise flanking and construction is simplified by keeping wall and ceiling linings the same. Figure 6 illustrates floor/ceiling specification GBDFA 60b and wall lining specification GBUW 60 both sides of an internal loadbearing wall.

In both cases service penetrations are fire-stopped where they pass through the wall linings.

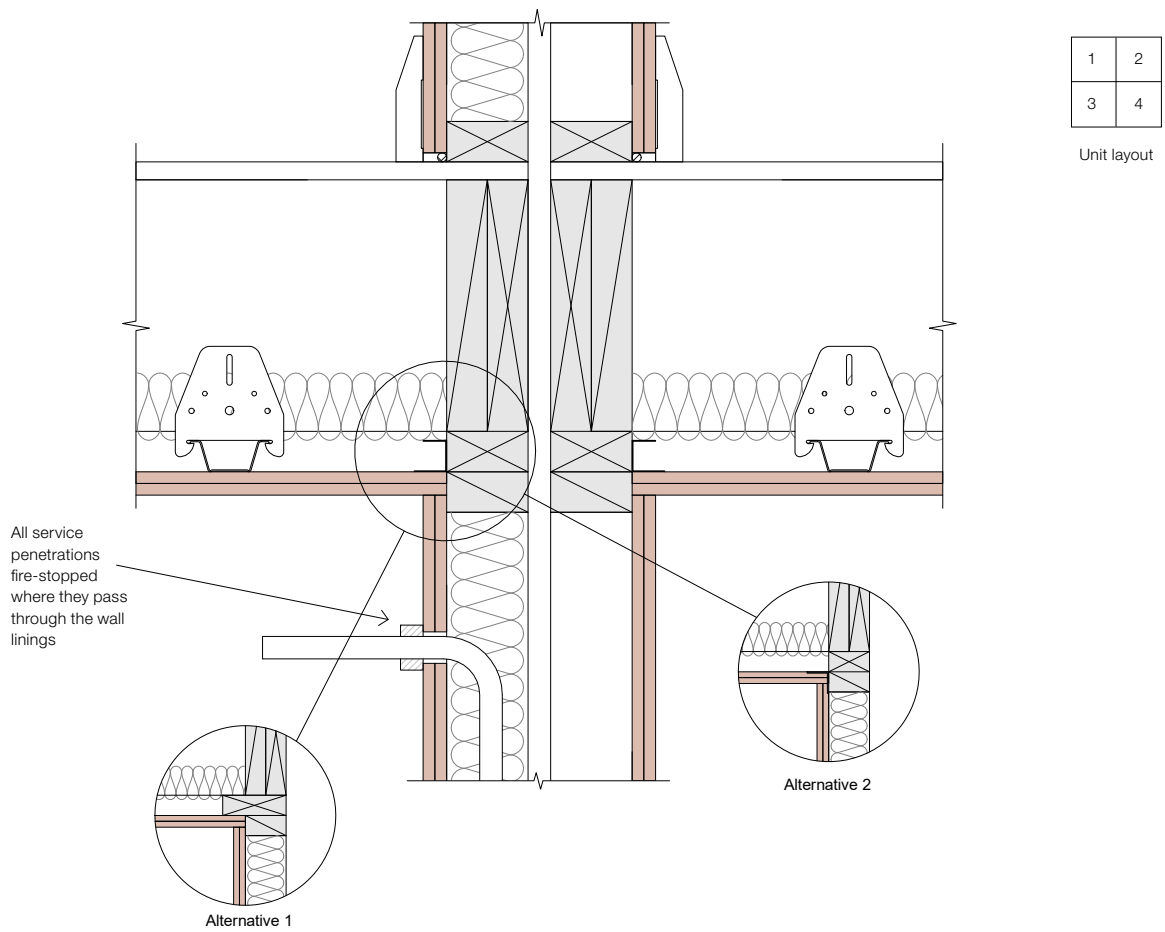

FIGURE 5: LB IT Wall

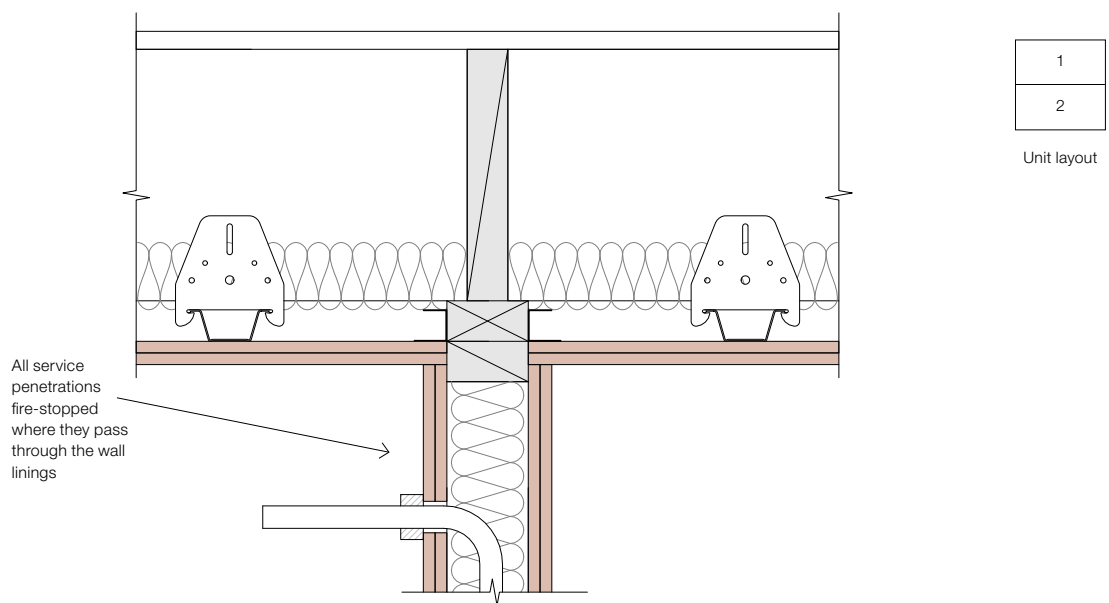

FIGURE 6: LB Internal Wall

External loadbearing walls can be constructed as illustrated in Figure 7 and lined in accordance with a GBUW 60 specification if the design strategy aims to minimise damage to wall framing. Alternatively, a selection of tested external loadbearing wall systems is

available from sheet material suppliers. For multi-level structures it pays to check that fire design loads can be supported. The potential for noise flanking might also be a consideration. Services are fire-stopped where they penetrate the fire-rated wall linings.

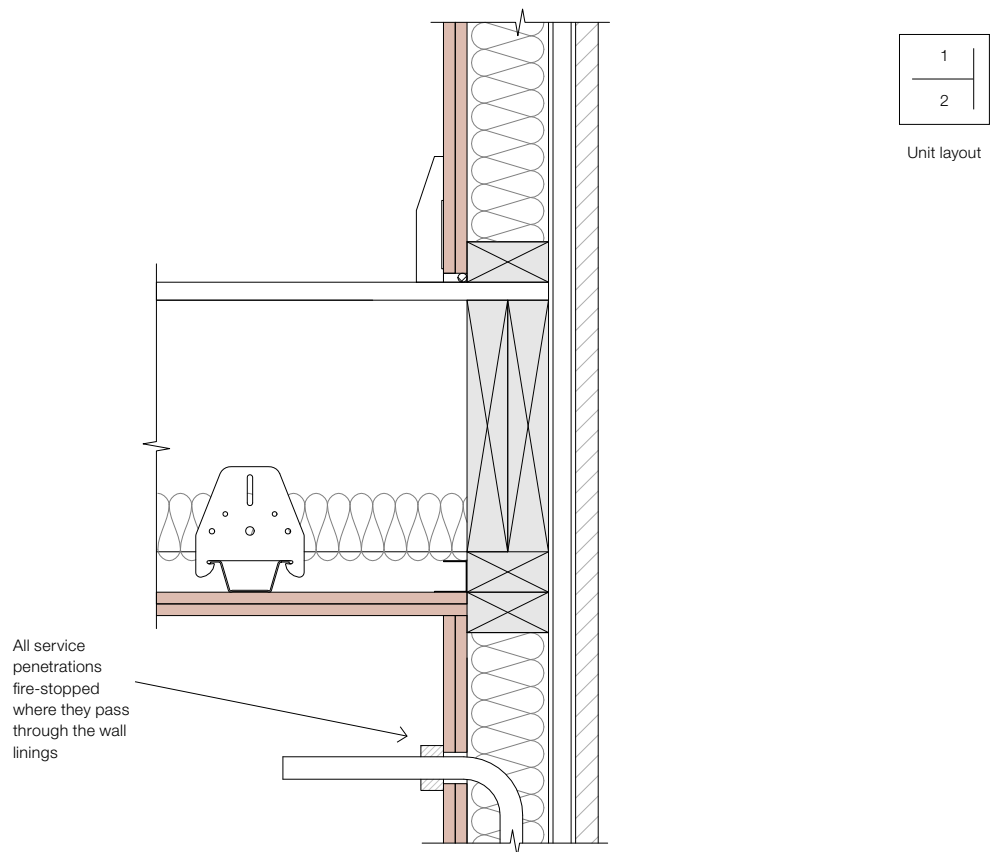

FIGURE 7: LB External Wall

Non-loadbearing walls within apartments

Non-loadbearing walls do not carry gravity loads of the structure above. They include partitions dividing the apartment into living rooms, bedrooms, service rooms, etc. If these partitions are installed with conventional linings, not designed to meet fire or noise control requirements, then penetrations through the ceiling envelope will constitute a potential path for fire spread (white arrow) and noise flanking (black arrow), as illustrated in Figure 8.

A much-preferred option is to complete the fire and noise control envelope first by erecting and lining any loadbearing walls, IT walls and ceilings. Then use commercial fit-out techniques to install internal non-loadbearing partitions by friction fitting metal or timber studs into steel top and bottom tracks as illustrated in Figure 9. Any service penetrations are sealed where they pass through the top track and ceiling linings.

Alternatively, non-loadbearing internal walls can be constructed as outlined under 'non-loadbearing partitions and bracing walls' below.

NLB INTERNAL WALLS MET IT FLOORS

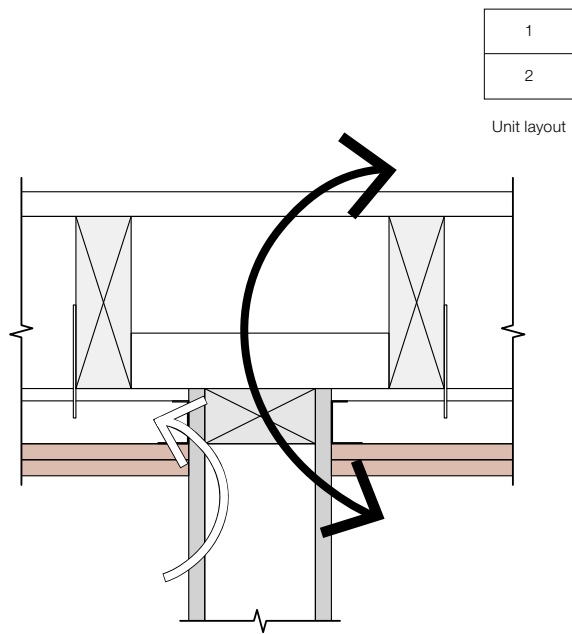

FIGURE 8: Partitions Penetrating the Ceiling
Potential for fire spread (white arrow)
Potential for noise flanking (black arrow)

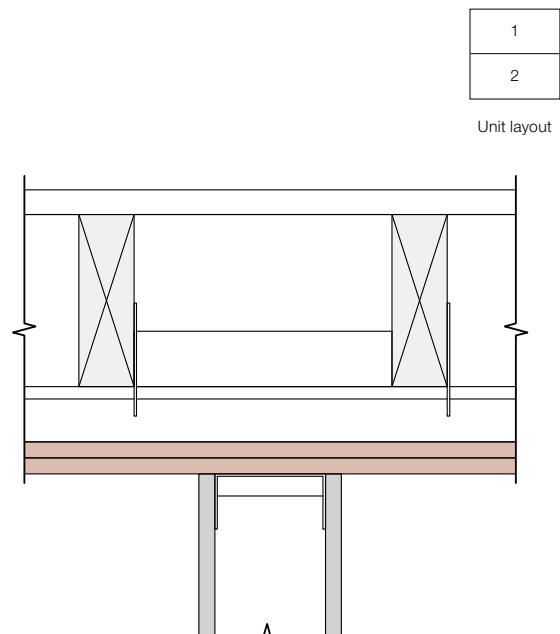

FIGURE 9: Partitions below the Ceiling
Apartment fitout after installing the key noise and fire-rated elements

Non-loadbearing partitions and bracing walls

Figure 10 shows examples of lower unit partitions and bracing walls. Figure 11 shows a partition wall and lowered ceiling. These walls are not designed to support gravity loads but can provide lateral bracing resistance. The walls have single linings each side and a floating floor system is shown to minimise effects of noise flanking through structural connections.

Where non-loadbearing partitions penetrate the ceiling linings, ensure that appropriate wall linings are selected. The partition specification must have an FRR no more than 30 minutes less than the floor/ceiling system. E.g., when the floor/ceiling system requires a 60-minute FRR,

the partition must be constructed in accordance with the requirements for a 30-minute FRR, using additional perimeter fasteners to meet bracing requirements as appropriate.

As illustrated in Figure 12 penetration seals are installed where services pass through the top plate. Follow the instructions provided by the penetration seal supplier. Service holes are drilled centrally through the timber top plates leaving a minimum 20 mm of timber each side.

Unless fire-stopped, no wall lining service penetrations are permitted above the highest nog. Below this level wall lining penetrations do not need to be fire-stopped.

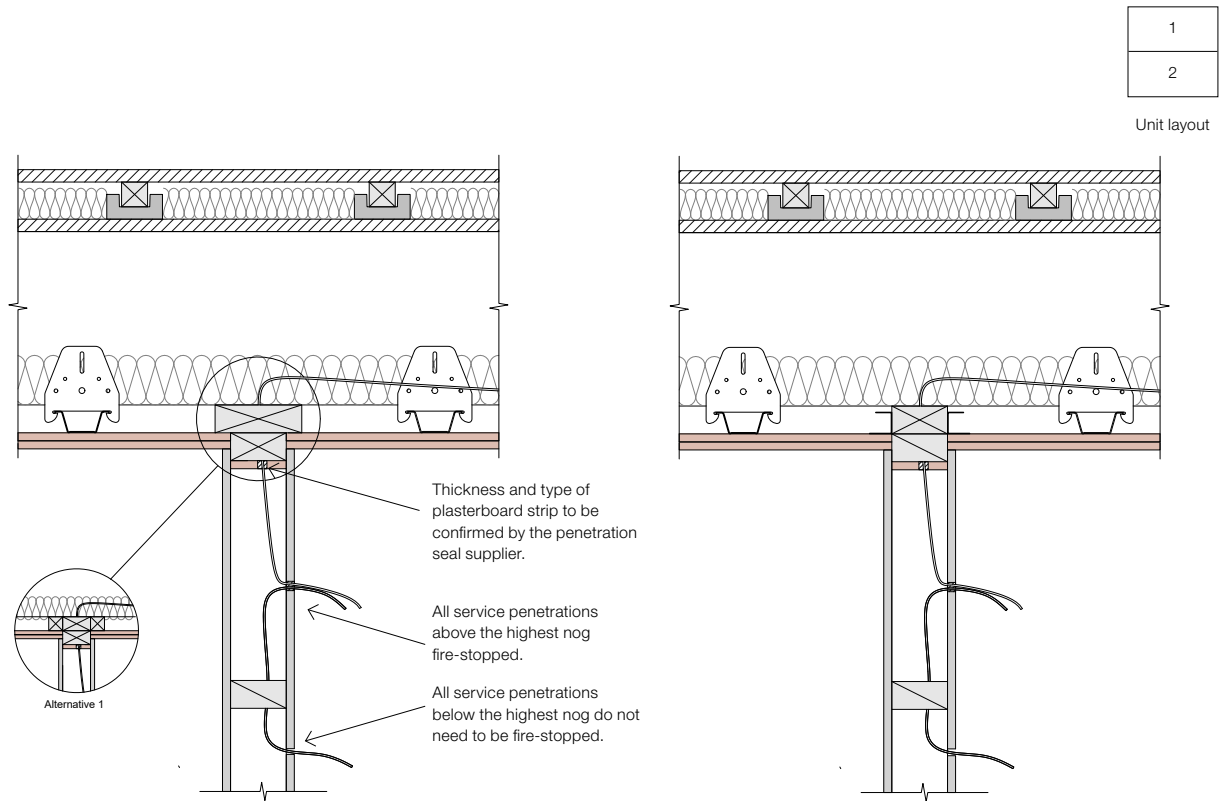

FIGURE 10: NLB Internal Partition or Bracing Wall penetrating the Ceiling
 Linings both sides, installed in accordance with an FRR no more than 30 minutes less than the floor/ceiling
 Services fire-stopped using suitable proprietary systems installed below the double top plate
 Floating floor to mitigate noise flanking

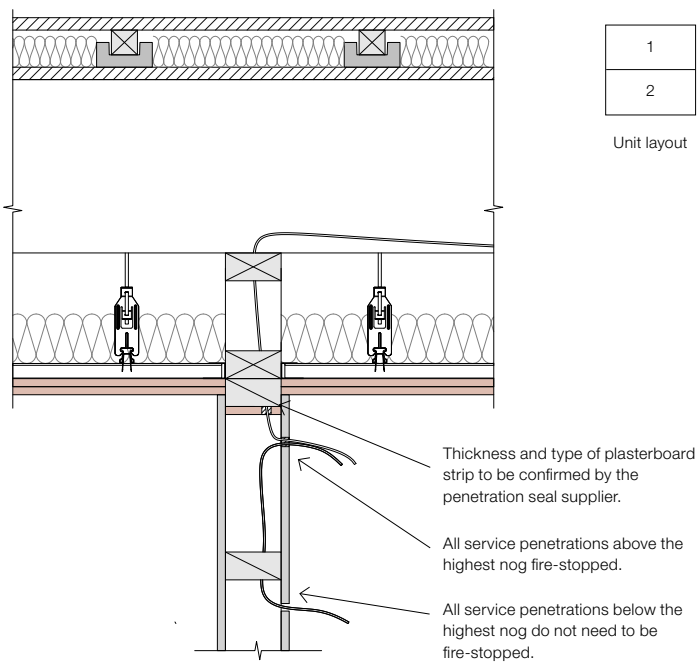

FIGURE 11: Lowered ceiling with timber top plate



FIGURE 12: Proprietary Penetration Seals where Services pass through the Top Plate
Examples of services fire-stopped using tested systems installed below the double top plate

In summary

Carefully consider what IT system best suits your needs. Central IT barrier systems are ideal for Terrace Home applications, whilst traditional double frame systems might be the better option in framed multi-level apartment construction.

Using conventional house framing methods in multi-level construction can result in breaching the apartment’s protective envelope in many places. This requires complex detailing to ensure fire integrity and noise control are maintained. Consider installation of non-loadbearing partitions below the ceiling using commercial fitout techniques.

Where loadbearing partitions penetrate the ceiling linings, select appropriate wall linings. Using the same number and type as the ceiling linings can minimise the risk of fire or noise flanking. When single linings are selected potential noise flanking might require a floating floor system. Fire penetration seals are installed where services pass through the wall linings.

Where non-loadbearing partitions penetrate the ceiling linings, select an appropriate wall specification with an FRR no more than 30 minutes less than the floor/ceiling system. Potential for noise flanking is likely to require a floating floor system. Fire penetration seals are installed where services pass through the top plate. Service penetrations through wall linings can be left unsealed when formed below the highest nog in the wall framing.

Sources for further information include:

GIB® Intertenancy Barrier Systems for Terrace Homes 2016
gib.co.nz/systems/gib-intertenancy-barrier-systems-for-terrace-homes/

GIB® Noise Control Systems, 2017
gib.co.nz/systems/gib-noise-control-systems/

GIB® Fire Rated Systems, 2018
gib.co.nz/systems/gib-fire-rated-systems/

New Zealand Wood Design Guides
<https://www.wpma.org.nz/timber-design-guides.html>