

185mm ON GABLE & EAVE TO SUIT CONCRETE TILE ROOF

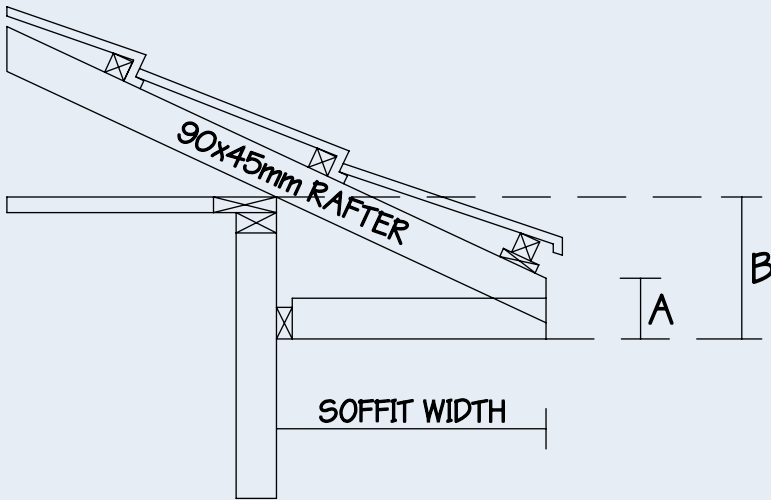

Eaves Detail

NOTES

- A 25mm packer is required for the bottom concrete tile batten.
- Dimension 'A' is the height from the top of the rafter to the bottom of the soffit bearer.
- 50x50 batten.

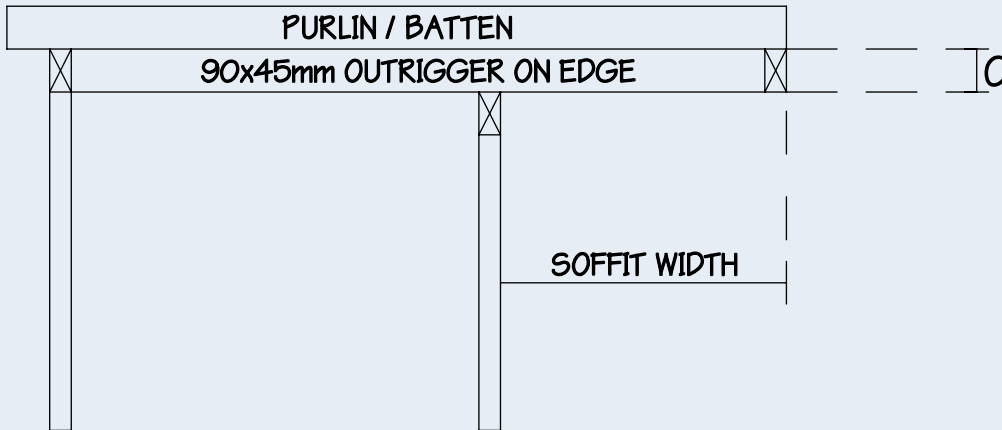

Gable End Detail

NOTES

- Barge tiles required on gables.

GENERAL NOTES

- Please inform your precutter which Metalcraft external fascia system you have selected.
- For best results, scaffolding must be supplied by the customer to:
 - extend at least 500mm past external/gable corners
 - be approximately 1700mm below the rafter end in height
 - meet OSH-approved safety standards
- Metalcraft external rainwater products must be washed regularly to ensure maximum longevity. Areas that do not get regular washing by rain may require special attention.
- For roof pitch less than 20° consult your nearest Metalcraft branch.

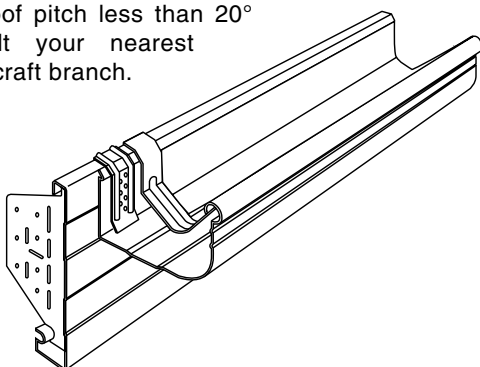

PITCH	TOE CUT (A)	TOP CHORD DROP (C)	SOFFIT DROP (B)		
			450 O/H	600 O/H	750 O/H
20	96mm	90mm	164mm	218mm	273mm
22.5	97mm	90mm	186mm	249mm	311mm
25	99mm	90mm	210mm	280mm	350mm
27.5	101mm	90mm	234mm	312mm	390mm
30	104mm	90mm	260mm	346mm	433mm
32.5	107mm	90mm	287mm	382mm	478mm
35	110mm	90mm	315mm	420mm	525mm
37.5	113mm	90mm	345mm	460mm	575mm
40	117mm	90mm	378mm	503mm	629mm

185mm ON GABLE & EAVE TO SUIT METAL ROOF

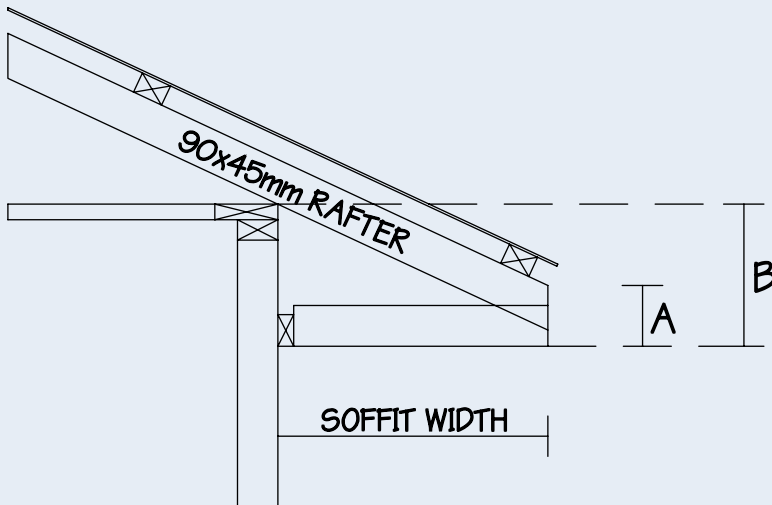

Eaves Detail

NOTES

- 50x50 batten required for metal tile.
- 70x45 purlin for longrun.

Gable End Detail

NOTES

- Gable flashing required.

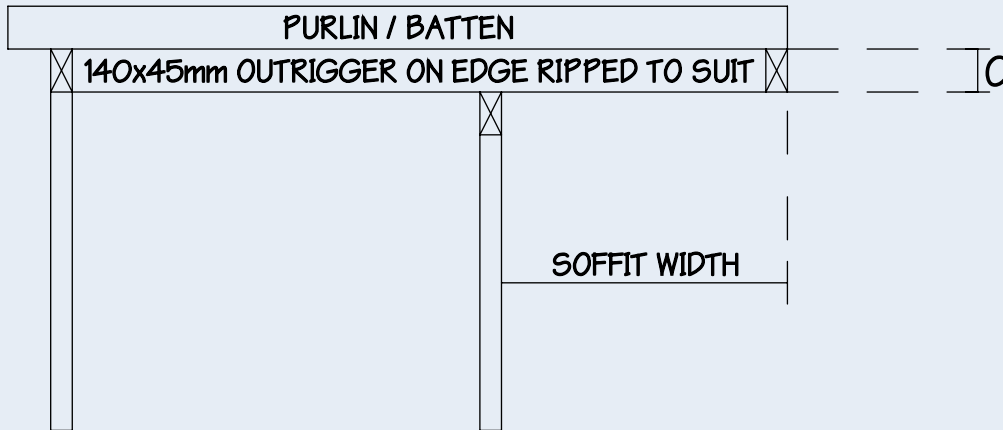

GENERAL NOTES

- Please inform your precutter which Metalcraft external fascia system you have selected.
- Prior to installation, scaffolding must be supplied by the customer to:
 - extend at least 500mm past external/gable corners
 - be approximately 1700mm below the rafter end in height
 - meet OSH-approved safety standards
- Metalcraft external rainwater products must be washed regularly to ensure maximum longevity. Areas that do not get regular washing by rain may require special attention.

PITCH	TOE CUT (A)	TOP CHORD DROP (C)	SOFFIT DROP (B)		
			450 O/H	600 O/H	750 O/H
10	127mm	125mm	115mm	141mm	168mm
12.5	128mm	125mm	135mm	169mm	202mm
15	129mm	125mm	156mm	197mm	237mm
17.5	131mm	125mm	179mm	226mm	273mm
20	133mm	125mm	201mm	256mm	310mm
22.5	135mm	125mm	224mm	286mm	348mm
25	138mm	125mm	249mm	318mm	388mm
27.5	141mm	125mm	274mm	352mm	430mm
30	144mm	125mm	300mm	386mm	473mm
32.5	133mm	115mm	313mm	409mm	504mm
35	140mm	115mm	345mm	450mm	555mm
37.5	139mm	110mm	371mm	486mm	601mm
40	144mm	110mm	404mm	530mm	656mm
42.5	149mm	110mm	439mm	577mm	714mm
45	156mm	110mm	479mm	629mm	778mm

