

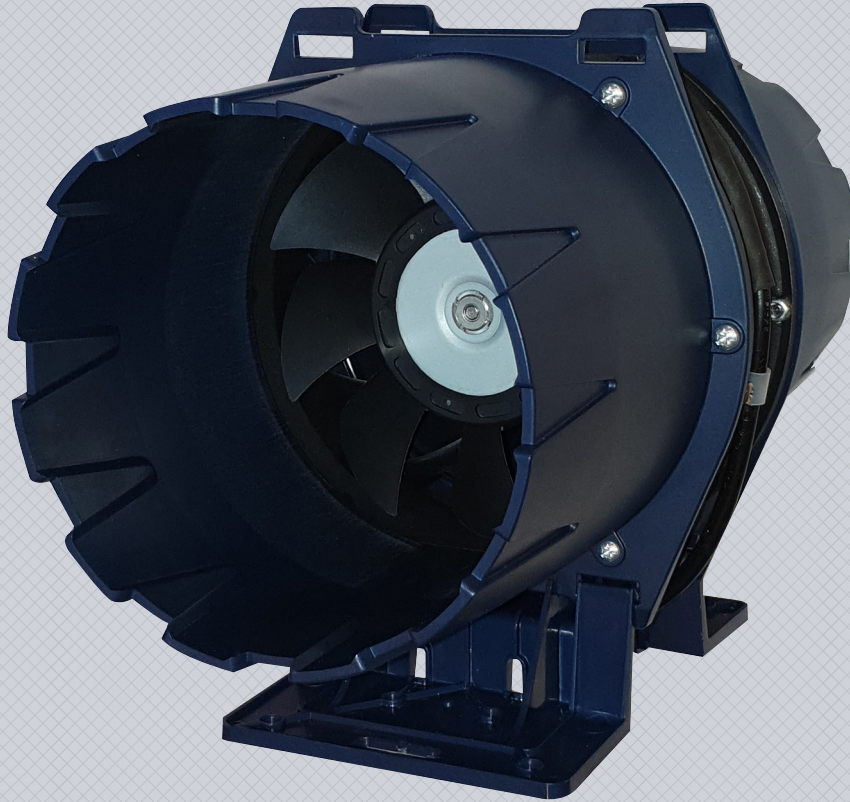

• VAF16 FAN •



Axial In-line EC Fan

114L/S
AIRFLOW

SUSPENDED
OR FIXED
MOUNTING

TAPERED
SPIGOTS

CLASS II
APPLIANCE

- Great for longer duct
- Quiet design
- Blades have been specifically designed to work in a ducted airflow environment

- Energy efficient
- Long motor life

R&D™ RESEARCHED &
DEVELOPED IN-HOUSE



• VAF16

Axial In-line

EC FAN

Energy efficient and durable.

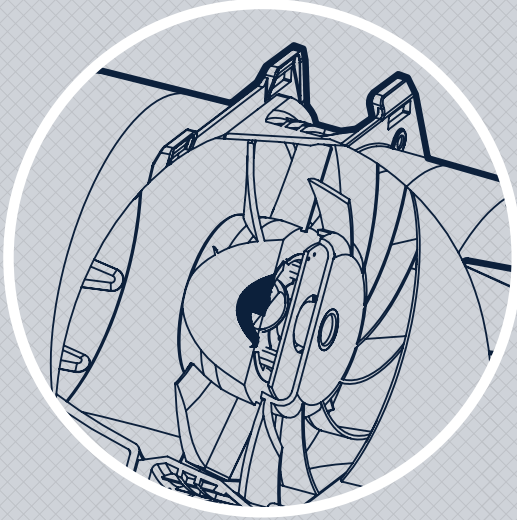

TAPERED SPIGOTS

Tapered longer spigots for duct
to slide on and tape easier.

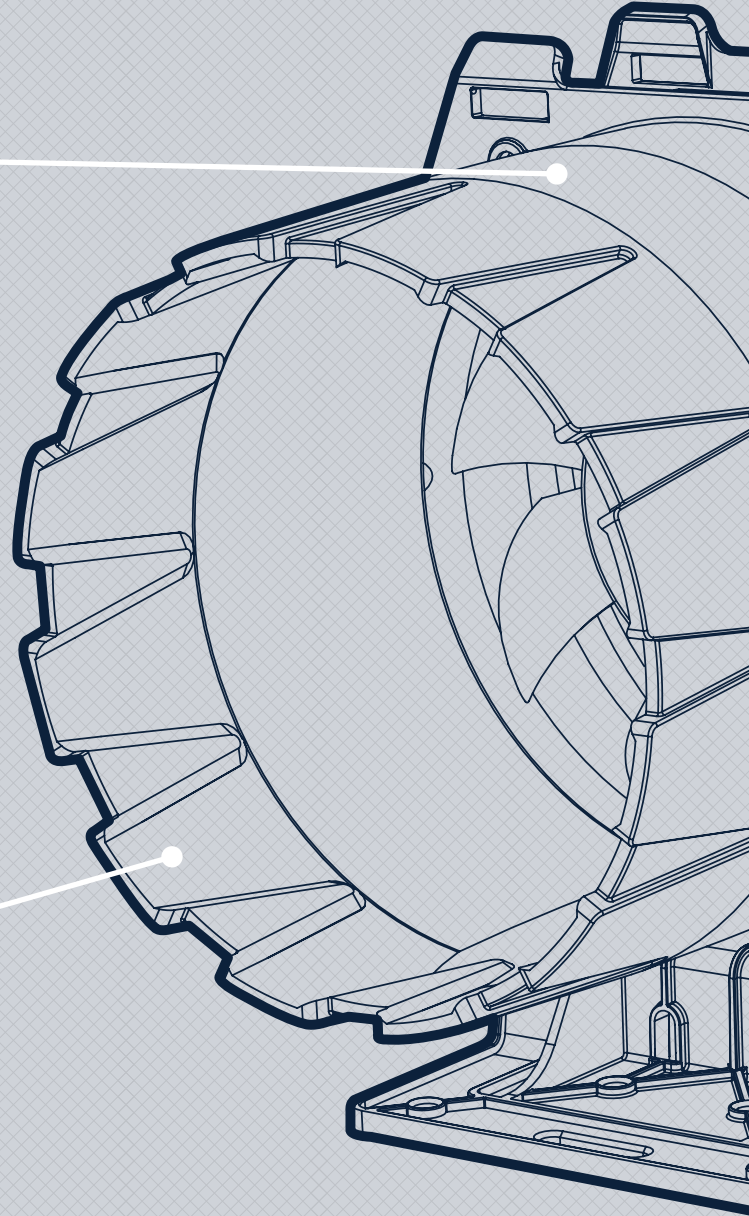
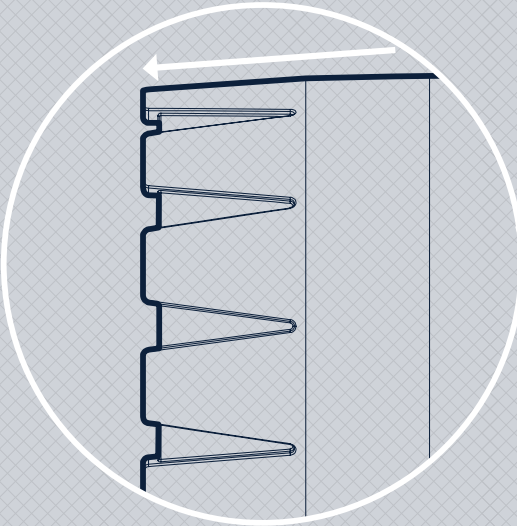

BOND GRILLES

The VAF16 fan kits are supplied
with our award-winning registered
design Bond Grilles.

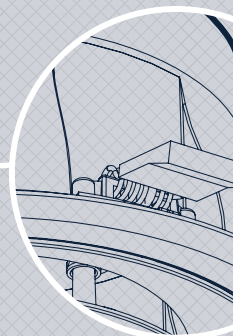
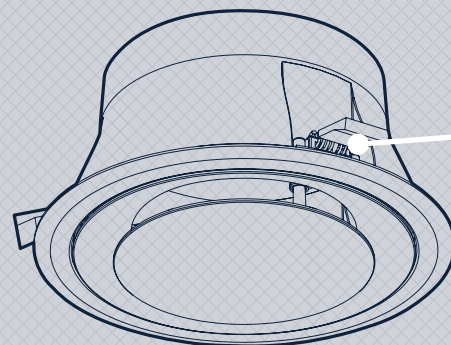

Easy clip instal



NCO

6 FAN •

ne EC Fan

MOUNTING OPTIONS

Versatile mounting options,
suspended or clip in mount base.

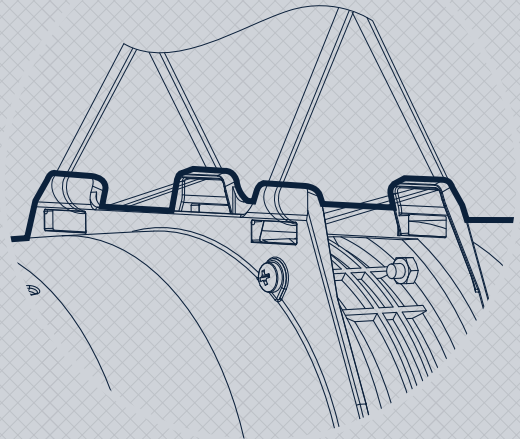
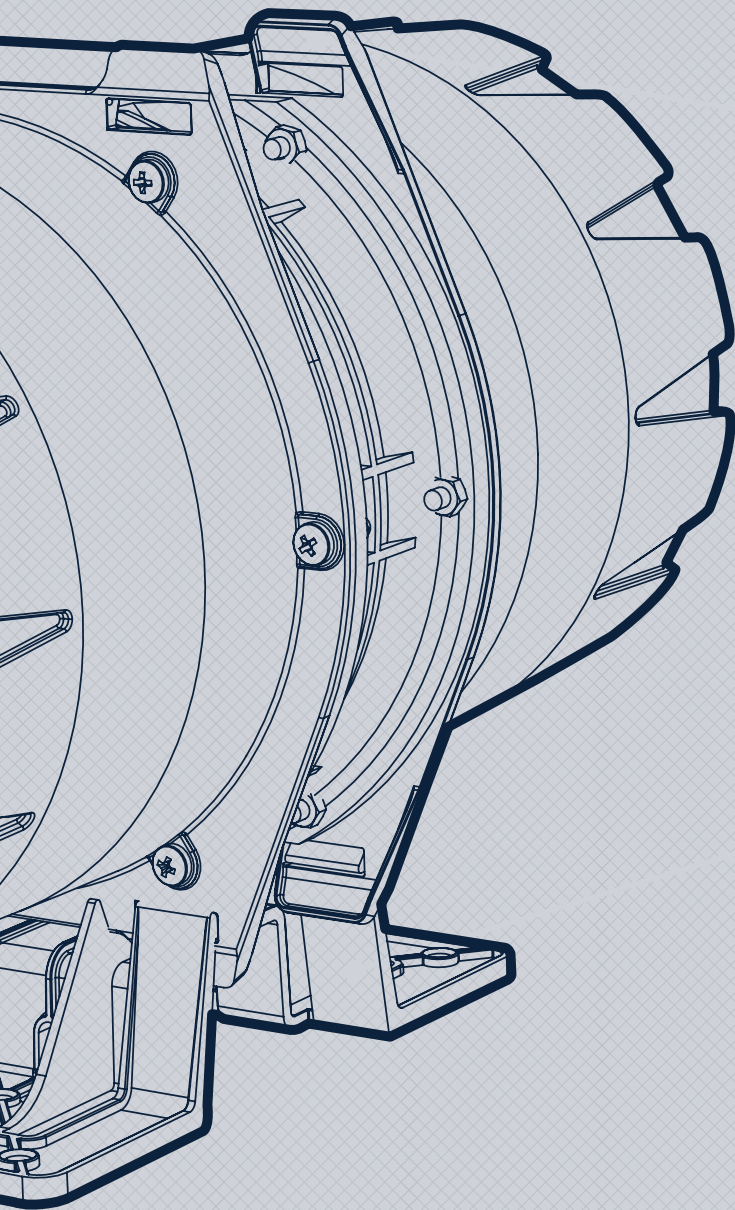

SUSPENDED

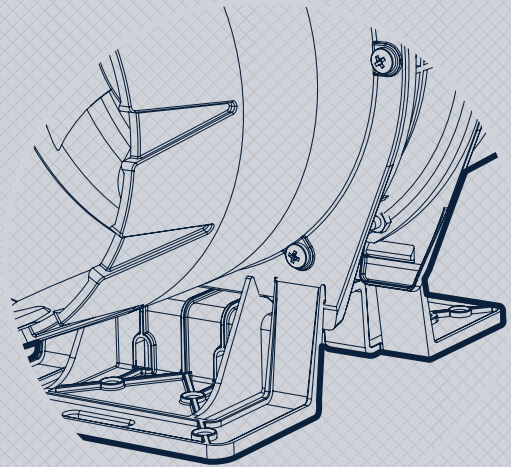

BASE MOUNTED



ation

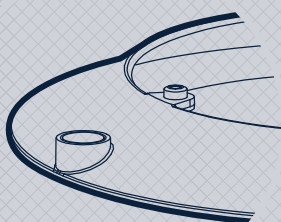

Magnetic grille removal

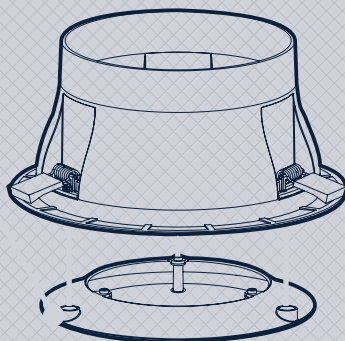

Designers Institute
of New Zealand
Best Design Awards
Winner 2019



DIMENSIONS

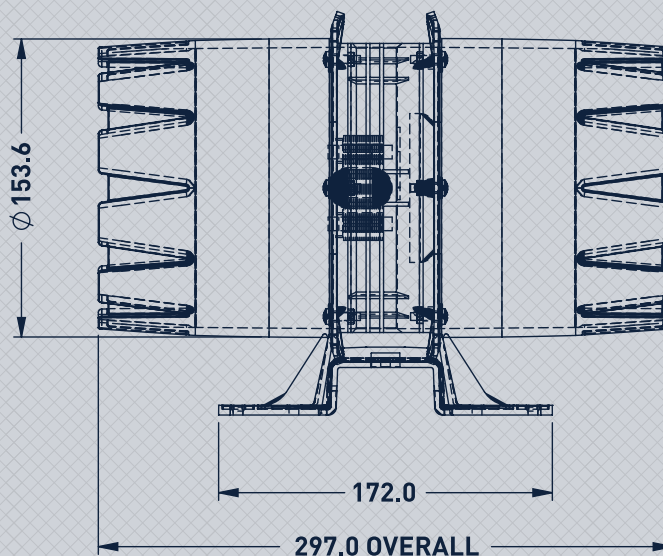
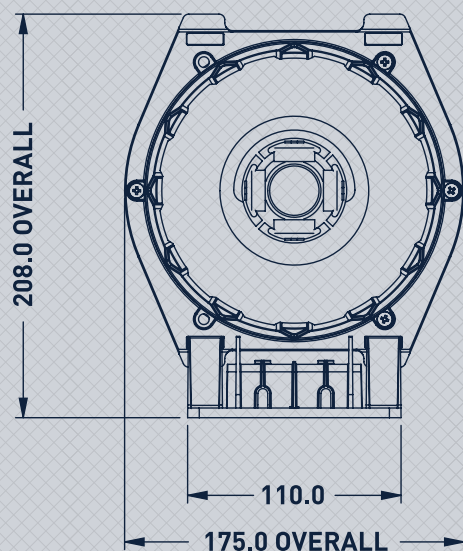

SPECIFICATIONS

CODE	WATTAGE	VOLTAGE	FAN BLADE	AIR FLOW	RPM	IP RATING	WARRANTY	TRADE PRICE
VAF16	20W	230-240V at 50Hz	150mm	410m ³ /h 114 L/s	2700r/min	IP44	5 YEAR	\$120.00

FAN KITS

CODE	KIT CONTENTS	TRADE PRICE
VF16K6BF	VAF16 Fan, White Round Bond Grille, White Reacher Square Fixed Grille, 6 Metre Ducting, Duct Tape, Cable Ties with Single Surface Socket.	\$170.00
VF16K6LF	VAF16 Fan, White Round Reacher Grille w/ Light*, White Reacher Square Fixed Grille, 6 Metre Ducting, Duct Tape, Cable Ties with Single Surface Socket.	\$250.00

*White Reacher Grille w/Light output is 700-750lm, 3000K/4000K/5700K, 80+ CRI, 150mm cut out. Suitable for Bathroom Zone 1.



VYNCO

Christchurch Office

388-396 Tuam Street, Phillipstown, Christchurch
PO Box 9022, Tower Junction, Christchurch 8149
P (+64) 3 379 9283 F (+64) 3 379 6838
E sales@vynco.co.nz

Auckland Office

9 Levene Place, Mt Wellington, Auckland
PO Box 12 249, Penrose, Auckland 1642
P (+64) 9 525 6051 F (+64) 9 525 5799
E sales@vynco.co.nz

find us:  