

Owner's Guide and Installation Instructions



Rheem Commpak[®] CP21-CP36 Commercial Hot Water Systems



Install a Rheem

*This water heater must be installed and serviced by a qualified person.
Please leave this guide with a responsible officer.*

Please read this manual prior to installing this product, it contains all the necessary technical and installation information that will be required by the contractor to correctly install & commission this system. This product must be installed & commissioned in accordance to the Rheem installation instructions, AS/NZS 5601.1, AS/NZS 3500.4, the relevant electrical & local authorities' requirements.

Operational design of this Hot Water System is protected by Australian Patent No: 2007201101.

CONTENTS

RESPONSIBLE OFFICER - We recommend you read pages 4 to 14.
The other pages are intended for the installer but may be of interest.

About your water heater	4
Water Supplies	12
Save A Service Call	13
Commpak Plus – Specifications	15
Installation – Water Heater.....	17
Connections - Plumbing	21
Connections- Electrical.....	22
Commissioning	30
Rheem Continuous Flow Gas Water Heater Warranty – Australia Only	74

ABOUT YOUR WATER HEATER

The RHEEM Commpak Plus CP21-36 is a dual bank system comprising of twenty one (21) to thirty six (36) electronic continuous flow water heaters.

Factory manifolded in a back to back arrangement, complete with dual pumps, temperature sensors and system controller.

All components are fully assembled on a lightweight frame suitable for floor mounting.

The RHEEM Commpak Plus CP21-36 is designed to provide mains pressure performance with a recirculating capacity for medium to large size developments and suitable for:

- Outdoor and Indoor installations.**
- Natural Gas or Propane (LPG).**
- Energy Consumption Control.**
- Domestic Hot Water (DHW).**

The RHEEM Commpak Plus CP21-36 is a fully engineered system; completely factory assembled & tested.

Requiring only minimal on-site works to be completed as detailed below:

1. Installation of the package & following 'Service Connections':

- a) Gas in b) Cold water in c) Hot water out
- d) Hot water return) Co-axial flueing for Individual Internal Water Heaters
- f) Pressure relief valve outlet – drain to tundish

2. 415V/3Ph/50Hz – Four (4) Core & Earth [4C&E] Power Supply to the controller:

Up front protection required: 20 A for 21 Heater Systems
25 A for 22-36 Heater Systems
Circuit breaker curve type: C or D curve.

Please ensure incoming power supply is connected to provide clockwise rotation. Failure to do so will cause the pumps to run backwards.

- 3. Remote alarm monitoring cabling to the controller (optional)**
- 4. Final commissioning as per the simple instructions provided.**

CP21-CP36: Models Available & Technical Data

CP21-CP36 Models	CPE21 & CPI21	CPE22 & CPI22	CPE23 & CPI23	CPE24 & CPI24	CPE25 & CPI25	CPE26 & CPI26	CPE27 & CPI27	CPE28 & CPI28	
Input	MJ/hr	4305	4510	4715	4920	5125	5330	5535	5740
Outdoor or Indoor – Refer to Model Type									
Installation									
Recovery Rate @ 50°C rise	L/hr	16632	17424	18216	19008	19800	20592	21384	22176
25°C rise		33264	34848	36432	38016	39600	41184	42768	44352
Peak Flow Rate @ 50°C rise	L/min	277.2	290.4	303.6	316.8	330.0	343.2	356.4	369.6
25°C rise		554.4	580.8	607.2	633.6	660.0	686.4	712.8	739.2
Dimensions									
Height	mm	2000	2000	2000	2000	2000	2000	2000	2000
Length(Back to Back)	mm	4750	4750	5110	5110	5470	5470	5830	5830
Depth (Back to Back)	mm	980	980	980	980	980	980	980	980
Clearance	mm	800	800	800	800	800	800	800	800
Cold Water Inlet	Flanged End To Table E	80mm							
Hot Water Outlet		80mm							
Gas	BSPTM	65mm							
Hot Water Return	BSPF	40mm							
Approximate Weight	kg	870	900	940	970	1000	1040	1070	1100
Water Supply Pressure		1000kPa Maximum & 150kPa Minimum with +/-50kPa fluctuation							
Gas Supply Pressure Range									
Natural	kPa	1.13 Minimum & 3.5 Maximum							
Propane	kPa	2.75 Minimum & 3.5 Maximum							
Power Supply 415V/3Ph/50Hz – 4C&E	FL Amps	12.0	13.0	13.0	13.0	14.0	14.0	14.0	15.0
Type C or D Curve Up Front Protection	Amps	20	25						

CP21-CP36: Models Available & Technical Data

CP21-CP36 Models	CPE29 & CPI29	CPE30 & CPI30	CPE31 & CPI31	CPE32 & CPI32	CPE33 & CPI33	CPE34 & CPI34	CPE35 & CPI35	CPE36 & CPI36
Input	MJ/hr	5945	6355	6560	6765	6970	7175	7380
Installation								
Recovery Rate @ 50°C rise	L/hr	22968	24552	25344	26136	26928	27720	28512
25°C rise		45936	49104	50688	52272	53856	55440	57024
Peak Flow Rate @ 50°C rise	L/min	382.8	409.2	422.4	435.6	448.8	462.0	475.2
25°C rise		765.6	818.4	844.8	871.2	897.6	924.0	950.4
Dimensions								
Height	mm	2000	2000	2000	2000	2000	2000	2000
Length(Back to Back)	mm	6190	6550	6550	6910	6910	7270	7270
Depth (Back to Back)	mm	980	980	980	980	980	980	980
Clearance	mm	800	800	800	800	800	800	800
Cold Water Inlet	Flanged End To Table E	100mm				100mm		
Hot Water Outlet	Table E	100mm				100mm		
Gas	BSPTM	65mm				80mm		
Hot Water Return	BSPF	50mm				50mm		
Approximate Weight	kg	1140	1200	1240	1270	1300	1340	1370
Water Supply Pressure		1000kPa Maximum & 150kPa Minimum with +/-50kPa fluctuation						
Gas Supply Pressure Range								
Natural	kPa	1.13 Minimum & 3.5 Maximum						
Propane	kPa	2.75 Minimum & 3.5 Maximum						
Power Supply 415V/3Ph/50Hz – 4C&E	FL Amps	15.0	15.0	16.0	16.0	17.0	17.0	17.0
Type C or D Curve Up Front Protection	Amps							

WATER HEATER OPERATION

Automatic safety controls are fitted to the water heater to provide safe and efficient operation.

HOW HOT SHOULD THE WATER BE?

The water heater has a maximum preset outlet temperature setting of 82°C. For applications requiring sanitising temperatures, the outlet temperature should be set at 82°C. The minimum recommended preset outlet temperature setting is 60°C.

If the water heater is installed as part of a circulated hot water flow and return system in a building, the preset outlet temperature setting of the water heater must be set to at least 60°C.

Note: The preset outlet temperature setting of this water heater cannot be adjusted by the householder. The setting can only be adjusted by the installer, Rheem Service or their nearest Accredited Service Agent.

Note: AS 3498 requires that a water heater provides the means to inhibit the growth of Legionella bacteria in potable water. When this water heater is used as an in-series booster for a solar water heater it can satisfy this AS 3498 requirement provided it is energised and the booster preset outlet temperature setting is 70°C or higher.

If this water heater is installed as part of a solar water heater system, the system can deliver water at temperatures from 58°C up to 75°C and possibly higher depending upon the model of solar water heater installed.

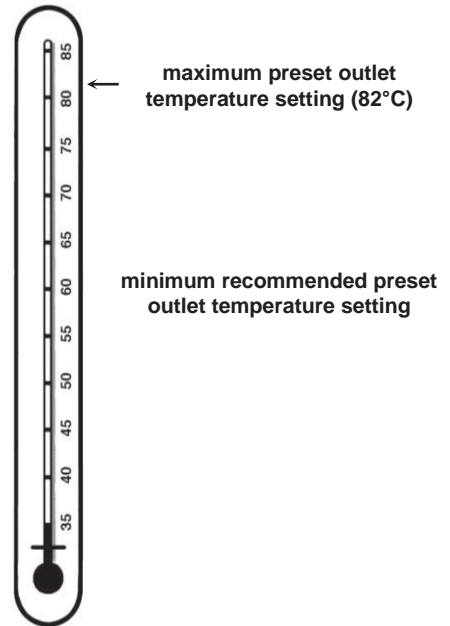

HOTTER WATER INCREASES THE RISK OF SCALD INJURY

This water heater can deliver water at temperatures which can cause scalding.

We recommend and it may be required by regulations that an approved temperature limiting device be fitted into the hot water piping to ablution, bathing and public areas when a Commpak Plus water heater is installed. This will keep the water temperature below the maximum permitted by AS/NZS 3500.4 to these areas.

The water heater uses 240 Volt AC electrical power for operation of the control systems and the combustion fan. The removal of the front panel will expose 240 V wiring. It must only be removed by a qualified person.

The power lead from the water heater must be plugged into a weatherproof electrical outlet. Take care not to touch the power plug with wet hands.

SAFETY

This water heater is supplied with temperature sensors, a FlameSafe® protection system and a pressure relief valve. These devices must not be tampered with or removed. The water heater must not be operated unless each of these devices is fitted and is in working order.

If the power supply cord or plug is damaged, it must be replaced by a qualified person in order to avoid a hazard. The power supply cord and plug must be replaced with a genuine replacement part available from Rheem. Phone Rheem Service or their nearest Accredited Service Agent to arrange for an inspection.

⚠ Warning: For continued safety of this water heater it must be installed, operated and maintained in accordance with the Owner's Guide and Installation Instructions.

The Rheem warranty may not cover faults if relief valves or other safety devices are tampered with or if the installation is not in accordance with these instructions.

- Do not store **flammable or combustible materials** near the water heater. Flammable liquids (such as petrol), newspapers and similar articles must be kept well away from the water heater and the flue terminal.
- Do not use **aerosols, stain removers and household chemicals** near the water heater whilst it is working. Gases from some aerosol sprays, stain removers and household chemicals become corrosive when drawn into a flame.
- Do not store **swimming pool chemicals, household cleaners**, etc., near the water heater.
- Do not place anything on top of the water heater or in contact with the flue terminal. Ensure the flue terminal is not obstructed in any way at any time.
- Do not use Propane / Butane gas mixtures in a Propane model. A Propane model is designed to operate on Propane only. The use of Propane / Butane mixture, such as automotive LPG fuel, in a Propane model is unsafe and can cause damage to the water heater.

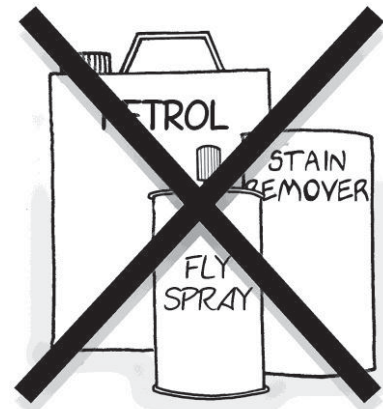

PRECAUTIONS

Where damage to property can occur in the event of the water heater leaking, the water heater must be installed over a safe tray. Construction, installation and draining of a safe tray must comply with AS/NZS 3500.4 and all local codes and regulatory authority requirements.

The water heater must be maintained in accordance with the Owner's Guide and Installation Instructions. Refer to "General Maintenance" on page 9, "Minor Six Month Maintenance" on page 9 and "Annual Service" on page 9.

If this water heater is to be used where an uninterrupted hot water supply is necessary for your application or business you should ensure that you have back up redundancy within the hot water system design. This should ensure the continuity of hot water supply in the event that this water heater were to become inoperable for any reason. We recommend you seek advice from your plumber or specifier about your needs and building back up redundancy into your hot water supply system.

GENERAL MAINTENANCE

The jacket of the water heater can be cleaned with a soft cloth and warm mild soapy water. Under no circumstances should abrasive materials or powders be used.

The area around the water heater can be sprayed with insecticide to rid the area of insects. Insects encroaching into or nesting in the water heater can interfere with the operation of the water heater and also damage components.

MINOR SIX MONTH MAINTENANCE

It is recommended minor maintenance be performed every six months by the dwelling occupant.

The minor maintenance includes:

Inspect around the air inlet, flue terminal and the water heater in general for plant growth.

- Trim back any shrubs, bushes or other plants which have encroached around the water heater.

Plant growth across the air let and flue terminal can interfere with the performance of the water heater.

- Inspect around the water heater for insect infestations, such as ants.
- Spray insecticide around the water heater if necessary to rid the area of insects. Do not spray the surface or into the air inlet or flue terminal of the water heater.

Insects encroaching into or nesting in the water heater can interfere with the operation of the water heater and also damage components.

- Check the drain line from the safe tray (if one is installed) is not blocked.
- Check and clean line strainers on the cold water inlet and hot water return.
- Check and clean filter on CFWH cold water inlet.

ANNUAL SERVICE

For safe and efficient operation, it is recommended an annual service be conducted on the water heater. Only genuine replacement parts should be used on this water heater.



Warning: Servicing of a water heater must only be carried out by qualified personnel. Phone Rheem Service or their nearest Accredited Service Agent.

The annual service includes the following actions:

- Check and if necessary adjust the gas pressure.
- Check the operation of and clean the burner.
- Visually check the unit for any potential problems.
- Inspect all connections.
- Check the drain line from the safe tray (if one is installed) is not blocked.
- Check and clean line strainers on the cold water inlet and hot water return.
- Check and clean filter on CFWH cold water inlet.

TO TURN OFF THE WATER HEATER

If it is necessary to turn off the water heater:

- Switch off the electrical supply at the circuit breaker isolating switch to the water heater if there is no risk of freezing conditions occurring (refer to note below).
- Close the gas isolation valve at the inlet to the water heater.
- Close the cold water isolation valve at the inlet to the water heater.
- Close the hot water return isolation valve.

Note: If there is a risk of freezing conditions, the electrical supply to the water heater should not be switched off unless the water heater is drained, otherwise damage could result (refer to “[Frost Protection](#)” on page 11 and “[Draining the Water Heater](#)” on page 11).

TO TURN ON THE WATER HEATER

- Screw in the drain plugs at the cold water inlet and hot water outlet of the CFWH if they have been drained.
- Open all of the hot taps. (don't forget the shower).
- Open the cold water isolation valve fully at the inlet to the water heater.

Air will be forced out of the taps.

- Close each tap as water flows freely from it.
- Open the gas isolation valve fully at the inlet to the water heater.
- Switch on the electrical supply at the circuit breaker isolating switch.
- The water heater will operate automatically.

FROST PROTECTION

The water heater has a frost protection system. The frost protection system will protect the water heater from damage, by preventing ice forming in the waterways of the water heater, in the event of freezing conditions occurring.

Notes:

- The frost protection system will be rendered inoperable if electrical power is not available at the water heater. Damage caused by freezing due to the unavailability of power at the water heater is not covered by the Rheem warranty (refer to [“Terms of the Rheem Warranty”](#) on page 75).
- If it is necessary to switch the power off to the water heater and there is a risk of freezing, then it is necessary to drain the water heater (refer to [“Draining the Water Heater”](#) on page 11).
- Pipe work to and from the water heater must be adequately insulated to prevent freezing.
- The water heater is not suitable for installation in areas where the ambient temperature falls below -20°C (including wind chill factor).
- Refer to [“Terms of the Rheem Warranty”](#) on page 75.

DRAINING THE WATER HEATER

To drain the water heater:

- Turn off the water heater (refer to [“Turn Off The Water Heater”](#) on page 10).
- Open the pressure relief valve on the Commpak located on the hot manifold.
- Unscrew the two drain plugs, one each at the cold water inlet and hot water outlet, on the underside of continuous flow water heater.

Water will drain from the water heaters.

- When water stops flowing from the water heaters, close the pressure relief valve.

Note: It is recommended not to screw the drain plugs back in, until the water heater is to be turned on again.

HOW DO I KNOW IF THE WATER HEATER IS INSTALLED CORRECTLY?

Installation requirements are [shown on pages 17 to 20](#) The water heater must be installed:

- by a qualified person, and
- in accordance with the installation instructions, and
- in compliance with Standards AS/NZS 3500.4, AS 5601 or AS/NZS 5601.1, as applicable under local regulations, and all local codes and regulatory authority requirements.

DOES THE WATER CHEMISTRY AFFECT THE WATER HEATER?

The water heater is suitable for most public water supplies, however some water chemistries may have detrimental effects on the water heater, its components and fittings. Refer to [“Water Supplies”](#) on page 12.

If you are in a known harsh water area or you are not sure of your water chemistry, have your water checked against the conditions [described on page 12](#).

HOW LONG WILL THE WATER HEATER LAST?

The water heater is supported by a manufacturer’s warranty ([refer to page 77](#)). There are a number of factors that will affect the length of service the water heater will provide. These include but are not limited to the water chemistry, the water pressure, the water temperature (inlet and outlet) and the water usage pattern. Refer to [“Precautions”](#) on page 9.

WATER SUPPLIES

This water heater must be installed in accordance with this advice to be covered by the Rheem warranty.

This water heater is manufactured to suit the water conditions of most public reticulated water supplies. However, there are some known water chemistries which can have detrimental effects on the water heater and its operation and / or life expectancy. If you are unsure of your water chemistry, you may be able to obtain information from your local water supply authority. This water heater should only be connected to a water supply which complies with these guidelines for the Rheem warranty to apply.

CHANGE OF WATER SUPPLY

The changing or alternating from one water supply to another can have a detrimental effect on the operation and / or life expectation of a heat exchanger in a continuous flow water heater.

Where there is a changeover from one water supply to another, e.g., a rainwater tank supply, bore water supply, desalinated water supply, public reticulated water supply or water brought in from another supply, then water chemistry information should be sought from the supplier or it should be tested to ensure the water supply meets the requirements given in these guidelines for the Rheem warranty to apply.

SATURATION INDEX

The saturation index (SI) is used as a measure of the water's corrosive or scaling properties.

In a corrosive water supply, the water can attack copper parts and cause them to fail. Where the saturation index is less than -1.0 , the water is very corrosive and the Rheem warranty does not apply to a copper heat exchanger in a continuous flow water heater or Commpak pipe work.

In a scaling water supply calcium carbonate is deposited out of the water onto any hot metallic surface. Where the saturation index exceeds $+0.80$, the Rheem warranty does not apply to a copper heat exchanger in a continuous flow water heater Commpak pipe work.

Water which is scaling may be treated with a water softening device to reduce the saturation index of the water.

Refer to the [Saturation Index chart](#) on page 12.

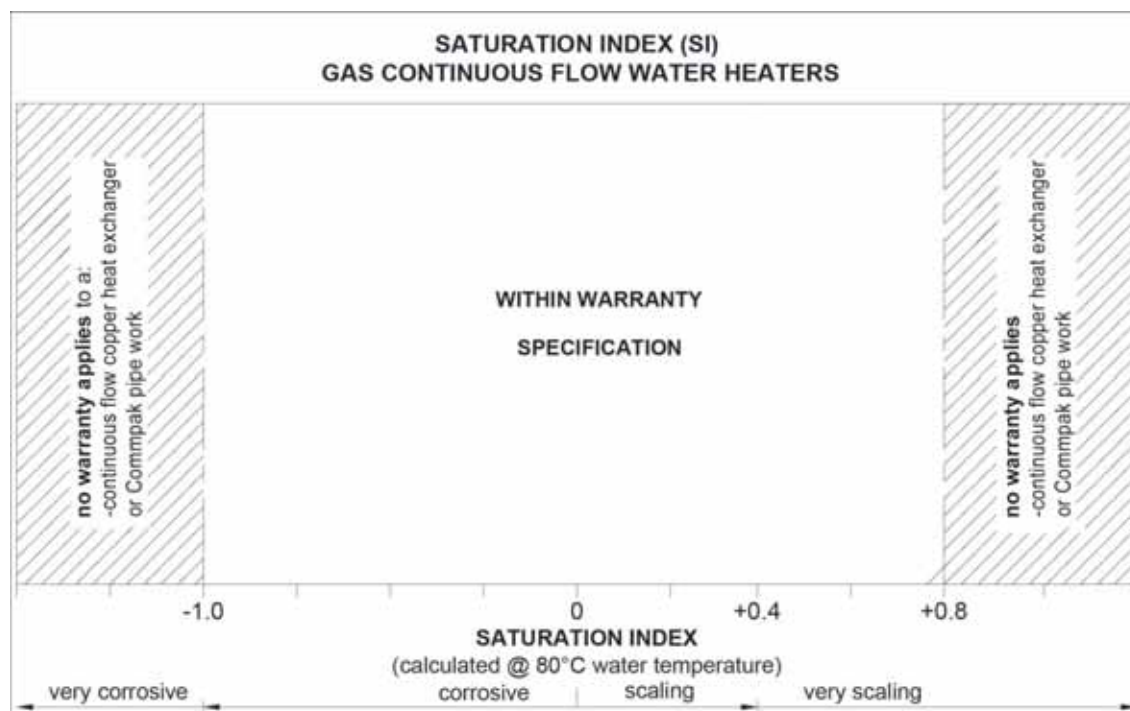

SAVE A SERVICE CALL

Check the items below before making a service call. You will be charged for attending to any condition or fault, which is not related to manufacture or failure of a part (refer to “[Terms of the Rheem Warranty](#)” on page 75).

COLD WATER FROM THE HOT TAP

- Is the continuous flow water heater plugged in and is the power at the isolating switch on?
- Is power available in the premises?
Try using another electrical appliance.
- Is the isolation valve in the gas line open?
- Is there a gas supply to the rest of the premises?
Try lighting another gas appliance.
- Has the gas line been purged of air after installation?
Refer to your plumber.

WATER IS TOO HOT OR NOT HOT ENOUGH

- Is the preset outlet temperature of the water heater higher than required?

NO WATER FROM THE HOT TAP

No flow of water from the hot tap may indicate a restriction in or failure of the cold water supply to the water heater. Check for water flow at other taps and that the cold water isolation valve is fully open.

WATER TEMPERATURE FLUCTUATES

The Commpak is supplied with a water flow compensating device which will activate if the maximum water flow capability of the system is exceeded. This will maintain pressure and flow within the system at the expense of temperature. Temperature fluctuation can also be evident if the Commpak has been installed as an in-series booster to a solar water heater.

FAN CONTINUES TO RUN AFTER WATER HEATER OPERATION STOPS

It is the normal operation of the water heater for the fan to continue running after heating of the water is finished. The fan may run for up to six minutes after the burners extinguish, to prepare for the next ignition.

CLOUDS OF WHITE ‘VAPOUR’ FROM THE FLUE TERMINAL

During the heating cycle, it is not unusual to see water vapour clouds steaming from the flue terminal, particularly on cold days. This is normal operation of the water heater.

PRESSURE RELIEF VALVE DISCHARGING

A pressure relief valve is incorporated into the water heater controls and the Commpak manifold. These valves protect the water heater, by allowing water to escape, in the event of excessive pressure build up in the waterways.

- **Normal operation**
A small volume of water may discharge from the bottom of the water heater when a hot tap is suddenly closed.
- **Continuous dribble**
A continuous dribble may indicate the water supply pressure is above the design pressure for the water heater. If so, a pressure limiting valve must be installed on the cold water supply pipe to the water heater (refer to “[Mains Water Supply](#)” on page 19).

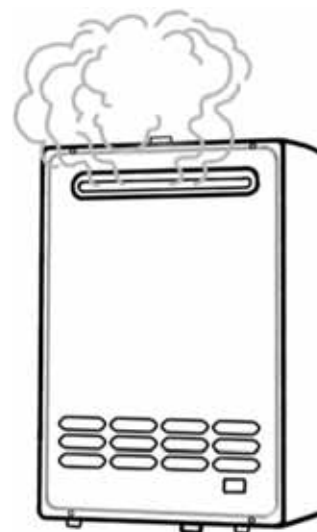

ERROR CODE

The water heater provides a diagnostic error code in the event of an interruption to its operation. The error code is displayed on the OK MONITOR on the front of the water heater as a numerical value. If an error code appears:

- Close the isolation valve at the outlet of the CFWH and unplug the electrical supply to the CFWH.
- Check the gas isolation valve at the gas inlet to the CFWH is fully open.
- Wait 5 minutes, then plug in the electrical supply to the water heater, and open the isolating valve.

If the error code persists, take note of the numerical code and isolate the CFWH. Phone Rheem Service or their nearest Accredited Service Agent to arrange for inspection.



IF YOU HAVE CHECKED ALL THE FOREGOING AND STILL BELIEVE YOU NEED ASSISTANCE, PHONE RHEEM SERVICE OR THEIR NEAREST ACCREDITED SERVICE AGENT.

COMMPAK PLUS – SPECIFICATIONS

The Rheem Commpak Plus CP21-36 hot water system is completely designed, manufactured, factory tested & supplied.

Operational design of this hot water system is protected by “Australian Patent 2007201101”.

Specifications brief below:

DESIGN BASIS:

Water regulation pumps maintain the hot water supply at mains pressure over the CP21-36 design capacity. Pumps plumbed to the water inlets of the RHEEM Electronic Continuous Flow Water Heaters (CFWH) to overcome friction losses inherent within the CFWH.

A flow compensation device has also been provided to cater for flow rates exceeding the heated water systems designed capability. This device has been installed between the cold water inlet & hot water outlet of the system to automatically provide additional water flow as per the operation of conventional hot water storage vessel systems.

A pressure responsive differential bypass valve has also been provided to facilitate for an adjustable recirculation flow rate regulation means. This facility also provides for an internal recirculation means to ensure sufficient flow is always maintained through the CFWH for firing and continuous operation. This feature is especially useful for dead leg (no return) hot water applications or systems suffering from poorly designed / built recirculation loops.

UNIQUE FEATURES

- Automatic operation of the water regulation pumps for both primary and secondary water reticulation
- Heated water within the reticulation system is supplied at mains water pressure with automatic compensation to cater for flow demands in excess of design requisites.
- Separate circulating pump/s no longer required
- Hot water storage vessel(s) no longer required
- Capital and operating cost savings
- Smaller space requirements

CONTINUOUS FLOW WATER HEATER(S) (CFWH):

Required numbers are assembled in a back to back arrangement and hydraulically balanced. 100% duty achieved by operation on demand.

WATER REGULATION PUMPS (refer to pages 40-54 for full details)

- Pump wetted parts suitable for potable water application.
- Continuous rated to handle hot water up to 110°C.
- 1000 kPa operating pressure, with +/- 50kPa fluctuation.
- 415V/3PH/50Hz – 4C&E continuous rated IP55 motor wired to the controller.
- Pumps integrated into the hot water system with isolation valves / check valves / strainers and required plumbing / fittings.
- Loss of water supply pressure switch mounted and wired to the controller. Pressure switch able to be tested in situation without isolating water supply to the hot water system.

PLUMBING AND HOT WATER PIPING INSULATION

- Complete cold water and hot water piping; valves and fittings all in accordance to AS/NZS3500.4:2003
- Hot water piping insulation details:
- Closed cell PE Foam clad with a reinforced UV resistant foil facing, suitable for outdoor usage.
- Operating temperature to 105°C
- Rated ‘R’ Value of 1.0 or greater
- Compliance In accordance with AS/NZS3500.4:2003, Amendment 1: 2005; Section 8.2.1 (Piping for Water Heaters) to all climate regions and external locations.
- Complete natural gas piping; valves and fitting as per AS5601.1

SKID PACKAGE

- All water heaters, pumps, plumbing manifolds and controller mounted on a common base.
- Package is factory tested and ready for on-site installation

SYSTEM CONTROLLER:

Refer to Pages 56-73 for full details.

INSTALLATION – WATER HEATER

**THIS WATER HEATER IS FOR OUTDOOR OR INDOOR INSTALLATION, MODEL DEPENDANT.
THIS WATER HEATER IS NOT SUITABLE FOR POOL HEATING.
Check the water heater is suitable for the gas type available.
(refer to the rating label on the water heater)**

INSTALLATION STANDARDS

The water heater must be installed:

- by a qualified person, and
- in accordance with the installation instructions, and
- in compliance with Standards AS/NZS 3500.4, AS 5601 or AS/NZS 5601.1, as applicable under local regulations, and all local codes and regulatory authority requirements.

All packaging materials must be removed from the water heater prior to its installation.

WATER HEATER APPLICATION

This water heater is designed for the purpose of heating potable water. Its use in an application other than this may shorten its life.

If this water heater is to be used where an uninterrupted hot water supply is necessary for the application or business, then there should be redundancy within the hot water system design. This should ensure the continuity of hot water supply in the event that this water heater was to become inoperable for any reason. We recommend you provide advice to the system owner about their needs and building backup redundancy into the hot water supply system.

Note: AS 3498 requires that a water heater provides the means to inhibit the growth of Legionella bacteria in potable water. When this water heater is used as an in-series booster for a solar water heater it can satisfy this AS 3498 requirement provided it is energised and the booster preset outlet temperature setting is 70°C or higher.

WATER HEATER LOCATION

The water heater should be installed in a position chosen with safety and service in mind. If this water heater is part of a solar water heater system, it should also be installed close to the solar storage tank. Make sure people (particularly children) will not touch the flue terminal. The flue terminal and air inlet must be clear of obstructions and shrubbery.

Clearance must be allowed for servicing of the water heater. The water heater must be accessible without the use of a ladder or scaffold. Make sure the entire front panel can be removed for service. You must be able to read the information on the rating plate. Remember you may have to remove a water heater later for servicing.

The water heater must be installed vertically upright and can be mounted in any location on a solid base. The frame must be secured to the floor at all anchor points provided.

The water heater must not be installed in an area with a corrosive atmosphere where chemicals are stored or where aerosol propellants are released. Remember the air may be safe to breathe, but when it goes through a flame, chemical changes take place which may attack the water heater.

OUTDOOR INSTALLATION

If outdoors a secondary flue is not required. The water heater must not be installed indoors or in a confined space.

The water heater must be located to ensure that the location of the flue terminal complies with the requirements of AS 5601 or AS/NZS 5601.1, as applicable under local regulations. As a guide the following requirements are extracted from the AS 5601. The distances are measured along the wall behind the water heater.

- At least 300 mm between the top of the flue terminal and the eaves.
- At least 500 mm between the flue terminal and the edge of any opening into the building, such as an openable door or window, measured horizontally*.
- At least 1500 mm between the top of the flue terminal and the edge of any opening into the building, such as an openable window, measured vertically.
- At least 300 mm between the flue terminal and a return wall or external corner, measured horizontally*.
- At least 1500 mm between the flue terminal and any opening into a building, in the direction of the flue discharge.
- At least 500 mm between the flue terminal and a fence, wall or other obstruction, in the direction of the flue discharge.

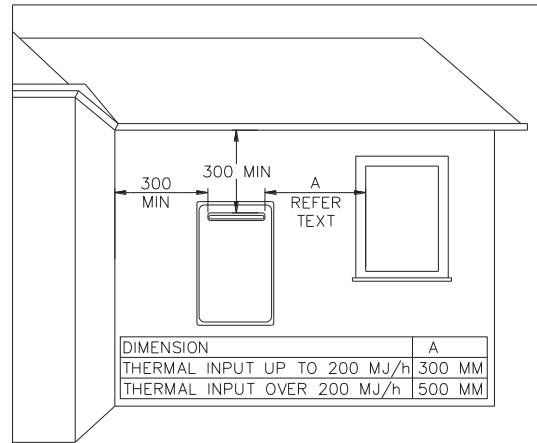

Note: * If these horizontal distances cannot be achieved, AS/NZS 5601.1 states an equivalent horizontal distance measured diagonally from the nearest discharge point of the flue terminal to the opening may be deemed to comply. Check with the local regulator.

Note: Two or more of this model CFWH can be installed side by side with minimal clearance between them. The AGA has approved the installation of two or more of this model CFWH with an exemption from the 300 mm minimum clearance requirements between flue terminals, as stated in AS 5601, clause 5.13.6.5 and AS/NZS 5601.1, clause 6.9.3.

INDOOR INSTALLATION

VENTILATION

This water heater is to be installed with a Rheem coaxial flue system. The kit enables a room sealed installation, drawing air for combustion from outside of the building.

The ventilation of a room or an enclosure such as a cupboard, where the water heater is installed must comply with the requirements of AS 5601 or AS/NZS 5601.1, as applicable under local regulations.

SECONDARY FLUE

A secondary flue must be installed with an indoor water heater to discharge combustion products to outside the building. The water heater **MUST ONLY** be installed with a certified Rheem coaxial flue system.

Where more than one water heater is installed, each water heater must be individually flued using a certified Rheem coaxial flue system. A common flue system **MUST NOT** be used. Refer to the CFWH Owner's Manual for details of flue installation.

SAFE TRAY

Where damage to property can occur in the event of the water heater leaking, the water heater must be installed over a safe tray. Construction, installation and draining of a safe tray must comply with AS/NZS 3500.4 and all local codes and regulatory authority requirements.

FROST PROTECTION

The water heater has a frost protection system. The frost protection system will protect the water heater from damage, by preventing ice forming in the waterways of the water heater, in the event of freezing conditions occurring.

The frost protection system will be rendered inoperable if electrical power is not available at the water heater. Damage to the water heater caused by freezing of the pipe work to or from the water heater is not covered under the Rheem warranty. Refer to AS/NZS 3500.4 for precautions to be taken for installations in frost prone areas. The water heater is not suitable for installation in areas where the ambient temperature falls below -20°C (including wind chill factor).

MAINS WATER SUPPLY

Where the mains water supply pressure exceeds that shown in the table below, an approved pressure limiting valve is required and should be fitted.

Relief valve setting	1000 kPa
Max. mains supply pressure	800 kPa
Min. mains supply pressure *	150 kPa

* minimum water supply pressure required to achieve the rated flow and performance

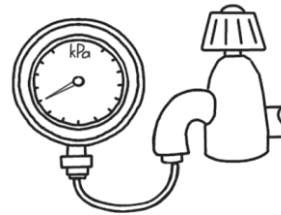

Notes:

- It is not recommended to install this water heater with a low pressure water supply.
- A minimum water supply pressure of 150 kPa is required to achieve the rated flow and performance of the water heater.
- If this water heater is installed as an in-series gas booster for a solar water heater, the maximum water supply pressure to the solar water heater, without an expansion control valve (ECV), is generally 800 kPa, however it may be less than this for some models. Refer to the Owner's Guide and Installation Instructions supplied with the solar water heater for maximum mains supply pressure details.
- This water heater is not suitable for connection to bore water or spring water unless a water treatment device is fitted.
- Refer to "Water Supplies" on page 12 for further information on water chemistry.

PRESET OUTLET TEMPERATURE SETTING

The factory preset outlet temperature setting of the water heater is:

- 70°C as part of a Commpak system

It is usually not necessary to check or adjust the factory preset outlet temperature setting of the water heater, unless the customer or application has a particular requirement for this to be done.

For applications requiring sanitising temperatures, such as a commercial kitchen, it will be necessary to adjust the preset outlet temperature setting of the CFWH and the controller to achieve and maintain sanitising temperatures up to 82°C. Refer to page 35 for details.

If the water heater is installed as part of a circulated hot water flow and return system in a building, the preset outlet temperature setting must be set to at least 60°C. If the water temperature decreases by more than 5°C through a circulated hot water flow and return system due to heat loss in the ring main, the preset outlet temperature setting of the water heater should be set to at least 65°C.

GAS BOOSTER FOR A SOLAR WATER HEATER

Note: AS 3498 requires that a water heater provides the means to inhibit the growth of Legionella bacteria in potable water. When this water heater is used as an in-series booster for a solar water heater it can satisfy this AS 3498 requirement provided it is energised and the booster preset outlet temperature setting is 70°C or higher.

HOT WATER DELIVERY

This water heater can deliver water at temperatures which can cause scalding.

It is necessary and we recommend that a temperature limiting device be fitted into the hot water piping to any ablution and public areas such as a bathroom, ensuite or public amenities when a Commpak water heater is installed to reduce the risk of scalding. The installing plumber may have a legal obligation to ensure the installation of this water heater meets the delivery water temperature requirements of AS/NZS 3500.4 so that scalding water temperatures are not delivered to a bathroom, ensuite or other ablution or public area.

The temperature limiting device used with a continuous flow gas water heater should have:

- a specified 'minimum temperature differential' between the hot water inlet and the tempered water outlet of no greater than 10°C, and
- a specified 'maximum permitted pressure variation' in the supply between the hot water inlet and the cold water inlet of no less than 15%.

Refer to the specifications of the tempering valve.

TEMPERATURE LIMITING DEVICE

A temperature limiting device cannot be installed in circulated hot water flow and return pipe work, unless it is specifically designed to do so, such as the Rheem Guardian warm water system. The tempered water from a temperature limiting device cannot be circulated. Where a circulated hot water flow and return system is required in a building, a temperature limiting device can only be installed on a dead leg, branching off the circulated hot water flow and return pipe.

If circulated tempered water were to be returned back to the water heater, depending on the location of the return line connection on the water supply line to the water heater, then either:

- water will be supplied to the cold water inlet of the temperature limiting device at a temperature exceeding the maximum recommended water supply temperature, or
- when the hot taps are closed no water will be supplied to the cold water inlet of the temperature limiting device whilst hot water will continue to be supplied to the hot water inlet of the temperature limiting device.

These conditions may result in either water at a temperature exceeding the requirements of AS/NZS 3500.4 being delivered to the hot water outlets in the ablution areas, or the device closing completely and not delivering water at all, or the device failing. Under either condition, the operation and performance of the device cannot be guaranteed.

CONNECTIONS - PLUMBING

SITE LOCATION

- External Systems - Recommended 800mm access clearance from horizontal flue outlets
- Internal Systems - Recommended 600mm access clearance.
- Refer: Australian Standard Gas Installations AS 5601 or AS/NZS 5601.1 for further requirements.
- Secure to the floor as appropriate.
Consult with site structural engineer for any specific securing requirements.
- Connect both cold water and hot water piping / valves and fittings as per the requirements of AS3500.4
- Water Supply Pressure: 150kPa Minimum to 1000kPa Maximum with acceptable **pressure fluctuations (±50kPa)**.
- Connect natural gas piping / valves and fitting as per the requirements of AS 5601 or AS/NZS 5601.1
 - Natural gas working pressure 1.13 kPa minimum to 3.5 kPa maximum
 - Propane gas working pressure 2.75 kPa minimum to 3.5 kPa maximum..
 - A secondary flue must be installed with an indoor water heater to discharge combustion products to outside the building. Each water heater must be individually flued using a Rheem approved coaxial flue system. A common flue system MUST NOT be used.

Refer to the Owner's guide and installation instructions supplied for the 862627 indoor CFWH model for further details.

- Drainage: Provide appropriately designed drainage system in compliance to applicable building codes and regulations to prevent property and equipment damage.

PIPE SIZES

The pipe sizing for hot water supply systems should be carried out by persons competent to do so, choosing the most suitable pipe size to ensure adequate flow for each individual application. Reference to the technical specifications of the water heater and local regulatory authority requirements must be made.

To achieve true mains pressure operation, the cold water line to the water heater should be the same size or bigger than the hot water line from the water heater.

IN-SERIES BOOSTER

The pipe work between the solar storage tank (if one is installed) and the in-series gas booster, **MUST BE** of copper and be fully insulated with a closed cell type insulation or equivalent in accordance with the requirements of AS/NZS 3500.4.

The insulation must be weatherproof and UV resistant if exposed. The insulation must be fitted up to the connections on the solar storage tank

GAS INLET

The gas connection is made on the left hand side of the water heater. The pipe work must be cleared of foreign matter before connection and purged before attempting to operate the water heater. An isolation valve and disconnection union must be installed to allow servicing and removal of the water heater.

Note: Refer to the Gas Installations Standard AS 5601 or AS/NZS 5601.1 for the correct method of sizing the gas supply pipe to the water heater. The pipe size selection must take into account the high gas input of this water heater as well as all of the other gas appliances in the premises.

⚠ Warning: Always isolate the water heater before pressure testing the gas supply system. Disconnect the water heater after the isolation valve to prevent the risk of serious damage to the gas control. The Rheem warranty does not cover damage of any nature resulting from failure to observe this precaution. Refer to rating label for gas types and pressures.

CONNECTIONS- ELECTRICAL

All electrical work and permanent wiring must be carried out by a qualified person and in accordance with the Wiring Rules AS/NZS 3000 and all local codes and regulatory authority requirements.

The water heater will only operate on a sine wave at 50 Hz. Devices generating a square wave cannot be used to supply power to the water heater.

HOT WATER SYSTEM CONTROLLER

- **Power supply: 415V/3Ph/50Hz – 4C&E power supply to the controller.**
 - Up front protection required: 20 A for 21 Heater Systems
A for 22-36 Heater Systems
 - Circuit breaker curve type: C or D curve.

- Hard wired: To the requirements of AS/NZS 3000:2007 Wiring Rules

This page is intentionally blank

COMMPAK PLUS – CP21-36 MAJOR ITEMS LISTING



COMMPAK PLUS – CP21-36 MAJOR ITEMS LISTING



COMMPAK PLUS – MAJOR ITEMS LISTING

Refer to photographs (Pages 24 & 25); Major items listings / identification (Pages 26 & 27) and External & Internal Commpak general drawings (Pages 28 & 29)

Item No.	Description	Function	RHEEM Part No's.
1	System Controller + Control Module	Starts and stops pumps Displays outlet and inlet water temperature Refer: System controller material schedule – Page 68 For material ordering details	Control Module: UP-TCM-3-DP
2	Water heater general purpose power outlets	240VAC – 1 Phase – 10A x 3 Outlets Local power supply for water heaters	B-GPO-3
3	Temperature Sensor	Water inlet temperature sensor – T1	TSP
3A	Temperature Sensor	Water outlet temperature sensor – T2	TSP
4	Pumps	System water supply and return circulation Refer: pump details – Pages 40-53	P-3LS4 -40
4A	Pump Mechanical Seal	Seal between pump wet end and motor end. Refer: pump details – Page 47	MS-3LS4-32-40
5	Hot water connector	20mm dia. flexible connection means from the Continuous Flow Water Heater to the hot water outlet manifold.	HWFC-20
6	Cold water connector	20mm dia. flexible connection means from the Continuous Flow Water Heater to the cold water manifold.	CWFC-20
7	Gas supply connector	20mm dia. Flexible connection means from the Continuous Flow Water Heater to the gas supply inlet manifold.	GSFC-20
8	Hot water outlet isolation valve	System hot water outlet isolating means	HWO-V
9	Cold water inlet isolation valve	System cold water inlet isolating means	CWIN-V
10	Cold water inlet strainer	Protects pump from solids	CWI-S
11	Hot water return isolation valve	Hot water return isolating means	HWR-V
11A	Hot water return strainer	Protects pump from solids	HWR-S
12	Water heater hot water isolation valve	20mm BSP Female ball valve Continuous Flow Water Heater Hot Water isolation means	HWI20BSPF
13	Water heater cold water isolation valve	20mm BSP Female Ball valve Continuous Flow Water Heater cold water isolation means	CWI20BSPF
14	Bi-directional pressure balancing assembly isolation valve	Bi-directional pressure balancing assembly isolation valve supply isolation means Note: In the event of pump failure close valve COMMPAK will operate as per MULTIPAK	BDI32BSPF
15	Water heater gas isolation valve	20MM BSP Female ball valve Continuous Flow Water Heater gas supply isolation means	GSI20BSPF
16	Bi-directional pressure balancing assembly	This assembly performs 3 functions 1/ If hot water outlet pressure is less than cold water inlet pressure (demand exceeds design capability), assembly allows cold water flow from inlet to outlet, to maintain mains water pressure. 2/ If hot water outlet pressure is greater than cold water inlet pressure (Nom. Set 50 kPa) low or no demand condition, assembly allows hot water flow from outlet to inlet, to maintain mains water pressure (+ 50 kPa) 3/ In installations with no return circulation or high resistance, assembly allows hot water to flow from outlet to inlet, to maintain minimum flow requirement for firing of the Continuous Flow Water Heater(s)	BDPBA

COMMPAK PLUS – MAJOR ITEMS LISTING

Refer to photographs (Pages 24 & 25); Major items listings / identification (Pages 26 & 27) and External & Internal Commpak general drawings (Pages 28 & 29)

Item No.	Description	Function	RHEEM Part No's
16A	Bi-directional pressure balancing assembly one way valve	Allows cold water flow from inlet to outlet, to maintain constant pressure.	OWV
16B	Bi-directional pressure balancing assembly regulating valve	Allows hot water flow from outlet to inlet, to maintain constant pressure and minimum flow requirement for firing of the Continuous Flow Water Heater(s) Normally Set: 50-60kPa (Flow and Return Systems) 10kPa (dead leg / no return systems)	RV-32
17	Hot water return one way valve	Prevents reverse flow of cold water into hot water reticulation system.	OWV-32
18	Pressure safety valve	System safety relief valve - 12 Bar operation	PSV-12
19	Plug and gauge cock	Hot water manifold 6mm test point for pressure gauge	PGC-6
19A	Plug and gauge cock	Cold water manifold 6mm Test point for pressure gauge and Isolation means for loss of cold water inlet pressure switch testing (pump/s protection)	PGC-6
20	Continuous Flow Water Heater	Water Heating means. Refer: RHEEM 27 Owner's Guide & Installation Instructions Model 627 Electronic Continuous Flow Gas Water Heater Outdoor - Series 872 & Indoor -Series 862 for further details.	RHEEM Supply Item
20A	External Continuous Flow Water Heater waste gas flue outlet	Recommended 800mm access clearance from flue outlets. Clearance measurements for horizontal flue terminals refer Australian Standard Gas Installations AS5601	
20B	Internal Continuous Flow Water Heater waste gas flue outlet	Refer RHEEM: 'Owners guide and Installation Instructions' <i>Electronic Continuous Flow Gas Indoor Water Heater</i> Series 862 – Models 27 for approved spacing requirements.	
20C	Continuous Flow Water Heater water inlet strainer	Protects the Continuous Flow Water Heater from damage due to ingress of solids. Located on cold water inlet of water heater	
21	Mounting frame	Hot water system mounting frame assembly Refer Commpak general arrangement drawings for full details	MF ASS CE 040 to CE 120
22	Pressure switch and quick fix cable	Pump protection against dry running Pump disabled < 80kPa and re-enabled > 100kPa	WPS+C
23	Pump isolation valve	Pump isolation means	PIV50BSPFM
24	Pump discharge one way valve	Prevents back flow circulation through stationary pump.	POWV50
25	Pump vibration eliminator	Prevent transmission of vibration and noise to the building structure.	PVE
26	Pump rubber in shear (RIS) Mounts	Prevent transmission of vibration and noise to the building structure.	P-RIS
27	Package lifting point	For safe crane lifting and positioning of the package. Refer to lifting instructions on pages 27 & 28	N/A

COMMPAK PLUS EXTERNAL BACK TO BACK – GENERAL ARRANGEMENT

SERVICE CONNECTIONS PROVIDED:

- (1) HOT WATER OUTLET (HWO)
- (2) NATURAL GAS/LPG INLET (GAS)
- (3) COLD WATER INLET (CWI)
- (4) HOT WATER RETURN (HWR)
- (5) PRESSURE RELIEF VALVE OUTLET
- WASTE WATER DRAIN TO TUNDRISH

MODEL	(1) HWO	(2) GAS	(3) CWI	(4) HWR
CP121 – CP128	80	65	80	40
CP129 – CP132	100	65	100	50
CP133 – CP136	100	80	100	50

View AA

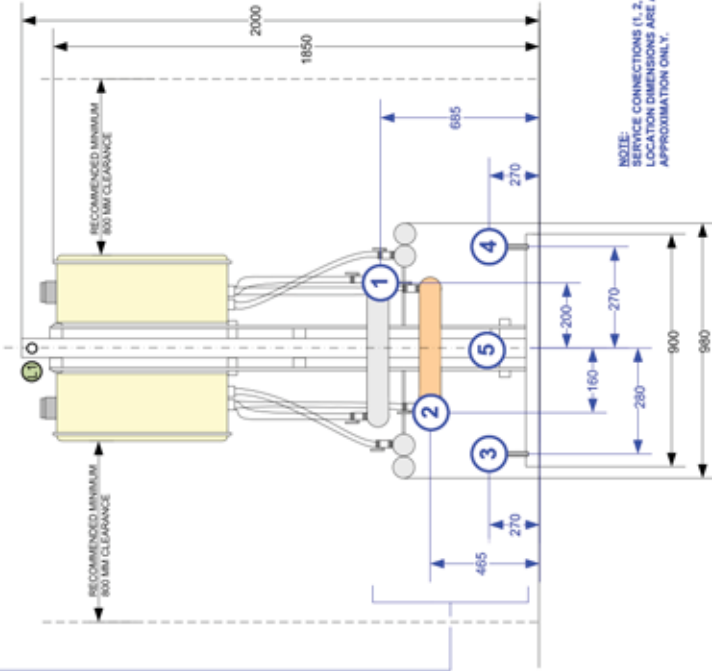

NOTE: SERVICE CONNECTIONS (1, 2, 3, 4 & 5) LOCATION DIMENSIONS ARE AN APPROXIMATION ONLY.

LIFTING INSTRUCTIONS:

- 1. PACKAGE LIFTING: FOUR (4) POINTS LIFTING WITH TWO (2) LIFTING BARS.
- 2. TWO (2) REMOVABLE CIRCULAR HOLLOW STEEL TUBES INSERTED ACROSS THE TOP OF THE UNIT TO PREVENT LIFTING CHAINS FROM SLIPPING OFF THE LIFTING BARS. EDGES FITTED WITH CROSS BOLT TO PREVENT LIFTING CHAINS FROM SLIPPING OFF.
- 3. LIFT TO BE CONDUCTED ONLY WHEN WIND SPEED IS LESS THAN 23 KM/HR. WIND SPEED SHOWN IS A GUIDE ONLY. CRANE CREW TO USE THEIR DISCRETION.
- 4. MAXIMUM HOISTING VELOCITY 1.0M/S.
- 5. CARE SHALL BE TAKEN WHILE LIFTING TO ENSURE LIFTING CHAINS ARE EVENLY LOADED BY GENTLY TAKING THE LOAD TO JUST OFF THE GROUND. EXAMINING AND RETURNING TO GROUND PRIOR TO LIFT.

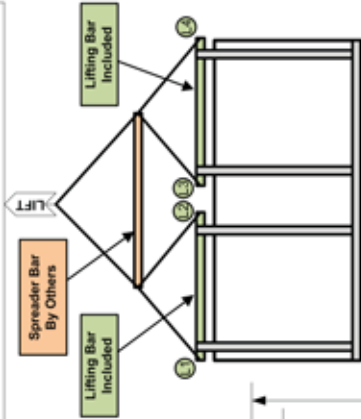

NOTES:

- 1. THIS UNIT IS SUITABLE FOR A FLOW & RETURN OR A DEAD LEG SYSTEM.
- 2. EACH WATER HEATER IS PROVIDED WITH A 240VAC GENERAL PURPOSE POWER OUTLET. EACH PUMP AND ALL POWER OUTLETS ARE PREWIRED TO THE HOT WATER SYSTEM IP54 CONTROL BOX. SUPPLY & INSTALLATION OF 415VAC POWER TO THE CONTROL BOX IS BY OTHERS & SHALL BE IN ACCORDANCE WITH AS/NZS 3000.
- 3. GAS SUPPLY & ALL PLUMBING THEREOF IS BY OTHERS & SHALL BE IN ACCORDANCE WITH AS56601 WITH AS3500.
- 4. WATER SUPPLY TO & FROM & ALL PLUMBING THEREOF IS BY OTHERS & SHALL BE IN ACCORDANCE WITH AS3500.
- 5. ALL DIMENSIONS ARE IN MM UNLESS OTHERWISE STATED.
- 6. HOT WATER SYSTEM SUITABLE FOR INDOOR INSTALLATION ONLY. EACH WATER HEATER TO BE INDIVIDUALLY FLUIDED TO OUTSIDE USING COAXIAL FLUES ONLY.
- 7. SPACING: RECOMMENDED MINIMUM 800MM CLEARANCE FROM THE FRONT OF THE HEATER. RECOMMENDED MINIMUM 1000MM CLEARANCE FROM THE FRONT OF CONTROL PANEL.
- 8. REFER TO INSTALLATION AND OPERATING INSTRUCTION MANUAL FOR ADDITIONAL DETAILS.
- 9. DRAWING SUBJECT TO CHANGE WITHOUT NOTICE.

CPI21 – CPI36

POWER SUPPLY REQUIREMENTS: 415V/3PH/50HZ - FOUR (4) CORE & EARTH (4C&E) PROVIDED : IP54 CONTROL BOX PRE-WIRED TO WATER HEATERS & PUMPS

MODEL	C OR D CURVE UP FRONT PROTECTION
CPI21	20 A
CPI22 – CPI36	25 A

PLAN VIEW

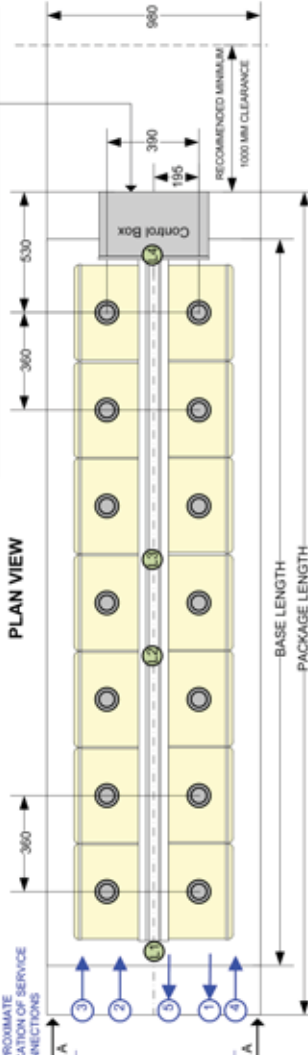

MODEL	BASE LENGTH	PACKAGE LENGTH	WEIGHT KG
CP121	4140	4750	870
CP122	4140	4750	900
CP123	4500	5110	940
CP124	4500	5110	970
CP125	4860	5470	1000
CP126	4860	5470	1040

MODEL	BASE LENGTH	PACKAGE LENGTH	WEIGHT KG
CP127	5220	5830	1070
CP128	5220	5830	1100
CP129	5580	6190	1140
CP130	5580	6190	1170
CP131	5940	6550	1200
CP132	5940	6550	1240

MODEL	BASE LENGTH	PACKAGE LENGTH	WEIGHT KG
CP133	6300	6910	1270
CP134	6300	6910	1300
CP135	6660	7270	1340
CP136	6660	7270	1370

REVISION

NO	DATE	ORIGINAL ISSUE	BY	CHECKED	RHEEM AUSTRALIA PTY LTD
0	07/13		SL	RH	
1	12/13	DIMENSIONAL UPDATES & LIFTING INSTRUCTIONS UPDATES	SL	RH	

DESCRIPTION:

Rheem Commpak Plus CPI21 – CPI36
Commercial Mains Pressure Internal Hot Water System
Back To Back General Arrangement

DESIGNED	DRAWN	DATE	SCALE	DRAWING NO.	REVISION
RH	SL	12/12/13	N.T.S	RCMPAAU21-36	1

REVISION

RHEEM AUSTRALIA PTY LTD
1 Alan Street
Rydalmere NSW 2116
Email : commercialsales@rheem.com.au
www.rheem.com.au

COMPAK PLUS INTERNAL BACK TO BACK – GENERAL ARRANGEMENT

SERVICE CONNECTIONS PROVIDED:

- (1) HOT WATER OUTLET (HWO) FLANGED END TO TABLE E BUTTERFLY VALVE
- (2) NATURAL GAS/LPG INLET (GAS) BSPPT MALE
- (3) COLD WATER INLET (CWI) FLANGED END TO TABLE E BUTTERFLY VALVE
- (4) HOT WATER RETURN (HWR) BSP FEMALE BRASS BALL VALVE/STRAINER COMBINATION
- (5) PRESSURE RELIEF VALVE OUTLET WASTE WATER DRAIN TO TUNDISH

MODEL	(1) HWO	(2) GAS	(3) CWI	(4) HWR
CPE21 – CPE28	80	65	80	40
CPE29 – CPE32	100	65	100	50
CPE33 – CPE36	100	80	100	50

View AA

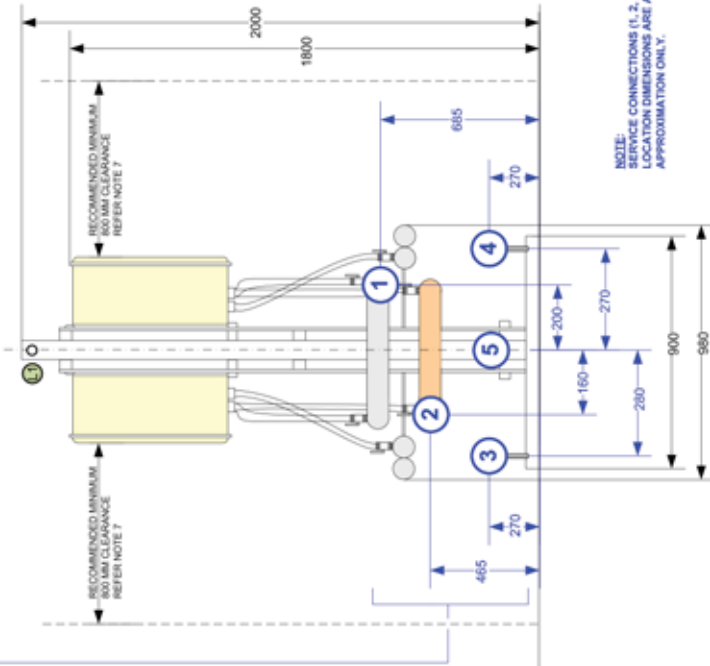

NOTE: SERVICE CONNECTIONS (1, 2, 3, 4 & 5) LOCATION DIMENSIONS ARE AN APPROXIMATION ONLY.

LIFTING INSTRUCTIONS:

- 1. PACKAGE LIFTING: FOUR (4) POINTS LIFTING WITH TWO (2) LIFTING BARS.
- 2. TWO (2) REMOVABLE CIRCULAR HOLLOW STEEL TUBES INSERTED ACROSS THE TOP OF THE UNIT. TWO (2) REMOVABLE LIFTING CHAINS FROM SLIPPING OFF CROSS BACK TO PREVENT LIFTING CHAIN FROM SLIPPING OFF.
- 3. LIFT TO BE CONDUCTED ONLY WHEN WIND SPEED IS LESS THAN 23 KM/HR. WIND SPEED SHOWN IS A GUIDE ONLY. CRANE CREW TO USE THEIR DISCRETION.
- 4. MAXIMUM HOISTING VELOCITY 1.0M/S.
- 5. CARE SHALL BE TAKEN WHILE LIFTING TO ENSURE LIFTING CHAINS ARE EVENLY LOADED BY GENTLY TAKING THE LOAD TO JUST OFF THE GROUND, EXAMINING AND RETURNING TO GROUND PRIOR TO LIFT.

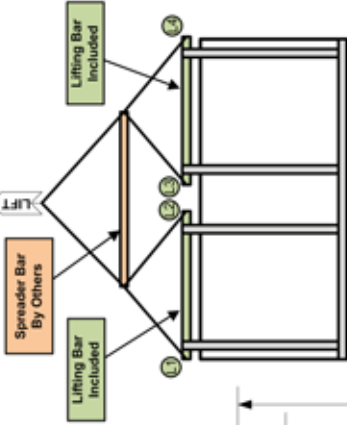

NOTES:

- 1. THIS UNIT IS SUITABLE FOR A FLOW & RETURN OR A DEAD LEG SYSTEM.
- 2. EACH WATER HEATER IS PROVIDED WITH A 240VAC GENERAL PURPOSE POWER OUTLET. EACH PUMP AND ALL POWER OUTLETS ARE PREWIRED TO THE HOT WATER SYSTEM. THE CONTROL BOX SUPPLY & INSTALLATION OF 415VAC POWER TO THE CONTROL BOX IS BY OTHERS & SHALL BE IN ACCORDANCE WITH AS/NZS 3000.
- 3. GAS SUPPLY & ALL PLUMBING THEREOF IS BY OTHERS & SHALL BE IN ACCORDANCE WITH AS5601.
- 4. WATER SUPPLY TO & FROM & ALL PLUMBING THEREOF IS BY OTHERS & SHALL BE IN ACCORDANCE WITH AS3500.
- 5. ALL DIMENSIONS ARE IN MM UNLESS OTHERWISE STATED.
- 6. HOT WATER SYSTEM SUITABLE FOR OUTDOOR INSTALLATION ONLY. RECOMMENDED MINIMUM 1000MM CLEARANCE FROM THE FRONT OF CONTROL PANEL. REFER AS5601-2004 FIG 5.3 FOR MANDATORY REQUIREMENTS.
- 7. SPACING: REFER TO INSTALLATION AND OPERATING INSTRUCTION MANUAL FOR ADDITIONAL DETAILS.
- 8. REFER TO INSTALLATION AND OPERATING INSTRUCTION MANUAL FOR ADDITIONAL DETAILS.
- 9. DRAWING SUBJECT TO CHANGE WITHOUT NOTICE.

CPE21 – CPE36

MODEL	C OR D CURVE UP FRONT PROTECTION
CPE21	20 A
CPE22 – CPE36	25 A

POWER SUPPLY REQUIREMENTS : 415V/3PH/50HZ – FOUR (4) CORE & EARTH (HSAE) PROVIDED : IP65 CONTROL BOX PREWIRED TO WATER HEATERS & PUMPS

PLAN VIEW

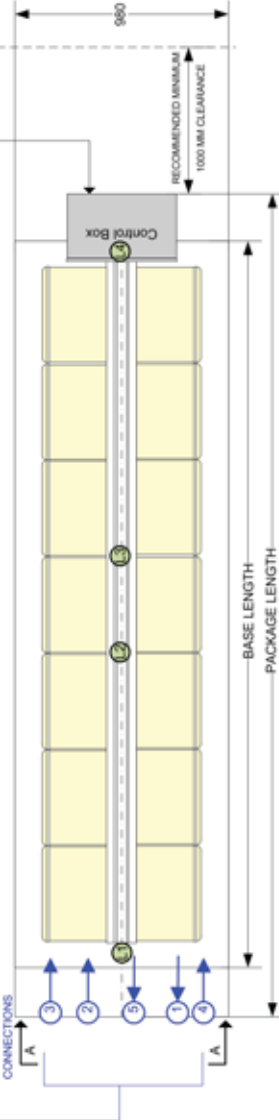

MODEL	BASE LENGTH	PACKAGE LENGTH	WEIGHT KG
CPE33	6300	6910	1270
CPE34	6300	6910	1300
CPE35	6660	7270	1340
CPE36	6660	7270	1370

MODEL	BASE LENGTH	PACKAGE LENGTH	WEIGHT KG
CPE27	5220	5830	1070
CPE28	5220	5830	1100
CPE29	5580	6190	1140
CPE30	5580	6190	1170
CPE31	5940	6550	1200
CPE32	5940	6550	1240

MODEL	BASE LENGTH	PACKAGE LENGTH	WEIGHT KG
CPE21	4140	4750	870
CPE22	4140	4750	900
CPE23	4500	5110	940
CPE24	4500	5110	970
CPE25	4860	5470	1000
CPE26	4860	5470	1040

NO	DATE	REVISION	BY	CHECKED	RHEEM AUSTRALIA PTY LTD	DESCRIPTION:
0	07/13	ORIGINAL ISSUE	SL	RH	RHEEM AUSTRALIA PTY LTD	Rheem Compak Plus CPE21 – CPE36
1	12/13	DIMENSIONAL UPDATES & LIFTING INSTRUCTIONS UPDATES	SL	RH	1 Alan Street Rydalmere NSW 2116 Email : commercialsales@rheem.com.au www.rheem.com.au	Commercial Mains Pressure External Hot Water System Back To Back General Arrangement
					DESIGNED: RH	DRAWING NO: RCP/PAKE-21-36
					DATE: 12/12/13	SCALE: N.T.S.
					REVISION NO: 1	

COMMISSIONING

COMMPAK PLUS – INITIAL CHECKS

Refer to photographs (Pages 24 & 25); Major items listings / identification (Pages 26 & 27) and External & Internal Commpak general drawings (Pages 28 & 29)

1. Check that the power supply to the system controller (Item #1) is switched OFF.
2. Check that an adequate water supply is available to the Commpak hot water system.
Water supply pressure shall not exceed 1000kPa and pressure fluctuation no more than +/- 50 kPa.
3. OPEN cold water inlet valve (Item #9), hot water outlet valve (Item #8) and hot water return valve (Item #11)
Check all individual water heater isolation valves (Items #12 & #13) are OPEN;
Check bi-directional pressure balancing isolation valve (Item #14) is OPEN.
4. Check that the system is fully charged, all the air is bled from the system and no leaks are evident.
Air shall be bled by opening the hot water outlets, pressure relief valve of the hot water system (Item #18) and pump bleed disk (item #5)
5. Check the pipe work for leaks
6. OPEN all individual water heater gas isolation valves (Item #17) and purge gas lines.
7. Check the gas pipe work for leaks

To complete the installation, it is necessary to check the gas supply pressure at the inlet to the water heater (refer to “Gas Inlet Pressure” on page 30), the minimum test point pressure and the maximum test point pressure (refer to page 32).

⚠ Warning: Upon completion of the installation and commissioning of the water heater, leave this guide with the a responsible officer. **DO NOT** leave this guide inside of the cover of the water heater, as it may interfere with the safe operation of the water heater or ignite when the water heater is turned on.

GAS INLET PRESSURE

IMPORTANT - CHECK the gas supply pressure at the inlet to the water heater with the water heater and all other gas burning appliances in the premises operating (burners alight). The minimum gas supply pressure is:

Natural Gas	1.13 kPa	Propane	2.75 kPa
-------------	----------	---------	----------

If this minimum cannot be achieved, it may indicate the meter or the gas line to the water heater is undersized. It is important to ensure that an adequate gas supply pressure is available to the water heater when other gas burning appliances, on the same gas supply, are operating.

GAS INLET TEST POINT PRESSURE

To check the gas inlet pressure, select the CFWH at the furthest point in the manifold as the test unit:

1. Ensure the burners are not operating, by turning off the power to the Commpak.
2. Close the gas isolation valve at the gas inlet to the CFWH.
3. Locate the gas inlet test point on the gas connection to the CFWH.
 - Remove the test point screw and washer from the test point orifice.
 - Connect the manometer.
4. Open the gas isolation valve fully at the gas inlet to the CFWH.
5. Observe the gas pressure reading on the manometer.

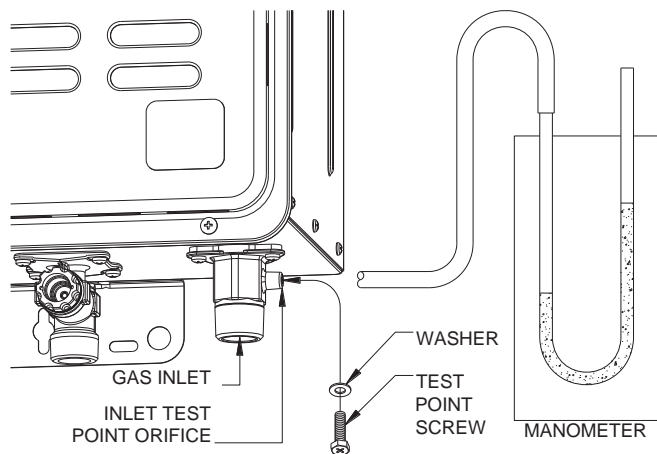

If the manometer reading is between the minimum and maximum inlet gas pressure ratings on the rating label, no adjustment is required.

If the manometer reading is below the minimum inlet gas pressure rating on the rating label, then either the gas pipe to the water heater is undersized and needs to be rectified or adjustment is required at the gas regulator.

If the manometer reading is above the maximum inlet gas pressure ratings on the rating label, then adjustment is required at the gas regulator.

6. Switch on the electrical supply to the Commpak Plus.
7. If installed as part of a recirculation system, the Commpak should start automatically. If on a dead leg system, the unit should start automatically but may shut down before checks are completed. If on a dead leg system open a hot tap fully and ensure all the CFWH are on and the burners are fully ignited. It may be necessary to open several taps.

Note: If the Commpak is using 872627 or 862627 model CFWH and is installed as an in-series gas booster for a solar water heater, then the temperature of the water entering Commpak must be at least 2°C below the water heater preset outlet temperature setting. Otherwise the gas burners will not ignite and the test point gas pressures cannot be measured.

8. Observe the gas pressure reading on the manometer.
 - If the manometer reading is between the minimum and maximum inlet gas pressure ratings on the rating label, no adjustment is required.
 - If the manometer reading is below the minimum inlet gas pressure rating on the rating label, then either the gas pipe to the water heater is undersized and needs to be rectified or adjustment is required at the gas regulator.
 - If the manometer reading is above the maximum inlet gas pressure ratings on the rating label, then adjustment is required at the gas regulator.
9. If an adjustment was made during Step 8, repeat this procedure from Step 5.
10. Close the isolation valve on the outlet of the CFWH.
11. Close the gas isolation valve at the inlet to the CFWH.
12. Remove the manometer and refit and tighten the test point screw and washer.
13. Open the gas isolation valve fully at the gas inlet to the water heater.
14. Open the isolation valve again so the burners ignite.
15. Test for gas leaks.

- Close the hot taps, if open

Warning: The removal of the front panel will expose 240 volt wiring. Take care not to touch wiring terminals.

Note: If the Commpak is using 872627 or 862627 model CFWH and is installed as an in-series gas booster for a solar water heater, then the temperature of the water entering Commpak must be at least 2°C below the water heater preset outlet temperature setting. Otherwise the gas burners will not ignite and the test point gas pressures cannot be measured.

BURNER MINIMUM TEST POINT GAS PRESSURE

Refer to the rating label on the water heater for the minimum test point gas pressure.

- Ensure the burners are not operating, by turning off the power to the CFWH.
- Remove the screws holding the front panel to the jacket.
- Gently disengage the front panel and pull forward to remove from the water heater.
- Locate the burner pressure test point on the main burner manifold.
 - Remove the test point screw and washer from the test point orifice.
 - Connect the manometer.
- Switch on the electrical supply at the power outlet to the water heater.
- Open the gas isolation valve fully at the gas inlet to the water heater, if not already open.
- If installed as part of a recirculation system, the Commpak should start automatically. If on a dead leg system, the unit should start automatically but may shut down before checks are completed. If on a dead leg system open a hot tap fully and ensure all the CFWH are on and the burners are fully ignited. It may be necessary to open several taps.
- Press and hold down the MIN button and observe the reading on the manometer.
 - “1L” is shown on the LED display.
- Release the MIN button.

If the manometer reading observed in step 7 agrees with the rating label, no further adjustment is required.

- To adjust, press and hold the adjuster button.
 - “LH” is shown on the LED display.

Note: The adjuster button must be held down continuously through steps 10 to 12.

- Press and hold the MIN button and observe the reading on the manometer.
 - The manometer reading will change as the test point gas pressure adjusts.

Note: While the MIN button is pressed, the gas pressure will at first increase then decrease, cycling between an upper gas pressure limit (39 on the LED display) and a lower gas pressure limit (01 on the LED display).

- Release the MIN button when the reading on the manometer agrees with the rating label. Release the adjuster button.

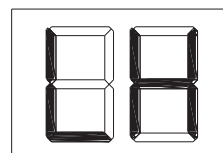
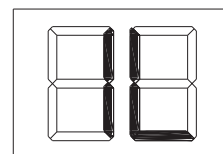
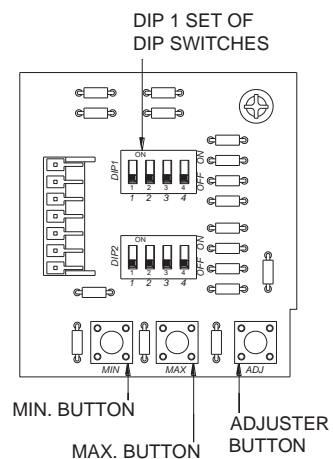
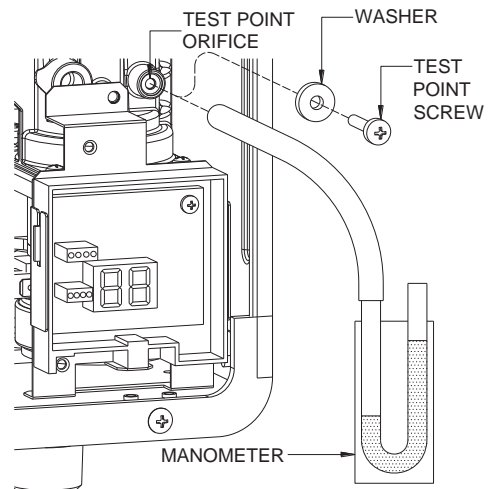

Notes:

- If the burners extinguish and error code 11 or 12 starts to flash on the LED display:
 - release the MIN and adjuster buttons
 - close the CFWH isolation valve
 - clear the error code (refer to “Clearing Error Code” on page 33)
 - recommence the procedure from Step 7
- If the adjuster button is released before Step 12, clear any error code (if displayed) and recommence the procedure from Step 7.

BURNER MAXIMUM TEST POINT GAS PRESSURE

Refer to the rating label on the water heater for the maximum test point gas pressure.

Follow Steps 7 to 12 of the “Minimum test point gas pressure” procedure on page 32, but open the hot tap fully and use the MAX button instead of the MIN button. It may be necessary to open two or three hot taps fully, depending upon the model of water heater and the incoming cold water temperature.

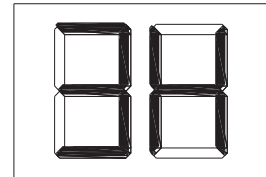

Note: In Step 7, “3H” (627 models) will be shown on the LED display.

After setting the minimum and maximum test point gas pressures:

- Close the outlet isolation valve.
- Remove the manometer and refit and tighten the test point screw and washer.
- Open the isolation valve again so the burners ignite.
- Test for gas leaks..
- Refit the front panel and screws to the water heater.

CLEARING ERROR CODE

If an error code does appear on the LED display during the commissioning process, it will be necessary to clear the error in order to complete the installation.

To clear an error code:

- switch off the electrical supply at the power outlet to the water heater
- check the gas isolation valve at the gas inlet to the water heater is fully open
- wait five (5) minutes
- switch on the electrical supply at the power outlet to the water heater

NOTE: If min/max pressure adjustments were required on the test heater it may be necessary to test all water heaters individually.

PRESET OUTLET TEMPERATURE SETTING

The factory preset outlet temperature setting of the water heater is:

- 70°C as part of a Commpak system

It is usually not necessary to check or adjust the factory preset outlet temperature setting of the water heater, unless the customer or application has a particular requirement for this to be done.

For applications requiring sanitising temperatures, such as a commercial kitchen, it will be necessary to adjust the preset outlet temperature setting and controller to 82°C. Refer to page 34 for details.

If the water heater is installed as part of a circulated hot water flow and return system in a building, the preset outlet temperature setting must be set to at least 60°C. If the water temperature decreases by more than 5°C through a circulated hot water flow and return system due to heat loss in the ring main, the preset outlet temperature setting of the water heater should be set to at least 65°C.

GAS BOOSTER FOR A SOLAR WATER HEATER

Note: AS 3498 requires that a water heater provides the means to inhibit the growth of Legionella bacteria in potable water. When this water heater is used as an in-series booster for a solar water heater it can satisfy this AS 3498 requirement provided it is energised and the booster preset outlet temperature setting is 70°C or higher.

It will be necessary to check and if required to adjust the preset outlet temperature setting of the continuous flow water heater when:

- it is installed as an in-series gas booster to a solar water heater
- it is an existing continuous flow water heater and a solar water heater is then installed.

Note

- Consideration must be given to the delivery temperature to any ablution and public areas such as a bathroom, ensuite or public amenities. Refer to “Hot Water Delivery” on page 20

TO CHECK OR ADJUST THE PRESET OUTLET TEMPERATURE SETTING

The temperature settings will be displayed on the LED display. The preset outlet temperature settings are:

- 872/862 series 38°C, 40°C, 42°C, 43°C, 45°C, 50°C, 55°C, 60°C, 65°C, 70°C, 75°C, 82°C

It is necessary to have the electrical supply to the water heater switched on during stages of checking or adjusting the preset outlet temperature setting procedure.

⚠ Warning: The removal of the front panel will expose 240 volt wiring. Take care not to touch wiring terminals. The adjustment must be carried out by a qualified person.

⚠ Warning: This procedure will involve the adjustment of dip switches. Adjustment of a dip switch should only be made with an insulated tool.

To check or adjust the preset outlet temperature setting:

1. Switch off the electrical supply at the power outlet to the water heater.
2. Remove the screws holding the front panel to the jacket.
3. Gently disengage the front panel and pull forward to remove from the water heater.
4. Switch on the electrical supply at the power outlet to the water heater.
5. Switch dip switches 3 and 4 to the on (up) position on the DIP 1 set of DIP switches on the I.C. Board.

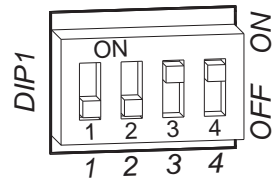

The current preset outlet temperature setting will show on the LED display.

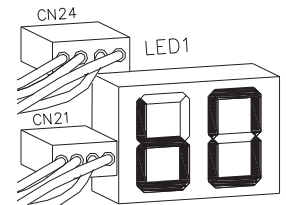

If the temperature displayed on the LED display is the desired preset outlet temperature setting, then proceed to step 7, as no further adjustment is necessary.

6. Press the MAX button to increase or the MIN button to decrease the preset outlet temperature setting.

Each press of the MAX or MIN button will increase or decrease the preset temperature by one increment.

The MAX and MIN buttons are located underneath the DIP 1 and DIP 2 set of DIP switches.

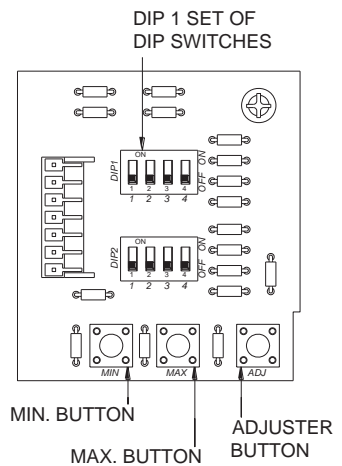

872 series

The increments are 38, 40, 42, 43, 45, 50, 55, 60, 65, 70, 75, 82.

Set the LED display to 82 on an 872 series water heater if it is required to deliver sanitising temperatures.

7. Switch dip switches 3 and 4 to the off (down) position.
The LED display will go blank. The preset outlet temperature setting is now set.
8. Switch off the electrical supply at the power outlet to the water heater.
9. Refit the front panel and screws to the water heater.

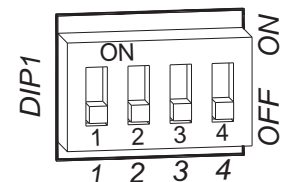

TO TURN OFF THE WATER HEATER

If it is necessary to turn off the water heater on completion of the installation, such as on a building site or where the premises is vacant, then:

- Switch off the electrical supply at the isolating switch to the Commpak (refer to note below).
- Close the gas isolation valve at the inlet to the Commpak.
- Close the cold water, hot water flow and building return isolation valves at the inlet to the Commpak.
- Drain each CFWH if there is a risk of freezing conditions occurring (refer to “[Draining the Water Heater](#)” on page 36).

Notes:

- The frost protection system will be rendered inoperable if electrical power is not available at the water heater.
- Damage caused by freezing due to the unavailability of power at the water heater is not covered by the Rheem warranty (refer to “[Terms of the Rheem Warranty](#)” on page 75).
- If the power has been switched off to the water heater and there is a risk of freezing, then it is necessary to drain the water heater (refer to “[Draining the Water Heater](#)” on page 36).

DRAINING THE WATER HEATER

To drain the water heater:

- Turn off the water heater (refer to “[Turn off the Water Heater](#)” on page 36).
- Open the pressure relief valve on the Commpak located on the hot manifold.
- Unscrew the two drain plugs, one each at the cold water inlet and hot water outlet, on the underside of each continuous flow water heater.

Water will drain from the water heaters.

- When water stops flowing from the water heaters, close the pressure relief valve.

Note: It is recommended not to screw the drain plugs back in, until the water heater is to be turned on again.

COMMPAK PLUS – START-UP CHECKS

System Pumps Warning: Dry running of the Pumps will result in permanent damage and is not covered under warranty

1. Before turning 415VAC power on to the hot water system controller ensure the following checks are undertaken.

Please ensure incoming power supply is connected to provide clockwise rotation. Failure to do so will cause the pumps to run backwards.

2. Check individual water heater (Item #20) power supply leads are plugged in (Item #2) and turned ON
3. Turn on the power supply to the hot water system controller (Item #1)
Check hot water system controller status (as displayed on the control module) (Item #1)
LCD display is ON and Pump Run LED(s) are illuminated.
Refer to hot water system controller insert (pages 56-73) for additional details.
4. Check all water heaters (Item #20) have fired and are operational
Note: All hot water units have been factory tested, temperature pre-set and gas pressures adjusted and as such no further adjustments are required.
5. Check hot water outlet temperature display (Item #1) registers a temperature rise.

Turn on several hot water outlets (fixtures) on the installation to check that all the individual water heaters and pumps are operating correctly.

6. When satisfied, CLOSE hot water outlet isolation valve (item #8)
Depress the 'RESET' button on the hot water system control module (item #1) and hold ON for 5 seconds.
This will enable both the hot water outlet temperature (T2) and the return water temperature (T1) to be displayed simultaneously.
The Pump will turn OFF when return temperature (T1) has reached 60°C (nominal default value).
Re OPEN hot water outlet isolation valve (item #8) pump will restart and CFHW units will fire.
Leave running until satisfied with operation.

COMMISSIONING - FINAL CHECKS

1. Test and confirm pumps loss of water protection pressure switch (Item #22 & Item # 19A):
 - a. Close the isolating valve to the pressure switch during the normal operation of the hot water system. Undo the bleed/test plug to relieve the pressure. This will initiate the pumps shut down timer (user programmable) nominally set at 15 seconds. Check and confirm pumps are locked-out on time out.
 - b. Screw back in the bleed/test plug and open the isolation valve to the pressure switch. This will re-instate operation of pumps. Check and confirm this on the controller.

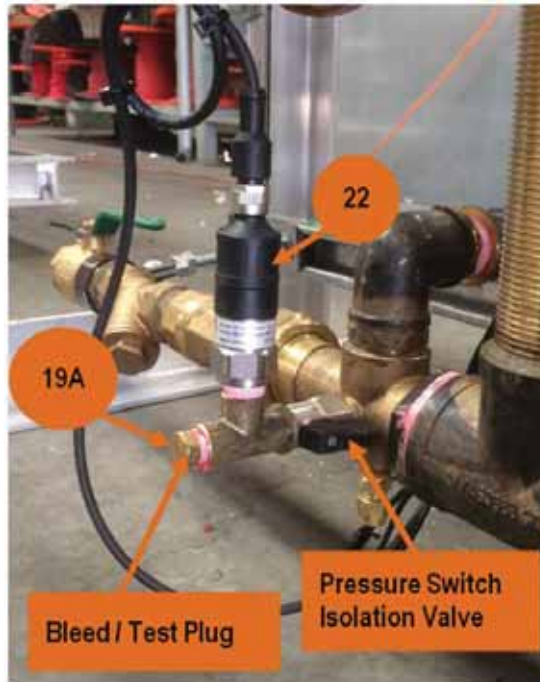

2. Check system for any leaks (gas and water)
3. Turn system 415VAC power OFF (Item #1). Isolate main water valves (Items #8; #9 & #11); check and clean the inline cold water supply strainer; hot water return water strainer and individual water heater strainers (Items #10; #11A & #20C).
4. Advise customer to check strainers after 1 week usage. Continue to check strainers on a weekly basis until they inspect clean. Continue to check strainers on a monthly basis until they inspect clean. Continue to check strainers on a quarterly basis until they inspect clean. Thereafter check every six (6) months.
5. Re-instate Commpak by repeating steps 2 to 7
6. Fill in commissioning sheet (page 40).
7. 'Rheem Commpak commercial continuous hot water heater' can now be left on line.

Finish.

CP21-CP36: Fault Finding Procedure		
Fault	Possible Causes	Description and Recommended Corrective Action
Hot Water System not operating	Power Failure	<p>Check system Controller – Is the LCD Temperature Display ON</p> <ul style="list-style-type: none"> No Check controller isolator is turned ON If not turn switch to the ON position Note: The water heater GPO's are earth leakage (safety switch) protected and will trip(turn OFF) if an earth fault of 30ma or greater is present. If tripped unplug all leads from their power outlets, reset tripped breaker. If breaker does not trip? - Plug in each power lead one at a time until breaker trips – leave offending item unplugged and report to supplier. Check 415VAC Supply from distribution board powering Controller Is ON If tripped? Check circuit breaker rating is equivalent to the nominated. Refer page 5 Electrical Installation – Power Supply. Yes LCD Temperature Display is ON Power OK Contact supplier for additional assistance.
	Controller Fault	<p>Check system Controller – Are any Fault LEDs illuminated</p> <ul style="list-style-type: none"> Yes Faulty T1 or T2 Sensor LED Illuminated Check connections are good and no breaks in cable. If Good? Sensor is faulty, replace sensor Yes High Temperature LED Illuminated Check actual water temperature and compare against controller displayed value. If displayed value is incorrect replace T2 sensor If same? Check high temp setting (refer page 69) set value If setting value correct? = Faulty CFWH or incorrect setting Refer CFWH manual for details Yes Low Temp Fault LED Illuminated Check all strainers are clear Check pump is ON and operating Check gas pressure is OK Yes Pump Lock-out LED Illuminated Check water supply is turned on Check pump is On and operational Check pressure Switch (item 22) contacts are open Check gas supply is ON and correct pressure <p>NOTE: Controller RESET button will clear any latched fault. Refer System Controller Pages 56-73 for additional information</p> <p>NOTE If System Controller is faulty <i>Turn Pump 1 and or Pump 2 'Auto – Off – Man selector switch to "Man" Selected pump(s) will run to provide hot water out and return circulation. System will continue to operate until Controller can be replaced</i> Contact your supplier for additional assistance.</p>
	Pump Fault	<p>If Pump 1 or Pump 2 Fault LED is ON? Operation will automatically transfer to the healthy pump Reinstate the faulty pump motor protection device 'P1MS or P2MS' by rotating its function switch from "O" to "I". Should the protective device re-trip to the "O" position? Leave off and contact your supplier for additional assistance. Refer Pump Manual Pages 40-54 for additional pump information</p>
	CFWH Fault	<p>Refer to RHEEM Owner's Guide and Installation Instructions for additional Information</p>

Note:

CFWH = Continuous Flow Water Heater

CP21-CP36: Commissioning Sheet		
Customer :		
Project and Address:		
Package Details:		
Installation	OK	Comments
Overall Installation?		
Installation Requirements: Individual Water Heaters Co-axial Flueing		Compliance to AS5601 is mandatory Refer: RHEEM Owner’s Guide & Installation Instructions Models 627 Continuous Flow Gas Outdoor Water Heater 872 Series Continuous Flow Gas Indoor Water Heater 862 Series
Ventilation Requirements?		Compliance to AS5601 is mandatory
Fuel: Natural Gas/LPG		
Gas Pressure During full Load Operation?		Natural Gas: 1.13 Minimum & Up to 3.5 kPa Propane: 2.75 Minimum & Up to 3.5 kPa
Inlet Water Pressure		
Inlet Water Pressure?		Minimum 150 kPa & up to 1000 kPa
Inlet Water Pressure		
Inlet Water Pressure?		Minimum 150 kPa & up to 1000 kPa
Valves		
All the Valves are in Open Position?		
Differential Bypass Valve Position?		Flow and Return System: Set to No. 6 Dead Leg System: Set to No. 1
Pressure Safety Valve Operation?		
Pumps		
Operation?		Please ensure incoming power supply is connected to provide clockwise rotation. Failure to do so will cause the pumps to run backwards.
Package Controller (In accordance to system controller – Test Sheet – Refer to pages 69-70)		
Set Temperature Reached?		
Check Indicators?		
Overall Operation?		
Pumps		
Flow and Return System or Dead Leg System?		
All Water Heater Operations?		
System Temperature Reached and Pump/s Shutdown?		
Differential Bypass Valve Operation?		Simulate both Flow/Return or Dead Leg Systems
Comments		
Client to carry out regular preventative maintenance as below: Pump Inlet Strainer; Hot Water Return Strainer and Water Heaters Inlet Strainers: Check and Clean as per the schedule – Refer Clauses 3 & 4 of Page 38-Commissioning – Final Checks		
Sign Off		
System Commissioned By:		Customer’s Representative:
Date:		Date:

FEATURES & APPLICATIONS



Note: 65-250 & 80mm models have precision cast 316 s/s casings.

These series of stainless steel pumps feature a unique one piece volute casing that are produced using an advanced computer controlled plasma stamping system that ensures total quality control during manufacture (up to 65-200/22). With the smooth surfaces of stamped stainless steel, this results in consistent high standard products, of superior quality and high efficiency.

Features

- Stainless steel liquid end components
 - High quality; corrosion resistance.
 - Manufactured in Stamped 316L and Cast 316 in larger models.
- High quality mechanical shaft seals and o-rings
 - Fitted standard with SiC/SiC/Miton mechanical seal.
- Standard IEC motors used
 - Allowing for single phase, special enclosure, or specific brand motors to be fitted.
- Close coupled design
 - Saves space; simplifies maintenance and installation.
- Back pullout construction
 - Assembly and overhaul of the impeller and seal without disturbing suction and discharge connections.
- High operating efficiency
 - Lowers operating costs.
- Top centerline discharge and foot support under casing
 - Ensures self-venting and reduces misalignment from pipe loads.
- Available in "Kit" form
 - "Kit" consists of complete pump wet end, cast iron motor bracket, stub shaft, motor support and all fasteners.



Applications

- Plant services
- Water supply systems
- Washing plants
- Cooling water
- Ultrapure water systems
- Air conditioning
- Sprinkler/flow irrigation
- OEM equipment application
- Pressure boosting
- Liquid transfer
- Heat exchanger
- Spray systems
- Heating
- Beverage processing
- Pharmaceutical services
- Water reclamation and treatment

TYPICAL CROSS SECTIONAL VIEW

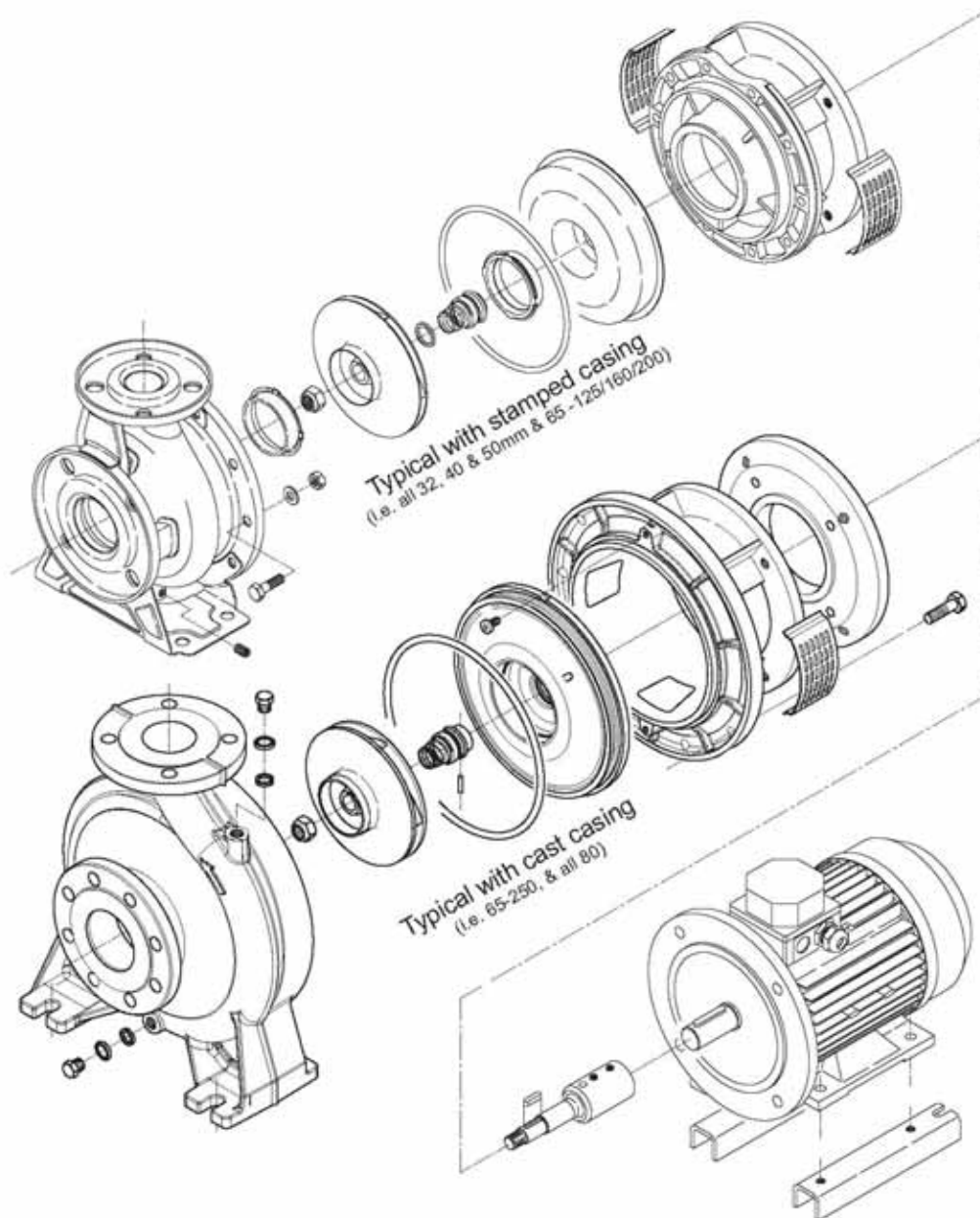

PUMP SPECIFICATIONS

V09

Liquid Handled	Type of Liquid		Clean water & moderately aggressive fluids			
	Liquid Temperature		Minimum -10°C to Maximum 110°C			
Maximum Working Pressure		1 MPa				
Construction	Impeller	32,40,50 mm models	Closed centrifugal type (welded)			
		65,80 mm models	[Reinforced laser welding for 40-200/1.5 & 50-200/2.2] Closed 3 dimensional centrifugal Type (cast)			
Bearings		Sealed Ball Bearing				
Pipe Connections	Discharge x Suction	32-160/200	32 mm	x	50 mm	
		40-125/160/200	40 mm	x	65 mm	
		50-125/160/200	50 mm	x	65 mm	
		65-125/160/200/250	65 mm	x	80 mm	
		80-160/200/250	80 mm	x	100 mm	
					All flanged to DIN 2532 standard	
Materials	Casing	All 32, 40 & 50 65-125/160/200	AISI 316 L Stainless Steel (stamped) [EN 1.4404]			
		65-250 All 80	AISI 316 Stainless Steel (precision cast) [EN 1.4401]			
	Impeller	All 32, 40 & 50	AISI 316 L Stainless Steel (stamped) [EN 1.4404]			
		All 65 & 80	AISI 316 Stainless Steel (precision cast) [EN 1.4401]			
	Casing Cover	All 32, 40 & 50 65-125/160/200 80-160	AISI 316 L Stainless Steel (stamped) [EN 1.4404]			
		65-250 80-200/250	AISI 316 Stainless Steel (precision cast) [EN 1.4401]			
	O-ring (casing)		FPM [Viton]			
	Mechanical Seal (@ start diameter)	All 32, 40 & 50 65 up to 11 kW	1.1~15 kW 4.0~11 kW	22mmØ	SiC/SiC/FPM [Viton] with anti rotation device for stationary seat.	
		65 -160/200/250 80-160/200/250	15~37 kW 11~37 kW	30mmØ		
	Stub Shaft (@ diameter at impeller)	All 32, 40, 50 up to 1.5 kW 65-160/200	0.25~1.5 kW 0.55~3.0 kW	19mmØ	AISI 316 Stainless Steel [EN 1.4404]	
		50-200/2.2 80-160	2.2 kW 1.5~2.2 kW	22mmØ		
		65 -250 80-200/250	3~5.5 kW 3~7.5 kW	24mmØ		
Bracket		Cast Iron (& Aluminum depending on motor used)				



MOTOR SPECIFICATIONS

Version	3LS4
Type	Electric-TEFC Three phase
No.of Poles	4
Rotation speed [min ⁻¹]	~1400
Insulation class	F (class B for temperature rise)
Protection degree	IP 55
Power rating [kW]	0.25 ÷ 7.5
[HP]	0.33 ÷ 10
Frequency [HZ]	50
Voltage [V]	220÷240 / 380÷415 ±5% (up to 4.0 kW) 380÷415 / 660÷720 ±5% (5.5 kW and above)
Casing material	Cast Iron
Dimensions of cable entry	- M20x1.5 - M25x1.5 - M32x1.5
Flange mount (IEC motor)	IM B5 (up to 1.5 kW) IM B35 (2.2 kw and above)

Note : Specifications refer to Standard motors.
WEG motors are generally used, but
other brands and types are available.

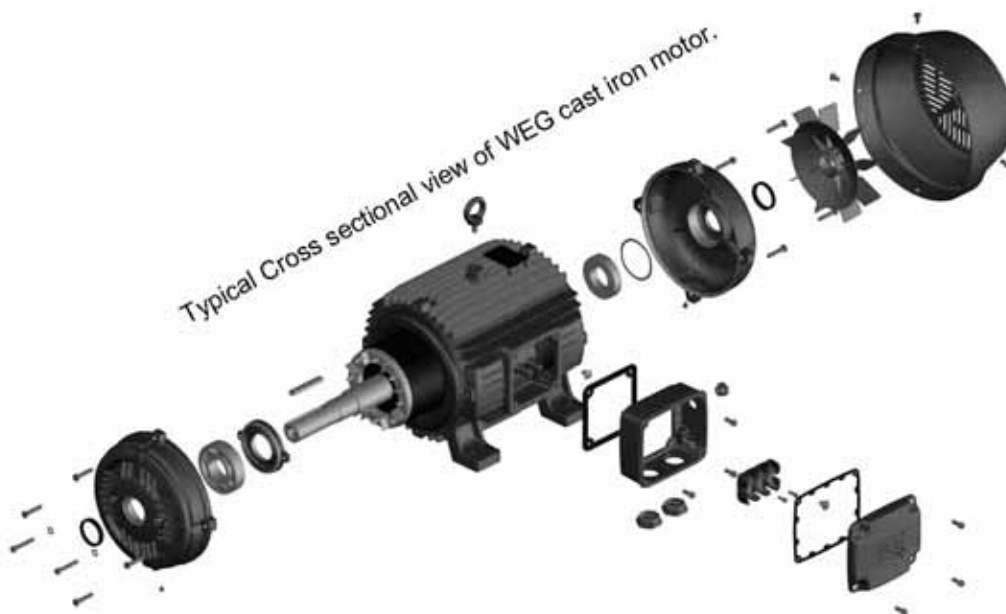

DIMENSIONS 3LS4 40

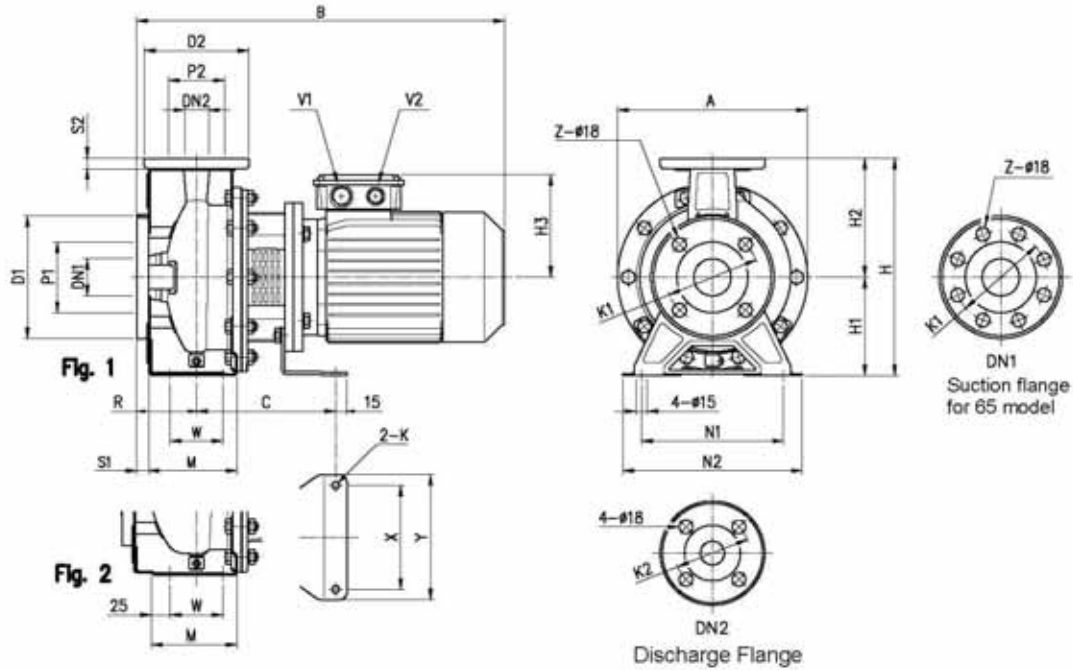

Note : Weight and some Motor dimensions may vary depending on motor fitted

Model	Dimensions (mm)																							Weight [kg]						
	∅ DN1	∅ P1	∅ K1	∅ D1	S1	Z	∅ DN2	∅ P2	∅ K2	∅ D2	S2	Fig	H	H1	H2	H3	R	W	M	N1	N2	A	B		C	X	V	K	V1	V2
32-125/0.35	50	95	125	165	18	4	32	75	100	140	14	1	252	112	140	112	85	70	114	140	180	213	403	553	112	140	8	M20x1.5	M16x1.5	18.5
32-180/0.37R	50	95	125	165	18	4	32	75	100	140	14	1	292	132	160	112	85	70	118	190	240	254	403	553	112	140	8	M20x1.5	M16x1.5	18.5
32-180/0.37	50	95	125	165	18	4	32	75	100	140	14	1	292	132	160	112	85	70	118	190	240	254	403	553	112	140	8	M20x1.5	M16x1.5	18.5
32-200/0.55R	50	95	125	165	18	4	32	75	100	140	14	1	340	160	180	128	85	70	118	190	240	296	430	574	140	188	10	M25x1.5	M20x1.5	28
32-200/0.55	50	95	125	165	18	4	32	75	100	140	14	1	340	160	180	128	85	70	118	190	240	296	430	574	140	188	10	M25x1.5	M20x1.5	28
32-200/0.75	50	95	125	165	18	4	32	75	100	140	14	1	340	160	180	128	85	70	118	190	240	296	430	574	140	188	10	M25x1.5	M20x1.5	28.5
40-125/0.37R	85	115	145	185	18	4	40	80	110	150	14	1	252	112	140	112	80	70	114	180	210	213	403	553	112	140	8	M20x1.5	M16x1.5	18
40-125/0.37	85	115	145	185	18	4	40	80	110	150	14	1	252	112	140	112	80	70	114	180	210	213	403	553	112	140	8	M20x1.5	M16x1.5	18
40-180/0.55R	85	115	145	185	18	4	40	80	110	150	14	1	292	132	160	128	80	70	118	190	240	254	430	574	140	188	10	M25x1.5	M20x1.5	23.8
40-180/0.55	85	115	145	185	18	4	40	80	110	150	14	1	292	132	160	128	80	70	118	190	240	254	430	574	140	188	10	M25x1.5	M20x1.5	23.5
40-200/1.1R	85	115	145	185	18	4	40	80	110	150	14	2	340	160	180	138	100	70	115	212	265	296	497	596	140	188	10	M25x1.5	M20x1.5	34.8
40-200/1.1	85	115	145	185	18	4	40	80	110	150	14	2	340	160	180	138	100	70	115	212	265	296	497	596	140	188	10	M25x1.5	M20x1.5	34.5
40-200/1.5	85	115	145	185	18	4	40	80	110	150	14	2	340	160	180	138	100	70	115	212	265	296	497	596	140	188	10	M25x1.5	M20x1.5	35.5
50-125/0.55R	85	115	145	185	18	4	50	95	125	165	18	2	292	132	160	128	100	70	114	190	240	254	450	574	140	188	10	M25x1.5	M20x1.5	23.5
50-125/0.55	85	115	145	185	18	4	50	95	125	165	18	2	292	132	160	128	100	70	114	190	240	254	450	574	140	188	10	M25x1.5	M20x1.5	23.5
50-180/1.1R	85	115	145	185	18	4	50	95	125	165	18	2	340	160	180	138	100	70	115	212	265	296	497	596	140	188	10	M25x1.5	M20x1.5	34
50-180/1.1	85	115	145	185	18	4	50	95	125	165	18	2	340	160	180	138	100	70	115	212	265	296	497	596	140	188	10	M25x1.5	M20x1.5	34
50-200/1.5R	85	115	145	185	18	4	50	95	125	165	18	2	380	180	200	138	100	70	115	212	265	296	497	596	140	188	10	M25x1.5	M20x1.5	37
50-200/1.5	85	115	145	185	18	4	50	95	125	165	18	2	380	180	200	138	100	70	115	212	265	296	497	596	140	188	10	M25x1.5	M20x1.5	37
65-125/0.55	80	134	160	200	18	8	65	115	145	185	18	2	340	160	180	128	100	95	140	212	280	254	490	574	140	188	10	M25x1.5	M20x1.5	21.5
65-125/0.75	80	134	160	200	18	8	65	115	145	185	18	2	340	160	180	128	100	95	140	212	280	254	490	574	140	188	10	M25x1.5	M20x1.5	23
65-125/1.1	80	134	160	200	18	8	65	115	145	185	18	2	340	160	180	128	100	95	140	212	280	254	497	596	140	188	10	M25x1.5	M20x1.5	22
65-180/1.5	80	134	160	200	18	8	65	115	145	185	18	2	380	180	200	138	100	95	140	212	280	296	497	596	140	188	10	M25x1.5	M20x1.5	37

PERFORMANCE CURVE

40-200/1.1 (1.1kW) – impeller diameter = 200 mm

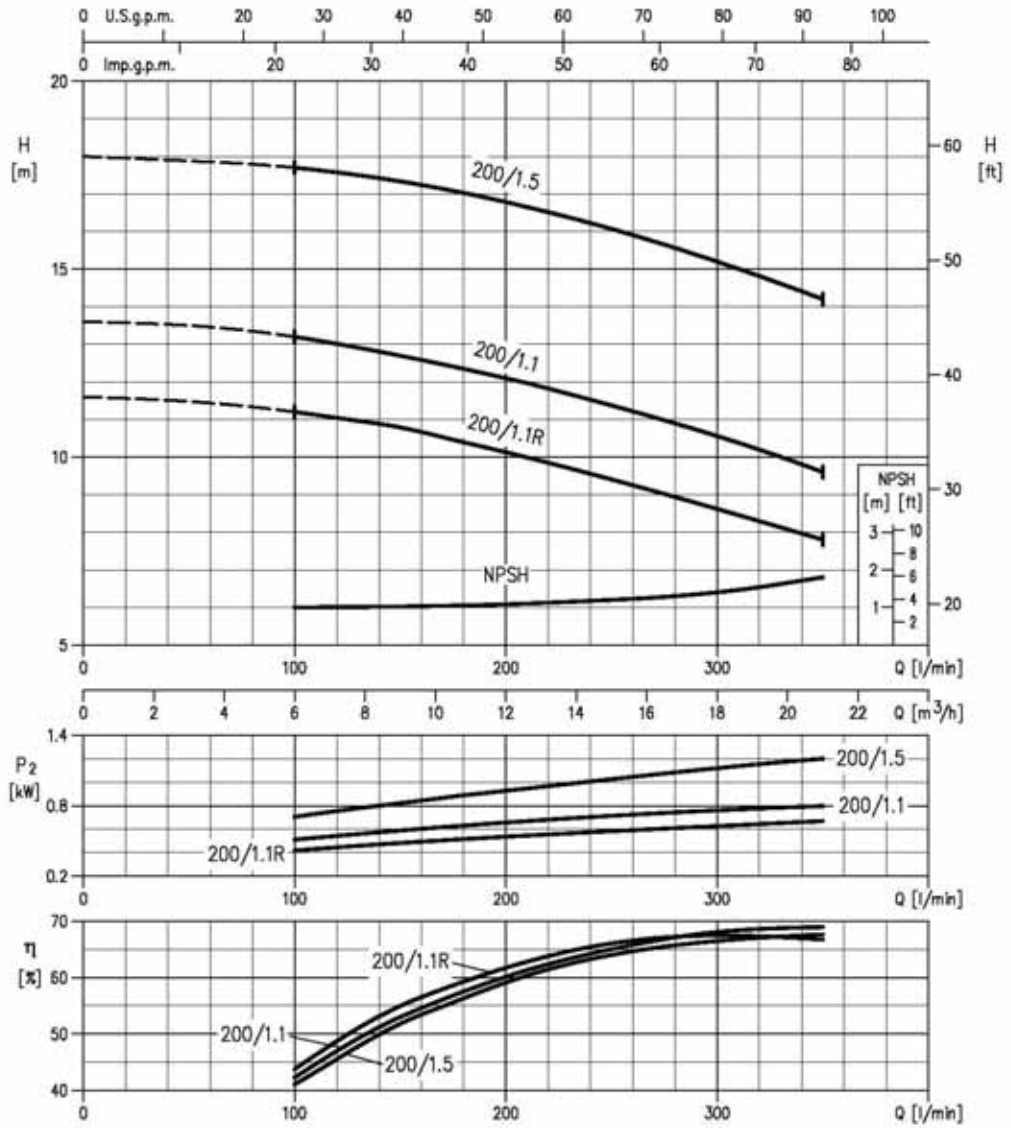

Rotation speed ≈ 1400 min⁻¹ Test standard : ISO 9906 Annex A

CONSTRUCTIONS 3LS4 40

N°	PART NAME	MATERIAL	DIMENSIONS	STANDARD	N. FOR 1 UNIT
3LS4					
001	Casing	EN 1.4404 (AISI 316L)			1
003	Motor bracket	Cast iron EN-G.L-200-EN 1561			1
004	Casing cover	EN 1.4404 (AISI 316L)			1
006	Coupling - Part in contact with liquid	EN 1.4404 (AISI 316L)	See table p. 326		1
007	Impeller 32, 40, 50 65-125/160/200	EN 1.4404 (AISI 316L) EN 1.4401 (AISI 316)			1
011	Mechanical seal	SiC/SiC/PPM	See p. 321-325		1
012	Motor	-			1
025	O-ring plug	EN 1.4401 (AISI 316) / PTFE	R 1/8" L=8	DN 906	1
026	O-ring 32-125, 40-125 32-160, 40-160, 50-125, 65-125 32-200, 40-200, 50-160, 50-200, 65-160, 65-200	PPM	158 11x5.34	OR 6625	1
			183.52x5.34	OR 6720	
			227.96x5.34	OR 6895	
032	Key	EN 1.4401 (AISI 316)	6x6x25	UNI 6004	1
034	Impeller nut: Other model 50-200/2.2	EN 1.4404 (AISI 316L)	M16x1.5 M18x1.5	UNI 7474	1
042	Flot	Zinc-coated steel			[1]
044	Protection	EN 1.4301 (AISI 304)		EBARA DRAWING	2
072	Casing ring (not for 65 version) [2]	EN 1.4404 (AISI 316L)			1
073	Casing ring (not for 65 version)	EN 1.4404 (AISI 316L)			1
200	Screw 32-125, 40-125 40-160, 40-200, 50-125, 50-160, 50-200, 65-125, 65-160, 65-200	Stainless steel A2 70 class ISO 3506/1	M 8x30	UNI 5739	8
			M 10x35	UNI 5739	[3]
			M 8x20		
206	Screw up to 0.37kW from 0.55 to 1.5kW for 2.2 and 3kW	Zn. Steel 8.8 strength class ISO 898/1	M 10x25	UNI 5739	4
			M 12x30		

[1] N° for 1 unit=1 up to 1.5kW N° for 1 unit=2 for 2.2 and 3kW

[2] Only for version 32-200, 40-200, 50-160, 50-200

[3] N° for 1 unit=10 for 32-160, 40-160, 50-125, 65-125

N° for 1 unit=12 for 32-200, 40-200, 50-160, 50-200, 65-160, 65-200

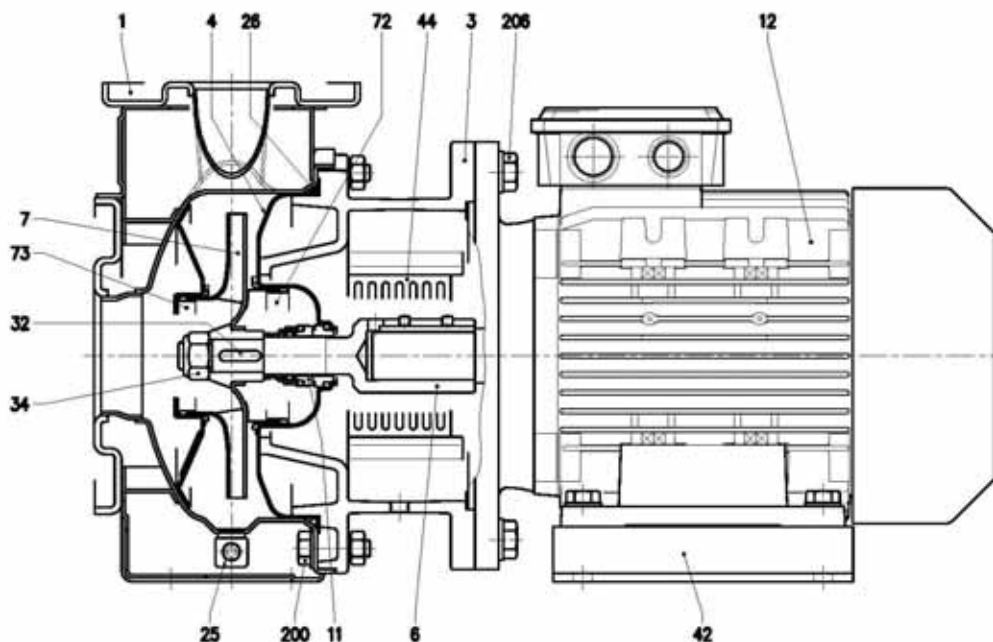

CONSTRUCTIONS - MECHANICAL SEAL

MECHANICAL FOR SEAL L VERSION Ø22

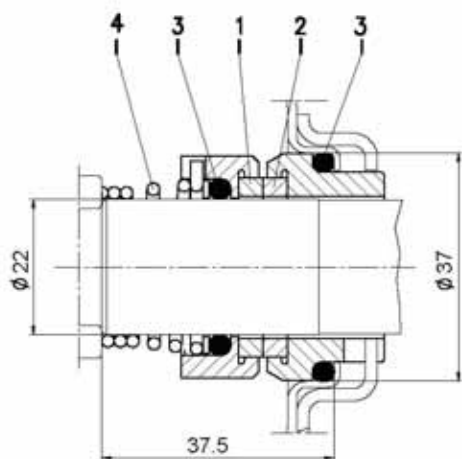

Fig. A

MECHANICAL SEAL FOR L VERSION Ø30

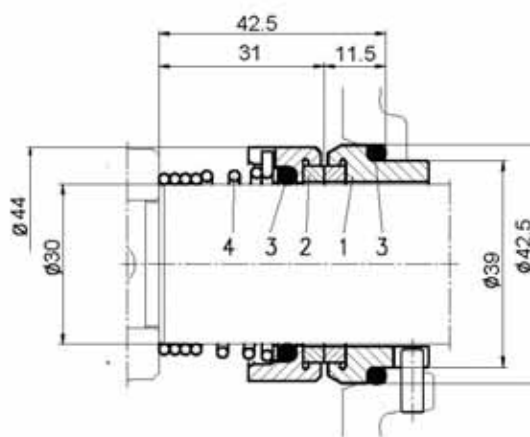

Fig. B

Fig.	Manufacturer Reference			Pump type	Material			
	Manuf.	Description	Material Description		1 Stationary seal ring	2 Rotary seal ring	3 rubber	4 Frame + spring
A	Burgmann	M377GN85/22-00-R	Q1Q1VGG	32-125/160/200 40-125/160/200 50-125/160/200 65-125/160/200 80-160	SiC	SiC	FPM	EN 1.4571 (AISI 316Ti)
B		M377GN85-R		65-250 80-200/250				

**INSTRUCTION MANUAL REGARDING USE AND MAINTENANCE
PART 1
TO BE KEPT BY THE USER**

1. INTRODUCTION

This instruction manual is made up of two parts: PART 1 which contains general information regarding all our production and PART 2 which contains specific information regarding the motor-driven pump that you have purchased. The two booklets are complementary to each other, therefore make sure that you have both of them.

Follow the instructions given in these booklets in order to obtain optimum return and operation from your motor-driven pump. If any other information is necessary, please contact the nearest authorised retailer.

If the booklets contain contrasting information, keep to what is indicated in PART 2 (product specifications).

THE REPRODUCTION, EVEN PARTIAL, OF THE ILLUSTRATIONS AND/OR TEXT HEREIN IS FORBIDDEN.

The following symbols are used throughout the instruction booklets:

WARNING! Risk of damaging the pump or the system



Risk of injuring people or damaging things



Risks of an electrical nature

2. CONTENTS

1. INTRODUCTION	page 6
2. CONTENTS	page 6
3. MANUFACTURER IDENTIFICATION DATA	page 6
4. GUARANTEE AND TECHNICAL ASSISTANCE	page 6
5. GENERAL SAFETY WARNINGS	page 6
6. TECHNICAL-PRODUCTION CHARACTERISTICS	page 7
7. INSTALLATION, DISMANTLING AND TRANSPORTATION	page 7
8. ELECTRICAL CONNECTION	page 7
9. USE AND STARTING	page 8
10. MAINTENANCE AND REPAIRS	page 8
11. DISPOSAL	page 9
12. SUPPLIED TECHNICAL DOCUMENTATION	page 9
13. DECLARATION OF CONFORMITY	page 73

3. MANUFACTURER IDENTIFICATION DATA

**3.1. MANUFACTURER DATA
EBARA PUMPS EUROPE S.p.A.**

Plant management:
Via Pacinotti, 32 - 36040 BRENDOLA (VI) ITALY
Telephone: 0444/706811 - Telefax: 0444/706950 - Telex: 480536

Registered office:
Via Campo Sportivo, 30 - 38023 CLES (TN) ITALY
Telephone: 0463/660411 - Telefax: 0463/422782

3.2. MOTOR-DRIVEN PUMPS

See plates	6.1 for motor-driven surface pumps
in FIG. 6:	6.2 for submersible motor-driven pumps

For product type, see PART 2.

4. GUARANTEE AND TECHNICAL ASSISTANCE

THE GUARANTEE IS RENDERED NULL AND VOID IF THE INSTRUCTIONS GIVEN IN THIS BOOKLET ARE NOT ADHERED TO

AND/OR IF ANYONE OTHER THAN PERSONNEL FROM OUR HELP CENTRES INTERVENES ON THE MOTOR-DRIVEN PUMP. IN THESE CASES, THE MANUFACTURER IS RELIEVED FROM ALL RESPONSIBILITY REGARDING INJURY TO PEOPLE AND SUBSEQUENT DAMAGE TO ADJACENT ITEMS AND/OR THE MOTOR-DRIVEN PUMP ITSELF.

Once you have received the motor-driven pump, make sure that the packaging is not broken or seriously damaged. If it is, immediately inform the person who delivered it. After extracting the motor pump from its packaging, make sure that it was not damaged during transportation. If it has been, inform the retailer within 8 days from delivery. Check the motor-driven pump plate to ensure that the indicated characteristics are those requested by you.

The following parts, being normally subject to wear, have a limited guarantee:

- bearings
- mechanical seals
- grommets
- capacitors

If a fault that is not listed in the "TROUBLESHOOTING" table (chapter 10.1.) occurs, please contact the nearest authorised retailer.

5. GENERAL SAFETY WARNINGS

Before starting the motor-driven pump, the user must follow the operations indicated in this manual (PART 1 and PART 2), and apply them each time the motor-driven pump is used or when maintenance is carried out on it.

5.1. PREVENTIVE MEASURES TO BE TAKEN BY THE USER



Users must observe the accident prevention regulations that are in force in their countries at the time. They must also pay attention to the motor-driven pump characteristics (see "TECHNICAL DATA" in PART 2).



While repairing or carrying out maintenance on the motor-driven pump, disconnect the electric supply. Doing this avoids accidental starting, which could injure people and/or cause damage.

Any maintenance, installation or handling carried out on the motor-driven pump while it is still being powered can seriously injure, or even kill, people.

When starting the motor-driven pump, users must ensure that their feet are not bare or, worse, immersed in water. They must also ensure that their hands are not wet.

Users must not operate or carry out any work on the motor-driven pump that is not permitted in this manual.

5.2. IMPORTANT PROTECTIONS AND CAUTIONS



All motor-driven pumps are designed in such a way that all moving parts are made safe by using guards. The manufacturer declines any responsibility in the event of damages caused by the removal of said protections.



Each conductor or powered part is electrically insulated with regards to earth. Extra security is also added by connecting the accessible conducting parts to an earth conductor. This ensures that accessible parts cannot become dangerous should the main insulation become faulty.

5.3. RESIDUAL RISKS FOR SURFACE PUMPS

The only residual risk is the possibility of coming into contact (even if not accidentally) with the motor cooling fan by inserting thin objects (i.e. screwdrivers, small sticks, etc.) through the holes of the fan cover.

6. TECHNICAL-PRODUCTION CHARACTERISTICS

The motor-driven pump you have purchased has been designed and manufactured in compliance with the following directives:

- MECHANICAL RISKS (Enclosure I Machines Directive):
- EN 292-1 and EN 292-2
- ELECTRICAL RISKS (Enclosure I Machines Directive):
- EN 292-1 and EN 292-2
- CEI EN 60204-1
- VARIOUS RISKS (Enclosure I Machines Directive):
- 98/37/CE – Enclosure I

The electrical components and relative circuits installed on the motor-driven pumps are in accordance with the CEI EN 60204-1 Directive.

7. INSTALLATION, DISMANTLING AND TRANSPORT

WARNING!



INSTALLATION MUST BE CARRIED OUT BY A QUALIFIED ENGINEER.

7.1. GENERAL INSTALLATION PRECAUTIONS

- a) Use metal or rigid plastic pipes in order to avoid their yielding because of the depression created at suction;
- b) support and align pipes so that they do not put any stress on the pump;
- c) avoid throttlings caused by bending suction and delivery hoses;
- d) seal any piping connections: air infiltration in the suction pipe negatively affects pump operation;
- e) we recommend that a non-return valve and a gate are installed on the delivery pipe at the motor-driven pump outlet;
- f) fix the piping to the reservoir or to any fixed parts so that it is not supported by the pump;
- g) do not use a lot of bends (goosenecks) and valves;
- h) on SURFACE PUMPS installed above head, the suction pipe should be fitted with a foot valve and filter in order to prevent foreign matter from entering and its end should be immersed at a depth that is at least twice the diameter of the pipe; its distance from the bottom of the reservoir should also be one and a half times its diameter.
For suction longer than 4 metres use an oversized pipe (1/4" wider at suction for improved efficiency).

7.2. INSTALLATION

- a) Position the pump on a flat surface that is as close as possible to the water source. Leave enough space around the pump to allow safe use and maintenance. A free space of at least 100 mm must be kept in front of the cooling fan of surface pumps in all cases;
- b) lower submersible pumps using a rope fixed to the handle and hooks provided;
- c) use pipes of suitable diameters (see PART 2) fitted with threaded sleeves that must be screwed onto the pump suction and delivery unions or its threaded counterflanges;
- d) SURFACE PUMPS cannot be moved or used in the open except as stated in PART 2;
- e) for specific instructions, consult the chapter "PREPARING FOR USE" in PART 2.

7.3. DISMANTLING

The following must be done when moving or dismantling the motor pump:

- a) disconnect the electric supply;
- b) remove the delivery and suction pipes (where present) if too long or bulky;
- c) if present, unscrew the screws that secure the motor-driven pump to its supporting surface;
- d) if present, hold the power cable;
- e) lift the motor-driven pump using equipment suitable to the pump weight and dimensions (refer to the plate).

7.4. TRANSPORTATION

The motor-driven pump is packed in a carton or can be fixed to a wooden pallet, if pump weight and dimensions allow it. Transportation should not, in any case, present any particular problems.

Verify the total weight stamped on the box.

8. ELECTRICAL CONNECTION

- ELECTRICAL CONNECTION MUST BE CARRIED OUT BY A QUALIFIED ENGINEER.
- IT IS ADVISABLE TO INSTALL A HIGH INTENSITY DIFFERENTIAL SWITCH (0.03 A) ON BOTH THE THREEPHASE AND SINGLE PHASE VERSIONS.

WARNING!



We recommend that power is supplied to the motor-driven pump using an electric panel equipped with switch, fuses and a thermal switch calibrated to the current absorbed by the motor-driven pump.

The mains must be reliably earthed, according to the electrical regulations in force in the user's country; this is the installer's responsibility.

If the motor-driven pump is supplied without a power cable, use a cable that complies with the regulations in force and the necessary section according to length, power and mains voltage.

If present, the plug of the single phase version must be connected to the mains far from sprays, water jets or rain and it must be accessible.

The three phase version does not have an internal motor protector, therefore overload protection must be provided by the user.

MOTOR-DRIVEN SURFACE PUMPS

WHILE CONNECTING, MAKE SURE THAT BOTH THE TERMINAL BOARD AND THE MOTOR DO NOT GET WET.

- Connection of the single phase versions must be made on the basis of whether thermoamperometric protection "P" is internal (FIG. 1) or external (FIG. 2).
- For threephase versions, after connecting the star (FIG. 3) or triangle (FIG. 4) cable to the terminal board, looking at the pump from the motor side, check that the cooling fan turns in a clockwise direction. If this is not the case (and it turns in an anti-clockwise direction) invert two of three wires in the motor base.

SUBMERSIBLE MOTOR-DRIVEN PUMPS

- In single phase versions, plug the unit into the socket.
- For threephase versions (FIG. 5), check that the motor turns in a clockwise direction looking at the pump from the top, proceed as follows: with the motor-driven pump not yet secured to the system, connect the power cable to the terminal board and switch on briefly; the pump shall start with a kick in an anti-clockwise direction, seen from the top of the pump. If the direction is wrong (clockwise), invert two of the three wires in the terminal board of the electrical panel.

FIG. 7 shows the standard voltages shown on the plate with their respective tolerances.

8.1. ADJUSTMENTS AND RECORDINGS

In pumps fitted with a float, adjust the length of the float cable with regards to the minimum and maximum value of the water (see PART 2).

Check that the system automatisms do not require a number of start-ups higher than the number shown in FIG. 8 for surface pumps and in PART 2 for submersible pumps.

9. USE AND STARTING

NEVER ALLOW THE MOTOR-DRIVEN PUMP TO OPERATE WITHOUT WATER. DOING SO CAN SERIOUSLY DAMAGE THE INTERNAL COMPONENTS.

9.1. GENERAL WARNINGS

- a) Our surface pumps are designed to operate at a temperature no higher than 40°C and a level no higher than 1000 metres;
- b) our motor-driven pumps cannot be used in swimming pools or similar plants;
- c) prolonged motor pump operation with the delivery pipe closed can cause damage;
- d) avoid switching the motor pump on and off too frequently (check the maximum number in FIG. 8);
- e) during power cuts, it is advisable to disconnect the power to the pump.

9.2. STARTING

- a) Start the pump two or three times to check system conditions;
- b) restrict the delivery to cause a rapid pressure increase for a few times;
- c) make sure that the noise, vibration, pressure and electrical voltage levels are normal.

9.3. STOPPING

- a) Gradually interrupt water circulation in the delivery section to avoid overpressure in the piping and pump caused by water hammering;
- b) switch off the main switch.

10. MAINTENANCE AND REPAIRS

We recommend periodically checking that the pump is working correctly; pay particular attention to any abnormal noise or vibration and, for surface pumps, any mechanical seal leaks.

The main and most common special maintenance operations are generally as follows:

- replacement of mechanical seals
- replacement of grommets
- replacement of bearings
- replacement of capacitors.

When the SURFACE pump remains inactive for a long period, it should be emptied completely, removing the discharge and filling caps, washed carefully with clean water then emptied. Do not leave water deposits inside.

This operation must always be carried out whenever there is a chance of frost in order to avoid the breakdown of the pump components.

10.1. TROUBLESHOOTING

DISPLAYED FAULT	CAUSE	SOLUTION
THE PUMP DOES NOT WORK The motor does not turn	No electricity	Check the electrical supply meter
	Plug not inserted	Check the connection to the power supply
	Incorrect electrical connection	Check the terminal board and the electrical panel
	Automatic switch triggered or fuses blown	Reset the switch or replace the fuses and verify the cause
	Float sticking	Check that the float reaches the level ON
	Thermal protection activated (single phase)	It reactivates automatically (single phase only)

DISPLAYED FAULT	CAUSE	SOLUTION
THE PUMP DOES NOT WORK The motor turns	Decrease in the line voltage	Wait for voltage to return to normal
	Suction filter / hole blocked	Clean the filter / hole
	Foot valve blocked	Clean the valve and check its operation
	Pump not primed	Prime the pump Check any delivery non-return valves Check the liquid level
	Pressure too low	Restrict the delivery gate
	System undersized	Re-examine the system
THE PUMP WORKS with a reduced flow rate	System dirty	Clean the piping, valves, filters
	Water level too low	Switch off the pump or immerse the foot valve
	Incorrect rotational direction (threephase only)	Invert the two phases
	Incorrect supply voltage	Supply the pump with the voltage indicated on the ate
	Leaks from piping	Check the joints
	Pressure too high	Recheck the system
THE PUMP STOPS AFTER WORKING FOR BRIEF PERIODS Thermal protection intervention	Liquid temperature too high	The temperature exceeds the technical limits of the pump
	Internal fault	Contact the nearest retailer
THE PUMP STOPS AFTER WORKING FOR BRIEF PERIODS Pressure applications	The difference between maximum and minimum pressure is minimal	Increase the difference between the two pressures
THE PUMP DOES NOT STOP Pressure applications	Maximum pressure too high	Set maximum pressure at a lower value
	Flow rate too high	Reduce the flow rate
THE PUMP VIBRATES Or is too noisy during operation	Cavitation	Contact the nearest retailer
	Irregular piping	Fix in a better way
	Noisy bearing	Contact the nearest retailer
	Foreign bodies sliding along the motor fan	Remove the foreign bodies
	Incorrect priming	Bleed the pump and/or fill it again

11. DISPOSAL

When disposing of the pump, please comply rigorously with the regulations in force in your country, making sure that residues of the treated liquid are not left inside the pump. Most of our pumps do not contain hazardous polluting material. Specific cases are, however, indicated in the "DISPOSAL" chapter in PART 2.

12. SUPPLIED TECHNICAL DOCUMENTATION

12.1. DRAWING SHOWING THE ELECTRICAL CONNECTIONS OF A SINGLE PHASE MOTOR-DRIVEN PUMP

See FIG. 1-2

12.2. DRAWINGS SHOWING THE ELECTRICAL CONNECTIONS OF A THREEPHASE PUMP

See FIG. 3-4-5

12.3. EXAMPLE OF A PLATE

See FIG. 6.1-6.2 (The manufacturer reserves the right to modify it).

FIG. 1

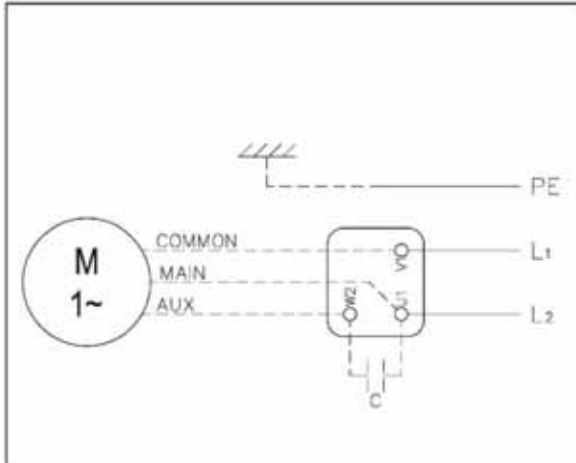

FIG. 2

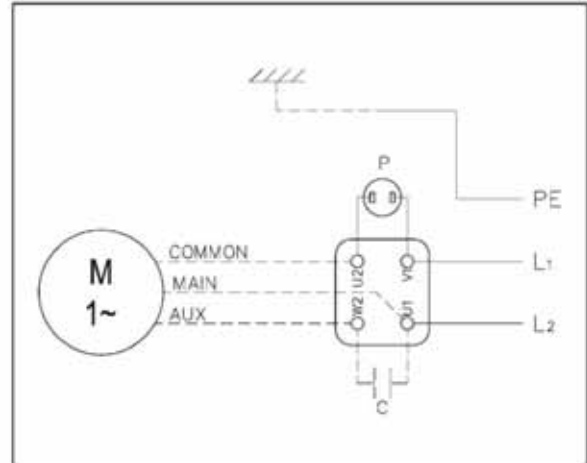

FIG. 3

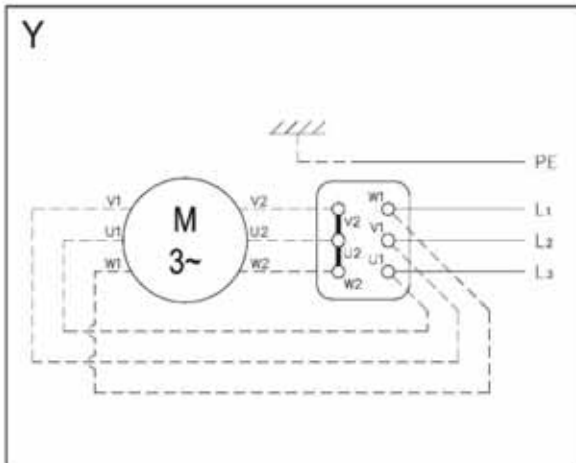

FIG. 4

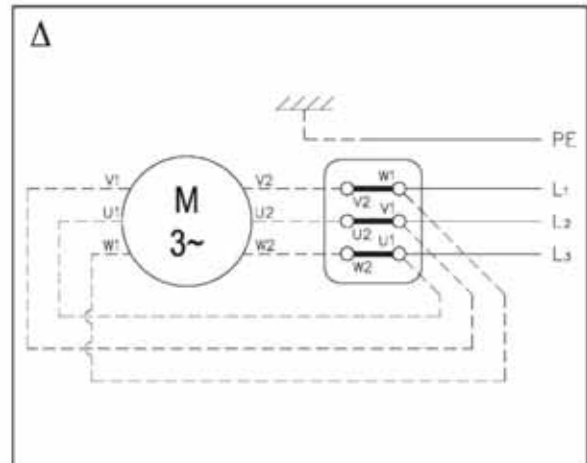
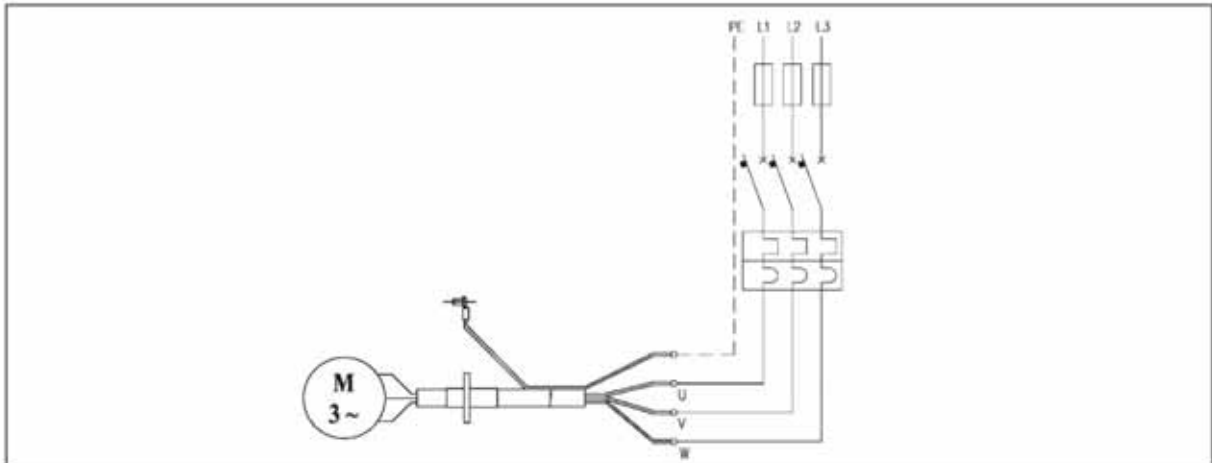

FIG. 5





OPERATING AND MAINTENANCE MANUAL PART 2
THE USER SHOULD KEEP THIS DOCUMENT

1. INTRODUCTION

This instruction manual is split into two booklets: PART 1, containing general information regarding our whole product range; and PART 2, containing information specific to the motor-driven pump you have purchased. The two publications are complementary to each other, so make sure you have both. Comply with the instructions contained in them to get the most out of your motor-driven pump and assure its proper operation. If you need further information, get in touch with your nearest authorized dealer. If information in the two parts contradict each other, take PART 2 containing the product's specific information as valid.

NO PART OF THESE ILLUSTRATIONS AND/OR TEXT MAY BE REPRODUCED FOR ANY REASON.

The following symbols have been used in the compilation of this instruction booklet:

WARNING	Risk of damaging the pump or system
	Risk of causing injury or damaging property
	Electrical hazard

2. CONTENTS

1. INTRODUCTION	page 4
2. CONTENTS	page 4
3. DESCRIPTION AND USE OF MOTOR-DRIVEN PUMP	page 4
4. SPECIFICATIONS	page 4
5. PREPARING FOR USE	page 5
6. DIAGRAMS AND DRAWINGS	page 36

3. DESCRIPTION AND USE OF MOTOR-DRIVEN PUMP

3.1. DESCRIPTION

Description	MOTOR-DRIVEN SURFACE PUMPS
MODEL / Type	3M-3LM-3BM Close-coupled steel pump
	3S-3LS-3BS Close-coupled with standard flanged motors and rigid coupling
	3P-3LP-3BP Coupled to motor with flexible coupling and supporting base
	3PF 3LPF-3BPF Free-shaft (with no motor and base)
	MD Close-coupled cast iron pump

The motor-driven pumps are employed to handle cold and hot water (see chap. 4) and are used in permanent installations. They are built with materials assuring long life and consistent performance if used according to the instructions given in Part 1 and 2 of the manual. Their special construction means they can be disassembled to service the motor and replace the impeller and mechanical seal without having to disconnect the pump casing from the suction and delivery lines. They are designed for medium and high delivery rates in conformity with EN 733 DIN 24255 standards and other corresponding European standards.

3.2. USE FOR WHICH PUMPS ARE DESIGNED

The motor-driven pumps can be used for the following applications:
RESIDENTIAL AND COMMERCIAL: water lifting, pressure boosting systems, air-conditioning, cooling.
FARMING: sprinkler or flood irrigation.
INDUSTRIAL: water handling, washing plants, transfer of moderately aggressive liquids compatible with AISI 304/316 steel for 3/3L-series models.
 Use the motor-driven pump based on its technical specifications.

3.3. USE FOR WHICH PUMPS ARE NOT DESIGNED

Series-3 and MD motor-driven pumps cannot be used to handle dirty water, water containing acids and corrosive liquids in general, water with temperatures higher than those mentioned in chap. 4, saltwater, flammable liquids and hazardous liquids in general. **The motor-driven pumps must never be made to work without liquid.**

4. SPECIFICATIONS

4.1. SERIES-3 PUMP SPECIFICATIONS

	U/M	3M-3LM-3BM	3S-3LS-3BS-3SF	3P-3LP-3BP 3PF-3LPF
Max. temperature of liquid pumped	°C	-10 +90 -10 +110 (3MH,3MHS,3LM)	-10 +90 -10 +110 (3S,3SHS,3LS)	-10 +90 -10 +110 (3PH,3PHS,3LP)
Suction diameter	mm	50-65-80		
Delivery diameter	mm	32-40-50-65		
Maximum working pressure	MPa	1		

4.2. MD PUMP SPECIFICATIONS

	U/M	MD
Max. temperature of liquid pumped	°C	90
Suction diameter	mm	50-65-80
Delivery diameter	mm	32-40-50-65
Maximum working pressure	MPa	1

4.3. SERIES-3, MD MOTOR SPECIFICATIONS

TYPE	TEFC
RATINGS	See motor-driven pump rating plate
OVERLOAD PROTECTION	SINGLE PHASE: thermal cutout w/ automatic reset THREE PHASE: by installer

4.4. INFORMATION ON AIRBORNE NOISE

Power kW	MOTOR		50 Hz		60 Hz	
	3_MMD Shaft height	3S-3P Shaft height	3_MMD LpA [dB] (A)*	3S-3P** LpA [dB] (A)*	3_MMD LpA [dB] (A)*	3S-3P** LpA [dB] (A)*
1.1	90	80	<70	<70	72	<70
1.5	90	90	<70	<70	72	70
2.2	90	90	<70	<70	72	70
3	100	100	71	<70	76	74
4	100	112	71	73	76	78
5.5	112	132	75	77	80	82
7.5	112	132	75	77	80	82
9.2	132	132	80	77	85	82
11	132	160	80	79	85	84
13	132	-	80 (MD)	-	-	-
15	132	160	80	79	85	84
15	160	160	83-82	79	88-87	84
18.5	160	160	83-82	79	88-87	84
22	160	180	83-82	80	88-87	85

Power kW	MOTOR		4 poles 50Hz	
	3_M Shaft height	3S-3P Shaft height	3_M LpA dB(A)*	3S-3P** LpA dB(A)*
≤ 3	71-100	71-100	<70	<70

* Sound pressure level - Mean value of measurements taken 1 m from the pump. Tolerance ± 2.5 dB.
 ** Sound pressure level of pumps featuring AEG motor.

THE MANUFACTURER RESERVES THE RIGHT TO AMEND TECHNICAL DATA FOR THE PURPOSE OF PRODUCT IMPROVEMENTS AND UPDATING.

5. PREPARING FOR USE

WARNING TO LIFT OR MOVE THE MOTOR-DRIVEN PUMP, USE A ROPE STRONG ENOUGH TO TAKE ITS WEIGHT, TAKING CARE NOT TO TILT THE PUMP TOO MUCH (MAX. 20°) (FIG. 1);

5.1. INSTALLATION SERIES 3, MD

To install the pumps, proceed as directed in PART 1, chapter 7.2 and in the following points:

- use pipes of a suitable diameter, bearing in mind that suction diameter (front side of pump) is different to delivery diameter (top side of pump), (see chap. 4).

5.1.1. FOR MOTOR-DRIVEN PUMPS 3P-3LP-3BP

Units from series 3P - 3LP - 3BP are mounted on a base. Since the units to be installed are not particularly heavy, and loads through the pipes are not expected to be heavy, a base plate is not essential. However, a raised base plate would make it easier to insert a container underneath to catch liquid when the pump casing needs draining, and would double as a safety platform when the floor is in danger of being flooded. When units are placed directly on the floor, all you need to do is set just the anchor bolts in the concrete.

Although the pump and motor have been aligned at the factory, the base plate may be distorted when the locking screws are fastened during installation. To assure correct alignment, use a comparator or callipers to make sure the distance between the two halves of the coupling is the same all the way round. Using a rule or comparator, also check alignment (concentricity) of the connector strip where the two halves of the coupling meet. The coupling's cover must be removed for alignment. Make sure you have refitted it before starting the pump. Checks must be made at four diametrically opposed points. Errors must be corrected by loosening or removing the screws if necessary to move the feet on the base and possibly add calibrated metal strips (FIG. 4).

IF ALIGNMENT IS NOT ACCURATE, YOU MAY ENCOUNTER VIBRATIONS, DAMAGE TO BEARINGS AND COUPLINGS AND THE END OF THE SHAFT MAY BREAK.

5.2. PIPEWORK SERIES 3, MD

To install pipes, proceed as directed in PART 1, chapter 7 and in the following points:

- a) do not fit the pump on misaligned pipes;
- b) use a suitable support for the suction and delivery line so as not to compromise the motor-driven pump's alignment;
- c) install a nonreturn valve between the pump and delivery gate valve in the following cases:
 - when piping is long;
 - when actual head is high;
 - when the pump is automatic;

DECLARATION OF CONFORMITY

We, EBARA PUMPS EUROPE S.p.A., declare under our own responsibility that our products conform to the Machinery Directive 98/37/EC, to the Low Voltage Directive 73/23/EEC, as amended by Directive 93/68/EEC and to the Electromagnetic Compatibility Directive 89/336/EEC as amended by Directive 93/68/EEC.

Mr. SASAKI KENICHI
President

- when water is pumped into the tank;
- when two or more pumps are working in parallel;
- d) suction system:
 1. the suction line should slope upwards (over 1/100) with respect to the pump to stop air pockets forming. Pipe couplings must be fastened so that air is not sucked in;
 2. the suction line must be as short and straight as possible;
 3. install the suction reducer as illustrated in FIG. 2 to stop air pockets forming.

5.3. FILLING MD PUMPS

WARNING OPERATION TO BE PERFORMED WITH THE MOTOR'S TERMINAL STRIP FULLY CLOSED.

- a) Unscrew the hexagonal cap located on the front of the pump casing at the top;
- b) with the aid of a funnel, fill the pump with water to overflowing;
- c) screw the hexagonal cap back on until it is locked tight to prevent air getting in.

5.4. DISASSEMBLING MOTOR-DRIVEN PUMPS (FIG.3)

The support of the 3M-MD-series pump is designed to allow maintenance work when needed, so that the motor assembly can be removed without disconnecting the casing from the pipes.

To remove the 3S - 3LS - 3BS motor-driven pump's motor, proceed as follows:

- with the aid of a screwdriver, remove the two mesh guards (44) by pressing towards the middle and pull them out of the slots in the sleeve (3) (fig. 3B);
- loosen the two screws (215) securing the coupling (6) on the end of the motor shaft - remove the screws (206) connecting the motor flange to the sleeve flange. For pumps coupled to motors according to construction method IM 335 (B3/B5 i.e. with flange and feet) (fig. C and D), remove the screws for fastening to the supports.

At this point, you can remove the motor from its housing, moving it axially. Parts are refitted following the procedure in reverse order.

Apply threadlocker to grub screws (215) to prevent loosening during operation.

5.5. DISASSEMBLING MOTOR-DRIVEN PUMPS 3P-3LP 3BP (FIG. 4)

All inside parts can be disassembled and inspected without removing the pump casing and pipes. Once you have isolated the motor-driven pump from the system (close the gate valves, disconnect all connections, drain the pump casing), disassemble in the order given below:

- coupling cover
- motor, and mount where applicable
- mount support
- mounting unit complete with impeller and seal holder disc
- parts are refitted following the procedure in reverse order.

DECLARATION OF INCORPORATION

1) We, EBARA PUMPS EUROPE S.p.A., declare under our own responsibility that our products "3PF" (supplied without motor) are in conformity with the Machinery Directive 89/392 as amended by the EEC Directive 91/368.
2) The above-mentioned products must not be put into service until the machinery into which it is to be incorporated have been declared in conformity with the provisions of EEC Directive 89/392.



COMMPAK PLUS – SYSTEM CONTROLLER - MODEL UP-TCM-01

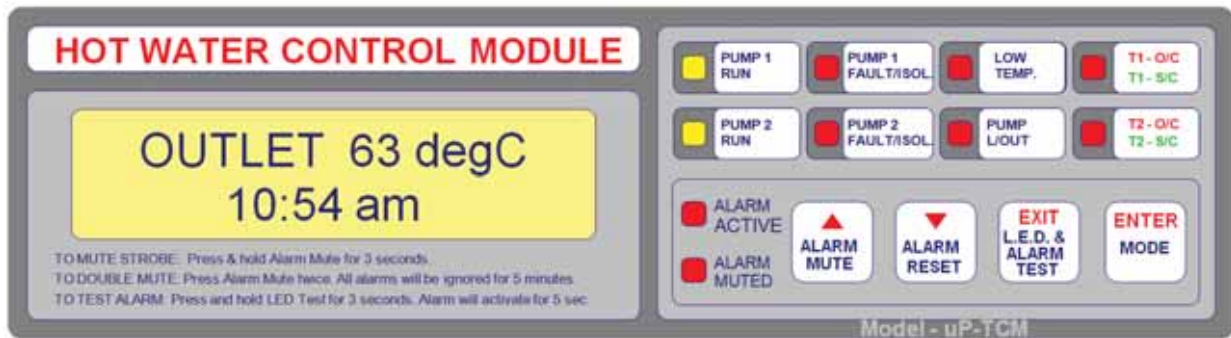

The uP-TCM-01 temperature control module is housed in a DIN rail mount enclosure with an equivalent width of 9 poles.

This microprocessor based module is designed for reliable temperature control and monitoring.

FACIA DISPLAY PANEL

- Four standard LEDs, six bi-coloured LEDs, one sixteen character two line liquid crystal display and four tactile push buttons are incorporated on the facia display panel, covered with a polyester label.

OUTPUTS

- Five output relays are included in the unit, to provide for control and alarm interface functions.
- Two relays are dedicated to pump control and the other three relays are for volts-free monitoring.
- The three volts free relays are user programmable for various alarm functions.
- One audible alarm output: 12VDC – 20mA (mutable) with user programmable maximum ON time facility
- One strobe light visual alarm output: 12VDC – 200mA (extinguishable).
- The module also incorporates a comprehensive alarm monitoring and annunciation facilities.

INPUTS

- Interface circuitry accommodates for three different types of temperature sensors.
- The module has provision for simultaneous monitoring of two temperature sensors.
- Being: T1 for the return water and T2 for the outlet water.
- Note: The temperature sensors are pre calibrated and do not require any additional adjustment.
- Eight digital inputs are also provided to enable / disable various controller functions.

OTHER FEATURES

- A set-up mode is incorporated to allow user access to numerous control parameters (if required) for fine tuning of the control module to best suit the required the application.
- Pump run hours and No. of starts are recorded for up to two pumps.
- A real time clock is provided to facilitate up to nine user programmable ON – OFF settings
- An alarm fault logger logs up to 40 faults, recording alarm type, time and date. Once 40 faults have been logged, then the oldest fault is over ridden by newest fault.
- All set-up parameters and recorded data are stored in non-volatile Eeprom.
- All cabling to the module is performed through plug in connectors. Commpak Plus – System Controller – Special Features

- Powered from 85 to 260VAC
- All connections to module are pluggable with all field wiring on one side of module.
- Two channel thermistor interface
- Configurable for three different thermistor types
- Comprehensive alarm monitoring
- Indicator and alarm test facilities
- Inbuilt hour run meters for up to two pumps
- Inbuilt pump start counters for up to two pumps
- Presets menu for viewing set parameters
- Set-Up mode for changing set parameters
- Temperature sensors are monitored for open-circuit and short circuit condition
- Push button beep verification
- All alarms can be muted, with any new alarm condition re-instating the alarm
- All alarms can be double muted to provide 5 minutes isolation of alarms (maintenance and testing)
- Two channel ultra violet unit monitor with selectable lock-out condition
- High temperature differential alarm with selectable lock-out condition
- Low temperature differential alarm with adjustable time delay
- Low temperature differential lock-out with adjustable time delay
- Individual pump start and stop settings for up to two pumps.
- Bicoloured LEDs to expand controller functionality
- 16 character, 2 line LCD with LED back lighting
- Real time clock
- Two relay outputs provided for pump control
- Three fully programmable volts-free relay outputs
- Inbuilt code switches to provide additional modes of operation
- Solvent resistant polyester film label
- Monitoring of up to 8 digital inputs
- Provision for external 12v audible alarm (if inbuilt Piezo is inadequate)
- Provision for external 12v strobe light
- Provision for low pressure monitoring (loss of Towns Mains)
- Provision for heater resetting.
- Comprehensive 40 fault data logger with time and date stamping (disabled in double mute mode)
- Selectable displayed Information during normal mode
- Selectable alarm output as continuous or timed (for situations where use of audible alarms is restricted)
- Selectable LCD backlight options
- Strobe output can be muted independently of alarm output
- Selectable P1 to P2 start delay and P1/P2 overlap time.

COMMPAK PLUS – SYSTEM CONTROLLER - OPERATION**TEMPERATURE SENSORS:**

- The module can cater for three different types of thermistors.
- Refer to the diagram for jumper settings.
- Sensor T1 is assigned to the Return Water. Sensor T2 is assigned to the Outlet Water. The default display shows Outlet temperature, if dual temperatures are selected then both the outlet and return temperatures are displayed.
- Each sensor is continually monitored, and if an open-circuit or a short-circuit condition is sensed, the audible alarm is activated.
- The alarm is indicated on the LCD and also on the respective sensor LED. red for o/c, and flashing green for s/c.
- This type of alarm is non-latching. Relay outputs are affected if set to sensor fault or common fault.
- If sensor T1 o/c or s/c fault occurs, its monitoring functions are automatically then read from the healthy T2 temperature sensor.
- Likewise, if sensor T2 o/c or s/c fault occurs, its monitoring functions are automatically then read from the healthy T1 temperature sensor. Should both sensors have o/c or s/c faults then all temperature monitoring will cease, and will replace the temperature reading on the LCD and automatic operation is disabled.

ULTRA VIOLET UNIT MONITORING:

- Up to two UV units can be monitored.
- The input circuitry can be configured for normally open or normally closed. Individual On and Off time delays are provided.
- The output can be set to follower or latched.
- UV fault annunciation is via a “UV1 Fault” & or a UV2 Fault” message being displayed on the LCD and activation of the general audible alarm.
- Relay outputs are affected if set to UV fault or common fault. If the UV lock-out is enabled, then the lock-out LED will activate and the pumps will turn off. The relay output pump lock-out is also affected.

LOW PRESSURE:

- An adjustable delay time of 1-99 seconds is provided.
- The output can set to follower or latched.
- The input circuitry is configured for normally open operation, closing on low water pressure.
- The Pump L/OUT LED will flash during the timing process (pending lock-out). On time out the Pump L/OUT LED will change from flashing to a steady ON condition, “Low Pressure L/Out” will be displayed on the LCD and the pump(s) will be locked-out.
- If set for ‘Follower’ operation the pumps will be automatically reinstated on the return of healthy water pressure
- If set for ‘Latched’ operation the pumps will not be reinstated until the RESET button is depressed.
- Relays:common fault, pump lock-out and low pressure (when activated) are also affected by this event.

HIGH TEMPERATURE MONITORING:

- The high temperature monitor can be set to either of the two temperature sensors T1 or T2.
- Individual ON and OFF temperature thresholds are provided. A time delay of 1-99 seconds is provided.
- The output can be configured as a follower or latched.
- The high temperature LED (if fitted) will flash during the timing process (pending alarm / lock-out).
- On time out “High Temp. Alarm or L/Out” will be displayed on the LCD.
- Relay outputs are affected if set to high temp, temp fault or common fault.
- If the high temperature lock-out is enabled, then “High Temp. L/Out” will be displayed and the pumps will turn off.
- The relay output pump lock-out is also affected.

LOW TEMPERATURE MONITORING:

- The low temperature monitor can be set to either of the two temperature sensors T1 or T2.
- Individual ON and OFF temperature thresholds are provided. A time delay of 1-99 minutes is provided.
- The output can be configured as a follower or latched.
- The low temperature LED will flash during the timing process (pending low temperature alarm).
- On time out the low temperature LED will change from flashing to a steady ON condition.
- Relay outputs are affected if set to low temp, temp fault or common fault.

LOW TEMPERATURE LOCK-OUT:

- The low temperature lock-out can be set to either of the two temperature sensors T1 or T2.
- Individual ON and OFF temperature thresholds are provided. A time delay of 1-99 minutes is provided.
- The output can be configured as a follower or latched.
- The pump lock-out LED will flash during the timing process (pending lock-out). On time out the Pump L/OUT LED will change from flashing to a steady ON condition.
- Relay outputs are affected if set to pump lock-out, temp fault or common fault.

PUMP FAULT MONITORING:

- Digital inputs are provided for to allow pump fault monitoring. These inputs operate virtually instantaneously when closed.
- They are utilised to provide LED indication of a pump fault and to lock-out of the pump. In a dual pump controller when one pump is in Fault, duty operation will be automatically transferred to the healthy pump.
- Pump fault is a follower condition and the faulty pump will automatically reinstate once the fault input is cleared

TEMPERATURE CONTROL:

- Pump control is primarily set in this section.
- The lead start/stop and lag start can be set to either T1 (return water temperature) or T2 (outlet water temperature).
- The lag stop is fixed to T1 (return water temperature).
- **On a single pump system, the on/off function is set by:**
 - ON = LEAD: START from **either** T1 **or** T2 sensors less than its set value
 - OFF = LEAD: STOP from T1 sensor being greater than its set value.

Note: To prevent short cycling of the the 1st up pump (lead pump) a minimum run timer is provided
- On activation the lead pump will run for minimum time as set in Page 3 CONTROL – LEAD MRT (1-99 minutes)
- **On a dual pump system, the LEAD pump on/off function is as per the above single pump system settings.**
- The LAG pump is set by: ON = LAG: START from **both** T1 **and** T2 sensors being less than their set values.
 - Plus start delay time as set in Page 3 CONTROL – LAG START DELAY (1-99 seconds)
 - OFF = LAG: STOP from T1 sensor being greater than its set value.

RELAY OUTPUTS:

- Three programmable relay outputs, RL1, RL2 and RL3 are provided for volts-free monitoring of the controller.
- These relays are **NORMALLY** set as an open output contact closing for their nominated function, but can be user selected within the program menu as **FAIL SAFE**, meaning a closed output contact opening for their nominated function.
- Each of the three relays can be set as to one of fifteen alarm types.
- Each relay is also provided with one dedicated option.
- Refer to the table below for available types.
- Note: If relay 5 is set to common fault, the output mode is automatically preset to failsafe.

Relay Output Options
P1 Run
P2 Run
Pu mp Run
P1 Ready
P2 Ready
Pu mp Ready
P1 Fault
P2 Fault
Pu mp Fault
Lo w temp
High Temp
Temp Fau lt
UV Fau lt
Sen sor Fault
Pu mp Lock-Out
Heater Reset (RL3 only)
Lo w Pressure Fault (RL4 only)
Common Fault (RL5 only)

CLOCK:

- If the clock is not selected (refer Page 5 DISPLAY – Temp/Time) then it can be viewed in Presets mode. In Set-Up mode the time, day and date can be adjusted.

PUMP CONTROL:

- The control page provides additional control functions.
- In the single pump controller, the relevant parameters are the MRT and clock control.
- The remaining functions pertain to pump alternation for dual pump systems.

- Pump run option determines if two pumps are permitted to run simultaneously (both pumps) or only as a duty and standby combination (one pump).
- The lead pump can be fixed as either Pump 1 or Pump 2, or set to alternate mode.
- Pump alternation can be either “Time” (adjustable from 1-99 hours):- Meaning the duty pump will be alternate every XX clock hours or “equalise” (adjustable from 1-99 hours):- Meaning the duty pump is alternated every XX hours based on actual pump run time.
- An additional menu item is “timed operation” when enabled pump operation will only occur at specific times of the day and or specific days of the week (refer System Controller – test sheet timed operation settings for additional information), when outside the set operating times ‘SLEEP MODE ON’ is displayed and the pumps are disabled. When in SLEEP MODE switch input No. 5 (when closed) can be utilised to provide a manual override and reinstate automatic pump operation.

HEATER RESET:

- If relay RL3 is set to heater reset, then the heater reset mode is enabled.
- This relay is then utilised for switching 240VAC to a slave contactor, with normally closed contacts wired in series with the power supply to the water heaters. If a low temperature condition (as set in PAGE 2 PARAMETERS / LOW TEMP / SET ON POINT) is active for a period of 4 minutes, then RL3 is activated for a period of 30 seconds, isolating the power to the water heaters.
- After the 30 seconds has elapsed, RL3 de-activates and power is restored to the Water Heaters causing them to reset and re-fire.
- This cycle will continue as long as the low temperature condition exists or until low temperature lock-out (if enabled)
- Refer: PAGE 2 PARAMETERS / LOW TEMP L-OUT/ INPUT DELAY times out.

LOW PRESSURE LOCK-OUT:

- The module has the provision to monitor Towns Mains pressure to the Hot Water System via a pressure switch.
- The pressure switch will be configured as contact closure on low pressure.
- If a contact closure is sensed continuously for a period as set in PAGE 2 PARAMETERS / LOW PRESSURE / ON DELAY (nominally 15 seconds), then the pumps will be locked out. “Low Pressure L/Out” will be displayed on the LCD, and the
- Pump Lock-Out LED will turn on. If the pumps require manual priming this fault will be set as a latched condition. To clear the fault **once the low pressure fault has been rectified and the pump has been reprimed** press the ‘Alarm Reset’ button.

ALARM RESET:

- Pressing alarm reset will reset all latched alarms. If COMMS are enabled, then it will also reset all latched alarms on all the connected modules.

LED TEST:

- Press and hold the LED and alarm test button and all LEDs will illuminate whilst the button is depressed.
- The bi-coloured LEDs will toggle between red and green in order to check both colours.

LCD BACKLIGHT:

- The LCD is provided with LED backlighting. The backlight operation can be set to manual or automatic, within the DISPLAY page of the menu system. In manual mode the backlight turns on whenever a button is pressed and remains on for X seconds as set in the backlight on time. Its range is 10 to 99 seconds. If set to 10 seconds then the backlight will remain on permanently. In the automatic mode the backlight turns on for any button or alarm operation. The time on function also applies to this mode after all alarms are cleared.

LCD CONTRAST:

- The LCD contrast is adjustable via a potentiometer, accessed by removing the module cover, refer to adjacent drawing for location.
- It is adjusted using a small straight bladed screwdriver. Clockwise to increase & Anti-clockwise to decrease.

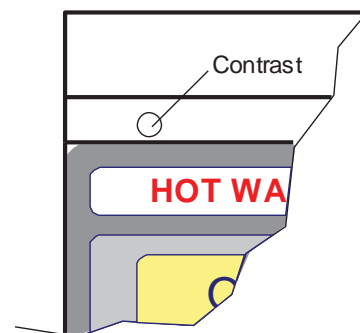
**ALARM SYSTEM:**

- The controller incorporates a comprehensive alarm monitor. Any given alarm condition can be muted by pressing the alarm mute button. If an alarm condition clears, but there is still one present, then the alarm will remain muted. If a new alarm condition is presented then the alarm will re-activate.
- All alarms will be logged unless the double mute mode is active.
- When the alarm is muted the audible alarms will be muted, but the strobe (if fitted) will remain active. To turn off the strobe, press and hold the alarm mute button for 5 seconds.
- If another fault appears the alarm and the strobe will re-activate.
- Relay Outputs are affected with various alarm conditions, refer to the detailed relay output options available.
- Alarm output mode is another option available within the DISPLAY page of the menu system. Options are continuous and timed.
- In continuous mode the alarm output remains active until muted or turned off, in timed mode the alarm only operates for X minutes then it automatically activates the alarm mute mode. If another alarm appears then the alarm will re-activate and start timing again.
- This mode is handy where audible and visual alarms cause problems with neighbouring residents.
- It is suggested that remote monitoring be utilised in conjunction with this mode.

ALARM TEST:

- Press and hold the LED and alarm Test button for 5 seconds and the LED Test function will turn off and the Alarm Test mode will be enabled. This function is self latching for 5 seconds, the alarm and strobe (if connected) will be activated.
- The alarm mute function can now also be tested by pressing the alarm mute button during this 5 second test period.

ALARM DOUBLE MUTE:

- If the alarm mute button is pressed twice within 1 second, double mute mode is enabled. The alarm muted LED will flash, and all alarms will be ignored for a 5 minute period. This mode is handy when commissioning installations where numerous alarms become annoying both locally and remotely on a monitored system.

Note: No faults are logged while this mode is active.

- This mode can be turned off by pressing alarm reset or by activating the alarm test function.

STROBE OUTPUT:

- A 12volt strobe output is provided. This will activate whenever the alarm activates. If the alarm is muted, the strobe will continue to operate. To mute the strobe, press and hold the alarm mute button for 5 seconds. Should a new alarm condition arise, the alarm and strobe will be re-activated.

DISPLAY OPTIONS:

- Within the DISPLAY page of the menu system, are display options for the LCD.
- This information will be displayed unless a fault message needs to be displayed.
- The display will rotate through all current fault messages at a 3 second refresh rate.
- There are four options as follows:
- Temp and time: Outlet temperature and time of day will be displayed.
- Pump stats: The display will circulate the P1 Hours, P2 Hours, P1 Starts and P2 Starts, with an update time of 3 seconds.
- Fault log: The display will show the status of the logger, i.e. Number of faults logged, and if >40 then Log O/Write.
- Dual temps: Outlet temperature and return temperature will be displayed.

FAULT LOG:

- Unless the controller is in the double mute mode, where all audible and visual alarms are muted for a 5 minute duration, or in
- Set-Up mode where alarm parameters can be altered, all alarm conditions are logged to memory. The logger will log the LAST 40 faults. Once the fault count exceeds 40, the logger starts overwriting itself. Each logged fault is time and date stamped.
- To view faults:
 - Enter the presets mode by pressing the MODE button. Press the DOWN button and "FAULT LOG will be displayed.
 - Press MODE again, and "VIEW FAULTS" will be displayed, along with "Last 40".
 - **Press MODE again and the number of faults logged will be displayed. Press MODE to display the last logged fault. Pressing the DOWN button will move down the fault list. Pressing the UP button will move up the fault list. The logged fault may include one or more faults if they occur simultaneously.**
 - **The information displayed on the LCD is Fault No., Fault description, and the time and date.**
- Pressing the EXIT button three times will exit this mode, or it will auto-exit after 60 seconds of button inactivity.

- The fault log can be cleared from within SET-UP mode.

INFORMATION:

- Within the INFORMATION page of the Menu System, is all the relevant information relating to this Controller.
- The following Information can be accessed: DiCon company contact details.
- Job Number, which should be provided if seeking additional info, or reporting a fault.
- Module Serial Number. Module Software Version.

PRESETS MODE:

- This mode is used to view all current settings, hour meters, start counters, general information and logged faults.
- To enter PRESETS MODE press the **MODE** button, '**CONTROLLER TYPE**' will be displayed (Refer to page 35 for Menu details)
 - Page 1 is CONTROLLER TYPE
 - Page 2 is PARAMETERS
 - Page 3 is CONTROL
 - Page 4 is PUMP STATUS
 - Page 5 is DISPLAY
 - Page 6 is INFORMATION
 - Page 7 is FAULT LOG
- By pressing the UP (▲) button you will step sequentially forward through the pages from page: 1 – 2 – 3 – 4 – 5 - 6 - 7.
- Pressing the DOWN (▼) button you will step sequentially backwards through the pages from page: 1 – 7 – 6 – 5 – 4 - 3 - 2.
- When you reached the relevant page to be viewed, press the **ENTER (MODE)** button.
 - This will display either the Sub Page Heading or the first item within the page.
 - Example: PAGE 2 - **PARAMETERS** is displayed, press the **ENTER** button and a sub page heading is now displayed.
 - Press the UP (▲) or DOWN (▼) button to step through to the required sub page, example: **TEMP. CONTROL**
 - Then press the **ENTER** button to display the first item within this page.
 - Then press the UP (▲) or DOWN (▼) button to step through to the required item within the sub page.
- Press **EXIT** to go back one level, or repeat pressing **EXIT** to quit the PRESETS DISPLAY mode altogether.

Notes: The controller will automatically exit this mode of operation once 60 seconds of button inactivity has expired.

- When in PRESETS DISPLAY mode, normal controller operation is unaffected.
- If a particular mode is disabled, then items relating to that mode will not be displayed.

SET-UP MODE:

This mode is utilised to enable user configuration of the controller to best suit any given application.

All data viewed within presets mode can be altered, except for the following:

Hour run meters, Start counters, job number, serial number, software version, firmware version and contact Details.

To enter **SET-UP** mode:

- Press and hold the **ALARM MUTE** (▲) and the **ALARM RESET** (▼) buttons simultaneously for 5 seconds.
- **'SET-UP MODE' 'press Enter'** will be displayed on the LCD. Press the **ENTER** button to proceed.
- Scrolling through the various pages, sub pages and items is identical to the Presets Mode above
- Refer page 38 of this manual for factory default settings and to record any changes made.
- When you have the data displayed that is to be changed, press the **ENTER** button.
- Brackets () will be inserted both sides of the selected data (this indicates that the selected data value can now be changed).
 - Press the UP (▲) or DOWN (▼) button to change the data to the required value.
 - Then press the **ENTER** button to SAVE the new data value and to clear the brackets ().
- Press the UP (▲) or DOWN (▼) buttons to move onto the next data value to be changed or Press the **EXIT** button to step back one level, or repeat pressing **EXIT** to quit SET-UP mode altogether.

Notes: If the data to be changed is a 2 digit number, you can press and hold down either the UP (▲) or DOWN (▼) button and after a short time the change rate will increase.

- If the data to be changed has more than 3 digits, then the data is changed 2 digits at a time.
- The active digits to be changed will flash, to scroll across to the next pair of digits to be changed press **EXIT**
- If an item in a SUB Menu is disabled, then the related following items may not be displayed.

COMPAK PLUS – SYSTEM CONTROLLER – PRESETS/SET-UP MODE SELECTION RANGES

PAGE	SUB-PAGE	ITEM	OPTIONS	MENU MODE		
				Presets	Set-Up	
1 - CONTROLLER TYPE		1-1 Hot water Controller	Single Pump Hot Water Controller	*	*	
2 - PARAMETERS	2.1 - UV SYSTEM	2.1.1 - UV Monitoring	Dual Pump Hot Water Controller	*	*	
		2.1.2 - Input State #	Disable, Enable	*	*	
		2.1.3 - On Delay #	N/Open, N/Closed	*	*	
		2.1.4 - Off Delay #	0-99 Seconds	*	*	
		2.1.5 - UV Lock-Out #	0-99 Seconds	*	*	
	2.2 - LOW PRESSURE	2.2.1 - On Delay	0-99 Seconds	*	*	
		2.2.2 - Output Mode	Disable, Enable	*	*	
	2.3 - HIGH TEMP.	2.3.1 - High Temp Alarm	Follower/Latched	*	*	
		2.3.2 - Sensor	Disable, Enable	*	*	
		2.3.3 - On Value #	T1,T2	*	*	
		2.3.4 - Off Value #	0-99 Deg. C	*	*	
		2.3.5 - Input Delay #	0-99 Deg. C	*	*	
		2.3.6 - Output Mode #	0-99 Seconds/Minutes	*	*	
		2.3.7 - Lock-Out #	Follower/Latched	*	*	
	2.4 - LOW TEMP.	2.4.1 - Low Temp Alarm	Disable, Enable	*	*	
		2.4.2 - Sensor	Disable, Enable	*	*	
		2.4.3 - On Value #	T1,T2	*	*	
		2.4.4 - Off Value #	0-99 Deg. C	*	*	
		2.4.5 - Input Delay #	0-10 Deg. C	*	*	
		2.4.6 - Output Mode #	0-99 Minutes	*	*	
	2.5 - LOW TEMP L/OUT	2.5.1 - Low Temp L/Out	Follower/Latched	*	*	
		2.5.2 - Sensor	Disable, Enable	*	*	
		2.5.3 - On Value #	T1,T2	*	*	
		2.5.4 - Off Value #	0-99 Deg. C	*	*	
		2.5.5 - Input Delay #	0-99 Deg. C	*	*	
		2.5.6 - Output Mode #	0-99 Minutes	*	*	
	2.6 - TEMP CONTROL	2.6.1 - Lead Sensor	Follower/Latched	*	*	
		2.6.2 - Lead Start Value	Disable, Enable	*	*	
		2.6.3 - Lead Stop Value	T1,T2	*	*	
		2.6.4 - Lag Sensor	0-99 Deg. C	*	*	
		2.6.5 - Lag Start Value	0-99 Deg. C	*	*	
		2.6.6 - Lag Stop Value	0-99 Deg. C	*	*	
	2.7 - RELAYS	2.7.1 - RL-3 Output	see Note 2 Below	*	*	
		2.7.2 - RL-3 Mode	Normal, Failsafe	*	*	
		2.7.3 - RL-4 Output	see Note 2 Below	*	*	
		2.7.4 - RL-4 Mode	Normal, Failsafe	*	*	
		2.7.5 - RL-5 Output	see Note 2 Below	*	*	
		2.7.6 - RL-5 Mode	Normal, Failsafe	*	*	
	2.8 - CLOCK	2.8.1 - Time	Normal, Failsafe	*	*	
		2.8.2 - Day	Set Time	*	*	
		2.8.3 - Date	Set Day	*	*	
	3 - CONTROL		3.1 - Pump Run	Set Date	*	*
			3.2 - Lead Pump	One Pump, Both Pumps	*	*
			3.3 - Pump Change	P1, P2, Alternate	*	*
			3.4 - Pump-Change Time	Equalise, Time	*	*
			3.5 - Lag Start Delay	1-99 Hours	*	*
			3.6 - Lead MRT	0-99 Seconds	*	*
3.7 - MRT Time #			Disable, Enable	*	*	
3.8 - Timed Operation			0-99 Minutes	*	*	
4 - PUMP STATUS		4.1 - P1 Hours Run	Disable, Enable	*	*	
		4.2 - P2 Hours Run	0-999999.99 Hours	*	*	
		4.3 - P1 Starts	0-999999.99 Hours	*	*	
		4.4 - P2 Starts	0-999999 Starts	*	*	
5 - DISPLAY		5.1 - Displayed Info	0-999999 Starts	*	*	
		5.2 - Back Light Mode	Time/Temp, Pump Stats, Fault Log, Dual Temps	*	*	
		5.3 - B/light on Time	Manual, Auto	*	*	
		5.4 - Alarm Mode	10(Always On)-99 Seconds	*	*	
		5.5 - Piezo Alarm	Continuous, Timed	*	*	
6 - INFORMATION		6.1 - DiCon Contact Details	Disable, Enable	*	*	
		6.2 - Code Entry	Toggles between 2 screens	*	*	
		6.3 - Job Number	0-9999	*	*	
		6.4 - Serial Number	25 Alpha Numeric Characters	*	*	
		6.5 - Software Version	0-9999	*	*	
7 - FAULT LOG		7.1 - Clear Log	8 Alpha Numeric Characters	*	*	
		7.2 - View Faults	No, Yes	*	*	
			Fault 40 - Fault 1	*	*	

Note 1: #-Not displayed if respective Mode disabled.

Note 2: Relay Output Options: P1 Run, P2 Run, Pump Run, P1 Ready, P2 Ready, P1 Fault, P2 Fault, Pump Fault, Low Temp, High Temp, Temp Fault, UV Fault, Sensor Fault, Pump Lock-Out, Heater Reset(RL3 Only), Low Pressure Fault (RL4 only) and Common Fault (RL5 only).

Note 3: To scroll down the menu, user must press up arrow key.

System Controller – Specifications

Power Supply:

100-250v AC, 50Hz
Module Load -xx mA max
 xx mA min

Display Indicators/Display:

4 x 3mm superbright LEDs.
6 x 3mm bi-Colour LED

Switches/Facia Push Buttons:

4 tactile pushbuttons provided for module operation

Control Inputs:

P1-Run, P1-Ready, P1-Fault (time delayed)
P2-Run, P2-Ready, P2-Fault (time delayed)
UV-1 monitor, UV-2 monitor
Referenced to module common
Pump manual run indication (Run LED flashes)

Analogue Inputs:

2 x Temperature Sensor inputs.
0-115 °C, with o/c & s/c detection.

Temperature Sensor Inputs:

Hardware selectable to:-
Type 1: VDO, Type 2-Rheem, Type 3-DiCon

Low Pressure Input:

Utilises one of the control inputs,
Fixed time delay Of 15 seconds.

UV Monitor Inputs:

Configurable inputs.
Adjustable ON delay 0-99 seconds.
Adjustable OFF delay 0-99 seconds.
Pump lock-out option.

High Temperature Alarm:

T1 or T2 selectable.
Separate ON and OFF set points.
Adjustable time delay 0-99 seconds.
Configurable as latching or self resetting.
Pump lock-out option.

Low Temperature Alarm:

T1 or T2 selectable.
Separate ON and OFF set points.
Adjustable time delay 0-99 minutes.
Configurable as latching or self resetting.

Low Temperature Pump Lock-Out:

T1 or T2 selectable.
Separate ON and OFF set points.
Adjustable time delay 0-99 minutes.
Configurable as latching or self Resetting.

Temperature Control:

Lead Pump: T1 or T2 selectable.
 Separate ON and OFF set points.
Lag Pump: T1 or T2 selectable.
 2 stage (Low &High) ON setpoints.
 Separate OFF (T1 only) point.

Volts Free Contacts:

Programmable as normal or fail-safe.
Programmable relays RL3, RL4 and RL5
Rated at 240v AC, 2 amp.

Contactor Relays:

Pump 1 and Pump 2 contactor/pump relays.
Rated at 240v AC 10 amp, 3 amp 0.7pf.

Hour Meters:

2 provided, P1 hours and P2 hours.
Resolution: 36sec (0.01 hour).
Range: 0.00-999999.99 hours.

Start Counters:

2 provided, P1 Starts and P2 Starts.
Range: 0-99999999 Starts.

Real Time CLock:

Time, day and date
With back-up approx 6 weeks back-up.

Pump Control Modes:

Selectable lead pump.
Auto lead pump change on pump time/clock.
Pump run selection – one/both.
Lead to lag start delay 0-99 seconds.
P1 to P2 Overlap delay.
Pump disable/enable clock settings.
Lead pump MRT.

Display Modes:

LED Test Mode
User selectable LCD display options: temp & time,
pump stats,
Fault log status and dual temps.

Alarm Output:

On Board Piezo provides audible alarm and
button/mode operation verification.
Alarm modes: continuous and timed (1-99 minutes)
Alarm mute and double mute modes.
Strobe output (muteable):
 Rating: 12 volt, 200mA max
Sonalert output (muteable):
 Rating: 12 volt, 20mA max

Display Backlight:

Manual and auto modes, with adjustable on-time
Range: 10-99 seconds.

Fault Logger:

Capacity: Last 40 Faults, all time and data stamped

Menu Modes:

Presets and set-up modes.

Communications:

On board RS485 communications are provided for
applications when this product is utilised with other
Dicon modularised products.

COMMPAK PLUS – SYSTEM CONTROLLER - FAULT/STATUS MESSAGES

- Initialising Eeprom:** Controller has rebooted, and loading all default settings into Eeprom.
- T1 Sensor Fault:** T1 (return water) sensor is faulty, refer to LED for o/c or s/c fault indication.
- T2 Sensor Fault:** T2 (return water) sensor is faulty, refer to LED for o/c or s/c fault indication.
- High Temp Fault:** High temperature fault alarm.
- High Temp. L/Out:** High temperature alarm is active and the pumps are locked-out.
- Low Press. L/Out:** Controller has detected a low pressure situation, restore water supply, reprime pumps
Press alarm reset to clear lock-out condition (if set to latched mode).
- UV-1 Fault:** UV-1 unit has failed, check operation/power supply, tubes etc.
- UV-2 Fault:** UV-2 unit has failed, check operation/power supply, tubes etc.
- Heater Resetting:** Low temperature input has been active for at least 4 minutes, so heaters are being reset.
- SET-UP Mode, press Enter:** Set-Up mode has been accessed, press ENTER to enter mode.
- Sleep Mode On:** Pumps are in standby mode and are disabled via the time clock, refer timed operation settings.
- Controller Locked-Out:** The controller has been locked-out, contact supplier for further instructions.

COMMPAK PLUS – SYSTEM CONTROLLER – MODULE BLOCK DIAGRAM

CONNECTION NOTES:

- All terminations on the module are pluggable.
- For ease of module replacement, each connector can be withdrawn, ensuring that cable connections are not transposed.
- Ensure the external alarm output current limits are not exceeded.
- The volts free contacts are rated at 240VAC 2 Amp, but be aware of its presence if using some for volts free monitoring.
- RS485 comms are ONLY for other DiCon control products, and cannot be used for any other purpose.
- Independent upstream protection is to be provided for each pump. The pump relays are configured as isolated contacts in order to provide this option.

Note:

- Pump Relays RL1 & RL2 are only suitable for loads less than: **240VAC 10 amp, 3 amp 0.7pf.**
- For loads exceeding these ratings a slave contactor of the appropriate rating is to be utilised.

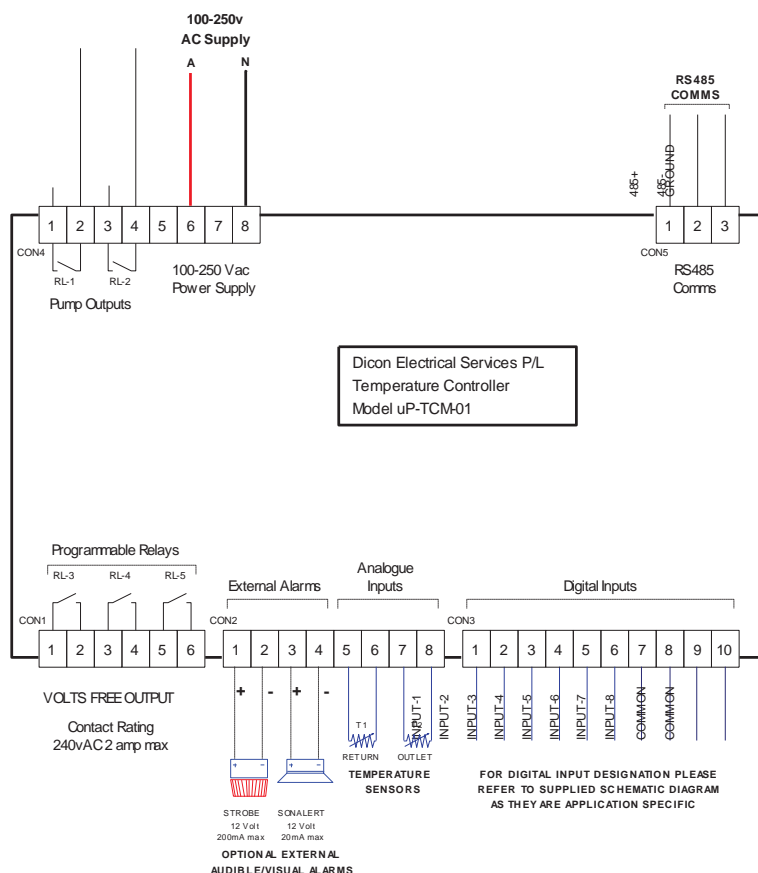

COMPAK PLUS – SYSTEM CONTROLLER – TEST SHEET

TEMPERATURE CONTROL MODULE uP-TCM TEST / INFORMATION SHEET -PAGE 1							
DICON JOB No.		CLIENT No.		A.C. SUPPLY REQUIREMENTS		VOLTS @ Hz	
MODULE SERIAL No.						AMPS(F.L.C.)	
PROJECT				SOFTWARE VERSION			
				HARDWARE VERSION		uP-TCM-01b	
NOTE: Most of the above information can be viewed within PAGE 6 - INFORMATION of the Menu System. Sensor T1 = Return Sensor T2 = Outlet							
CONTROLLER SET-UP MODE SETTINGS (To View - Presets Mode, To Edit - Setup Mode)							
PAGE 1 : CONTROLLER TYPE				PAGE 3: CONTROL			
Type	Options	Default	As Left		Options	Default	As Left
	1P HW Control, 2P HW Control	2P HW Control					
PAGE 2 : PARAMETERS				PAGE 4: PUMP STATUS			
U.V. SYSTEM	Options	Default	As Left	Pump Run	One, Both Pumps	Both Pumps	
UV Monitoring	Disabled, Enabled	Disabled		Lead Pump	Alternate, P1, P2	Alternate	
Input State	N/Open, N/Closed	N/Open		Pump Change	Equalise, Time	Equalise	
On Delay	0-99 seconds	60 seconds		Pump Change Time	1-99 Hours	3 hrs.	
Off Delay	0-99 seconds	90 seconds		Lag Start Delay	0-99 seconds	60 seconds	
UV Lock-out	Disabled, Enabled	Disabled		Lead MRT	Disabled, Enabled	Enabled	
LOW PRESSURE	Options	Default	As Left	MRT Time	0-99 minutes	3 minutes	
On Delay	0-99 seconds	15 seconds		Timed Operation	Disabled, Enabled, Default	Disabled	
Output Mode	Follower, Latched	Latched		If timed operation is enabled, refer settings on reverse of sheet.			
HIGH TEMP.				PAGE 5: DISPLAY			
High Temp Alarm	Disabled, Enabled	Enabled		Displayed Info	Temp/Time, Pump Stats, Logged Faults, Dual temps	Temp/Time	
Sensor	T1, T2	T2		P1 Hours Run	0-99999.99 hours	0 hours	
Set ON Point	0-99 deg. C	85 deg. C		P2 Hours Run	0-99999.99 hours	0 hours	
Set OFF Point	0-99 deg. C	80 deg. C		P1 Starts	0-999999	0 starts	
Input Delay	0-99 seconds	1 second		P2 Starts	0-999999	0 starts	
Output Mode	Follower, Latched	Follower		PAGE 7: FAULT LOG			
High Temp Lock-out	Disabled, Enabled	Disabled		Clear Log	No, Yes	No	
LOW TEMP.				JUMPER SETTINGS			
Low Temp Alarm	Disabled, Enabled	Enabled		<div style="display: flex; justify-content: space-around;"> <div style="text-align: center;"> <p>Comms</p> <p>EOL RESISTOR</p>  </div> <div style="text-align: center;"> <p>VDO</p>  </div> <div style="text-align: center;"> <p>Sensor Type</p> <p>RHEEM</p>  </div> <div style="text-align: center;"> <p>DICON</p>  </div> </div>			
Sensor	T1, T2	T2					
Set ON Point	0-99 deg. C	50 deg. C					
Set OFF Point	0-99 deg. C	52 deg. C					
Input Delay	0-99 minutes	10 minutes		ASSEMBLED BY: _____ DATE: / / TESTED BY: _____ DATE: / / PUMP SET WIRED BY: _____ DATE: / / PUMP SET TESTED BY: _____ DATE: / /			
Output Mode	Follower, Latched	Follower		COMMENTS:			
LOW TEMP. L/OUT				RL3, RL4 & RL5 Output Options P1 Run, P2 Run, Pump Run, P1 Ready, P2 Ready, Pump Ready P1 Fault, P2 Fault, Pump Fault, Low Temp, High Temp, Temp Fault, UV Fault, Sensor Fault, Pump L/Out, Heater Reset (RL3 only) Low Pressure (RL4 only), Common Fault (RL5 only)			
Low Temp L/Out	Disabled, Enabled	Enabled					
Sensor	T1, T2	T2		Notes:			
Set ON Point	0-99 deg. C	30 deg. C		All fault conditions are included in Common Fault			
Set OFF Point	0-99 deg. C	35 deg. C		Sensor T1 = Return, Sensor T2 = Outlet			
Input Delay	0-99 minutes	3 minutes					
Output Mode	Follower, Latched	Latched					
TEMP. CONTROL							
Lead Start - T1 OR	0-99 deg. C	40 deg. C					
Lead Start - T2	0-99 deg. C	55 deg. C					
Lead Stop - T1	0-99 deg. C	60 deg. C					
Lag Start-T1 AND	0-99 deg. C	40 deg. C					
Lag Start - T2	0-99 deg. C	55 deg. C					
Lag Stop - T1	0-99 deg. C	50 deg. C					
RELAYS							
Relay 3 Output	see below	Pump Fault					
Relay 3 Mode	Normal, Failsafe	Normal					
Relay 4 Output	see below	Temp Fault					
Relay 4 Mode	Normal, Failsafe	Normal					
Relay 5 Output	see below	Common Fault					
Relay 5 Mode	Normal, Failsafe	Failsafe					
CLOCK							
Time							
Day							
Date							

TEMPERATURE CONTROL MODULE uP-TCM TEST / INFORMATION - PAGE 2						
DICOM JOB No.		CLIENT No.		A.C. SUPPLY		
MODULE SERIAL No.				REQUIREMENTS		
PROJECT				VOLTS @ Hz		
				AMPS(F.L.C.)		
				SOFTWARE VERSION		
				HARDWARE VERSION uP-TCM-01b		
TIMED OPERATION SETTINGS (only applicable if function Enabled within Control Page)						
FUNCTION	Options	Default	As Left		FUTURE CHANGES - DATE:	
# Switched Input	Disabled, Enabled	Disabled				
FUNCTION	# TIME SETTINGS		# RANGE SETTINGS		TIME	DAY
	Default	As Left	Default	As Left		
OFF - 1	1:00 AM	am/pm	Off			
ON - 1	5:00 AM	am/pm	Off			
OFF - 2	1:00 AM	am/pm	Off			
ON - 2	5:00 AM	am/pm	Off			
OFF - 3	1:00 AM	am/pm	Off			
ON - 3	5:00 AM	am/pm	Off			
OFF - 4	1:00 AM	am/pm	Off			
ON - 4	5:00 AM	am/pm	Off			
OFF - 5	1:00 AM	am/pm	Off			
ON - 5	5:00 AM	am/pm	Off			
OFF - 6	1:00 AM	am/pm	Off			
ON - 6	5:00 AM	am/pm	Off			
OFF - 7	1:00 AM	am/pm	Off			
ON - 7	5:00 AM	am/pm	Off			
OFF - 8	1:00 AM	am/pm	Off			
ON - 8	5:00 AM	am/pm	Off			
OFF - 9	1:00 AM	am/pm	Off			
ON - 9	5:00 AM	am/pm	Off			

Timed Operation Function Description

Note 1 # Switched Input

When Enabled, Input No. 5 by-passes the timed operation & reverts to 24 hour temperature control. If the input is OPEN, Clock operation has control. If CLOSED the clock operation is bypassed. The manual bypass does not change any time/day setting within this page.

Note 2 # Time Settings : Nine (9) OFF & ON settable times available.

Note 3 # Range Settings : Each range setting can be assigned as:

- ANY : Reoccurs for everyday of the week.
- MON, TUE, WED, THUR, FRI, SAT, SUN : Occurs on a set day of the week.
- OFF : Indicates that the current OFF/ON setting is disabled.

TIMED OPERATION

Example: An office building is only manned between the hours of 8:00AM and 6:00PM Monday to Friday
This can be set as:

FUNCTION	TIME	RANGE
OFF-1	6:30 pm	Mon
ON - 1	7:30 am	Mon
OFF-2	6:30 pm	Tue
ON – 2	7:30 am	Tue
OFF-3	6:30 pm	Wed
ON – 3	7:30 am	Wed
OFF-4	6:30 pm	Thur
ON – 4	7:30 am	Thur
OFF-5	6:30 pm	Fri
ON - 5	7:30 am	Fri

OR

FUNCTION	TIME	RANGE
OFF-1	6:30 pm	Any
ON - 1	7:30 am	Any
OFF-2	7:30 am	Sat
ON – 2	**.** am	Off
OFF-3	7:30 am	Sun
ON - 3	**.** am	Off
OFF-4	**.** pm	Off
ON – 4	**.** am	Off
OFF-5	**.** pm	Off
ON - 5	**.** am	Off

Outside these set hours, the controllers display will show 'SLEEP MODE' to indicate the system is ready but disabled. When in 'SLEEP MODE' all temperature related alarm outputs are disabled (LED indication remains active).

Override: When in timed operation, Digital Input CON3 – 5 (refer connection notes Page 66) can be utilised to provide an override function.

Meaning: When a circuit is made between COMMON CON3 -9 or 10 and Input 5 the Hot Water System is re-enabled.

It is recommended that a Local OVERRIDE selector switch be provided to allow for hot water usage outside the normal pre-set operating hours, this feature is useful for cleaning staff, weekend work, functions, etc.

Note: This override function can also be used by Building Automation Systems, motion sensors etc. as the sole means of controlling ON & OFF operation.

Example: Set all 'Day' settings to OFF

System will only operate when Digital Input CON3 – 5 circuit is closed

Wiring: Digital Inputs are ELV – 12VDC optically coupled

Recommended Cable: 0.5mm² - 1 Pair screened cable

Please ensure, as with all instrument cabling that cables are run separate to power cables.

Maximum route length 30 metres.

For distances exceeding 30 metres it is recommended that an interposing relay be utilised.

Timed Operation can be enabled when in 'Set Up' Mode

Refer: System Controller Test Sheet - Page 3 Control.

When enabled 'Timed Operation Settings' as per the previous page are displayed.

The default setting for all 'Day' settings is 'OFF'

Up to nine (9) OFF & ON settings can be utilised, these times can be selected all in one day or spread across each day of the week.

Programming Instructions:

Once Enabled, press the **UP (▲)** button until

OF1 **:.**pm Off

On1 **:.**am Off is displayed

Press the **ENTER (MODE)** button, brackets will appear around the text; to indicate that these values can now be changed.

(OF1 **:.**pm Off)

(On1 **:.**am Off)

The text that can be changed will pulse

(OF1 **:.**pm Off)

(On1 **:.**am Off)

This value can be incremented UP or Down via the **UP (▲)** or **DOWN (▼)** buttons

Once the correct **TIME** setting is reached. Press the **EXIT (LED & Alarm TEST)** button to step to the next setting point

The text that can be changed will pulse

(OF1 **:.**pm Off)

(On1 **:.**am Off)

This value can be incremented UP or Down via the **UP (▲)** or **DOWN (▼)** buttons

Once the correct **RANGE** setting is reached. Press the **EXIT (LED & Alarm TEST)** button to step to the next point

The text that can be changed will pulse

(OF1 **:.**pm Off)

(On1 **:.**am Off)

Once all **OFF & ON TIMES** and **RANGES** have been set.

Press the **ENTER (MODE)** button to save changes & remove the (brackets)

Press the **UP (▲)** button to move onto the next **FUNCTION** OF2 **:.**pm Off

On2 **:.**pm Off is displayed

Repeat above steps until all **FUNCTIONS, TIMES & RANGES** have been set.

Press the **EXIT (LED & Alarm TEST)** button twice to return to NORMAL display mode.

COMPAK PLUS -PUMPS WIRING SCHEMATIC

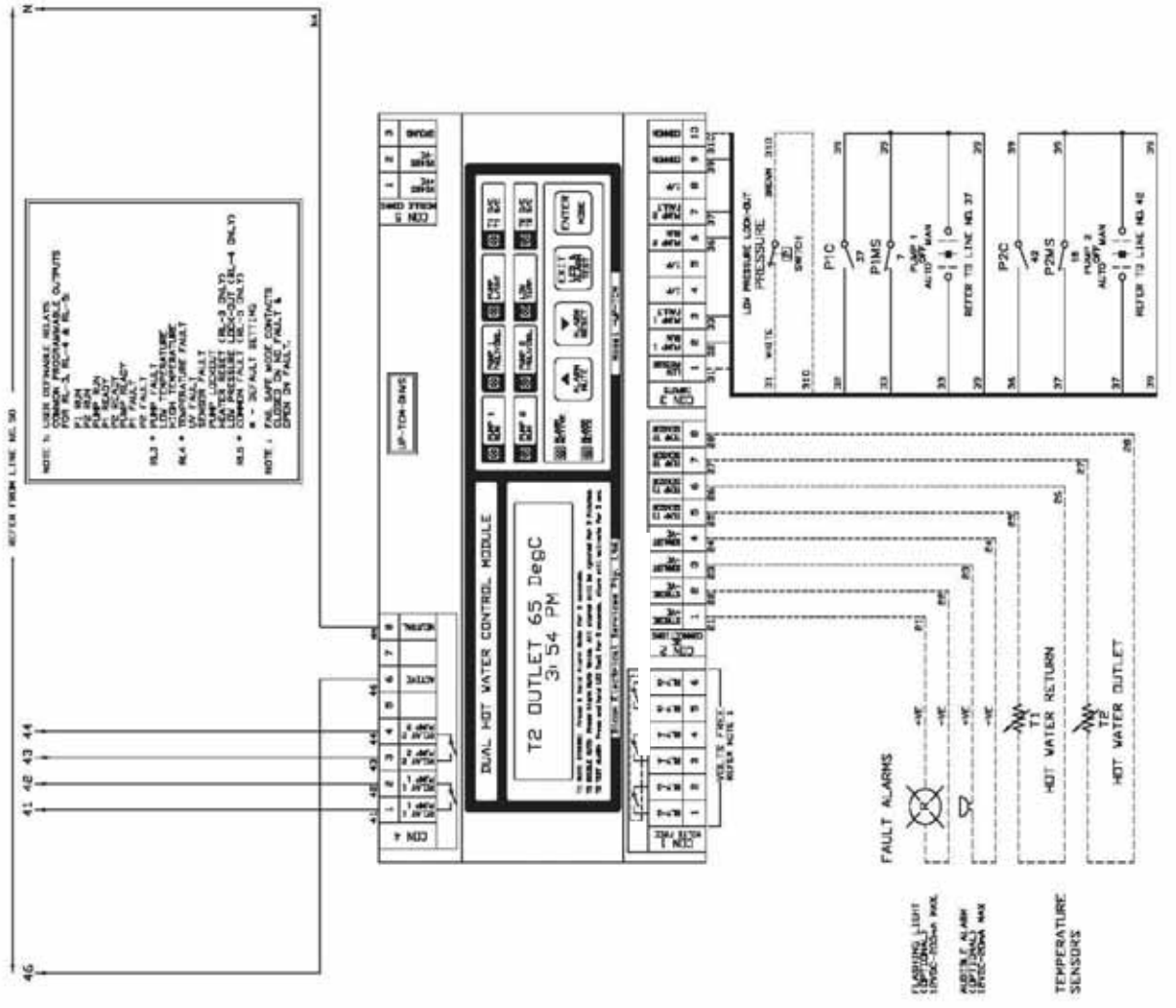
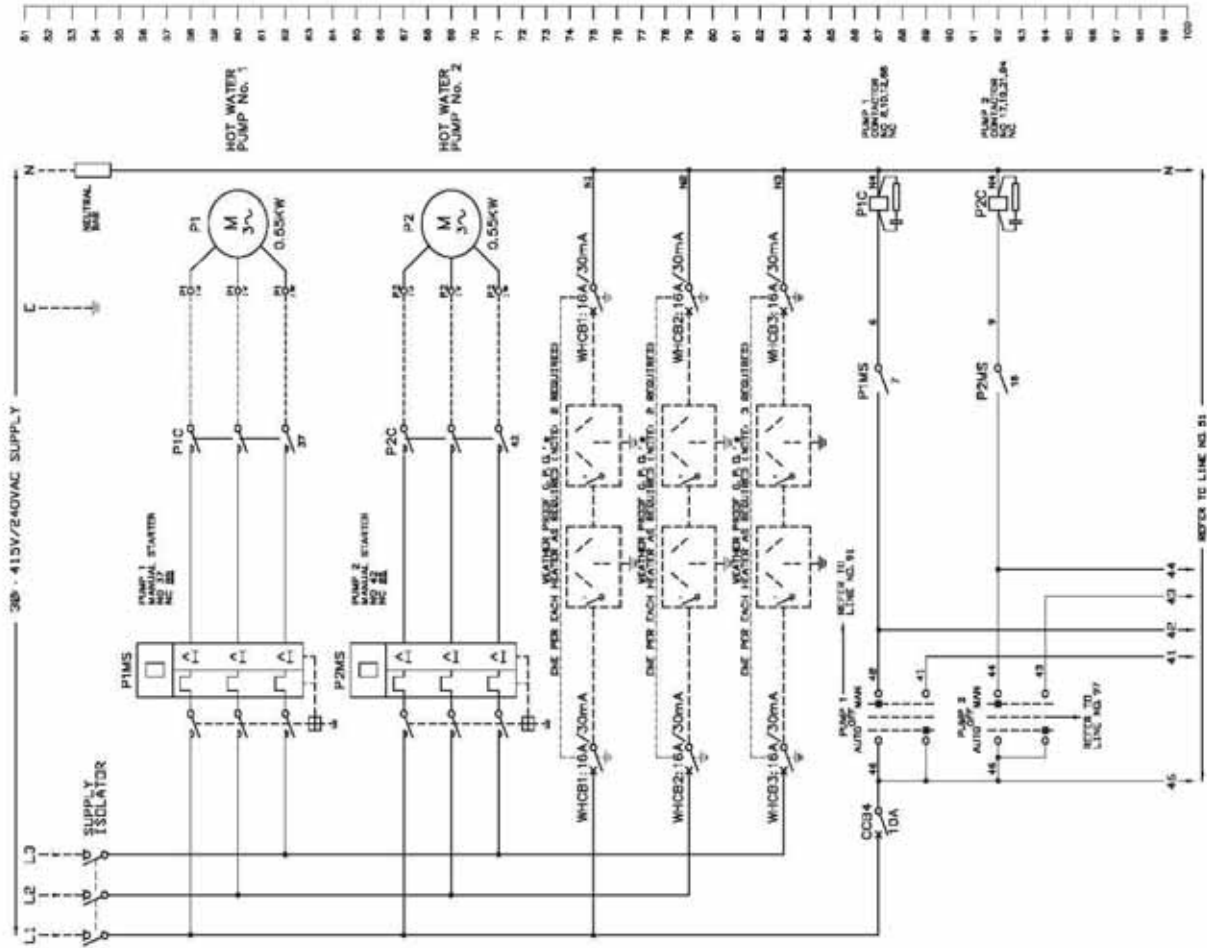

COMPAK PLUS – PUMPS LAY-OUT AND MATERIAL SCHEDULE

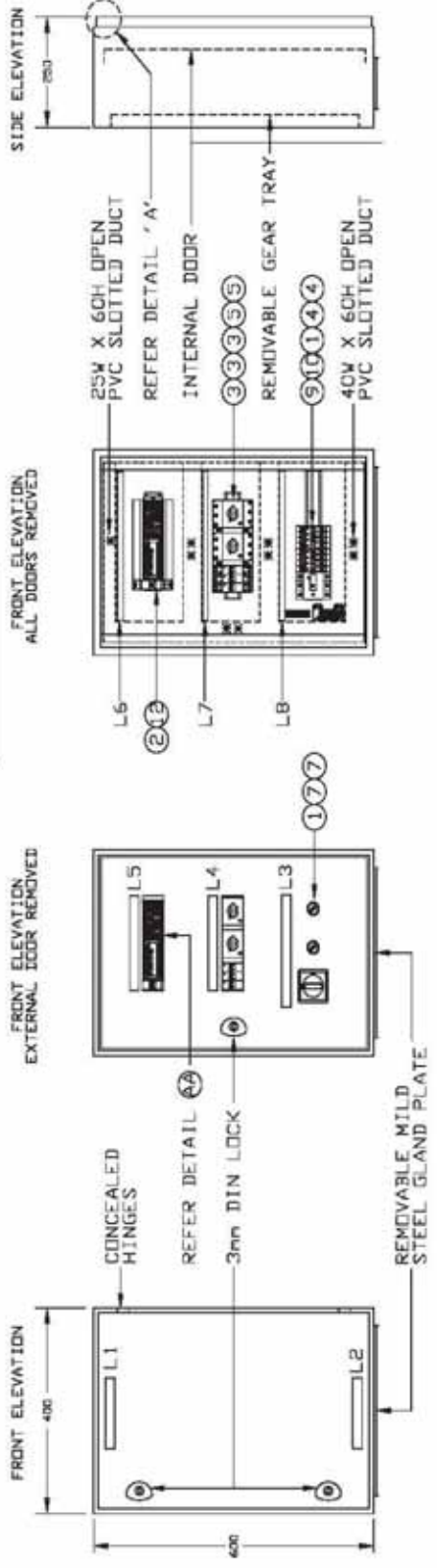

DETAIL 'A'

DOOR JAMB & DOOR DETAIL

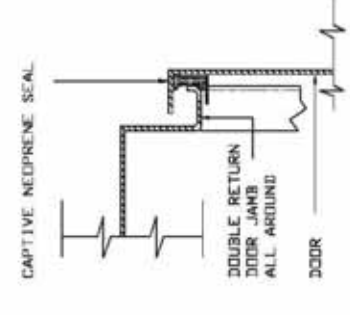

MATERIAL SCHEDULE

REFERENCE NO.	DESCRIPTION	SUPPLIER:	PART No.
1	SUPPLY ISOLATOR	ABB	UT63F 3S AC20-20KV/45A
2	CIRCUIT BREAKER 1 POLE	*	SD01-10A 6KA
3	RCD CIRCUIT BREAKER	*	DSN20IC16
4	CONTACTOR	*	A9-3D-1D 240VAC AC3-4KV/5A
5	MOTOR STARTER PROTECTION	*	MS30S-1.6 RANGE 1-1.6A
6	SELECTOR SWITCH	1BEC	ASV3P0 2P/2WD SERIES B1A
7	EARTH BAR	CLIPSAI	L5A LESS BASE 5 HOLE 50A
8	NEUTRAL BAR	*	L5A
9	CONTROL MODULE	DICON ELECTRICAL SERVICES P/L	MODEL No. UP-TCM-DHMS
10			
11			
12			
13			

LABEL SCHEDULE

L1	RHEEM AUSTRALIA PTY. LTD. MP2044		
L2			
L3	SUPPLY ISOLATOR	PUMP 1 AUTO. OFF MAN.	PUMP 2 AUTO. OFF MAN.
L4	MICB1 MICB2 MICB3 10A 10A 10A	P1MS P1MS	P2MS
L5	CC94 10A	DUAL HOT WATER PUMP CONTROLLER	
L6	CCB4 10A	UP-TCM-DHMS MODULE	
L7	MICB1 MICB2 MICB3 10A 10A 10A	P1MS	P2MS
L8	E/8	SUPPLY ISOLATOR	P1C P2C

DETAIL 'AA'

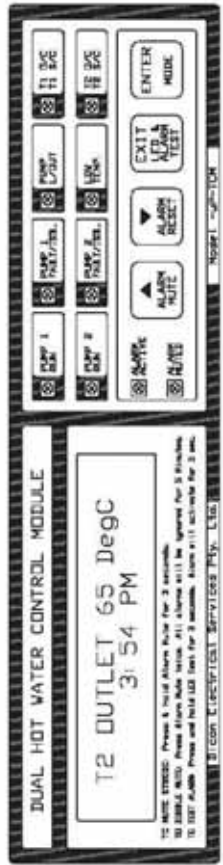

PANEL CONSTRUCTION

MATERIAL
 PANELS TO BE MANUFACTURED FROM
 MACHINE CALLED, FAST SEAM WELDER
 FROM WHICH WELD STEEL SHEET
 WITH THICKNESS 1.5mm

INTERNAL FINISHING TO BE MANUFACTURED
 FROM 8mm ZINC PLATED WELD STEEL SHEET.
 SUBSTITUTION FOR 1
 PROTECTION : JMS

FINISH
 EXTERNAL : POLYURETHANE
 COLOUR : GREY GAL. 7002

SUNDRIES

FRINGE : EXTERNAL : PLATED STEEL SCORERS
 INTERNAL : PLATED BRASS PINS

HINGES : CONCEALED HINGEABLE PIN TYPE

LOCKING : MOUNTED ON THE DOOR JAMB
 BLACK POLYURETHANE BLACK WITH
 WITH 2mm PIN, 90 Deg

SEALING

PLASTICIZING THE PANEL GASKET
 TO BE MANUFACTURED FROM THE
 ENTIRE PERIMETER OF THE DOOR

LABELS

MATERIAL : LAMINATE PLASTIC
COLOUR : BLACK LETTERING ON WHITE
 BACKGROUND

This page is intentionally blank

RHEEM CONTINUOUS FLOW GAS WATER HEATER WARRANTY – AUSTRALIA ONLY

CONTINUOUS FLOW GAS WATER HEATER COMPAK MODELS CP21 – CP36

1. THE RHEEM WARRANTY – GENERAL

- 1.1 This warranty is given by Rheem Australia Pty Limited ABN 21 098 823 511 of 1 Alan Street, Rydalmere New South Wales, the supplier of Rheem continuous flow gas water heaters, manufactured by Paloma Co., Ltd., a world leader in water heater technology and manufacture.
- 1.2 Rheem offer a trained and qualified national service network who will repair or replace components at the address of the water heater subject to the terms of the Rheem warranty. Rheem Service, in addition can provide preventative maintenance and advice on the operation of your water heater. The Rheem Service contact number is available 7 days a week on 131 031 with Service personnel available to take your call from 8am to 8pm daily (hours subject to change).
- 1.3 For details about this warranty, you can contact us on 131 031 or by email at warrantyenquiry@rheem.com.au (not for service bookings).
- 1.4 The terms of this warranty are set out in section 2 and apply to water heaters manufactured after 1st August 2014.
- 1.5 If a subsequent version of this warranty is published, the terms of that warranty will apply to water heaters manufactured after the date specified in the subsequent version.

2. TERMS OF THE RHEEM WARRANTY AND EXCLUSIONS TO IT

- 2.1 The decision of whether to repair or replace a faulty component is at Rheem's sole discretion.
- 2.2 Where a failed component or cylinder is replaced under this warranty, the balance of the original warranty period will remain effective. The replacement does not carry a new Rheem warranty.
- 2.3 Where the water heater is installed outside the boundaries of a metropolitan area as defined by Rheem or further than 25 km from either a regional Rheem branch office or an Accredited Rheem Service Agent's office, the cost of transport, insurance and travelling between the nearest branch office or Rheem Accredited Service Agent's office and the installed site shall be the owner's responsibility.
- 2.4 Where the water heater is installed in a position that does not allow safe or ready access, the cost of that access, including the cost of additional materials handling and/or safety equipment, shall be the owner's responsibility. In other words, the cost of dismantling or removing cupboards, doors or walls and the cost of any special equipment to bring the water heater to floor or ground level or to a serviceable position is not covered by this warranty.
- 2.5 This warranty only applies to the original and genuine Rheem water heater in its original installed location and any genuine Rheem replacement parts.
- 2.6 If the water heater is not sized to supply the hot water demand in accordance with the guidelines in Rheem's water heater literature, any resultant fault will not be covered by the Rheem warranty.
- 2.7 The Rheem warranty does not cover faults that are a result of:
 - a) Accidental damage to the water heater or any component (for example: (i) Acts of God such as floods, storms, fires, lightning strikes and the like; and (ii) third party acts or omissions).
 - b) Misuse or abnormal use of the water heater.
 - c) Installation not in accordance with the Owner's Guide and Installation Instructions or with relevant statutory and local requirements in the State or Territory in which the water heater is installed.
 - d) Connection at any time to a water supply that does not comply with the water supply guidelines as outlined in the Owner's Guide and Installation Instructions.
 - e) Repairs, attempts to repair or modifications to the water heater by a person other than Rheem Service or a Rheem Accredited Service Agent.
 - f) Faulty plumbing or faulty gas or power supply.
 - g) Failure to maintain the water heater in accordance with the Owner's Guide and Installation Instructions.
 - h) Transport damage.
 - i) Fair wear and tear from adverse conditions (for example, corrosion).
 - j) Cosmetic defects.
 - k) Ice formation in the waterways of a water heater: where the electricity supply has been switched off or has failed and the water heater has not been drained in accordance with the instructions; or due to an ambient temperature below -20°C (including wind chill factor).
- 2.8 If you require a call out and we find that the fault is not covered by the Rheem warranty, you are responsible for our standard call out charge. If you wish to have the relevant component repaired or replaced by Rheem, that service will be at your cost.
- 2.9 Subject to any statutory provisions to the contrary, this warranty excludes any and all claims for damage to furniture, carpet, walls, foundations or any other consequential loss either directly or indirectly due to leakage from the water heater, or due to leakage from fittings and/ or pipe work of metal, plastic or other materials caused by water temperature, workmanship or other modes of failure.

RHEEM CONTINUOUS FLOW GAS WATER HEATER WARRANTY – AUSTRALIA ONLY

CONTINUOUS FLOW GAS WATER HEATER COMMPAK MODELS CP21 – CP36

3. WHAT IS COVERED BY THE RHEEM WARRANTY FOR THE WATER HEATERS DETAILED IN THIS DOCUMENT

3.1 Rheem will repair or replace a faulty component of your water heater if it fails to operate in accordance with its specifications as follows:

What components are covered	The period in which the fault must appear in order to be covered	What coverage you receive
All components	Year 1	Repair and/or replacement of the faulty component, free of charge, including labour.
All components (only if the water heater is installed in a single-family domestic dwelling)	Years 2 & 3	Repair and/or replacement of the faulty component, free of charge, including labour.
The heat exchanger (if the water heater is installed in a single-family domestic dwelling)	Years 4 to 10	Replacement heat exchanger, free of charge. Installation and repair labour costs are the responsibility of the owner.
The heat exchanger (if the water heater is <u>not</u> installed in a single-family domestic dwelling)	Years 2 to 5	Replacement heat exchanger, free of charge. Installation and repair labour costs are the responsibility of the owner.
The heat exchanger (with a thermostat setting greater than 75°C)	Year 1	Repair and/or replacement of the faulty component, free of charge, including labour.

4. ENTITLEMENT TO MAKE A CLAIM UNDER THIS WARRANTY

- 4.1 To be entitled to make a claim under this warranty you need to:
- Be the owner of the water heater or have consent of the owner to act on their behalf.
 - Contact Rheem Service without undue delay after detection of the defect and, in any event, within the applicable warranty period.
- 4.2 You are **not** entitled to make a claim under this warranty if your water heater:
- Does not have its original serial numbers or rating labels.
 - Is not installed in Australia.

5. HOW TO MAKE A CLAIM UNDER THIS WARRANTY

- 5.1 If you wish to make a claim under this warranty, you need to:
- Contact Rheem on 131031 and provide owner's details, address of the water heater, a contact number and date of installation of the water heater or if that's unavailable, the date of manufacture and serial number (from the rating label on the water heater).
 - Rheem will arrange for the water heater to be tested and assessed on-site.
 - If Rheem determines that you have a valid warranty claim, Rheem will repair or replace the water heater in accordance with this warranty.
- 5.2 Any expenses incurred in the making of a claim under this warranty will be borne by you.

6. THE AUSTRALIAN CONSUMER LAW

- 6.1 Our goods come with guarantees that cannot be excluded under the *Australian Consumer Law*. You are entitled to a replacement or refund for a major failure and for compensation for any other reasonably foreseeable loss or damage. You are also entitled to have the goods repaired or replaced if the goods fail to be of acceptable quality and the failure does not amount to a major failure.
- 6.2 The Rheem warranty (set out above) is in addition to any rights and remedies that you may have under the *Australian Consumer Law*.

RHEEM AUSTRALIA PTY LTD
A.B.N. 21 098 823 511
www.rheem.com.au

FOR SERVICE TELEPHONE
131 031 AUSTRALIA
0800 657 335 NEW ZEALAND