

INSTALLATION INSTRUCTIONS



ECOSPOT SELECT SINGLE 10W LED SPOTLIGHT LHT1058 BLACK / LHT1059 WHITE

ECOSPOT SELECT TWIN 10W LED SPOTLIGHT LHT1056 BLACK / LHT1057 WHITE

Thank you for purchasing the Simx Lighting EcoSpot Select LED spotlight. This product is suitable for sheltered exterior locations. It requires a 230V AC power supply to operate and should be installed by a registered electrician. Please read this manual before installation and retain for future reference.

TECHNICAL SPECIFICATIONS

Power Source	220-240V AC
IP Rating	IP54
Safety	Class II
Mounting	Ceiling or wall
Construction	UV-stabilised polycarbonate
Warranty	3 years

LHT1058/LHT1059 Single Spotlight

Rated Load	10W
Lumens	3000K 900 lumens
by Colour Temp	4000K 1000 lumens
	5000K 950 lumens

LHT1056/LHT1057 Twin Spotlight

Rated Load	20W
Lumens	3000K 1800 lumens
by Colour Temp	4000K 2000 lumens
	5000K 1900 lumens



! IMPORTANT

This product is suitable for use only with a supply voltage of 220-240V AC 50Hz. All electrical work must be carried out in accordance with local and national electrical codes as applicable. We strongly recommend that this light fitting is installed by a registered electrician.

Always switch power off prior to installation. A means of mains power isolation must be installed in the circuit for the purpose of safe access for any internal cleaning, recalibration, or maintenance.

This light fitting is not intended for use by persons (including children) with reduced physical, sensory or mental capabilities, or lack of experience and knowledge, unless they have been given supervision or instruction concerning use of the appliance by a person responsible for their safety. Young children should be supervised to ensure that they do not play with the appliance.

Any changes or modifications made or attempted to this product, without the prior written approval of the manufacturer, will void any and all stated warranties.

BEFORE YOU START

Please read all the instructions prior to installation.

The EcoSpot Select should be wired to its own light switch. Do not interconnect with other lamp types on the same switch. An earth connection must be used for electrical safety.

To achieve best results, please consider the following points:

- EcoSpot Select should be mounted 1.8 to 3.0 metres above the ground.
- This light fitting is rated to IP54 making it suitable for sheltered exterior locations, please ensure the desired location does not exceed this rating.

INSTALLATION

We strongly recommend this light fitting is installed by a registered electrician

- Switch off the power supply before commencing any electrical work.
- Unscrew the fixing cover screws and remove the rear cover.
- Use the rear cover to mark the position of screw holes onto mounting surface.
- Drill the wall to depth of about 4 cm and fit the wall plugs (supplied).
- Care should be taken to avoid drilling or screwing into concealed electrical wiring/plumbing.
- Push the cable through the cable gland. Affix the back of the housing to the mounting surface with mounting wall screws.
- Connect the power cables to the terminal block securely (refer to Fig. 1). Refit the terminal block and cable anchorage. Select lamp colour from internal dip switch (refer to Fig. 2).
- Reattach and screw securely the cover to the base. Ensure cables are not pinched in closing the unit.
- Reconnect mains power.
- Test circuit (see below).
- Before any aiming adjustments, switch EcoSpot Select off and allow the hot lamp housings to cool.

Fig. 1

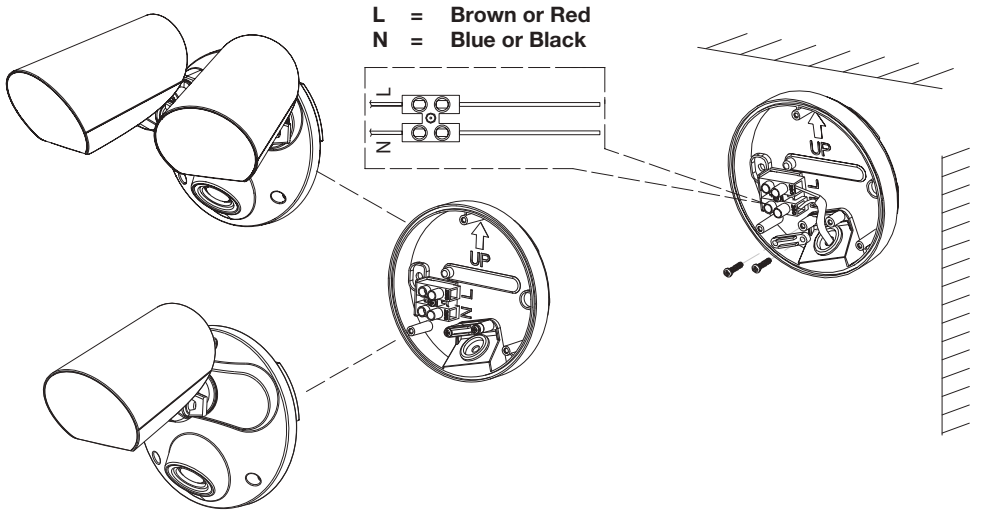
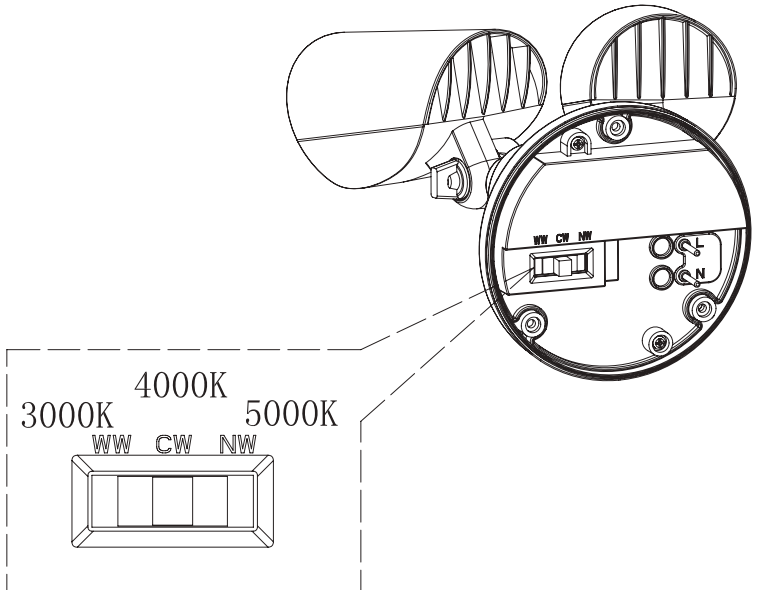

Fig. 2



Selecting lamp colour with power supply connected may cause irreparable damage. Always disconnect at mains before making any colour selection.

PRODUCT COMPLIANCES

Product complies with:

This product conforms to relevant AZ/NZS standards.

MANUFACTURERS EXTENDED WARRANTY

This product is guaranteed by SIMX Ltd and Ventair Pty Ltd for 3 years from the date of purchase against faulty materials or workmanship which affects its designed ability to operate. During this period if the product has a defect of this nature it will be repaired or replaced free of charge by SIMX with the same item, or a similar one of higher specification.

ON CONDITION THAT:

- The buyer returns it to the seller from whom it was bought, freight paid.
- The product has been bought by the user (ie. a receipt/sales invoice is produced as proof of purchase).
- The product has not been misused or handled carelessly, installed in any way contrary to the installation instructions, or installed in any unusually exposed or harsh environmental conditions.

This guarantee excludes liability for discolouration and/or delamination of paint or plastic, or any user serviceable parts. It does not confer any rights other than those expressly set out above and does not cover any claims for consequential loss or damage.

Our Goods come with guarantees that cannot be excluded under either Australian, or New Zealand, Consumer Law.

You are entitled to a replacement or refund for a major failure and for compensation for any other reasonably foreseeable loss or damage. You are also entitled to have the Goods repaired or replaced if the Goods fail to be of acceptable quality and the failure does not amount to a major failure.



Distributed in New Zealand by Simx Ltd

Ph: +64 9 259 1660 | Technical Support Ph: +64 9 259 1662

e: sales@simx.co.nz | www.simx.co.nz

Distributed in Australia by Ventair Pty Ltd

4 Capital Place, Carrum Downs, 3201 VIC, AUSTRALIA.

Technical Support: 1300 665 926

e: info@ventair.com.au | www.ventair.com.au