

* Dimensions to be in accordance with NZBC Clause E2

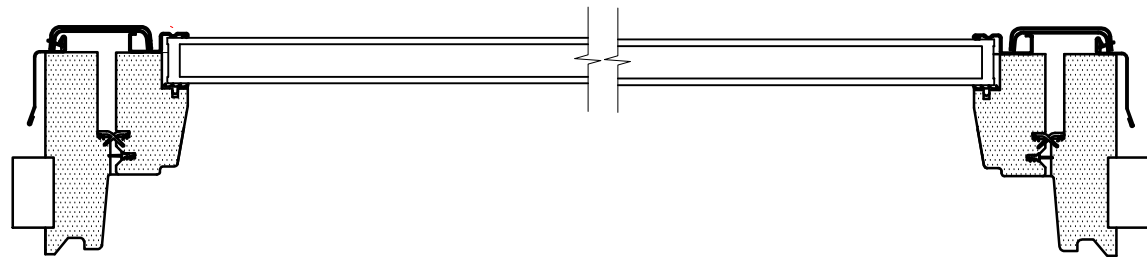

Keylite Centre Pivot - Trim Size					
Model No.	Keylite Overall		Trim Size		
	wide	high	wide	high	
CP-01	550	x 780	590	x 820	
CP-02	550	x 980	590	x 1020	
CP-04	780	x 980	820	x 1020	
CP-05	780	x 1180	820	x 1220	
CP-06	780	x 1400	820	x 1440	
CP-08	1140	x 1180	1180	x 1220	
CP-08F	1140	x 1400	1180	x 1440	

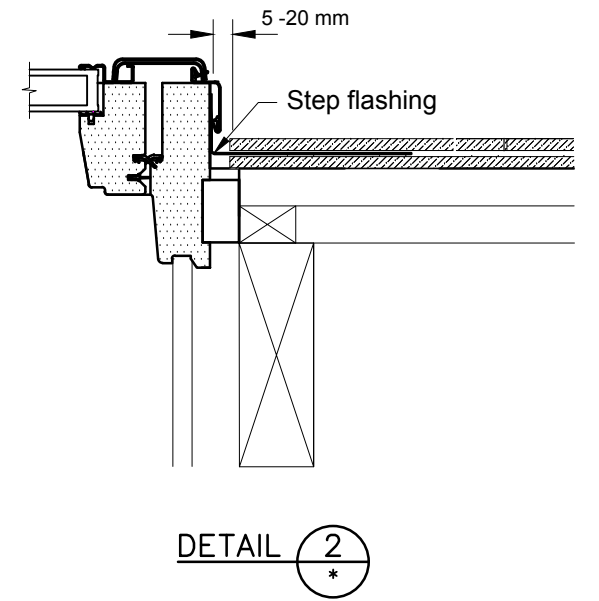
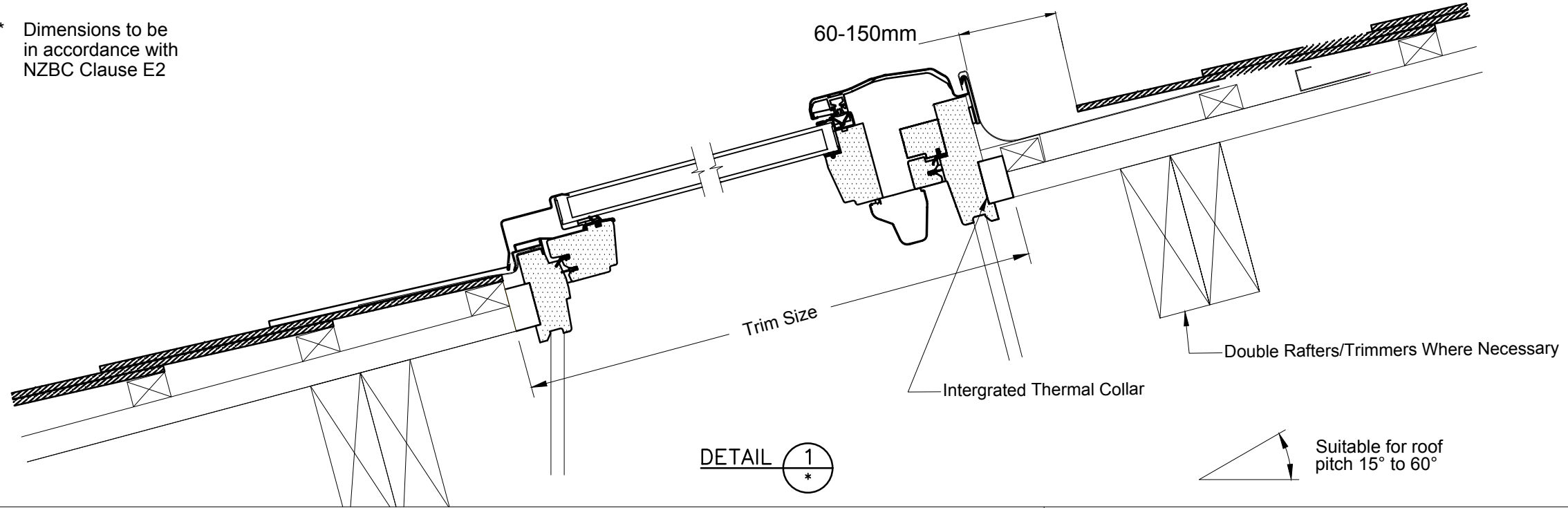
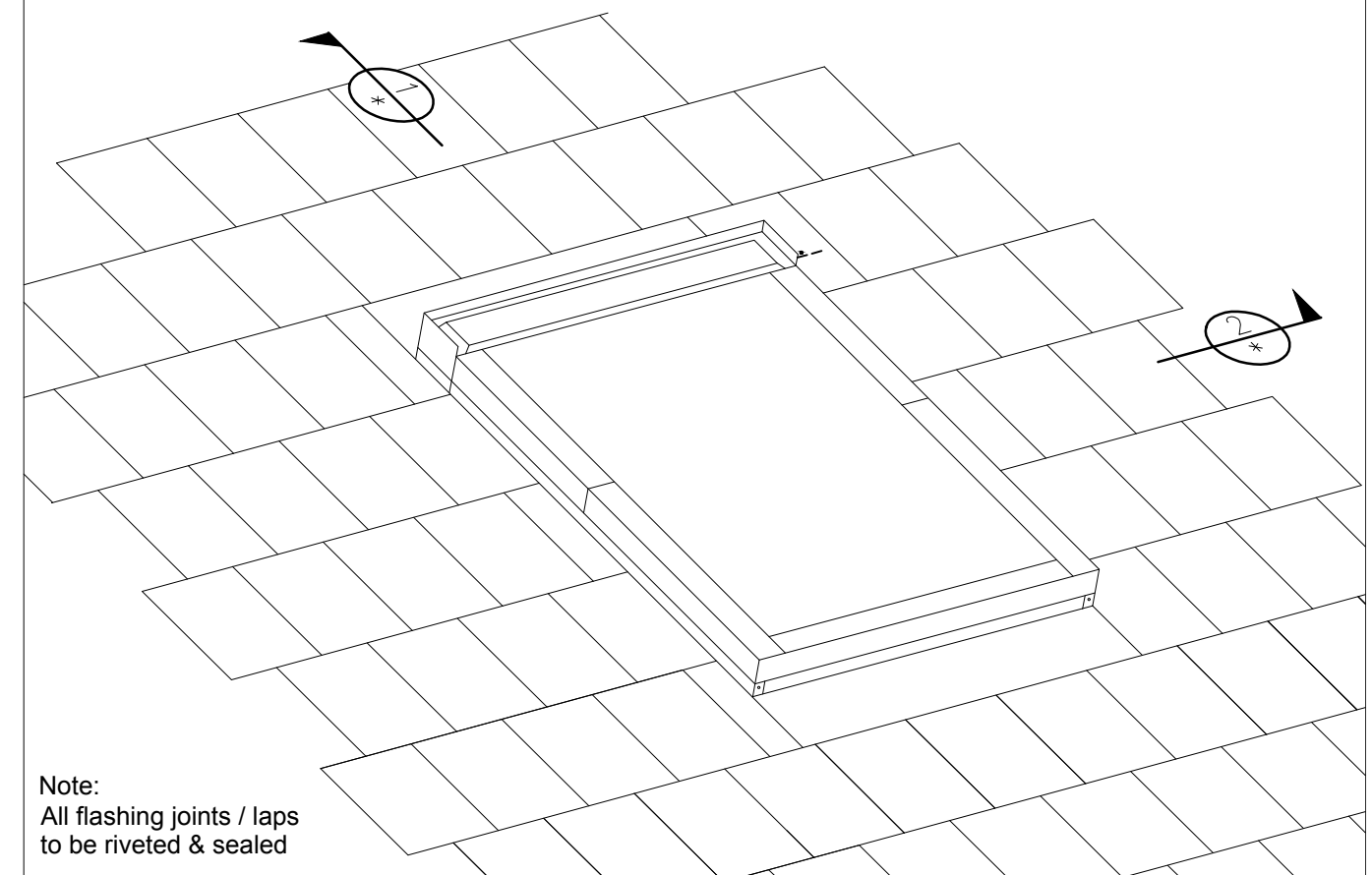

Not to scale, do not scale from drawing. All details are generic in nature and should be read in conjunction with the roofing manufacturers' standard penetration details.

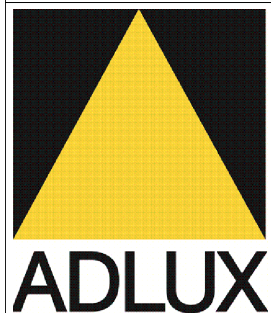

ADLUX Industries Ltd. ©
 36 Olive Road, Penrose
 P.O. Box 13866, Auckland
 New Zealand.
 Ph: (09) 636 6866
 Fax: (09) 636 6846
 Email: sales@adlux.co.nz

CENTRE PIVOT SLATE / SHINGLE ROOFING TILE PITCH 15° TO 60°



DATE: 20/04/19

DWG No: CP-SL/SH-SRF