

Stria™ Cladding

Hardie™ CLD™

Structural

Cavity Batten

Technical Specification

August 2022 New Zealand

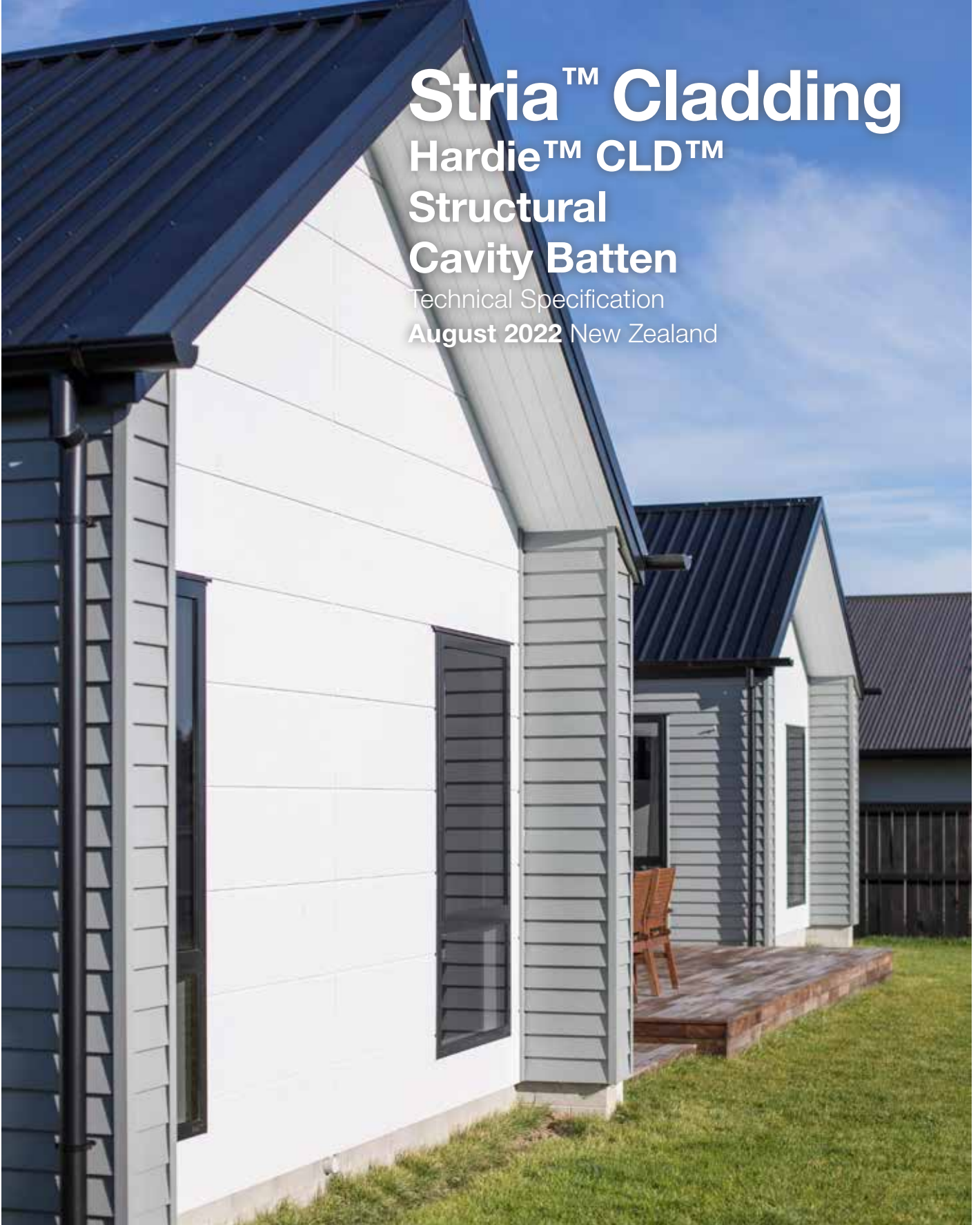

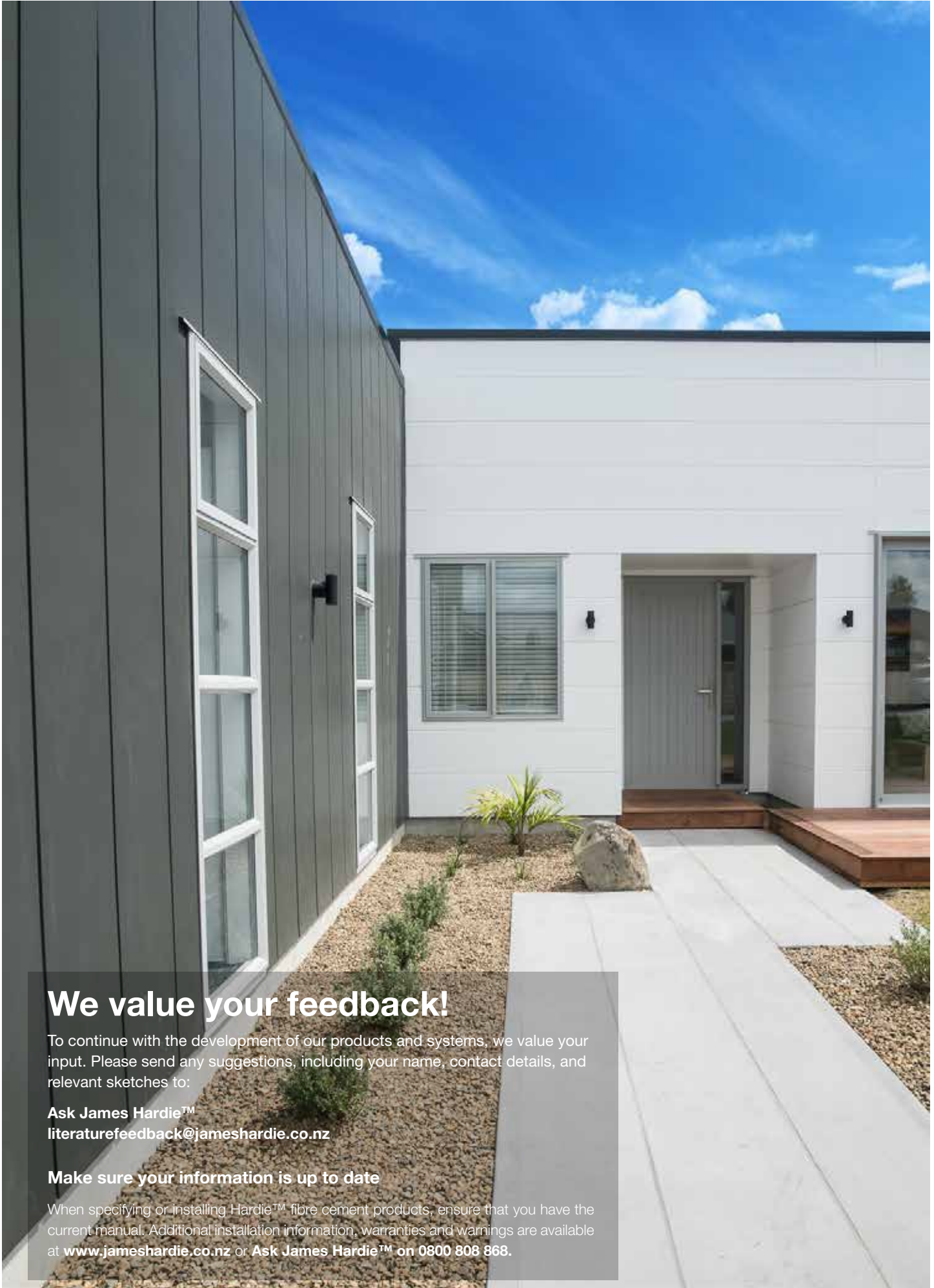

We value your feedback!

To continue with the development of our products and systems, we value your input. Please send any suggestions, including your name, contact details, and relevant sketches to:

Ask James Hardie™
literaturefeedback@jameshardie.co.nz

Make sure your information is up to date

When specifying or installing Hardie™ fibre cement products, ensure that you have the current manual. Additional installation information, warranties and warnings are available at www.jameshardie.co.nz or **Ask James Hardie™ on 0800 808 868.**

Contents

1	Product Overview	4	6	Installation	17
1.1	Product Information	4	6.1	Fasteners	17
1.2	Manufacturing and Classification	4	6.1.1	Fastener – Size and Layout	17
1.3	Components and Accessories	5	6.1.2	Fastening Method – T-Head Nails with Adhesive	17
2	Application and Scope	8	6.1.3	Fastener Durability	18
2.1	Application	8	6.2	Framing	18
2.2	Scope	8	6.2.1	Special Framing Requirements	18
2.3	Details	9	6.2.2	Tolerances	18
2.4	Specific Design	9	6.2.3	Frame Construction	18
3	Compliance	9	6.3	Flexible Underlay or HomeRAB™ Pre-Cladding	19
3.1	NZBC Compliance	9	6.4	Intermediate Support for Flexible Underlays	19
4	Design	10	6.5	RAB™ Board	19
4.1	Responsibility	10	6.6	Flashings	19
4.2	Site and Foundation	10	6.7	Cavity Closure/Vent Strip	20
4.3	Clearances	10	6.8	Hardie™ CLD™ Structural Cavity Battens	20
4.4	Moisture Management	10	6.9	Joints	20
4.5	Structure	11	6.9.1	Vertical Joint	20
4.5.1	Timber Framing	11	6.9.2	Horizontal Joint	20
4.5.2	Dimensions	11	6.9.3	Drainage Joint	20
4.5.3	Structural Grade	11	6.9.4	External Corner Joint	20
4.5.4	Durability	11	6.9.5	Internal Corner Joint	20
4.6	Wind Pressures	11	6.10	Junctions and Penetrations	21
4.7	Structural Bracing	11	7	Finishes	21
4.8	Energy Efficiency	11	7.1	Preparation	21
4.9	Fire Rated Walls	12	7.2	Painting	21
4.10	Control of External Fire Spread	12	7.3	Flexible Sealant	21
4.11	Durability	12	8	Care and Maintenance	22
4.12	Alpine Regions	12	9	Details Section Index	23
5	Safe Working Practices	13	Product Warranty	59	
5.1	Storage and Delivery	15			
5.2	Tips for Safe and Easy Handling of Stria™ Cladding	16			

1 Product Overview

1.1 Product Information

Stria™ Cladding is an external cladding system.

This specification is for use for the horizontal installation of Stria™ Cladding installed to Hardie™ CLD™ Structural Cavity Batten.

Stria™ Cladding installed to Hardie™ CLD™ Structural Cavity Battens as per this specification gives a panelised appearance on building facades. Stria™ Cladding can be fixed to either timber or lightweight steel-framed external walls. A wide range of colours can be used varying from light to dark. Stria™ Cladding is available in 325 or 405mm widths in 2700 and 4200mm lengths and is 14mm thick.

Table 1

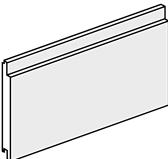
Stria™ Cladding information					
Product	Description	Size (mm)			Code
		Thickness	Length	Width	
	<p>Stria™ Cladding</p> <p>A 14mm profiled panel for expressed jointed residential facades. Factory sealed on all six sides. Each panel has a manila white colour primer applied on its face, which accepts a wide range of paint finishes.</p>	14	4200	405 325	<p>404263</p> <p>404063</p>

Note: All dimensions and masses provided are approximate only and subject to manufacturing tolerances. Stria™ Cladding has a mass of 16kg/m² at EMC. Stria™ Cladding is defined as a Light Weight Wall Cladding (not exceeding 30kg/m²) as per NZS 3604.

1.2 Manufacturing and Classification

Stria™ Cladding is an advanced lightweight cement composite cladding manufactured using a basic composition of Portland cement, ground sand, cellulose fibre and water. The product is easily identified by the name 'Stria™ Cladding' printed on the back of the panels.

Hardie™ CLD™ Structural Cavity Batten is manufactured using a low density fibre cement formulation. The basic composition is Portland cement, ground sand, cellulose fibre, water and proprietary additives. The battens are factory sealed on all sides.

Stria™ Cladding and Hardie™ CLD™ Structural Cavity Batten products are manufactured in Australia to the Australian/New Zealand Standard AS/NZS 2908.2 'Cellulose-Cement Products' (ISO 8336 'Fibre-Cement Flat Sheet').

Stria™ Cladding is classified Type A, Category 2 in accordance with AS/NZS 2908.2 "Cellulose-Cement Products".

For Safety Data Sheets (SDS) visit www.jameshardie.co.nz or Ask James Hardie on **0800 808 868**.

1.3 Components and Accessories

Table 2



Accessories/tools supplied by James Hardie			
Accessories	Description	Size/Quantity	Code
	Hardie™ CLD™ Structural Cavity Batten 19mm x 70mm fibre cement cavity batten installed over rigid air barrier or a flexible underlay. Stria™ Cladding is fixed to the battens.	2450mm long	403870
	Hardie™ 14mm Internal Corner Flashing Anodised aluminium extrusion used to create internal corners.	3000mm long	304871
	Hardie™ 14mm Cladding External Box Corner Anodised aluminium extrusion with wings used to create external corners.	2700mm long 4000mm long	305824 305823
	Hardie™ 14mm Aluminium Window Jamb Flashing Aluminium moulding used beside window opening to end butt the Stria™ Cladding.	3000mm long	305430
	Hardie™ 28mm Aluminium Cavity Closure Aluminium moulding used as vermin proofing.	3000mm long	305431
	Hardie™ 9mm Panel Aluminium External Box Corner A box corner mould to form the external joints. 9mm etch primed.	2450mm long 2750mm long 3000mm long 4000mm long	304509 304510 305150 305808
	uPVC Vent Strip PVC moulding used as vermin proofing.	3000mm long	302490
	Trimline Horizontal Jointer A jointer to cover the butt joint of Stria trimline joint flashing	Each	305871
	Hardie™ 14mm Aluminium Trimline Joint Flashing Etch prime aluminium extrusion used behind cladding of vertical joints.	3000mm long	305827

Table 2 cont...











Accessories/tools supplied by James Hardie			
Accessories	Description	Size/Quantity	Code
	Vertical Joint Flashing Etch prime aluminium extrusion used behind cladding of vertical joints.	3000mm long	305507
	Trimline External Corner Jointer Joins trimline joint flashing at an external corner.	Each	305870
	Trimline Internal Corner Jointer Joins trimline joint flashing at an internal corner.	Each	305872
Tools			
	Hardie™ Blade Saw Blade Diamond tip fibre cement circular saw blade. Spacers not included.	184mm 254mm	300660 303375

Table 3

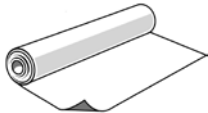
Accessories/tools not supplied by James Hardie

James Hardie recommends the following products for use in conjunction with Stria™ Cladding, HomeRAB™ Pre-Cladding and RAB™ Board. James Hardie does not supply these products and does not provide a warranty for their use. Please contact component manufacturer for information on their warranties and further information on their products.

Product	Description
	<p>Flexible Underlay Must comply with Table 23 of E2/AS1.</p>
	<p>Flexible Window Opening Flashing Tape A flexible self-adhesive tape used in preparation of a window. Refer to the window installation section in this manual for more information. e.g. Marshall Innovations: 0800 776 9727 3M™: 0800 474 787</p>
	<p>Adhesive Sealant Sikaflex® 11FC Polyurethane adhesive sealant manufactured by Sika® for applying between the panels and battens. Refer to section 6 for more information. SIKKA 0800 SIKANZ. 'Seal N Flex-1™' Polyurethane adhesive sealant manufactured by Bos0tik® for applying between the panels and battens. Refer to section 7 for more information. Bostik®: AKL: (09) 579 6253, WGTN: (04) 567 5119, CHCH: (03) 366 2583.</p>
	<p>Flexible Sealant Required to seal the vertical joints. Bostik® Seal N Flex-1™, Sikaflex® AT Facade, Sikaflex® MS or similar.</p>
	<p>30 x 1.6mm C Series Brad Nails 304SS brad nails used to install Stria™ Cladding to the Hardie™ CLD™ Structural Cavity Batten. Used in a straight bradder. Paslode®: (09) 477 3000</p>
	<p>65 x 2.87mm RoundDrive Ring Shank Nail For fixing Hardie™ CLD™ Structural Cavity Battens to the framing. Paslode®: (09) 477 3000</p>
	<p>200mm wide Polypropylene DPC Tape Product used over flexible underlay at external and internal corners.</p>

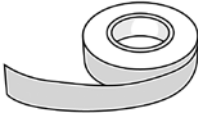
2 Application and Scope

2.1 Application

Stria™ Cladding can be fixed to either timber or lightweight steel-framed external walls.

For fixing to a steel frame. Ask James Hardie on **0800 808 868** for specific requirements. Or refer to the Steel Frame Technical Supplement by James Hardie about the installation of Stria™ Cladding to steel frame.

Specifiers

If you are a specifier or other responsible party for a project ensure that the information in this document is appropriate for the application you are planning and that you undertake specific design and detailing for areas which fall outside the scope of these specifications.

Installers

If you are an installer ensure that you follow the design, moisture management principles, associated figures and material selection provided by the designer and this Technical Specification. All the details provided in this document must be read in conjunction with the project specification.

Make sure your information is up to date

When specifying or installing products from James Hardie, ensure that you have the current manual. Additional installation information, warranties and warnings are available at www.jameshardie.co.nz or Ask James Hardie™ on **0800 808 868**.

2.2 Scope

This specification covers the installation of Stria™ Cladding within the following scope:

- The Stria™ Cladding must be installed horizontally.
- An external wall structure that complies with the Building Code or for an existing building, where the designer and/or installer has established that the external wall is suitable for the intended building work.
- In wind zones up to and including Extra High, or to a designed wind pressure of 2.5kPa (ULS) regardless of the building height. In wind zones greater than Very High a rigid air barrier must be used.
- A drained horizontal flashing break must be installed at intervals of no greater than 3.5m vertical height where the following applies;
 - on buildings with building height greater than 10m, and
 - where upper floors contain sleeping uses or other property
- On buildings greater than 10m in building height a RAB™ Board must be used.
- On buildings of any proximity to a relevant boundary. Within 1m of a relevant boundary a RAB™ Board must be used

Note: Refer to Stria™ Cladding Timber Cavity Batten technical specification when fixing to timber cavity battens or Stria™ Cladding Vertical Installation technical specification where installing Stria™ Cladding vertically.

2.3 Details

Various Stria™ Cladding construction details using a flexible underlay are provided within this document. In addition to these, the construction details with RAB™ Board have also been developed and are available on our website. The construction details are available in dwg, dxf, jpg and pdf file format and can be downloaded at www.jameshardie.co.nz.

Note: All dimensions shown are in millimetres unless noted otherwise.

2.4 Specific Design

For use of the Stria™ Cladding on specific design projects, the designer, architect or engineer must ensure that all clauses of the NZBC have been considered and a specific design has been undertaken for the areas which fall outside the scope of this literature.

3 Compliance

3.1 NZBC Compliance

Stria™ Cladding installed in accordance with this specification has been tested to demonstrate compliance with clauses E2, B1, B2 and F2 of the NZBC.

When installed in accordance with the conditions of CodeMark number GM-CM30109 Stria™ Cladding complies with all relevant requirements of the NZBC. Please refer to www.building.govt.nz for a copy of the certificate.



Stria™ Cladding Hardie™ CLD™ Structural Cavity Batten installation also has a BRANZ Appraisal number 1224 (2022) available at www.branz.co.nz or www.jameshardie.co.nz

4 Design

4.1 Responsibility

The specifier or other party responsible for the project must ensure that the information and details in this specification are appropriate for the intended application and that additional detailing is performed for specific design or any areas that fall outside the scope of this technical specification. For applications outside the scope of this literature and details, which are not provided herein, the architect, designer or engineer must undertake specific design and it should be ensured that the intent of their design meets the requirements of the NZBC.

All New Zealand Standards referenced in this manual are current editions and must be complied with.

James Hardie conducts stringent quality checks to ensure that any product manufactured falls within our quality spectrum. It is the responsibility of the builder to ensure that the product meets aesthetic requirements before installation. James Hardie will not be responsible for rectifying obvious aesthetic surface variations following installation.

4.2 Site and Foundation

The site on which the building is situated must comply with E1/AS1 Surface Water Clause of the NZBC. Foundations design must comply with relevant regulations, standards and meet the requirements of the NZBC. The grade of adjacent finished ground must slope away from the building to avoid any possibility of water accumulation.

4.3 Clearances

The clearance between the bottom edge of the cladding and the paved/unpaved ground must comply with section 9.1.3 of E2/AS1. The finished floor level must also comply with these requirements. These clearances must be maintained throughout the life of the building.

Stria™ Cladding must overhang the bottom plate by a minimum of 50mm as required by E2/AS1.

Stria™ Cladding must maintain a minimum clearance of 100mm from paved ground, and 175mm from unpaved ground.

On the roofs and decks, the minimum clearance must be 50mm.

Do not install external cladding such that it may remain in contact with water or ground, refer to Figures 3 and 4.

4.4 Moisture Management

It is the responsibility of the specifier to identify moisture related risks associated with any particular building design.

Wall construction design must effectively manage moisture, considering both interior and exterior environments of the building, particularly in buildings that have a higher risk of wind driven rain penetration. The buildings should also be ventilated sufficiently to control moisture accumulation due to condensation especially in artificially cooled/heated buildings.

Walls shall include those provisions as required by External Moisture Clause E2/AS1 of the NZBC. In addition, all wall openings, penetrations, junctions, connections, window sills, heads and jambs must incorporate appropriate flashings for waterproofing. The other materials, components and installation methods used to manage moisture in external walls, must comply with the requirements of relevant standards and the NZBC. For further guidance on designing for weathertightness, refer to BRANZ Ltd. and the Ministry of Business, Innovation and Employment updates on the following websites respectively, www.branz.co.nz and www.building.govt.nz.

In addition, the following issues must also be considered:

- Sealant must be installed where detailed in this literature.
- Where the walls are higher than two storeys, it is necessary to provide a horizontal flashing after two floors to drain the cavity.
- The installation of smoke chimneys, pipe penetrations and other fixtures etc. must not track moisture into the wall or restrict the drainage of moisture to the exterior.

4.5 Structure

4.5.1 Timber Framing

Timber framing must be in accordance with NZS 3604 (Timber Framed Buildings) or designed as per specific engineering design. For timber frame walls longer than 12m, it is best practice to allow for construction joints to accommodate movements, generated due to timber shrinkage or deflections.

4.5.2 Dimensions

A 45 x 90mm minimum framing size is required.

4.5.3 Structural Grade

Minimum timber grade must be in accordance with timber grades specified in NZS 3604.

4.5.4 Durability

The external framing timber must be treated to a minimum H1.2 treatment. Higher treatment levels may be used but check for the compatibility of treatment chemicals with other materials. Refer to the NZBC Acceptable Solution B2/AS1 Durability for further information about the durability requirements.

For timber treatment and allowable moisture content information refer to NZS 3602 (Timber and Wood-Based Products for use in Buildings) and NZS 3640 (Chemical Preservation of Round Sawn Timber) for minimum timber treatment selection and treatment requirements. Also refer to framing manufacturer's literature for further guidance on timber selection. Framing must be protected from moisture at sites in accordance with the framing manufacturer recommendations.

Note: Refer to NZS 3602 for information about the allowable moisture content in timber framing.

4.6 Wind Pressures

Stria™ Cladding is suitable for use in all New Zealand wind zones up to and including EH as defined in NZS 3604. Stria™ Cladding can also be used for specific engineering design projects up to wind pressures of 2.5kPa ULS.

4.7 Structural Bracing

Stria™ Cladding installed as per this specification cannot be used to achieve any structural bracing. However, bracing can be achieved by using RAB™ Board installed direct to framing instead of a flexible underlay or by using Villaboard™ Lining bracing system on the internal face. Refer to the Bracing Design Manual by James Hardie for further information.

4.8 Energy Efficiency

External walls constructed as per this technical specification, using Stria™ Cladding must use suitable bulk insulation to meet the minimum thermal insulation requirements as per Clause H1/AS1 'Energy Efficiency' of the NZBC.

4.9 Fire Rated Walls

A fire rating of up to 60 minutes can be achieved when using RAB™ Board in lieu of a flexible underlay and installing Stria™ Cladding as per this specification. Refer to the Fire and Acoustic Design Manual by James Hardie for further guidance on achieving fire ratings.

4.10 Control of External Fire Spread

Stria™ Cladding and Hardie™ CLD™ Structural Cavity Batten materials are classified as 'Type-A' as per Table C1.3 when tested to the requirements of Appendix C7.1.1 (b) of C/AS2 of the NZBC and is suitable for use where 'Non-Combustible Material' or 'Limited Combustibility Material' is required for use in buildings located anywhere in relation to the relevant boundary for building within the scope of C/AS1 or C/AS2.

- A drained horizontal flashing break must be installed at intervals of no greater than 3.5m vertical height where the upper floors contain sleeping uses or other property.
- On buildings greater than 10m in height a RAB™ Board must be used.

4.11 Durability

Stria™ Cladding is resistant to moisture induced deterioration (rotting) and meets the requirements of the following tests in accordance with the AS/NZS 2908.2:

- Heat Rain (Clause 6.5)
- Water Permeability (Clause 8.2.2)
- Warm Water (Clause 8.2.4)
- Soak Dry (Clause 8.2.5)

4.12 Alpine Regions

In regions subject to freeze/thaw conditions, Stria™ Cladding, HomeRAB™ Pre-Cladding, RAB™ Board and Hardie™ CLD™ Structural Cavity Battens must not be in direct contact with snow or ice build up for extended periods, e.g. external walls in alpine regions must be protected where snowdrifts over winter are expected.

These products have been tested in accordance with AS/NZS 2908.2 Clause 8.2.3.

5 Safe Working Practices

WARNING - DO NOT BREATHE DUST AND CUT ONLY IN WELL VENTILATED AREA

Hardie™ fibre cement products contain sand, a source of respirable crystalline silica

May cause cancer if dust from product is inhaled. Causes damage to lungs and respiratory system through prolonged or repeated inhalation of dust from product.

Intact fibre cement products are not expected to result in any adverse toxic effects. The hazard associated with fibre cement arises from the respirable crystalline silica present in dust generated by activities such as cutting, rebating, drilling, routing, sawing, crushing, or otherwise abrading fibre cement, and when cleaning up, disposing of or moving dust.

When doing any of these activities in a manner that generates dust, follow James Hardie instructions and best practices to reduce or limit the release of dust.

If using a dust mask or respirator, use an AS/NZS 1716 P1 filter and refer to Australian/New Zealand Standard 1715:2009 Selection, Use and Maintenance of Respiratory Protective Equipment for more extensive guidance and more options for selecting respirators for workplaces. For further information, refer to our installation instructions and Safety Data Sheets available at www.jameshardie.co.nz.

FAILURE TO ADHERE TO OUR WARNINGS, SAFETY DATA SHEETS, AND INSTALLATION INSTRUCTIONS MAY LEAD TO SERIOUS PERSONAL INJURY OR DEATH.

Crystalline Silica is

- Commonly known as sand or quartz
- Found in many building products e.g. concrete, bricks, grout, wallboard, ceramic tiles, and all fibre cement materials

Why is Crystalline Silica a health hazard?

- Silica can be breathed deep into the lungs when present in the air as a very fine (respirable) dust
- Exposure to silica dust without taking the appropriate safety measures to minimise the amount being breathed in, can lead to a potentially fatal lung disease – silicosis – and has also been linked with other diseases including cancer. Some studies suggest that smoking may increase these risks
- The most hazardous dust is the dust you cannot see!

When is Crystalline Silica a health hazard?

- It's dangerous to health if safety protocols to control dust are not followed when cutting, drilling or rebating a product containing crystalline silica and when cleaning up
- Products containing silica are harmless if intact (e.g. an un-cut sheet of wall board)

Avoid breathing in crystalline silica dust

Safe working practices

- ✗ NEVER use a power saw indoors or in a poorly ventilated area
- ✗ NEVER dry sweep
- ✓ ALWAYS use M Class or higher vacuum or damp down dust before sweeping up
- ✗ NEVER use grinders
- ✓ ALWAYS use a dust reducing circular saw equipped with a sawblade specifically designed to minimise dust creation when cutting fibre cement – preferably a sawblade that carries the Hardie™ Blade name or one with at least equivalent performance – connected to an M Class or higher vacuum
- ✓ Before cutting warn others in the area to avoid dust
- ✓ ALWAYS follow tool manufacturers' safety recommendations
- ✓ ALWAYS expose only the minimum required depth of blade for the thickness of fibre cement to be cut
- ✓ ALWAYS wear a properly-fitted, approved dust mask or respirator P1 or higher in accordance with applicable government regulations and manufacturer instructions
- ✓ Consider rotating personnel across cutting tasks to further limit respirable silica exposures.

When cutting Stria™ Cladding:

- ✓ Work outdoors only
- ✓ Make sure you work in a well ventilated area
- ✓ Position cutting station so wind will blow dust away from yourself and others in the working area
- ✓ Rotate employees across cutting task over duration of shift
- ✓ Cut products with a Hardie™ Blade Saw Blade (or equivalent) and a dust reducing circular saw connected to a M Class or higher vacuum
- ✓ When sawing, sanding, rebating, drilling or machining fibre cement products, always:
 - Wear your P1 or higher (correctly fitted in accordance with manufacturers' instructions), ask others to do the same.
 - Keep persons on site at least 2 metres and as far as practicable away from the cutting station while the saw is in operation
 - If you are not clean shaven, then use a powered air respirator with a loose fitting head top
 - Wear safety glasses
 - Wear hearing protection
- ✓ Make sure you clean up BUT never dry sweep. Always hose down with water/wet wipe or use an M Class or higher vacuum

If concern still exists about exposure levels or you do not comply with the above practices, you should always consult a qualified industrial hygienist or contact James Hardie for further information.

Working Instructions

Hardie™ Blade Saw Blade

The Hardie™ Blade Saw Blade used with a dust-reducing saw is ideal for fast, clean cutting of Hardie™ fibre cement products. A dust-reducing saw uses a dust collector connected to a M Class or higher vacuum. When sawing, clamp a straight edge to the sheet as a guide and run the saw base plate along the straight edge when making the cut.

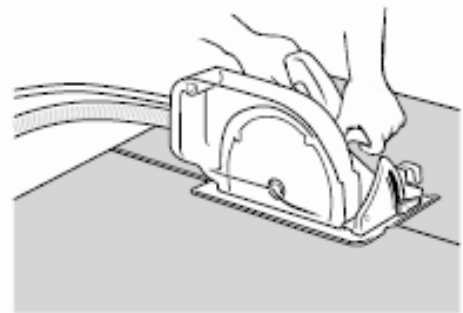

Hole-Forming

For smooth clean cut circular holes:

- Mark the centre of the hole on the sheet
- Pre-drill a 'pilot' hole
- Using the pilot hole as a guide, cut the hole to the appropriate diameter with a hole saw fitted to a heavy duty electric drill



For irregular holes:

- Small rectangular or circular holes can be cut by drilling a series of small holes around the perimeter of the hole then tapping out the waste piece from the sheet face
- Tap carefully to avoid damage to sheets, ensuring that the sheet edges are properly supported

5.1 Storage and Delivery

Keeping products and people safe

Off loading

- ✓ Hardie™ fibre cement products should be off-loaded carefully by hand or by forklift
- ✓ Hardie™ fibre cement products should not be rolled or dumped off a truck during the delivery to the jobsite

Storage

Hardie™ fibre cement products should be stored:

- ✓ In their original packaging
- ✓ Under cover where possible or otherwise protected with a waterproof covering to keep products dry
- ✓ Off the ground – either on a pallet or adequately supported on timber or other spacers
- ✓ Flat so as to minimise bending

Hardie™ fibre cement products must not be stored:

- ✗ Directly on the ground
- ✗ In the open air exposed to the elements

James Hardie is not responsible for damage due to improper storage and handling.

5.2 Tips for Safe and Easy Handling of Stria™ Cladding

- ✗ Do not lift planked products flat and in the middle
- ✓ Carry the products on the edge
- ✓ If only one person is carrying the product, hold it in the middle and spread arms apart to better support the product
- ✓ If two people are carrying the plank, hold it near each end and on edge
- ✓ Exercise care when handling planked products to avoid damaging the edges/corners

6 Installation

Stria™ Cladding is installed horizontally using the cavity construction method as per the details and information published in this document. Stria™ Cladding panels are 325mm or 405mm wide and are installed with a 25mm nominal lap over the panel below. Considering the installation and machining tolerances, the effective cover for Stria™ Cladding can vary between 300 to 302mm or 380 to 382mm respectively.

Stria™ Cladding and Hardie™ CLD™ Structural Cavity Battens must be kept under cover whilst in storage or at sites and they must be dry at the time of their installation. All site cut panel edges must be sealed with Dulux® 1 Step, Resene® Quick Dry, Taubmans® Underproof Acrylic Primer Undercoat or similar sealer compatible with the finish coat before installation.

Stria™ Cladding must be fully supported and fixed into Hardie™ CLD™ Structural Cavity Battens. Ensure that cladding is hard against the battens to avoid drumminess. To achieve best aesthetic results it is recommended to position the vertical jointer by the corner of openings or coinciding with the centre line of openings. This technical specification only covers the horizontal installation of Stria™ Cladding on Hardie™ CLD™ Structural Cavity Battens. See the Stria™ Cladding technical manual for vertical installation on timber cavity batten.

6.1 Fasteners

6.1.1 Fastener – Size and Layout

Hardie™ CLD™ Structural Cavity Batten must be fixed to the studs with fasteners as per Table 4. The fasteners must be driven at a minimum distance of 50mm from the batten ends.

Table 4

Fixing type	Wind pressure (kPa)	Hardie™ CLD™ Structural Cavity Batten spacing Max. (mm)	Fixing centres (mm)
65 x 2.8mm RounDrive ring shank nail to timber frame	Up to 1.5 (up to and including VH)	600 or 400 as per framing spacing	250
	1.5 to 2.5	400 as per framing spacing	200

- For fastener durability information, refer to Clause 6.1.3 of this document
 - Hardie™ CLD™ Structural Cavity Battens less than 400mm in length must have fixings at maximum 150mm centres
- For other fixing options Ask James Hardie on **0800 808 868**.

6.1.2 Fastening Method – T-Head Nails with Adhesive

The combination of stainless steel straight T-head nails and an adhesive sealant provides a fast and efficient panel installation method. Use minimum of three nails per stud for each panel, refer to Figure 1. Use Paslode® 30 x 1.6mm C Series Stainless Steel Brad Nails only.

Apply a 6mm thick continuous bead of Bostik® ‘Seal n Flex 1™’ or Sika® ‘Sikaflex® 11FC’ adhesive sealant to the face of the Hardie™ CLD™ Structural Cavity Batten prior to fixing Stria™ Cladding. Only apply adhesive sealant to the Hardie™ CLD™ Structural Cavity Battens to suit each panel as the Stria™ Cladding is installed on the wall.

It is a good practice to set the brad nail gun to fire 2-3mm proud of the panel surface keeping a consistent pressure on the panel while fixing. Let the adhesive sealant go off for approximately 2 hours whilst continuing work on the next section of wall. Come back later and hammer the nails flush with cladding surface. The edge distance required for fixing T-head brad nails is 12mm, refer to Figure 6.

6.1.3 Fastener Durability

Fasteners used to fix Hardie™ CLD™ Structural Cavity Batten must meet the minimum durability requirements of the NZBC. NZS 3604 specifies the requirements for fixing material to be used in relation to exposure conditions and are summarised in Table 5.

Fasteners must be fully compatible with all other materials that they are to be in contact with to ensure the durability and integrity of assembly. For steel framing ensure that the fasteners used are compatible with steel framing. Contact fastener manufacturers for more information.

Table 5 Exposure conditions and nail selection prescribed by NZS 3604

Zone	Application	
D (Sea Spray) *	General	Stainless Steel 304/316
	Fire	
	Bracing	
C and B and Geothermal hot spots	General	Hot Dip Galvanised **
	Fire	
	Bracing	

* Zone C areas where local knowledge dictates that increased durability is required, appropriate selection shall be made Microclimate conditions as detailed in NZS 3604, Paragraph 4.2.4 require SED.

**Hot dip galvanised must comply with AS/NZS 4680.

Also refer to the NZBC Acceptable Solution E2/AS1 Table 20 and 21 for information regarding the selection of suitable fixing materials and their compatibility with other materials.

6.2 Framing

Stria™ Cladding can be fixed either to a timber-frame or steel-frame.

For fixing to a steel frame. Ask James Hardie on **0800 808 868** for specific requirements.

6.2.1 Special Framing Requirements

The following are special framing requirements for both timber and steel framing:

- Double studs are required at internal corners, refer to Figure 11
- Extra packers maybe required at external corners

6.2.2 Tolerances

In order to achieve the required performance and an acceptable wall finish, it is imperative that framing is straight and true. Framing tolerances shall comply with Table 2.1 of NZS 3604 and the manufacturer's specifications. All framing shall be made flush.

6.2.3 Frame Construction

Use of timber framing must be in accordance with NZS 3604, specific engineering design (SED) and the framing manufacturer's instructions. The framing must be rigid and not rely on the cladding for stability. Timber framing minimum sizes and its set-out must comply with NZS 3604 and as specified in this technical specification.

The following framing is required:

- Studs provided at 600mm centres maximum
- Nogs provided at 800mm centres maximum
- When RAB™ Board/HomeRAB™ Pre-Cladding is used the nogs may be omitted if desired
- An extra stud is required in internal corners
- For EH and specific design projects exposed to wind speeds higher than 50m/sec, the stud spacing must be closed to 400mm centres.

In case of gable end trusses sitting on top plates of external wall frame, the frame size must be in accordance with truss design and specification supplied by the frame and truss manufacturer/supplier supported by independent design producer statement.

6.3 Flexible Underlay or HomeRAB™ Pre-Cladding

Flexible underlay/rigid air barrier eg: HomeRAB™ Pre-Cladding must be provided as per the requirements of External Moisture Clause E2 of the NZBC. The flexible underlay selected for use must comply with Table 23 of E2/AS1.

The flexible underlay must be fixed in accordance with section 9.1.7 E2/AS1 and underlay manufacturer's recommendations.

Walls which are not lined on the inside face e.g. garage walls or gable ends must include a rigid sheathing or an air barrier behind the cladding which complies with Table 23 of E2/AS1. HomeRAB™ Pre-Cladding complies with these requirements and is suitable for use in this situation. It must be installed in accordance with HomeRAB™ Pre-Cladding and RAB™ Board Installation Manual.

6.4 Intermediate Support for Flexible Underlays

Where studs are at 600mm centres an intermediate means of restraining the flexible underlay and insulation from bulging into the cavity shall be installed. An acceptable method to achieve this is using a:

- 75mm galvanised mesh
- Polypropylene tape at 300mm centres fixed horizontally and drawn taut

No intermediate supports are required:

- Studs are spaced at maximum 400mm centres
- Rigid air barriers instead of flexible underlay are used

6.5 RAB™ Board

With EH wind zone or for specific design wind zone, a rigid air barrier e.g. RAB™ Board must be used instead of flexible underlay as per E2/AS1 clause 9.1.7.2.

To achieve the temporary weathertightness using HomeRAB™ Pre-Cladding and RAB™ Board, windows/doors need to be temporarily installed. Refer to HomeRAB™ Pre-Cladding and RAB™ Board installation manual for information regarding its installation and to achieve temporary weathertightness.

6.6 Flashings

All wall openings, penetrations, intersections, connections, window sills, heads and jambs must be flashed prior to Stria™ Cladding installation. Refer to moisture management requirements in Clause 4.4. The flexible underlay/rigid air barrier must be appropriately incorporated with penetration and junction flashings using flashing tapes. Materials must be lapped in such a way that water tracks down to the exterior on the face of flexible underlay or rigid air barrier. James Hardie will assume no responsibility for water infiltration within the wall due to poor installation of flashings or flexible underlay.

The selected flashing materials must comply with the durability requirements of the NZBC. For information refer to Table 20 of E2/AS1.

When using HomeRAB™ Pre-Cladding and RAB™ Board the entire framing around openings must be sealed with a flashing tape. The tape must be finished over the face of the rigid air barrier. Refer to HomeRAB™ Pre-Cladding and RAB™ Board installation manual for further information.

6.7 Cavity Closure/Vent Strip

The Hardie™ 28mm Aluminium Cavity Closure or uPVC cavity vent strip must be installed at the bottom of all walls constructed using the drained and ventilated cavity construction method.

It is important that the openings in the cavity closure/uPVC vent strip are kept clear and unobstructed to allow free drainage and ventilation of cavities. Hardie™ 28mm cavity closure/uPVC vent strip has an opening area of 1000mm²/m length.

6.8 Hardie™ CLD™ Structural Cavity Battens

The Hardie™ CLD™ Structural Cavity Battens are suitable to have Stria™ Cladding fixed into them. The battens are 2450mm long, 70mm wide and 19mm thick and are fully sealed on all faces.

Hardie™ CLD™ Structural Cavity Batten must be fixed to the studs over flexible underlay or rigid air barrier. The battens are run continuously over the studs but they must have a gap at the floor joist level to allow for structural shrinkage and deflection in joists, refer to Figure 27 and 31.

The Hardie™ CLD™ Structural Cavity Batten can also be butt jointed over the studs within the floor height. The batten ends must be cut between 20°- 45° and be installed to deflect the moisture to exterior. The ends must be sealed and butted using an adhesive sealant in the joint, refer to Figure 2.

The minimum framing width required to fix Hardie™ CLD™ Structural Cavity Batten is 45mm, refer to Figure 7. All site cut ends of Hardie™ CLD™ Structural Cavity Battens must be sealed on site with Dulux® Acraprime® 501/1 sealer or Resene® Quick Dry before installation. Refer to Table 5 for Hardie™ CLD™ Structural Cavity Batten spacing and fixing size and fixing centres.

The designer must ensure that the Hardie™ CLD™ Structural Cavity Battens are not used in situations where design wind pressures are above 2.5kPa(ULS).

Hardie™ CLD™ Structural Cavity Battens must not be used to a length smaller than 300mm.

6.9 Joints

6.9.1 Vertical Joint

Stria™ Cladding can be jointed using a vertical joint flashing, refer to Figures 7 and 8.

6.9.2 Horizontal Joint

Stria™ Cladding panels are horizontally ship lapped over the panel below as per Figure 6. There is a minimum 25mm lap between the two panels. Ensure that Stria™ Cladding panels are securely interlocked before nailing. Stria™ Cladding can run continuous over floor joists without any horizontal joint when LVL timber floor joists, refer to Figure 27.

When an engineered joist or LVL joist is not used, a movement joint must be formed at floor joist, refer to Figure 28 or 31.

6.9.3 Drainage Joint

After every two floors a horizontal drainage joint flashing is required, refer to Figure 31.

6.9.4 External Corner Joint

A Hardie™ 14mm external box corner flashing is used to fix the external corners, refer to Figure 9.

Note: Fix all vertical mouldings at 400mm centres both sides.

6.9.5 Internal Corner Joint

A Hardie™ 14mm internal corner flashing is to be used to form an internal corner joint, refer to Figure 11.

6.10 Junctions and Penetrations

Refer to Clause 4.4 of this specification for moisture management requirements. All windows and doors must be detailed as per the requirements of this specification. James Hardie has developed the window details for Stria™ Cladding which meet the requirements of E2 External Moisture, an approved document of the NZBC, refer to Figures 16 to 26.

7 Finishes

7.1 Preparation

Where panels are fixed with brad nails, the nail heads must be finished flush with panel surface. The nail heads can be skimmed over with an exterior grade two part builders fill, if required. The skimmed area must be primed prior to painting.

7.2 Painting

Stria™ Cladding is pre-primed and is suitable for site applied acrylic paints. In order to seal cut edges or sanded patches, Dulux® 1 Step, Resene® Quick Dry, Taubmans® Underproof Acrylic Primer Undercoat or a similar product should be applied. The primer should be compatible with the paint to be used.

Painting of Stria™ Cladding is mandatory to meet the durability requirements of the NZBC and 25 year James Hardie product warranty. Stria™ Cladding must be dry and free of any dust or grime before painting. The panels must be painted within 90 days of their installation. There is no restriction on the LRV of paint to be applied on the Stria™ Cladding. For the best aesthetic results a low sheen paint is recommended.

James Hardie recommends a minimum of two coats of exterior grade acrylic paint. Follow the paint manufacturer's recommendations to prepare the surface and to adequately cover and conceal the panel fixings.

7.3 Flexible Sealant

Sealant used must comply with the relevant requirements of the NZBC. Their application and usage must be in accordance with the manufacturer's instructions. Check with the sealant manufacturer prior to coating over sealant. Some sealant manufacturers do not recommend coating over their product.

8 Care and Maintenance

The extent and nature of maintenance required will depend on the geographical location and exposure of the building. It is the responsibility of the specifier to determine normal maintenance requirements to maintain the effectiveness of the cladding.

As a guide, it is recommended that the basic normal maintenance tasks shall include, but not be limited to:

- Washing down exterior surfaces every 6 -12 months using low pressure water and a brush, and every 3 - 4 months in extreme coastal conditions or sea spray zones. Do not use a water blaster to wash down the cladding. Refer to your paint manufacturer for washing down requirements.
- Re-coating exterior protective finishes. Always refer to your paint manufacturer for re-coating requirements
- Regular inspection and repair if necessary of the cladding joints, sealants, nail head fillers
- Cleaning out gutters, down pipes and overflow pipes as required
- Pruning back vegetation which is close to or touching the building as well as ensuring the NZBC ground clearance requirements are maintained especially where gardens are concerned
- The clearance between the bottom edge of the Stria™ Cladding and the finished/unfinished ground must always be maintained.

9 Details Section Index

Description	Page
Figure 1: Framing set out	24
Figure 2: Batten fixing set out	25
Figure 6: Fixing detail Stria™ Cladding	28
Figure 7: Vertical jointing option	29
Figure 8: Vertical jointing option	29
Figure 9: External aluminium box corner option 1	30
Figure 11: Internal aluminium corner	31
Figure 12: Soffit detail	32
Figure 13: Nil soffit detail	33
Figure 14: Soffit detail top ventilation	34
Figure 15: Nil soffit detail top ventilation	35
Figure 16: Window sill	36
Figure 17: Window jamb	37
Figure 18: Window head with full cladding across head flashing	38
Figure 19: Window head with cladding cut around head flashing	38
Figure 20: Window head stop end	39
Figure 21: Trimline joint detail at window head	40
Figure 22: Trimline joint at window head	41
Figure 23: Window sill with facing	42
Figure 24: Window jamb with facing	43
Figure 25: Window head with facings	44
Figure 26: Door sill support detail	45
Figure 27: Continuous cladding over joist at floor level	46
Figure 28: Trimline joint flashing at floor level	47
Figure 29: Trimline joint flashing at external corner	48
Figure 30: Trimline joint flashing at internal corner	49
Figure 31: Drained flashing joint at floor level	50
Figure 32: Drained flashing at external corner	51
Figure 33: Pipe penetration	52
Figure 34: Apron flashing detail	53
Figure 35: Parapet flashing	54
Figure 36: Roof to wall junction detail	54
Figure 37: Garage head	55
Figure 38: Garage jamb	55
Figure 39: Cavity batten setout building height over 10m	56
Figure 40: Inter-tenancy fire separation	57

For all meter box details please visit our website at www.jameshardie.co.nz or Ask James Hardie on **0800 808 868**.

Figure 1: Framing set out

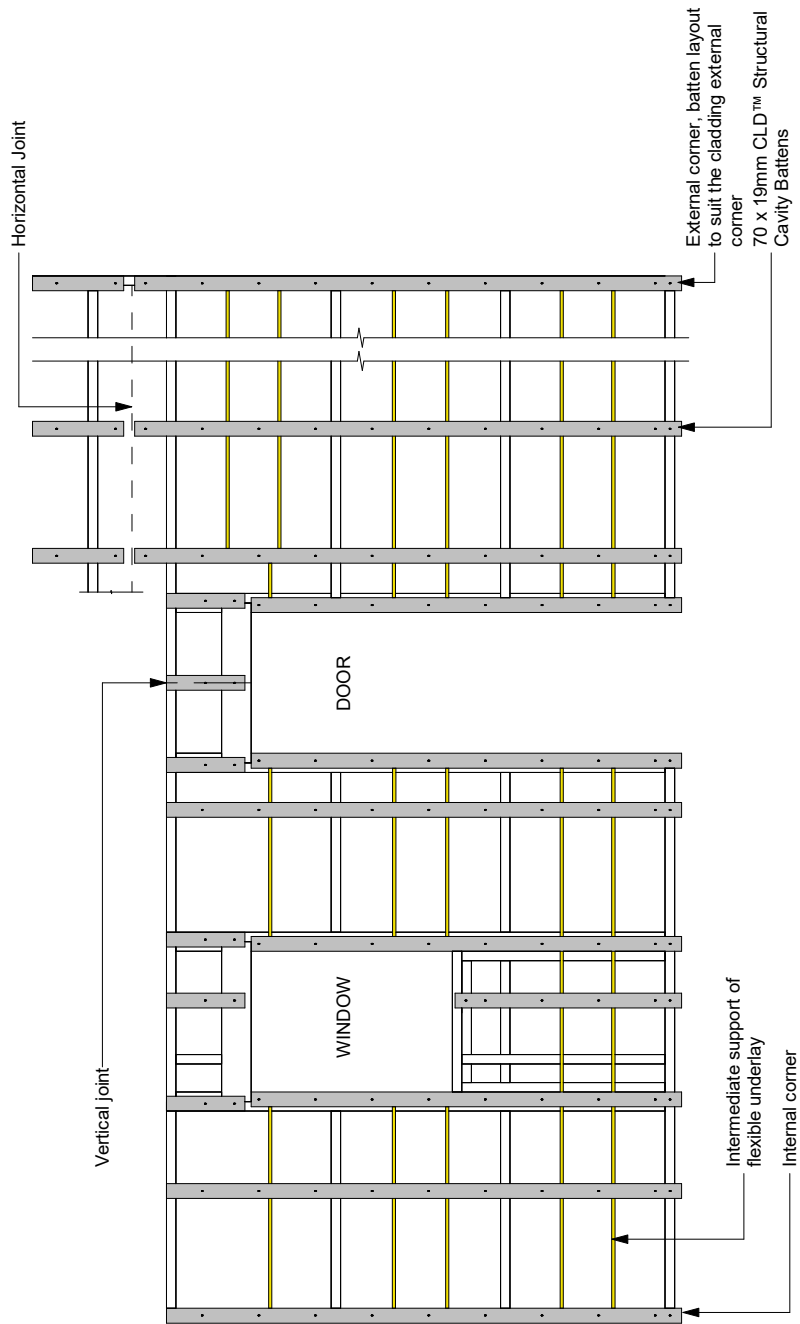

- Maximum stud spacing 600mm centres

Figure 2: Batten fixing set out

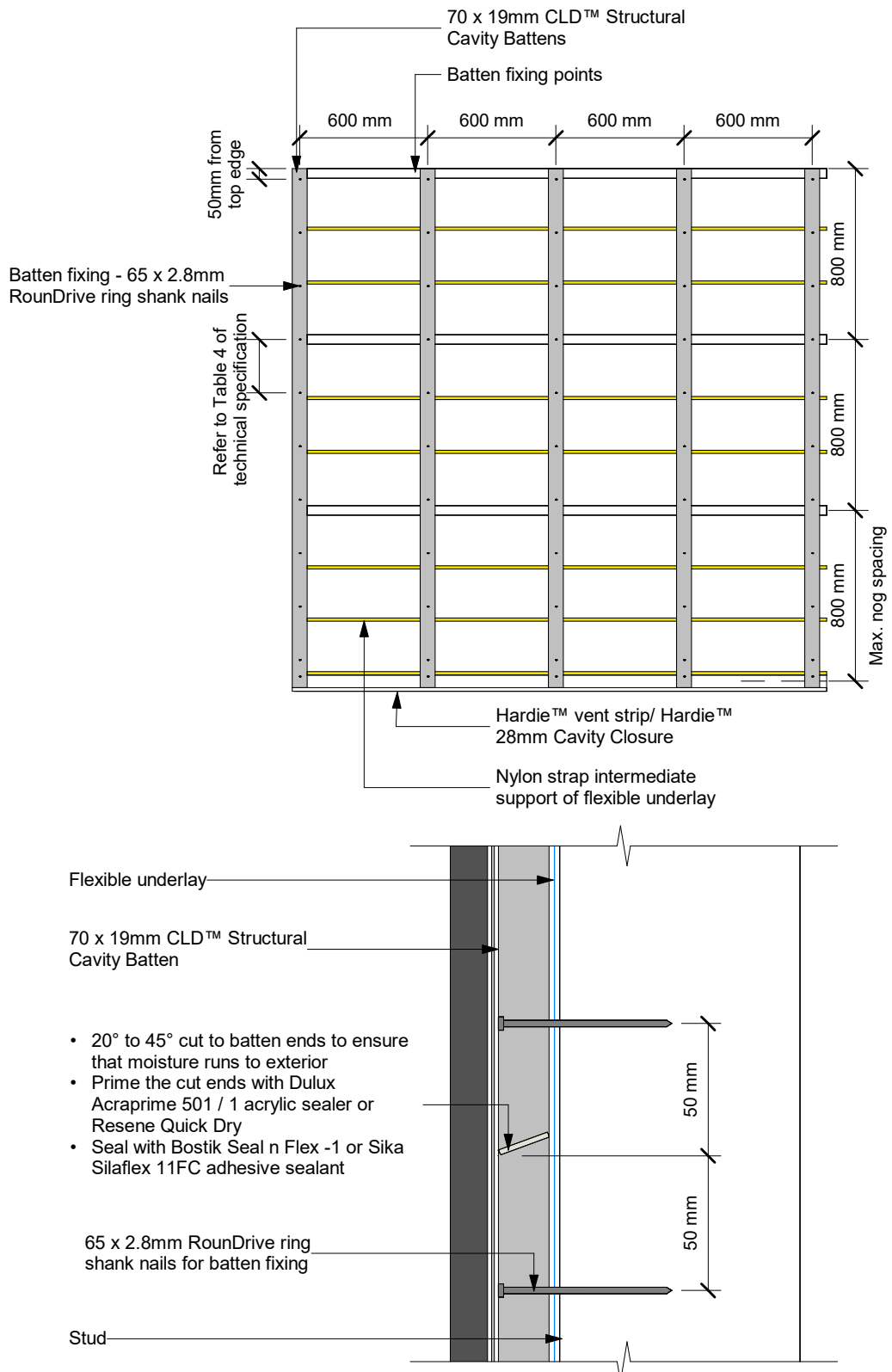
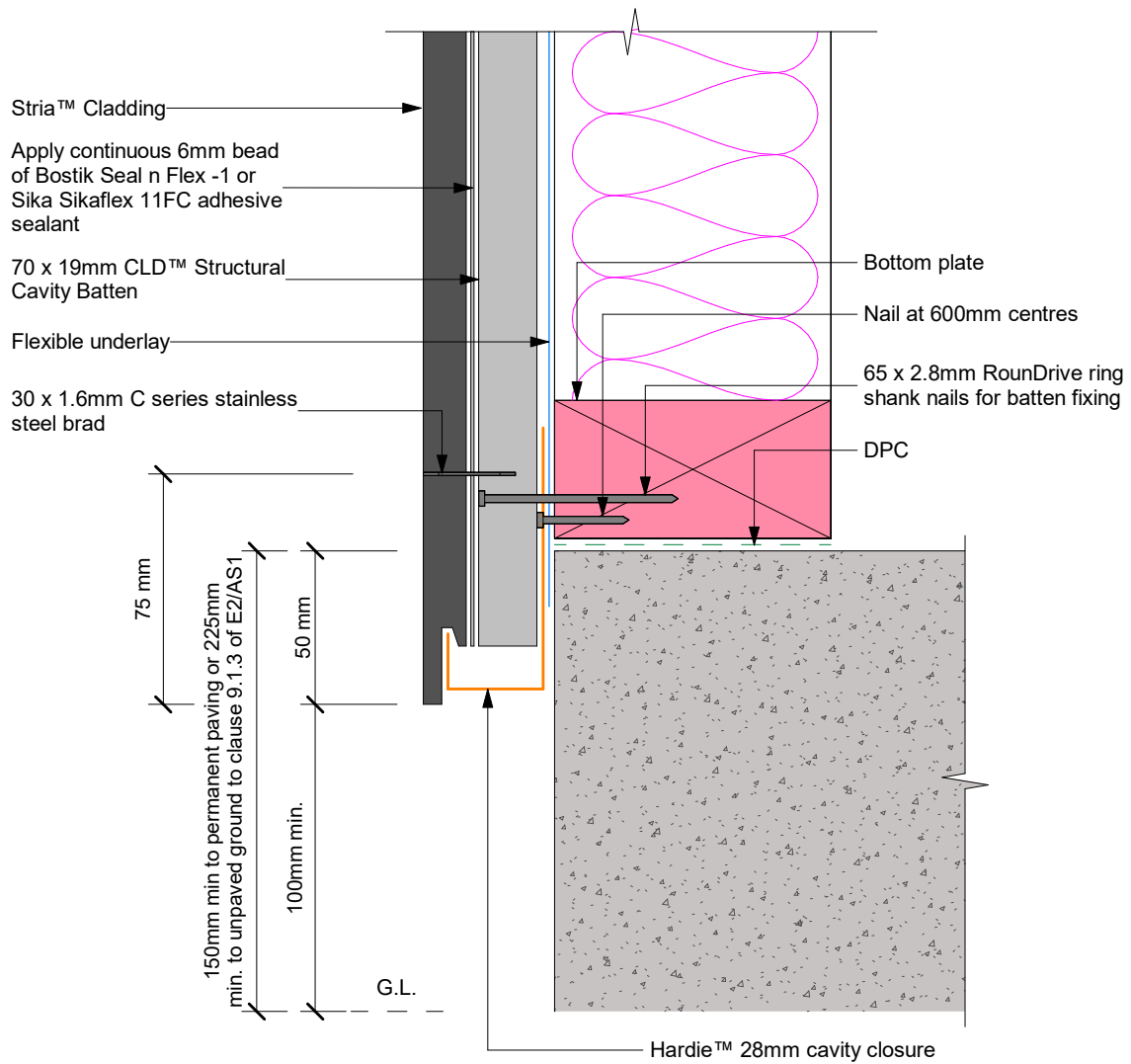
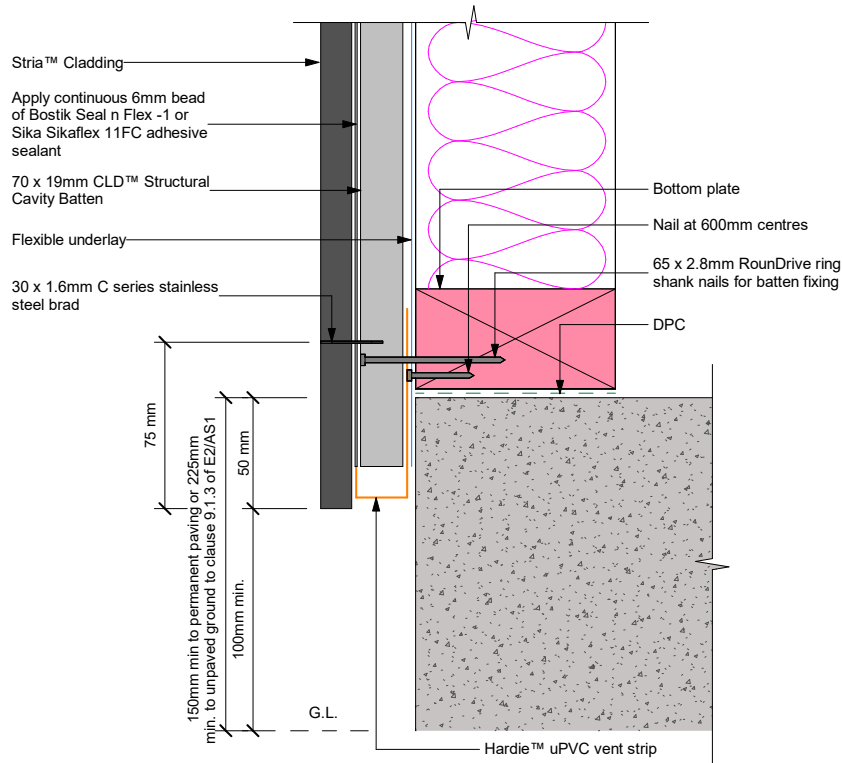

Figure 3: Foundation detail - Option 1



Note: Site cut edges to be primed

Figure 4: Foundation detail – option 2



NOTE: Site cut edges to be primed

Figure 5: Enclosed deck

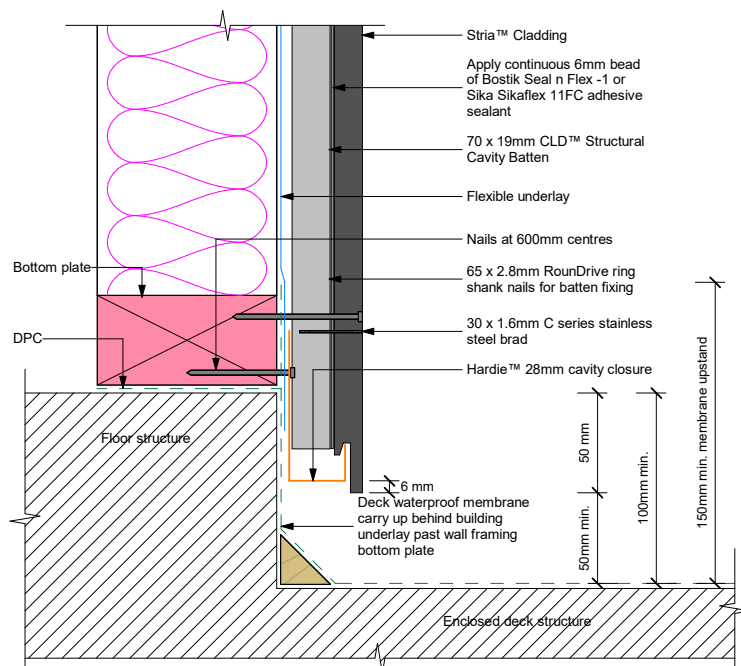

Figure 6: Fixing detail Stria™ Cladding

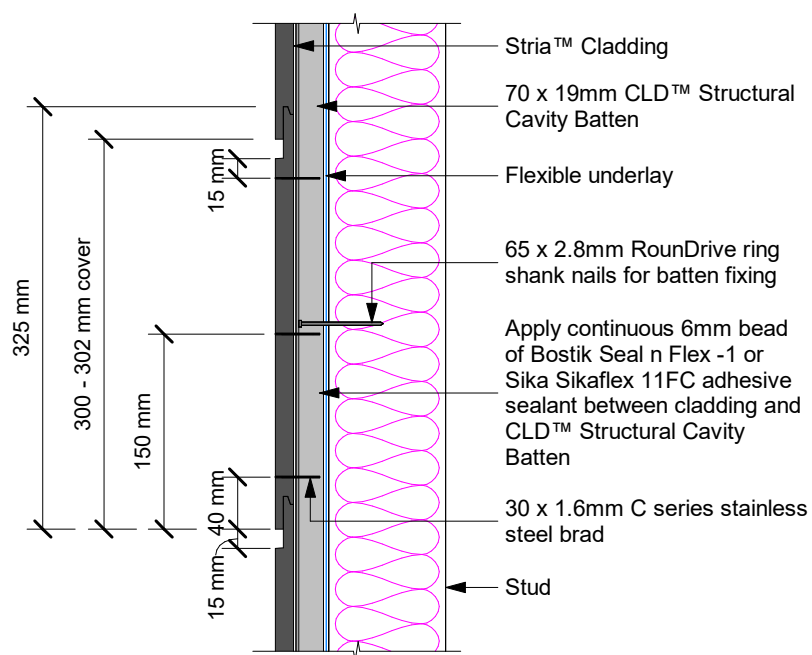
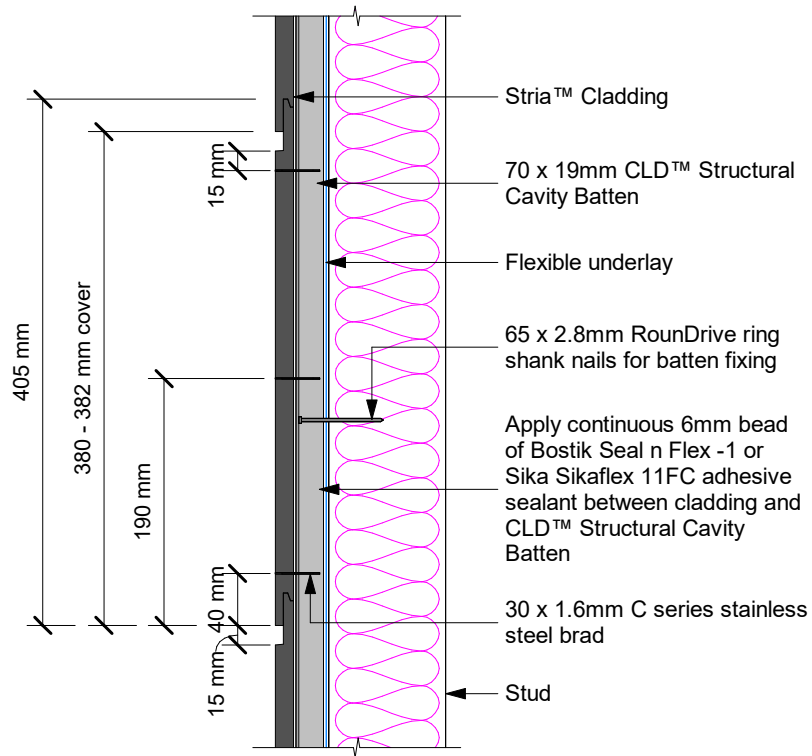

Figure 7: Vertical jointing option

Apply continuous 6mm bead of Bostik Seal n Flex -1 or Sika Sikaflex 11FC adhesive sealant

65 x 2.8mm RounDrive ring shank nails for batten fixing

Flexible underlay

70 x 19mm CLD™ Structural Cavity Batten

Hardie™ 14mm trimline flashing

4mm continuous bead of flexible sealant to end of Stria™ Cladding prior to butting to Hardie™ 14mm trimline joint

Stria™ Cladding

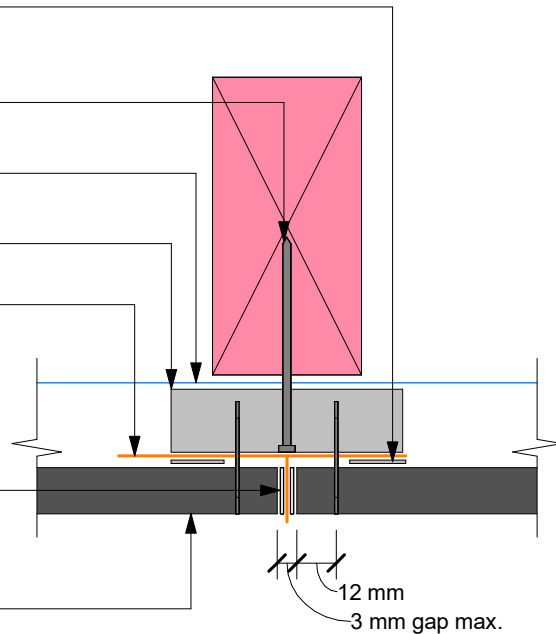

Figure 8: Vertical jointing option

65 x 2.8mm RounDrive ring shank nails for batten fixing

70 x 19mm CLD™ Structural Cavity Batten

Flexible underlay

Stria™ Cladding

Apply continuous 6mm bead of Bostik Seal n Flex -1 or Sika Sikaflex 11FC adhesive sealant

Apply continuous bead of flexible sealant in the corner

Stria™ vertical joint flashing

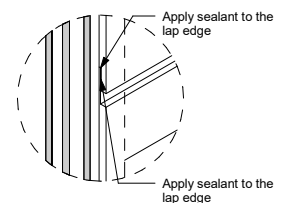
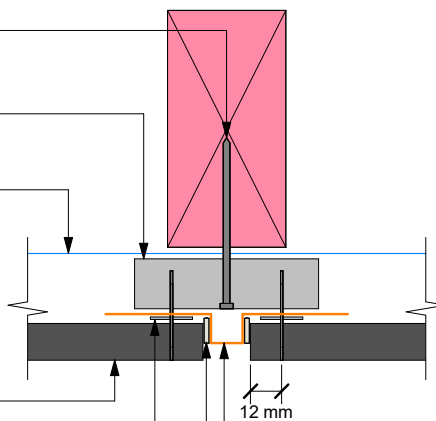

Enlarged Detail X

Note: Site cut edges to be primed

Notes:

- All site cut edges to be sealed

Figure 9: External aluminium box corner option 1

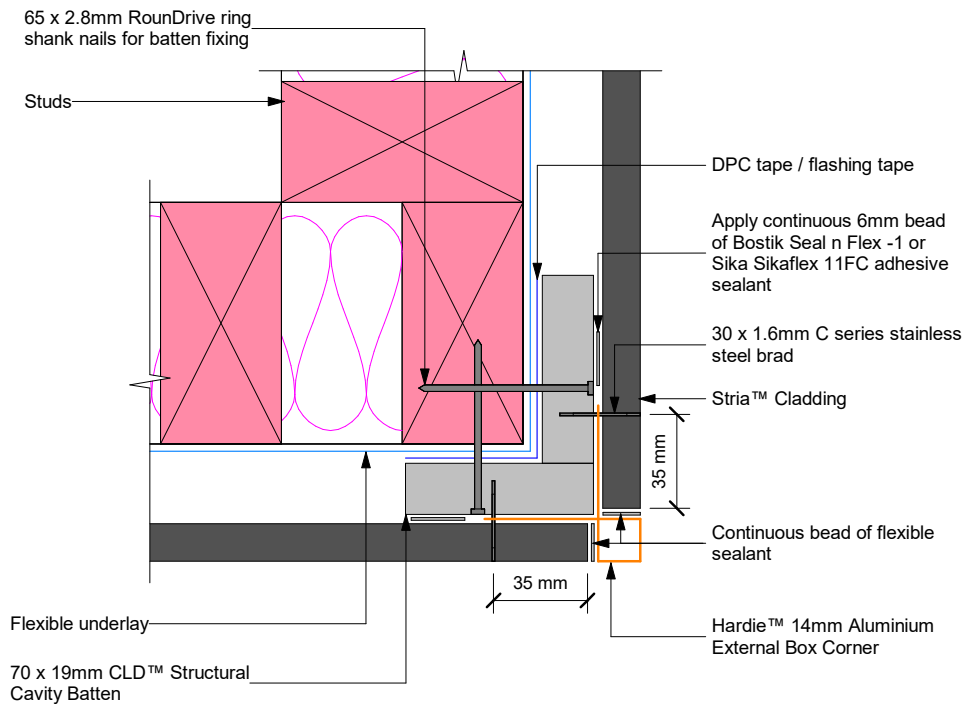

Note: Site cut edges to be primed

Figure 10: External aluminium box corner negative detail

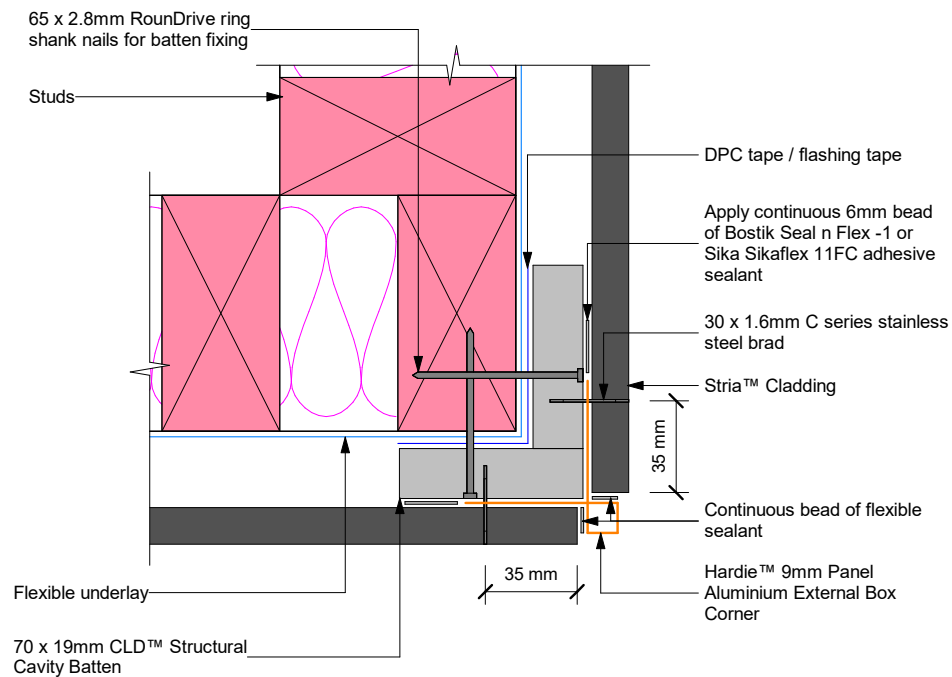

Note: Site cut edges to be primed

Figure 11: Internal aluminium corner

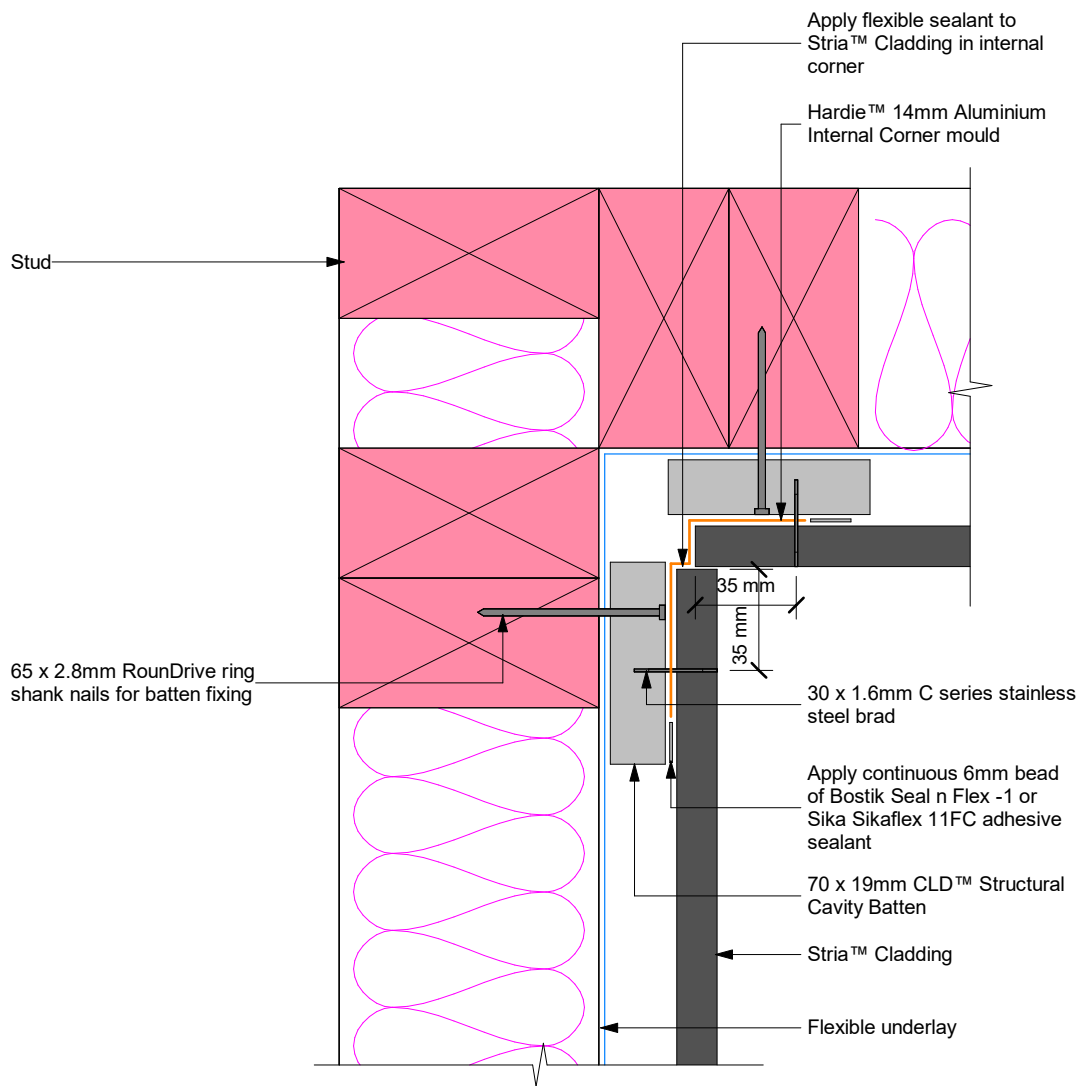

Note: Site cut edges to be primed

Note: All joint mouldings to be fixed at 400mm centres both sides.

Figure 12: Soffit detail

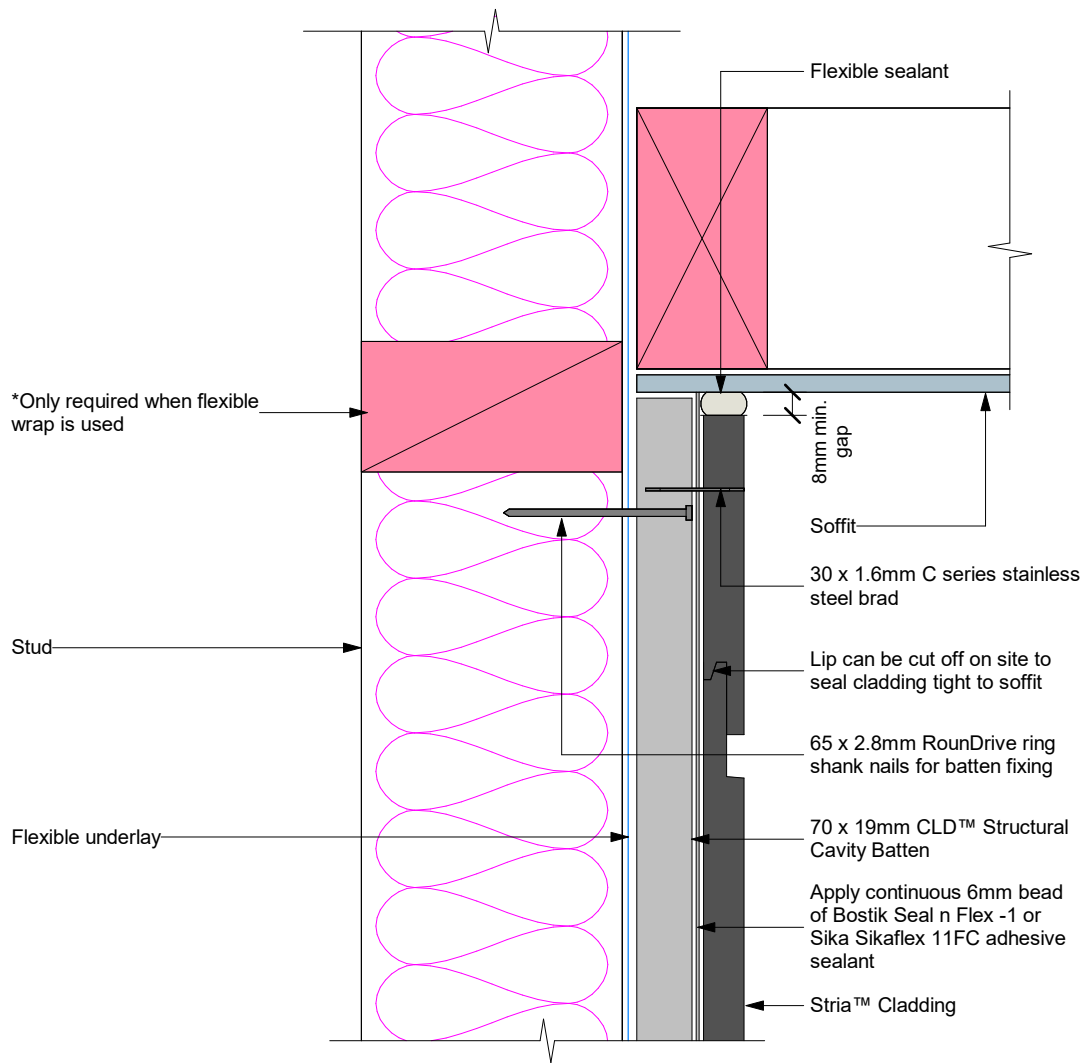

Note: Site cut edges to be primed

Figure 14: Soffit detail top ventilation

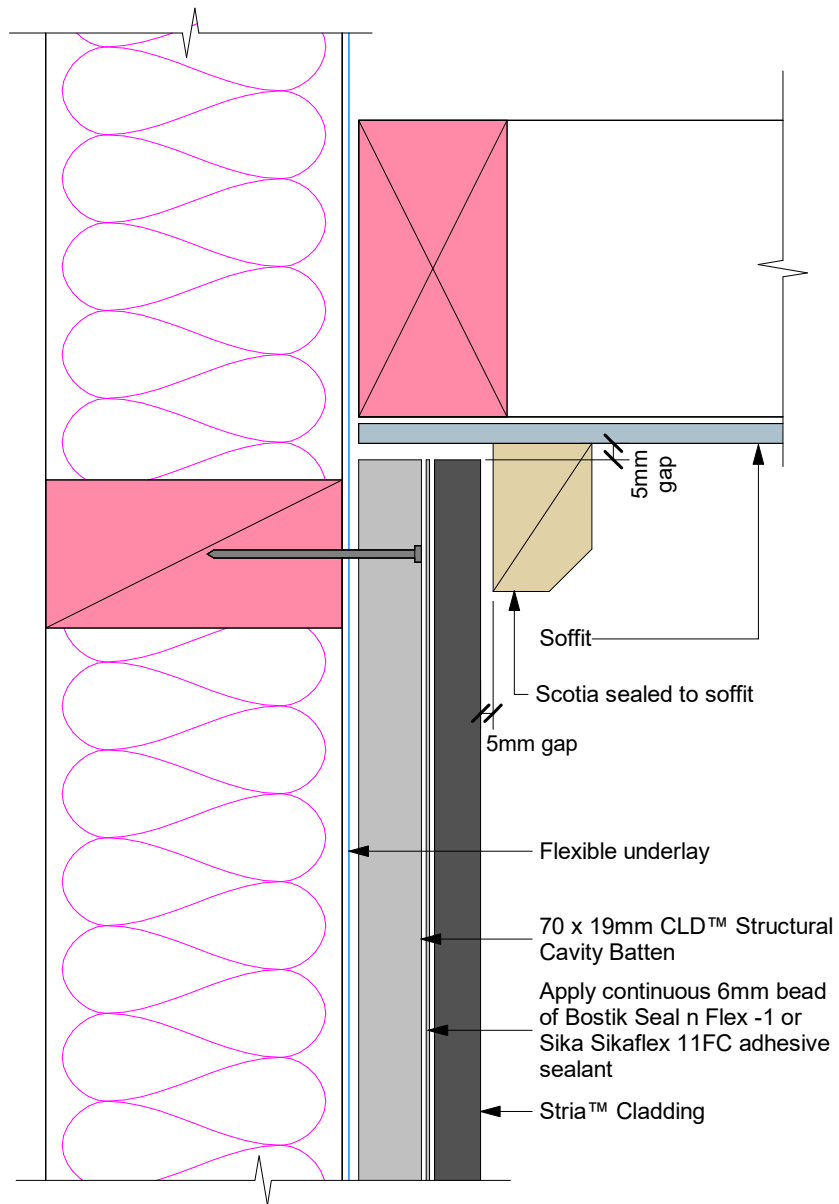

Figure 15: Nil soffit detail top ventilation

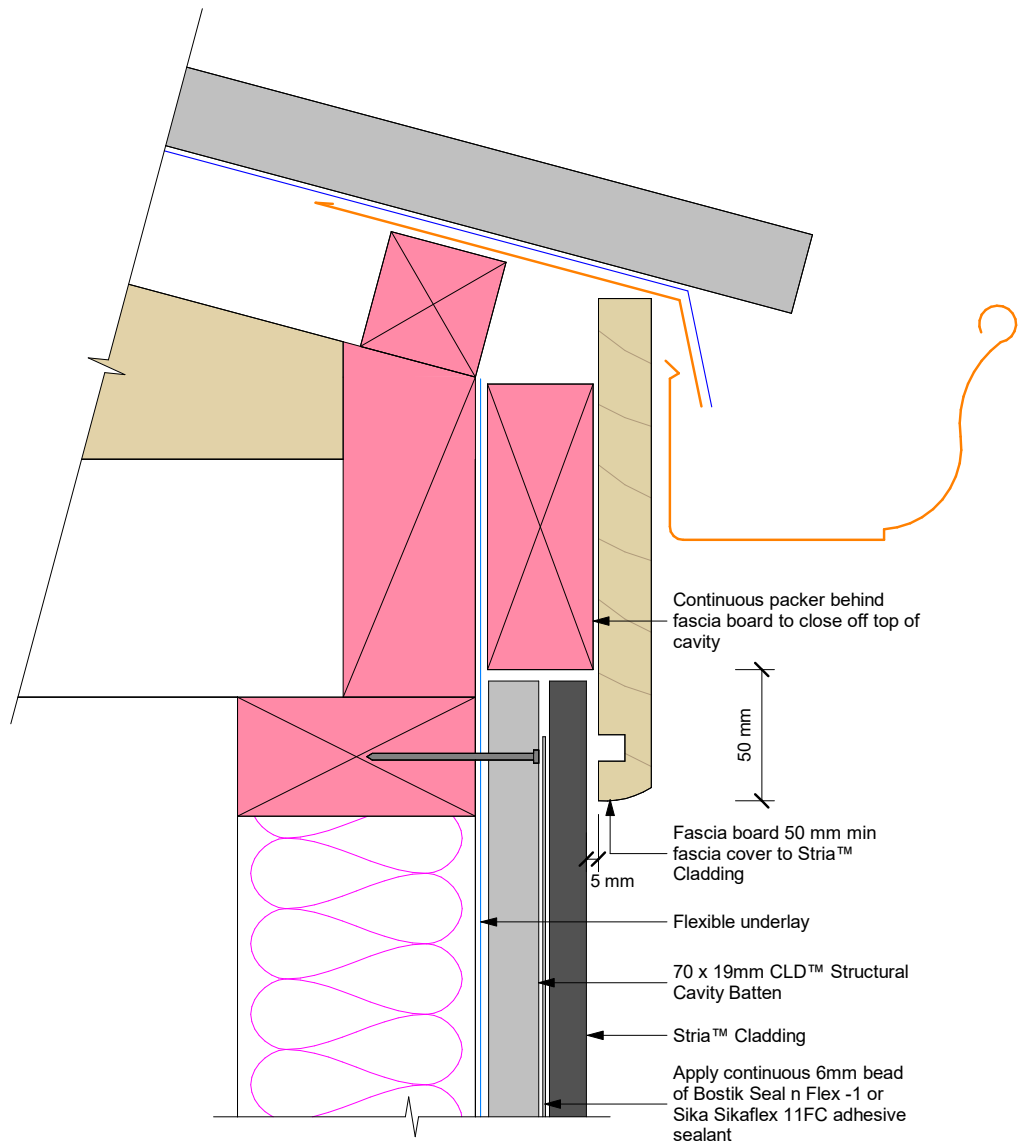

Figure 16: Window sill

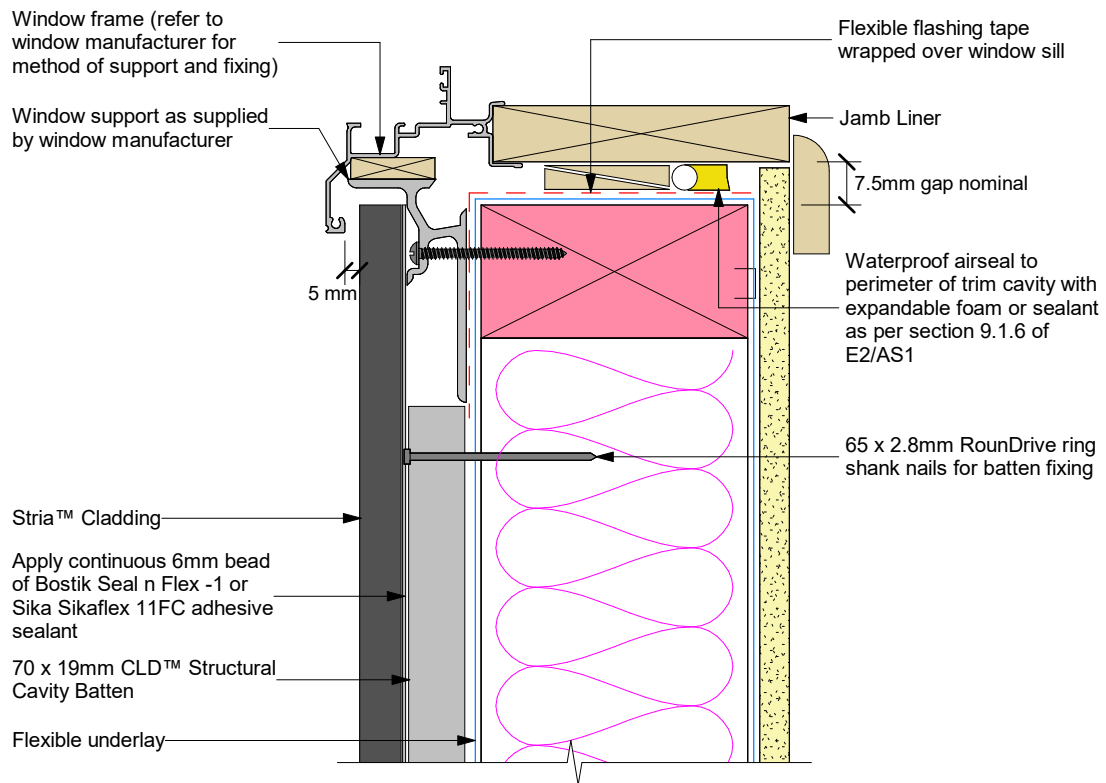

Figure 17: Window jamb

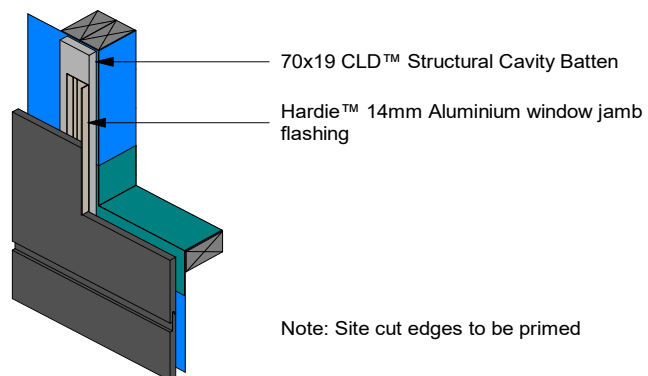
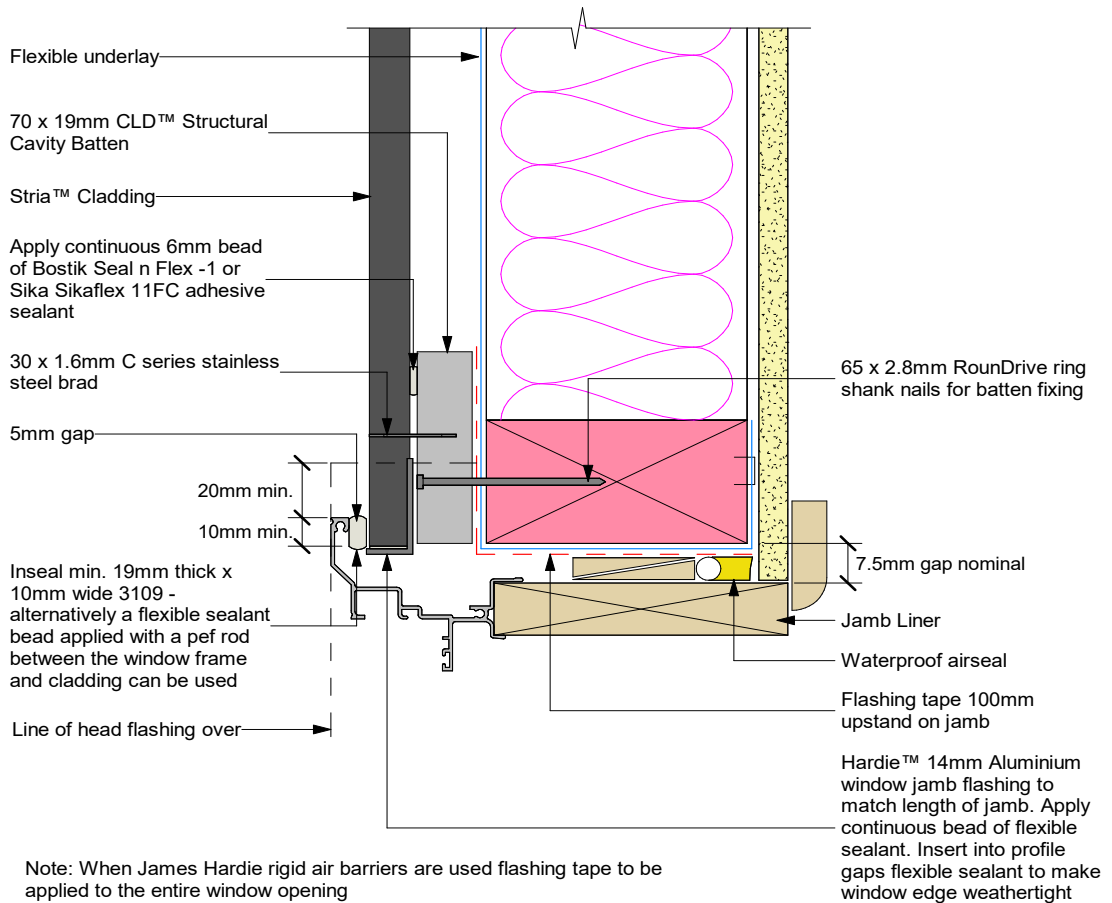

Figure 18: Window head with full cladding across head flashing

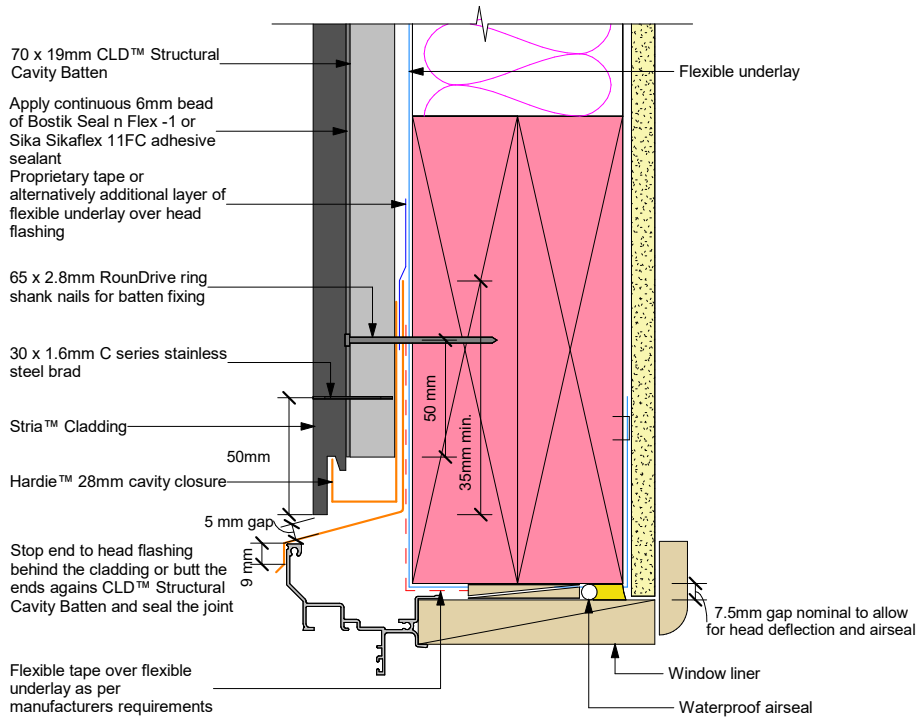
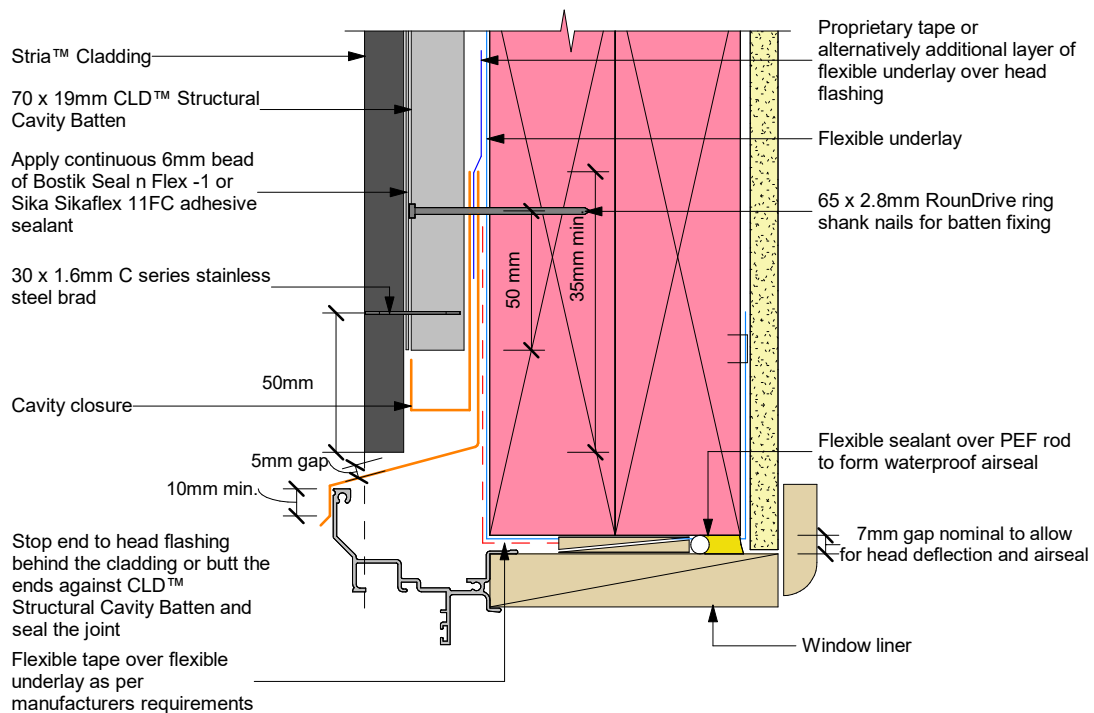

Figure 19: Window head with cladding cut around head flashing



Note: Site cut edges to be primed

Figure 20: Window head stop end

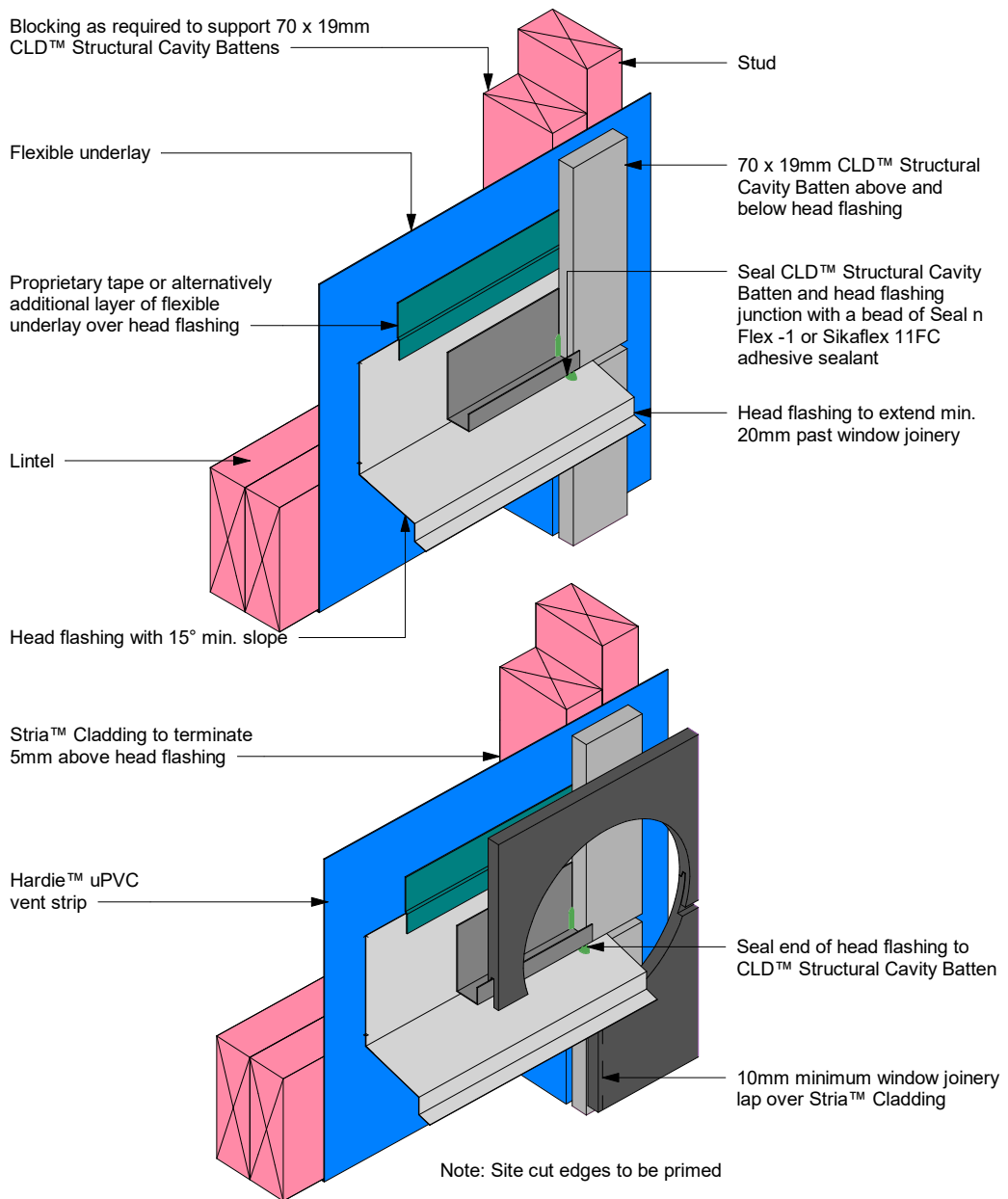
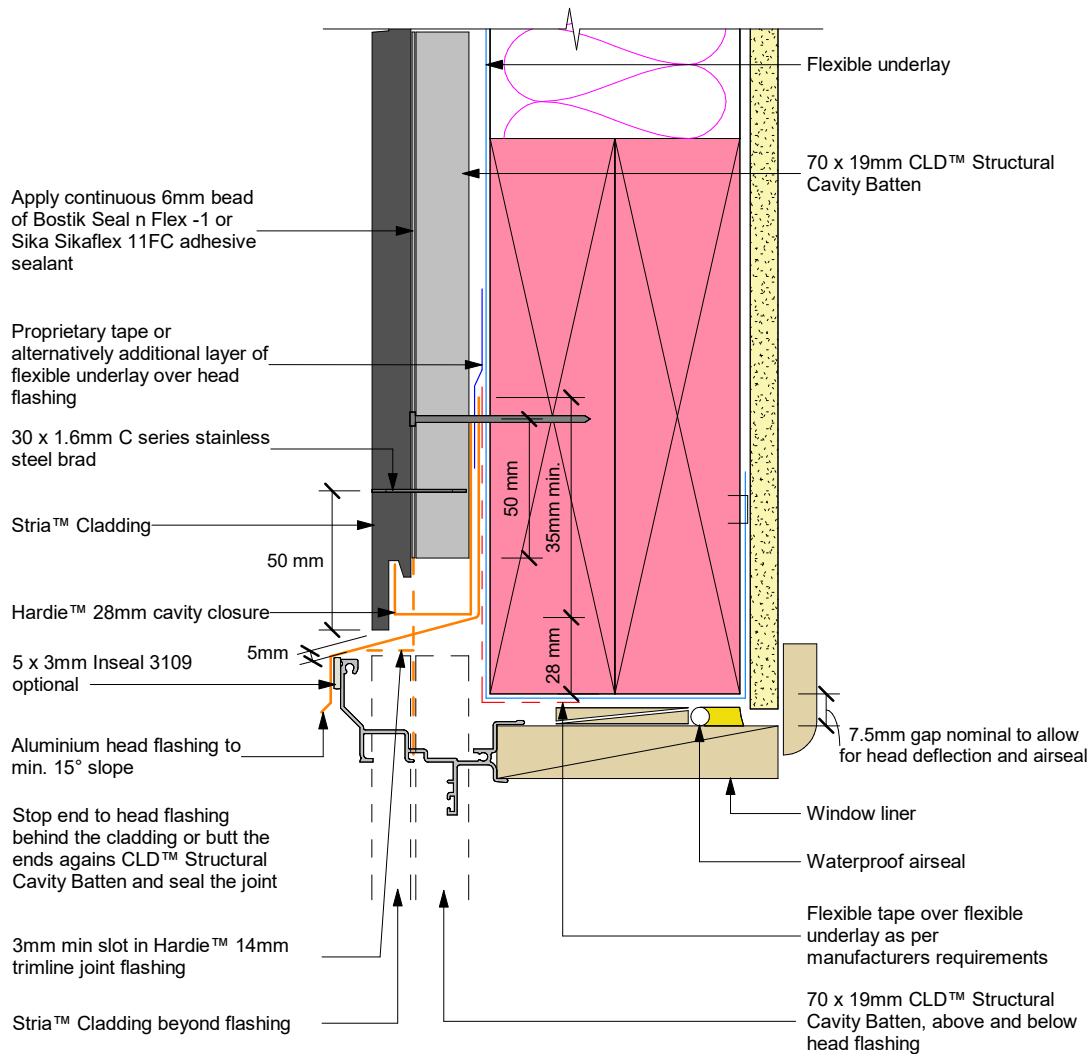

Figure 21: Trimline joint detail at window head



Note:

- When James Hardie rigid air barrier is used flashing tape to be applied to the entire window opening
- Sealant must be installed between head flashing and window flange VH and EH wind zones and SED pressures
- Alternatively, the head flashings can be formed with stop ends as per E2/AS1

Figure 22: Trimline joint at window head

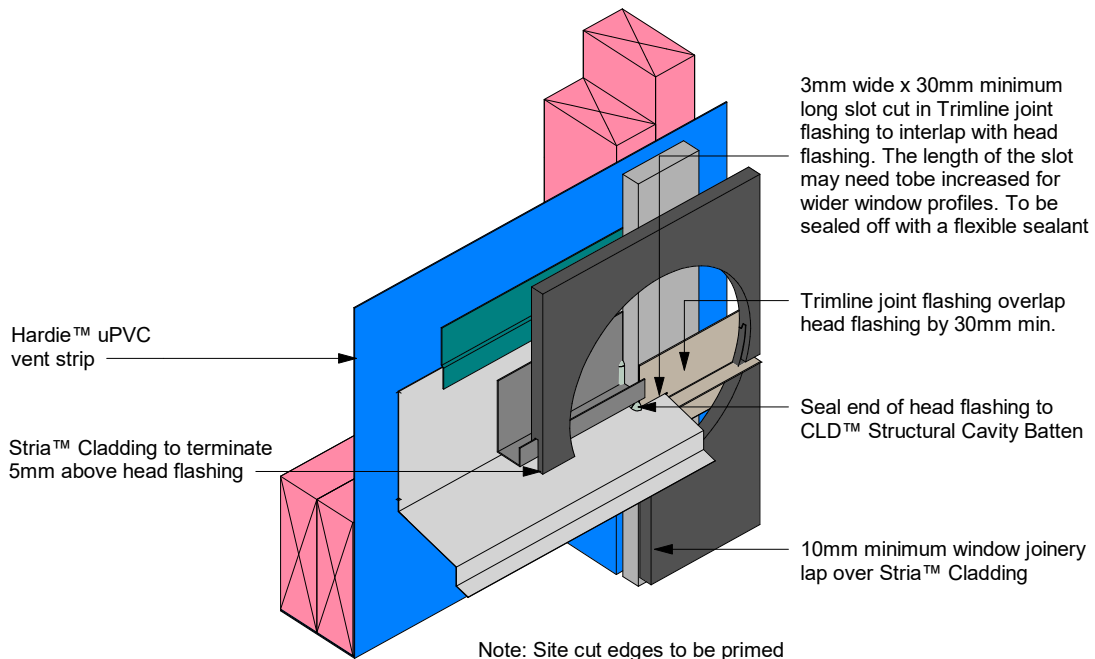
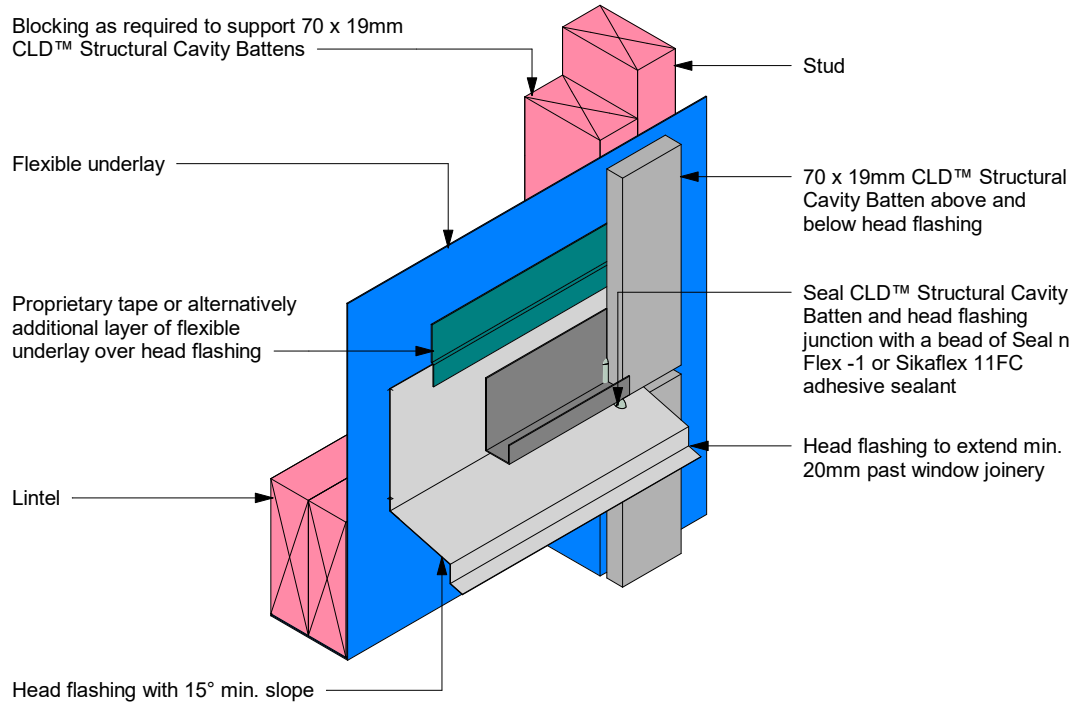
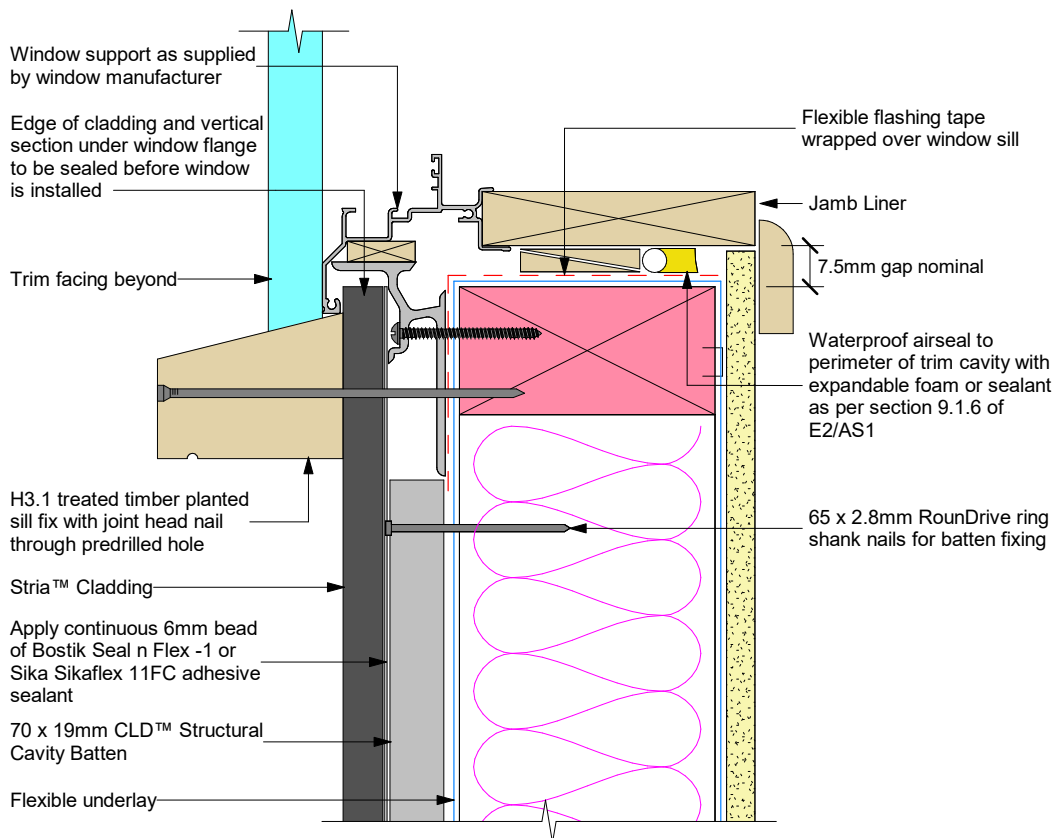

Figure 23: Window sill with facing



General notes for materials selection

1. Flashing materials must be selected based on environmental exposure, refer to NZS 3604 and Table 20 of NZBC E2/AS1
2. Flexible underlay must comply with acceptable solution E2/AS1
3. Flashing tape must have proven compatibility with the selected flexible underlay and other materials with which it comes into contact
4. When HomeRAB™ Pre-Cladding or RAB™ Board are used flashing tape to be applied to the entire opening

Refer to the manufacturer or supplier for technical information for these materials

Figure 24: Window jamb with facing

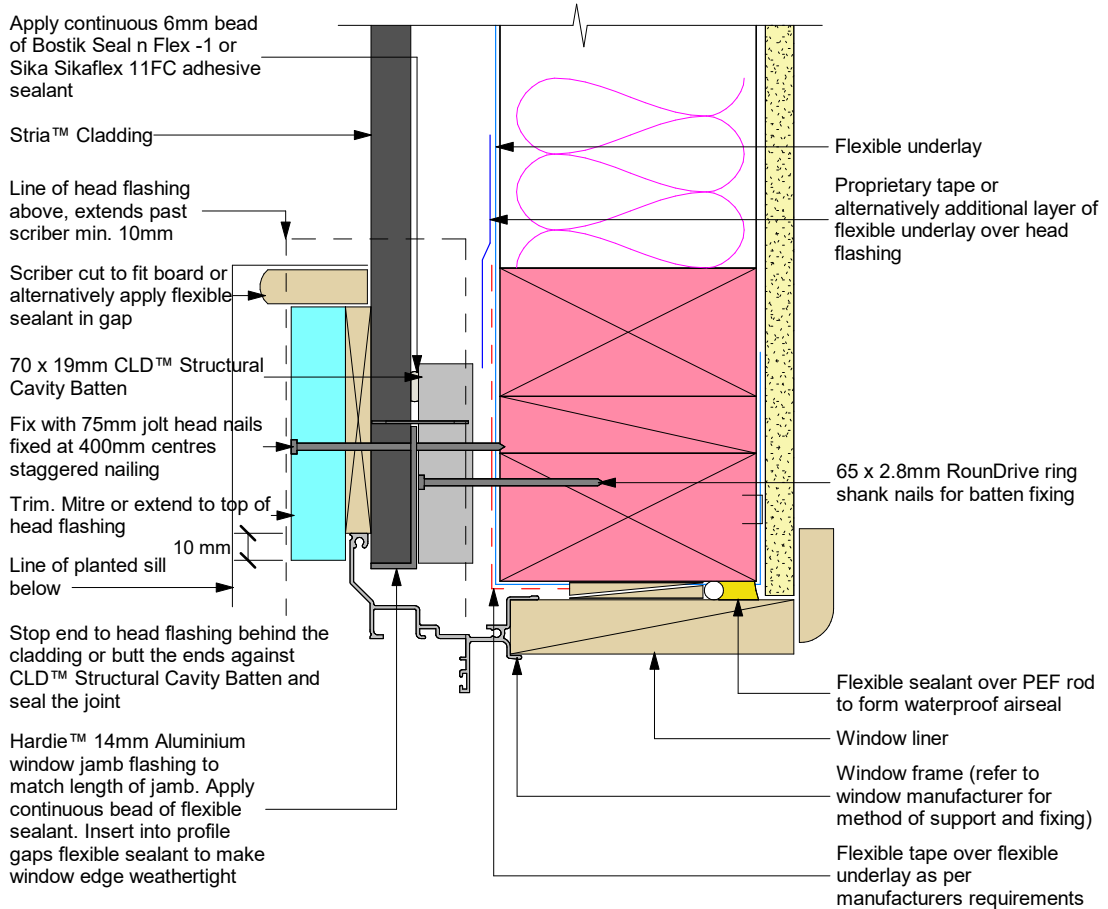

Note:

- When James Hardie rigid air barrier is used flashing tape to be applied to the entire window opening
- Site cut edges to be primed

Figure 25: Window head with facings

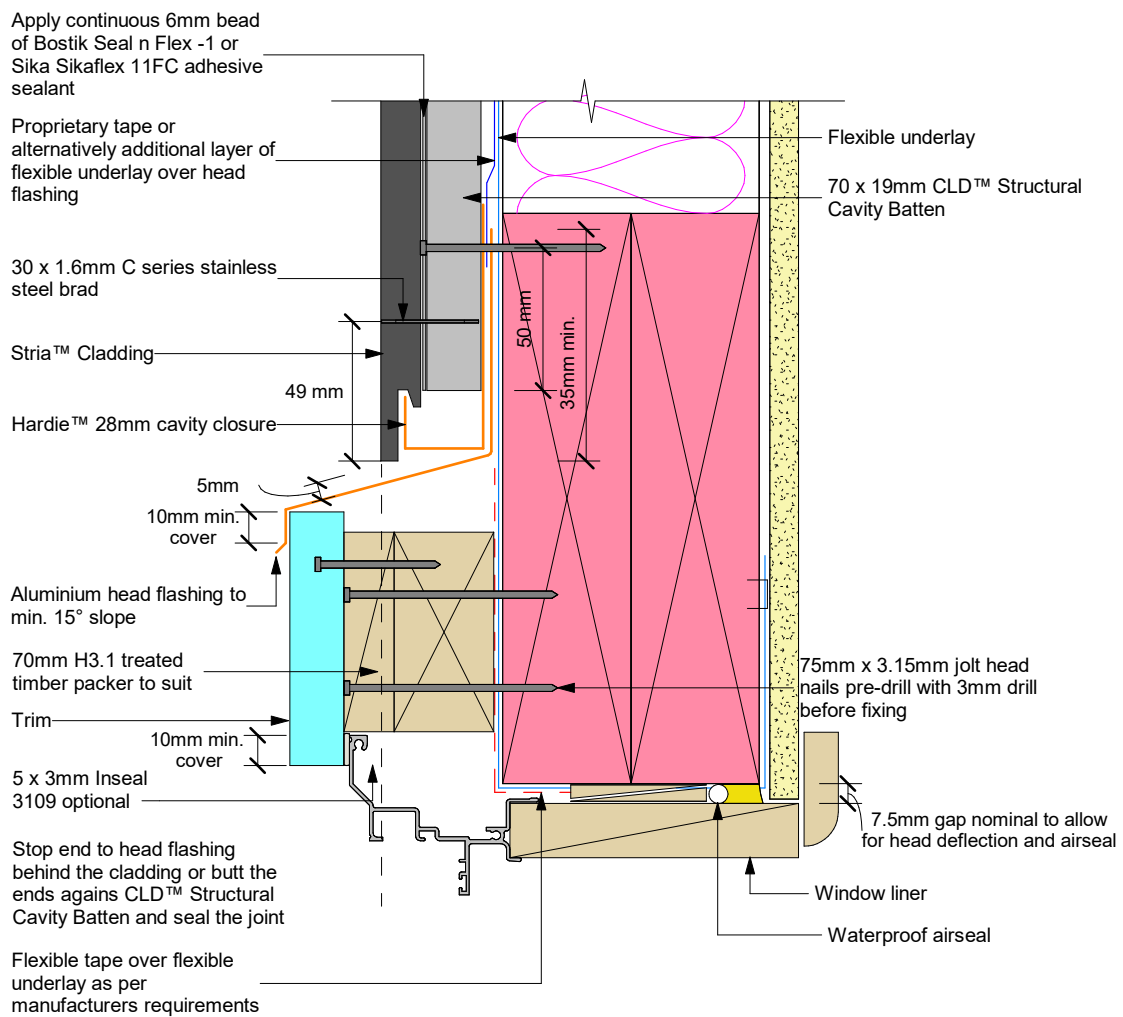

Note:

- When HomeRAB™ Pre-Cladding or RAB™ Board is used flashing tape to be applied to the entire window opening
- Sealant must be installed between head flashing and window flange VH and EH wind zones and SED pressures
- Alternatively, the head flashings can be formed with stop ends as per E2/AS1

Figure 26: Door sill support detail

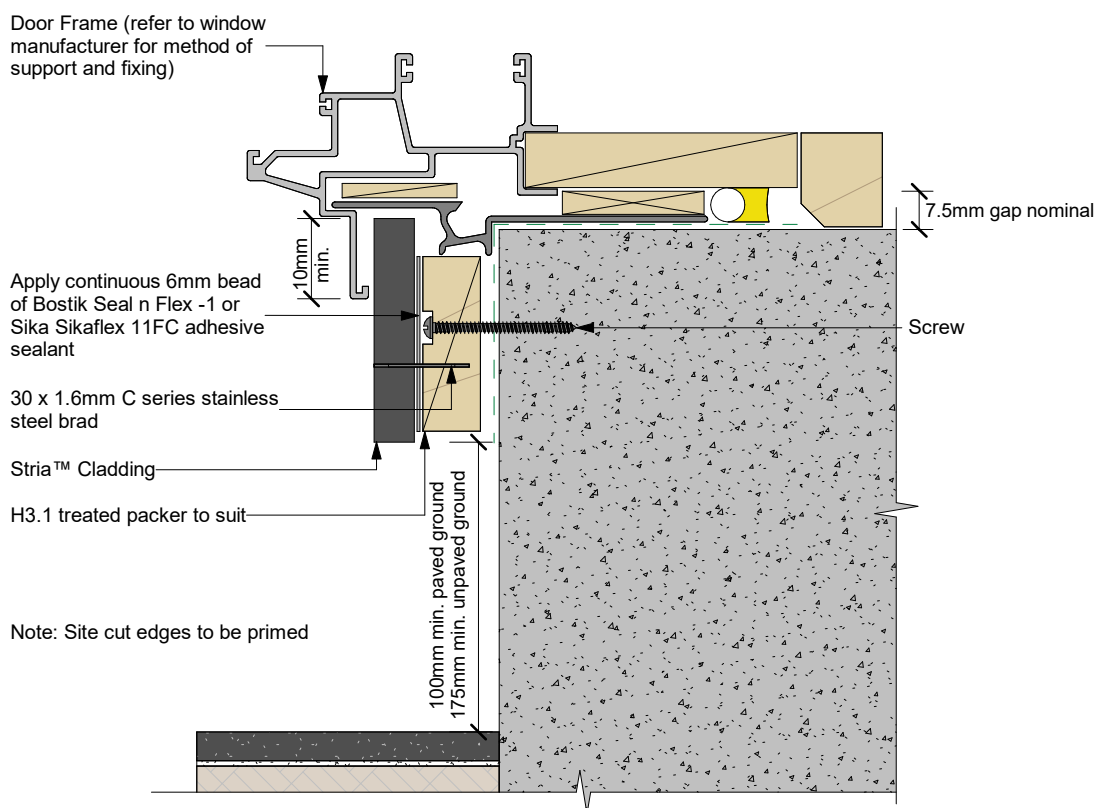

Refer to the manufacturer or supplier for technical information for these materials

General notes for materials selection

1. Flashing materials must be selected based on environmental exposure, refer to NZS 3604 and Table 20 of the NZBC E2/AS1
2. Flexible underlay must comply with acceptable solution E2/AS1
3. Flashing tape must have proven compatibility with the selected flexible underlay and other materials with which it comes into contact
4. When HomerAB™ Pre-Cladding or RAB™ Board are used flashing tape to be applied to the entire opening

Figure 27: Continuous cladding over joist at floor level

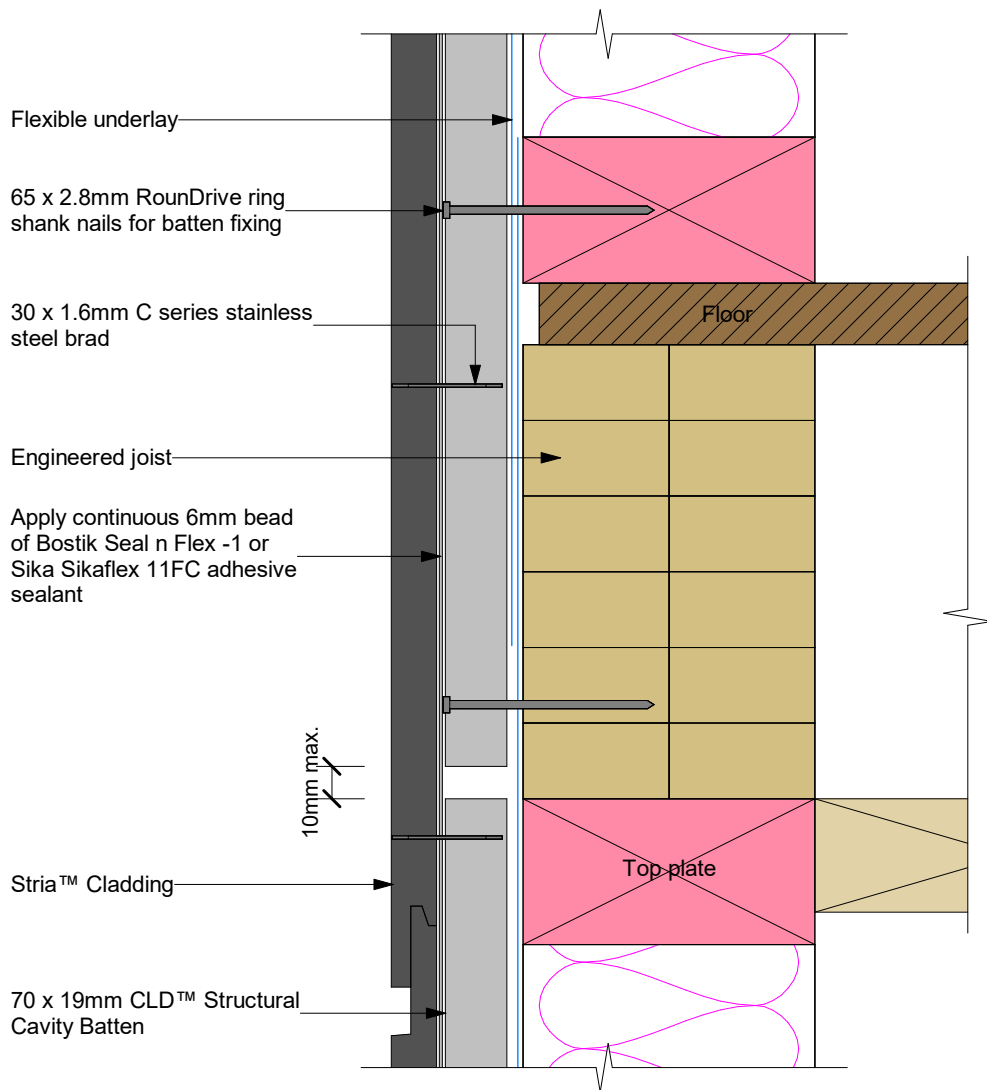
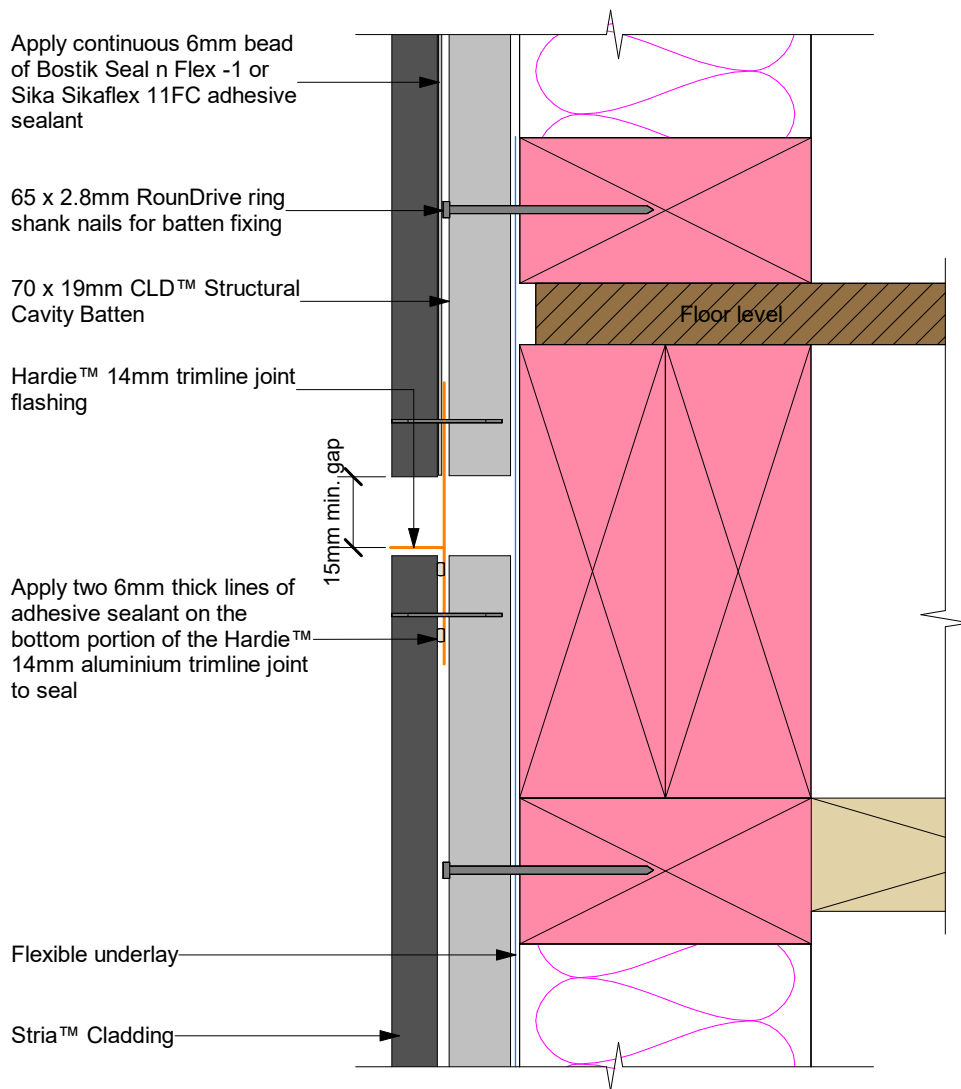

Figure 28: Trimline joint flashing at floor level



Notes:

- Take care to ensure continuous seal is formed between panel and the trimline joint
- Trimline horizontal Jointer will be required over the butt joint of the Hardie™ 14mm aluminium trimline joint
- Site cut edges to be primed
- Check architects plans for the type of flashing to be used
- Check fixing centres and edge distances
- When 50 year durability is required refer Table 20 E2/AS1
- The flashing to be placed in the centre of the floor joists. Do not fix cavity battens or cladding into floor joists

Figure 29: Trimline joint flashing at external corner

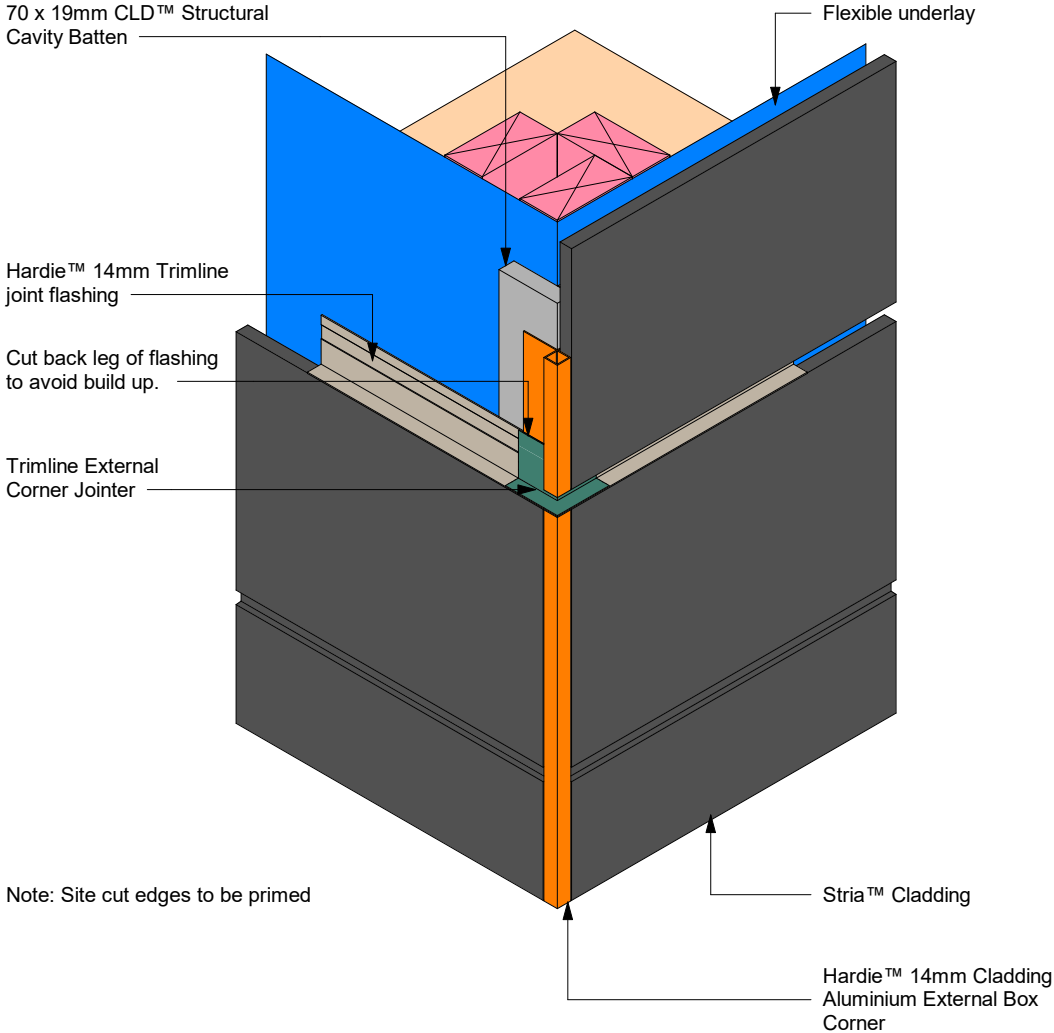

Figure 30: Trimline joint flashing at internal corner

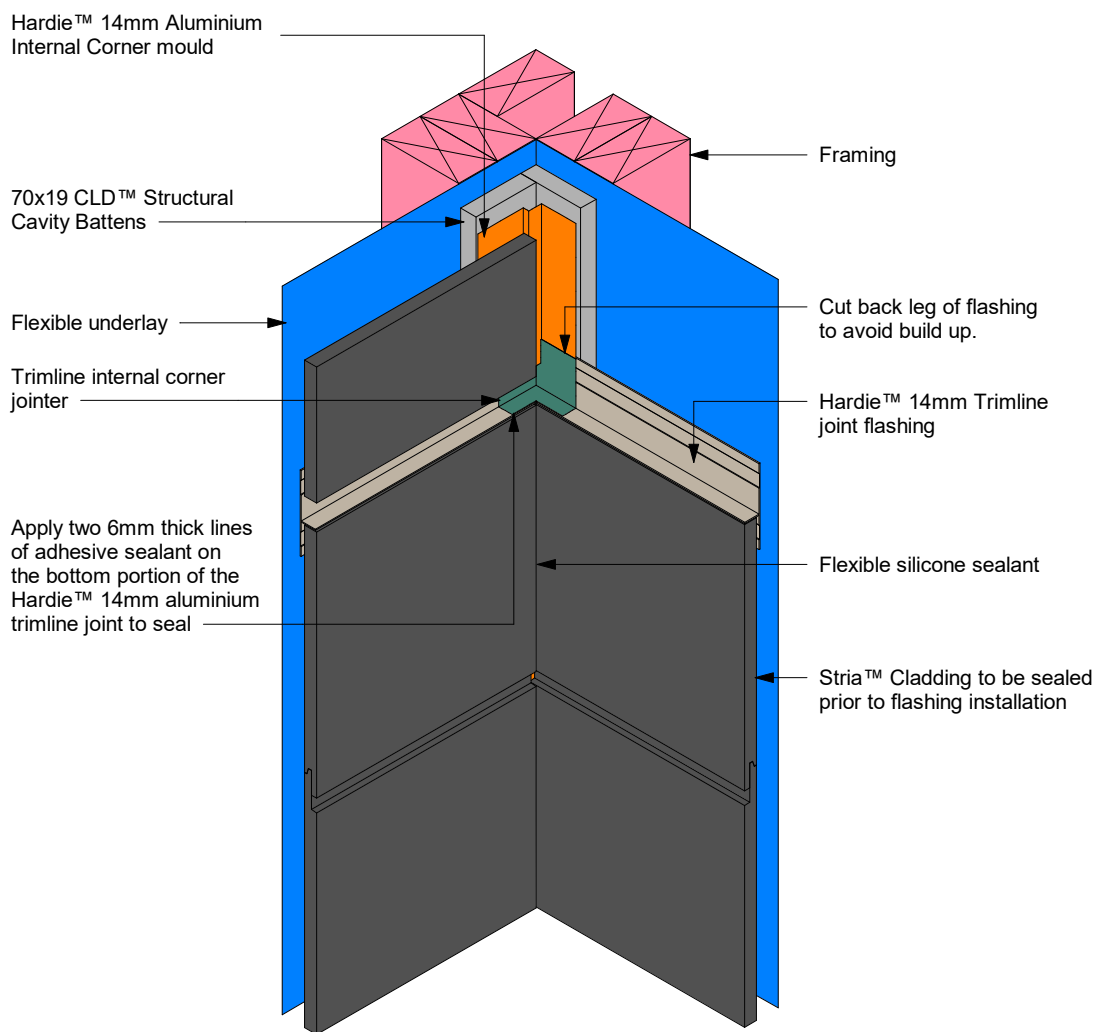
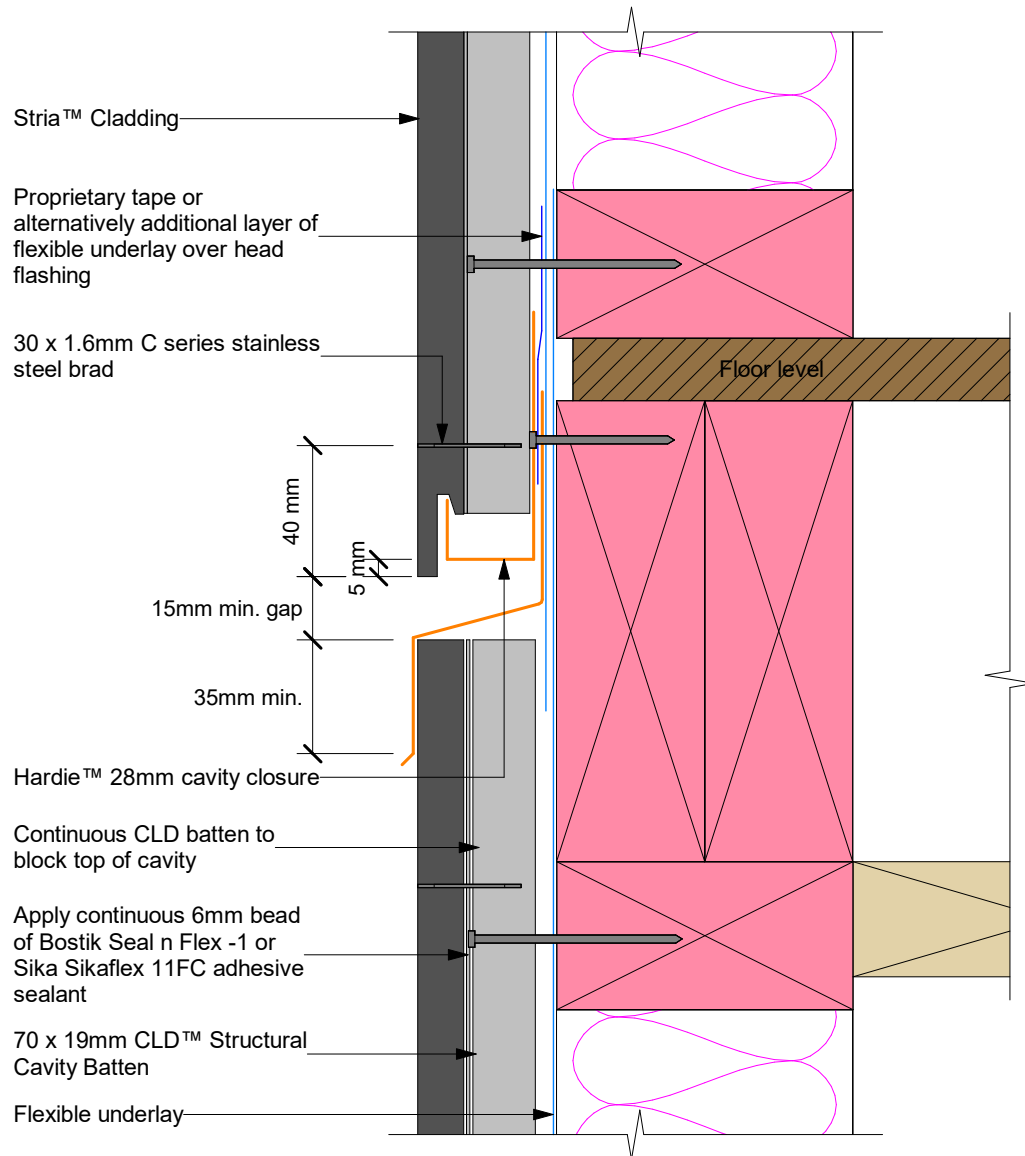

Figure 31: Drained flashing joint at floor level



Notes:

- Check architect's plans for the type of flashing to be used
- Check fixing centres and edge distances
- If top fixings are to be hidden by the Z flashing they will need to be fixed and sealed before the flashing is installed
- Cut edges need to be primed
- When 50 year durability is required refer Table 20 E2/AS1
- The flashing to be placed in the centre of the floor joists. Do not fix CLD™ Structural Cavity Battens or cladding into floor joists

Figure 32: Drained flashing at external corner

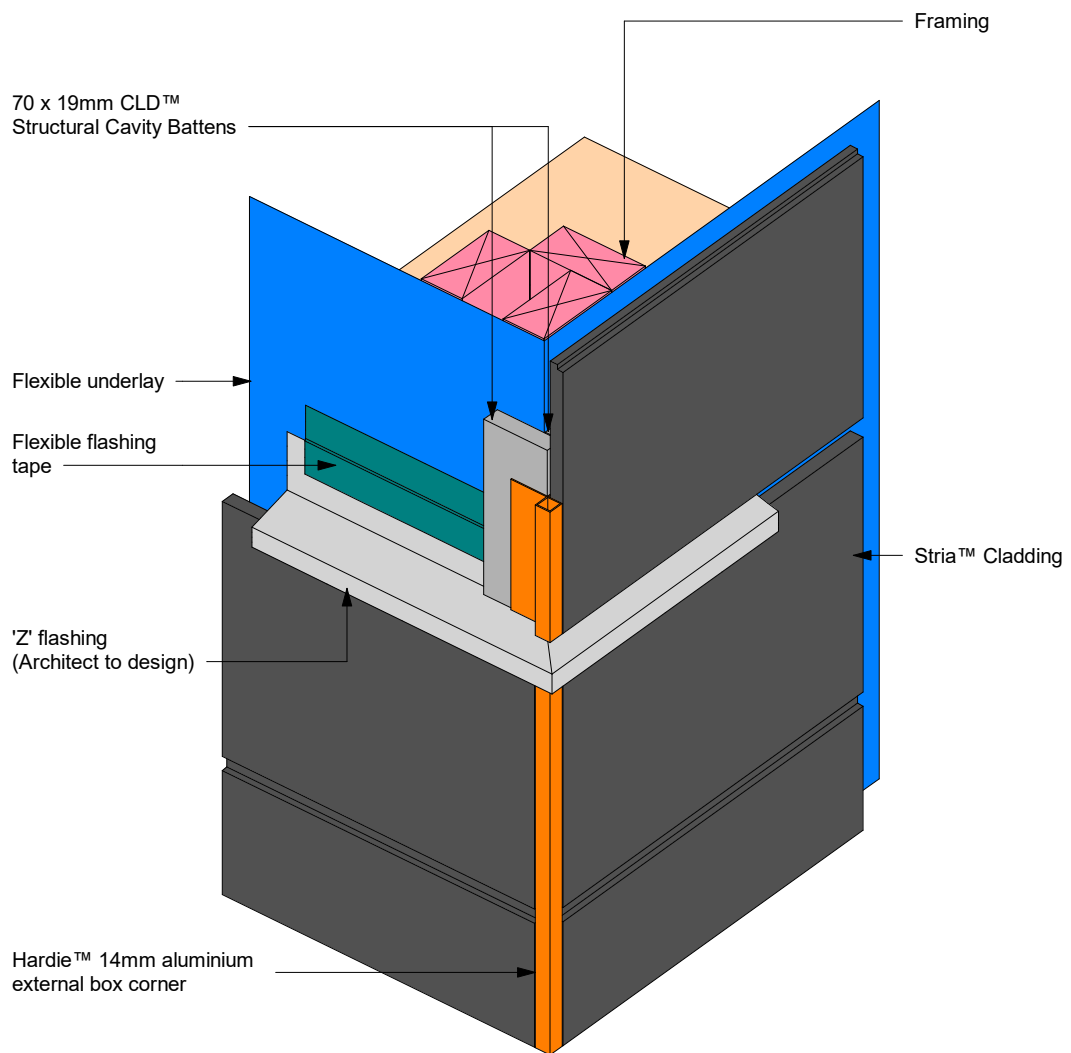

Note: Site cut edges to be primed

Figure 33: Pipe penetration

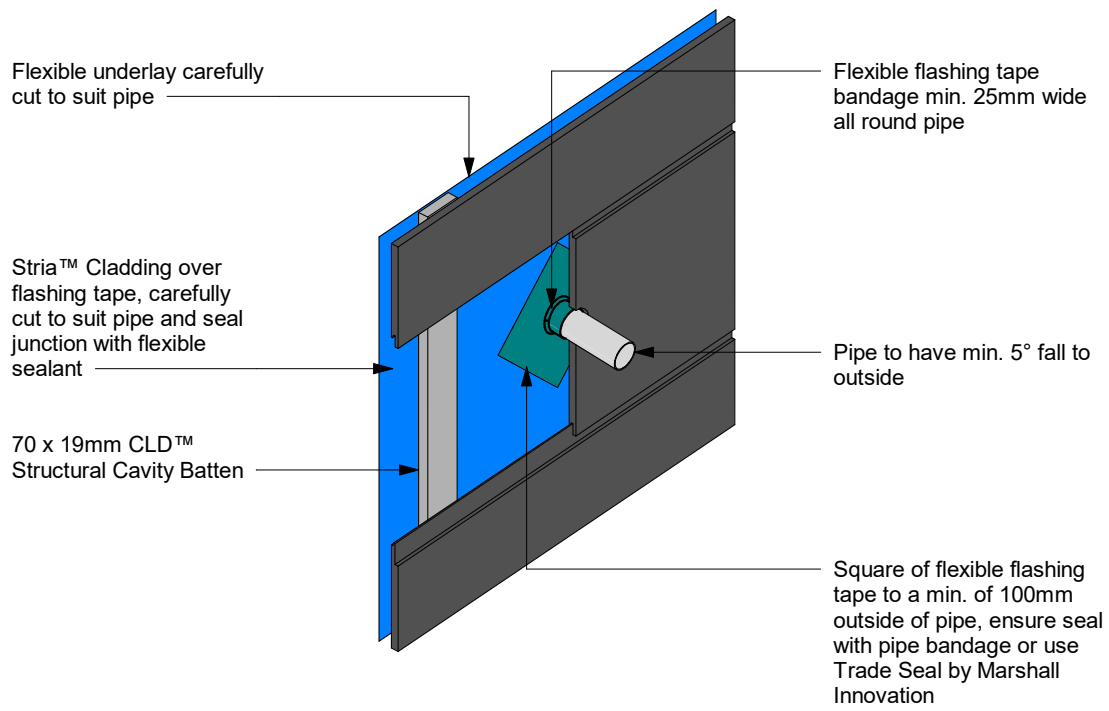

Note: Site cut edges to be primed

Figure 34: Apron flashing detail

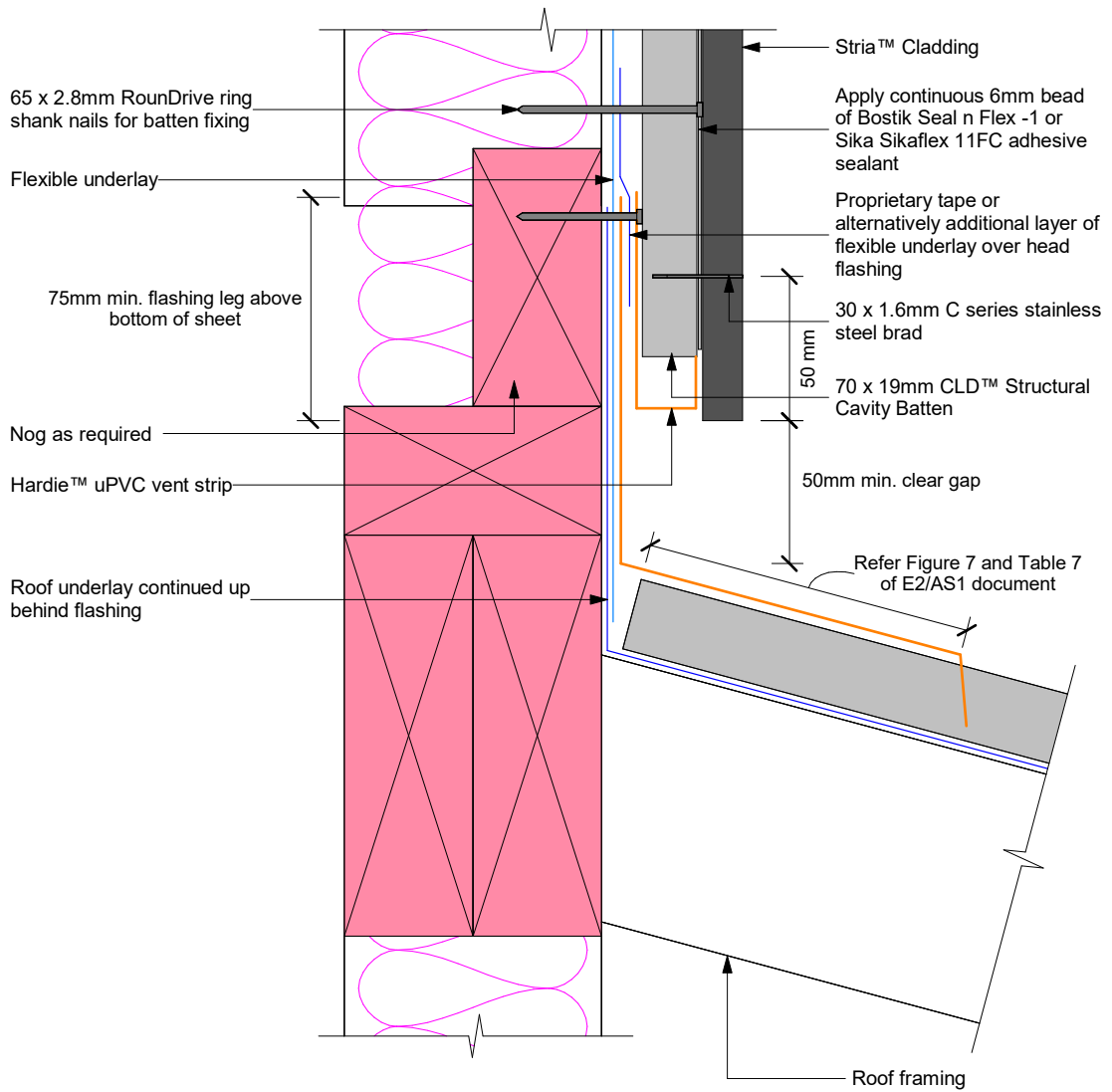

Notes:

- When 50 year durability for flashing is required refer to Table 20 NZBC E2/AS1 document
- Site cut edges to be primed

Figure 35: Parapet flashing

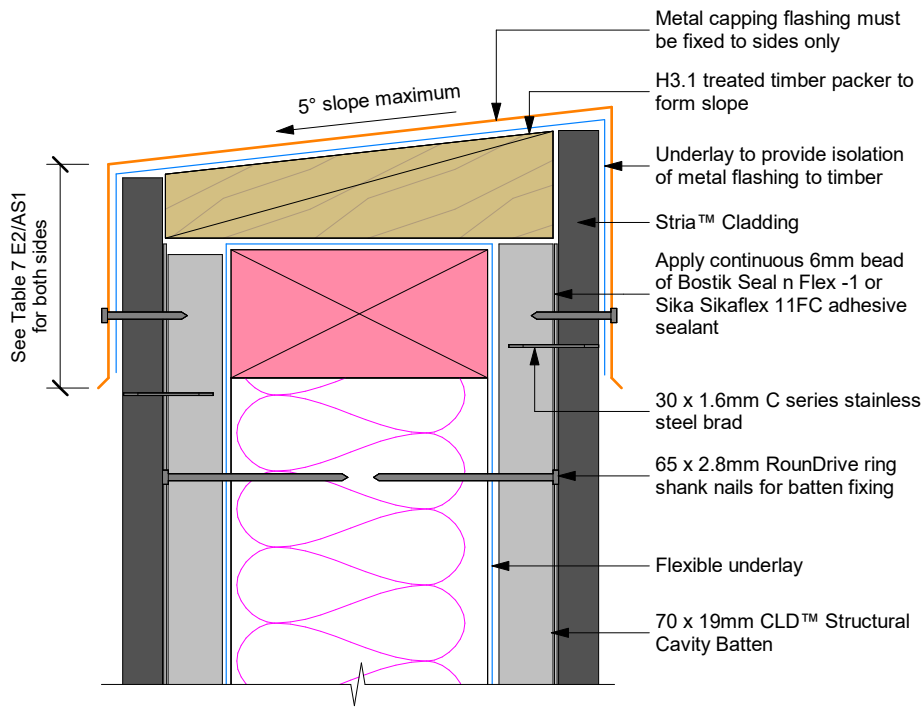

Figure 36: Roof to wall junction detail

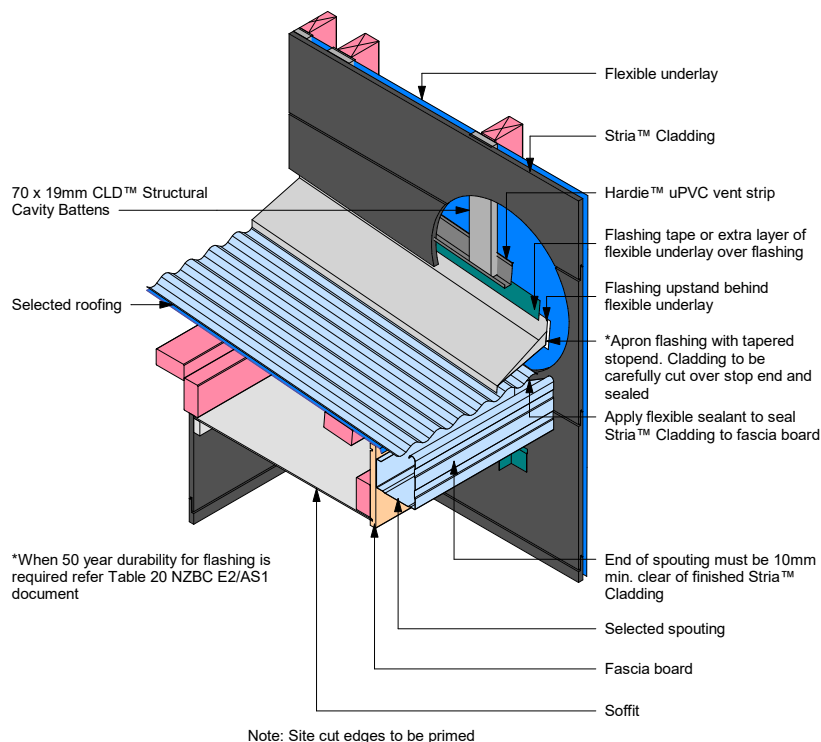
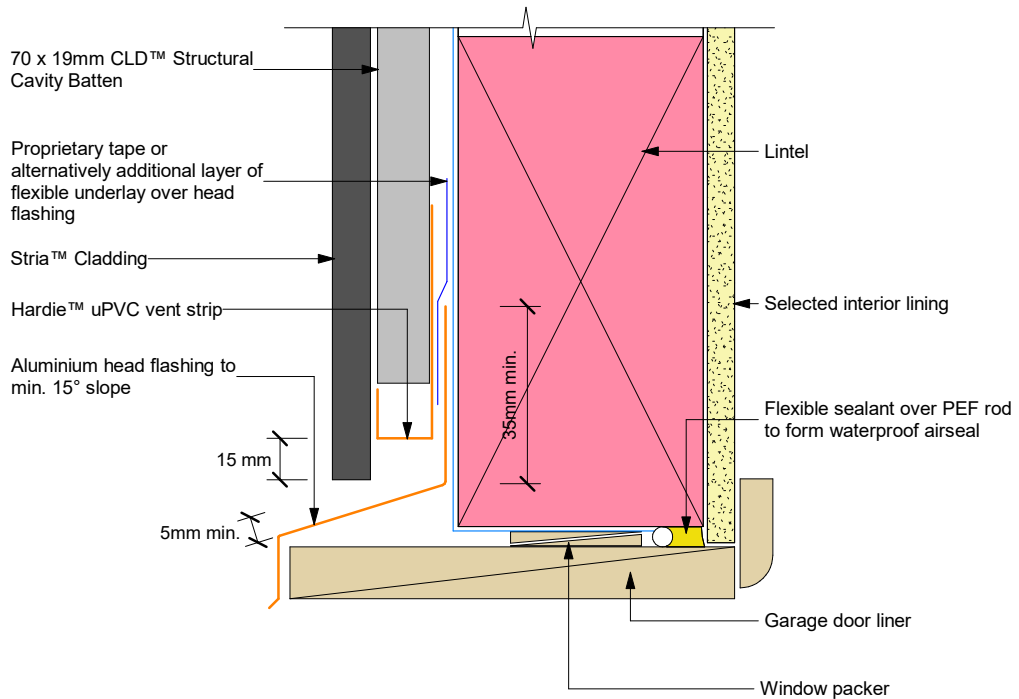
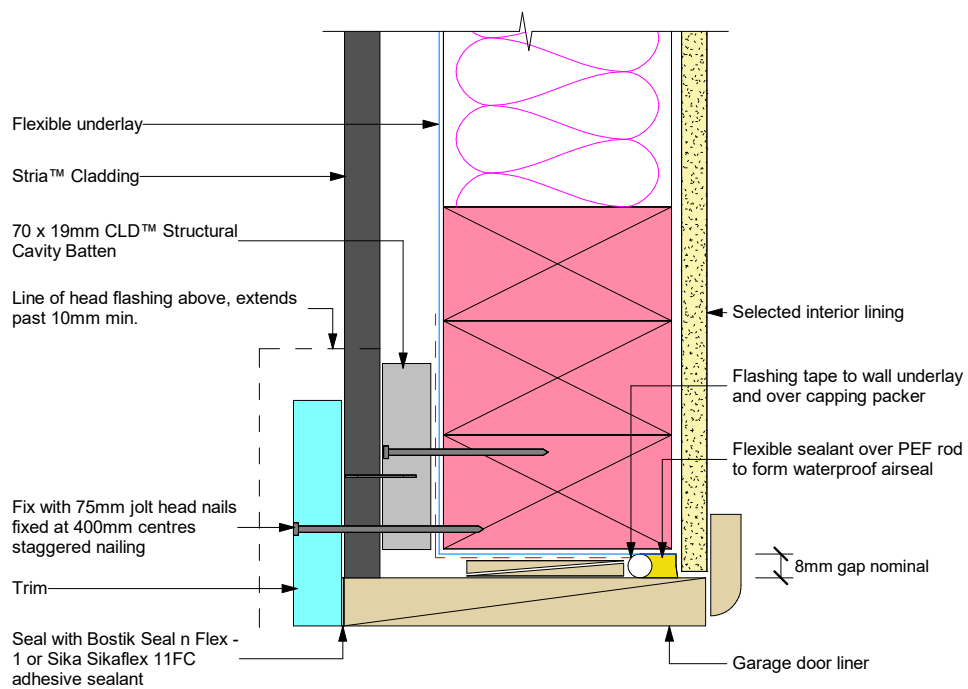

Figure 37: Garage head



- Sealant must be applied between head flashing and trim in VH and EH wind zones and SED wind pressures
- Site cut edges to be primed

Figure 38: Garage jamb



Note: Site cut edges to be primed

Figure 39: Cavity batten setout building height over 10m

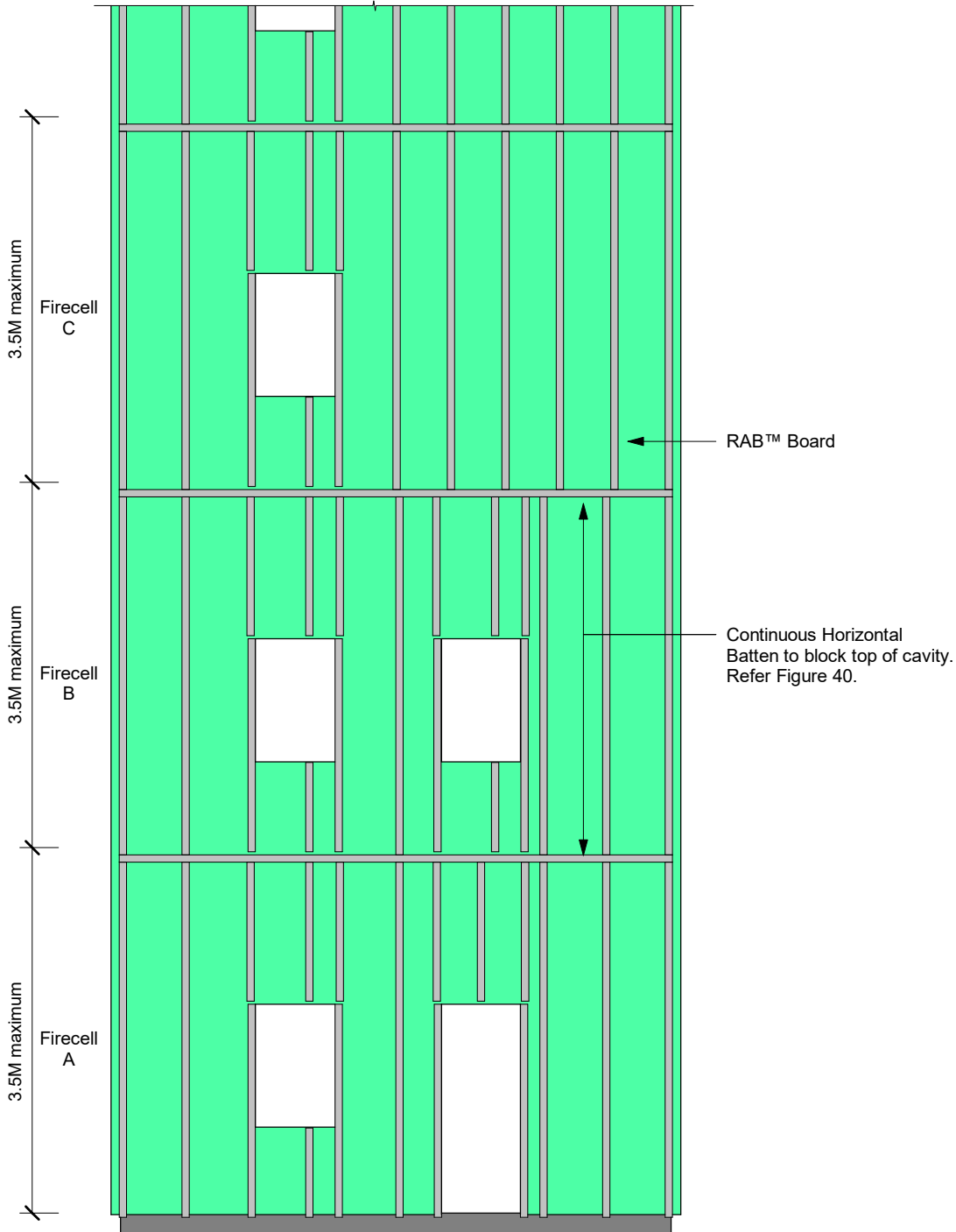
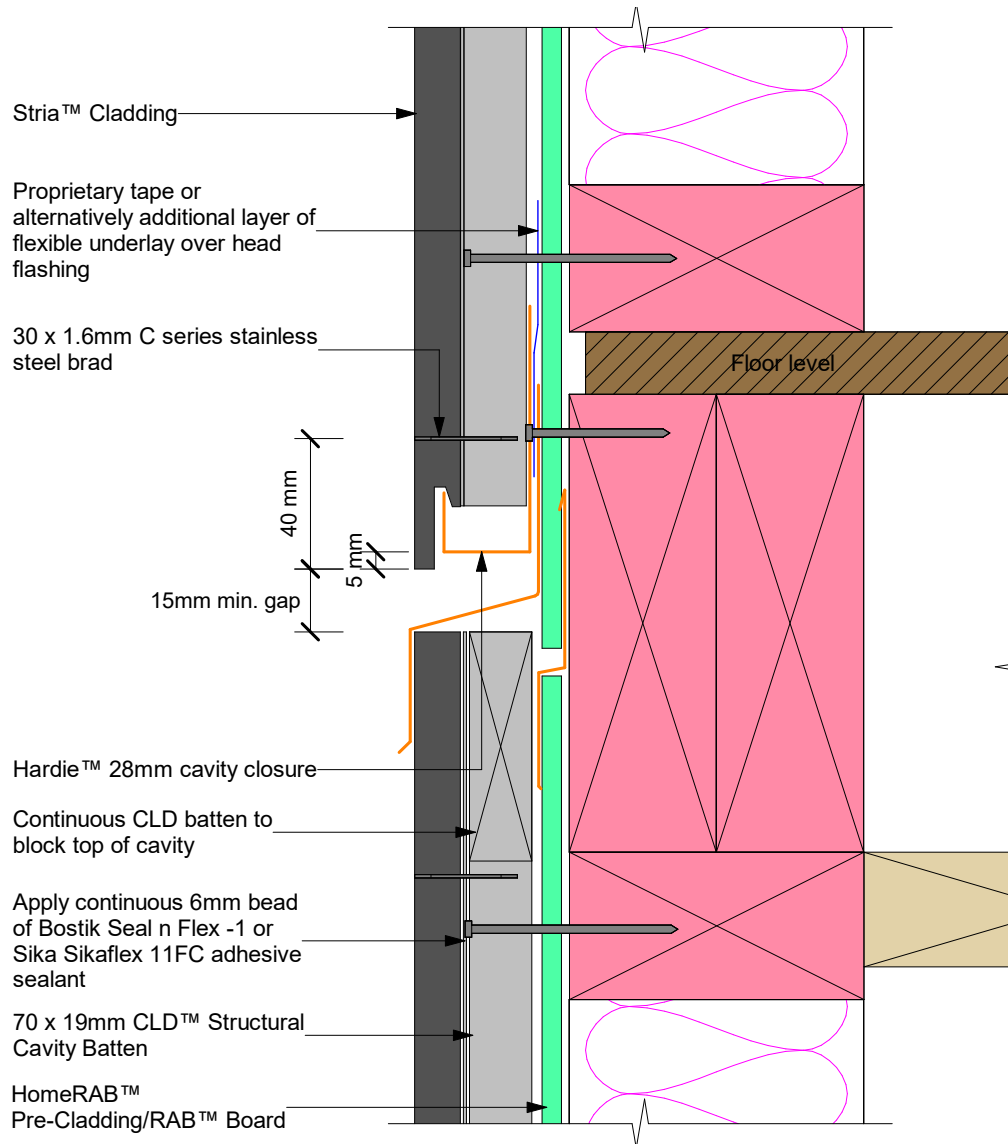

Figure 40: Inter-tenancy fire separation



For all meter box details please visit our website at www.jameshardie.co.nz or Ask James Hardie on **0800 808 868**.

Product Warranty

James Hardie New Zealand Limited (“James Hardie”) warrants for a period of 25 years from the date of purchase that the Stria™ Cladding and Hardie™ CLD™ Structural Cavity Batten (the “Product”), will be free from defects due to defective factory workmanship or materials and, subject to compliance with the conditions below, will be resistant to cracking, rotting, fire and damage from termite attacks to the extent set out in James Hardie’s relevant published literature current at the time of installation. James Hardie warrants for a period of 15 years from the date of purchase that the accessories supplied by James Hardie will be free from defects due to defective factory workmanship or materials.

Nothing in this document shall exclude or modify any legal rights a customer may have under the Consumer Guarantees Act or otherwise which cannot be excluded or modified at law.

CONDITIONS OF WARRANTY:

The warranty is strictly subject to the following conditions:

- a) James Hardie will not be liable for breach of warranty unless the claimant provides proof of purchase and makes a written claim either within 30 days after the defect would have become reasonably apparent or, if the defect was reasonably apparent prior to installation, then the claim must be made prior to installation;
- b) this warranty is not transferable;
- c) the Product must be installed and maintained strictly in accordance with the relevant James Hardie literature current at the time of installation and must be installed in conjunction with the components or products specified in the literature. Further, all other products, including coating and jointing systems, applied to or used in conjunction with the Product must be applied or installed and maintained strictly in accordance with the relevant manufacturer’s instructions and good trade practice;
- d) the project must be designed and constructed in strict compliance with all relevant provisions of the current New Zealand Building Code (“NZBC”), regulations and standards;
- e) the claimant’s sole remedy for breach of warranty is (at James Hardie’s option) that James Hardie will either supply replacement product, rectify the affected product or pay for the cost of the replacement or rectification of the affected product;
- f) James Hardie will not be liable for any losses or damages (whether direct or indirect) including property damage or personal injury, consequential loss, economic loss or loss of profits, arising in contract or negligence or howsoever arising. Without limiting the foregoing James Hardie will not be liable for any claims, damages or defects arising from or in any way attributable to poor workmanship, poor design or detailing, settlement or structural movement and/or movement of materials to which the Product is attached, incorrect design of the structure, acts of God including but not limited to earthquakes, cyclones, floods or other severe weather conditions or unusual climatic conditions, efflorescence or performance of paint/coatings applied to the Product, normal wear and tear, growth of mould, mildew, fungi, bacteria, or any organism on any Product surface or Product (whether on the exposed or unexposed surfaces);
- g) all warranties, conditions, liabilities and obligations other than those specified in this warranty are excluded to the fullest extent allowed by law;
- h) if meeting a claim under this warranty involves re-coating of Products, there may be slight colour differences between the original and replacement Products due to the effects of weathering and variations in materials over time.

Disclaimer: The recommendations in James Hardie’s literature are based on good building practice, but are not an exhaustive statement of all relevant information and are subject to conditions (c), (d), (f) and (g) above. James Hardie has tested the performance of the Stria™ Cladding and Hardie™ CLD™ Structural Cavity Batten when installed in accordance with the Stria™ Cladding and Hardie™ CLD™ Structural Cavity Batten technical specification, in accordance with the standards and verification methods required by the NZBC and those test results demonstrate the product complies with the performance criteria established by the NZBC. However, as the successful performance of the relevant system depends on numerous factors outside the control of James Hardie (e.g. quality of workmanship and design) James Hardie shall not be liable for the recommendations made in its literature and the performance of the relevant system, including its suitability for any purpose or ability to satisfy the relevant provisions of the NZBC, regulations and standards, as it is the responsibility of the building designer to ensure that the details and recommendations provided in the relevant James Hardie installation manual are suitable for the intended project and that specific design is conducted where appropriate.

© 2022. James Hardie New Zealand Limited. TM and ® denotes a Trademark or Registered Mark owned by James Hardie Technology Limited.

