



Hume Pine (NZ) Ltd
Pineclad & Pinetrim XT
Horizontal Weatherboard
External Cladding Systems

Pineclad Pinetrim^{XT}

Design & Installation Guide

General Information	2
Description	3
Pineclad & Pinetrim XT Horizontal Weatherboard Profiles	4
Optional Exterior Pineclad & Pinetrim XT Horizontal Weatherboard Profiles	4
Information For Designers	6
Skills Required	6
Considerations When Designing	6
Information For Installers	7
Skills Required	7
Handling	7
Storage	7
Health & Safety	7
Tools Required	7
Installation Requirements	8
Framing & Flexible Underlay or Rigid Air Barrier	8
Fixings	8
Fixing of Structural Battens	9
Aluminium Joinery	9
Weatherboards	9
Ground Clearances	10
Finishing	10
Typical Details	10



General Information

This document is for designers and installers to use to help in the specification and installation of the Pineclad and Pinetrim XT Horizontal Weatherboard External Cladding systems (the systems).

Pineclad

- Is manufactured in New Zealand from locally sourced FSC certified Radiata Pine
- Is treated to hazard class H3.1 with a light organic solvent preservative (LOSP)
- Components are supplied, painted with an oil-based primer.

Pinetrim XT

- Is manufactured in China from FSC certified Radiata Pine sourced from a number of sources including New Zealand
- Is treated to hazard class H3.1 with LOSP
- Components are supplied pre-sanded and painted with a three-coat acrylic primer and undercoat system.

This document must be read in conjunction with

- Hume Pine *Pineclad and Pinetrim XT Horizontal Weatherboard External Cladding Systems pass*[™]. This document defines the scope of use and limitations for the system and ensures that the systems are used within the scope of the CodeMark Certification.
- Hume Pine *Pineclad and Pinetrim XT Care and Maintenance*. This document describes how the systems should be maintained to ensure ongoing performance.
- Hume Pine *Pineclad and Pinetrim XT Horizontal and Vertical Weatherboard External Cladding Systems Warranty*.
- Hume Pine *CodeMark Design and Installation Declarations*.
- MBIE [January 2017] Acceptable Solutions and Verification Methods for New Zealand Building Code (NZ Building Code) Clause E2 External Moisture (refer to www.building.govt.nz).
- Department of Building and Housing (DBH) June 2006. *Constructing Cavities for Wall Claddings* (refer to www.building.govt.nz).
- BRANZ Bulletin BU468 [December 2005] *Fixing Timber Weatherboards* (refer to www.branz.co.nz).
- BRANZ [May 2015] *Good Practice Guide: Timber Cladding* (refer to www.branz.co.nz).
- BRANZ Bulletin BU582 [April 2015] *Structurally Fixed Cavity Battens* (refer to www.branz.co.nz).

When applying for a building consent, the Hume Pine documents along with a copy of the current CodeMark Certificate of Conformity should be included. The signed Hume Pine CodeMark Installation Declaration should be submitted with the code compliance certificate (CCC) application.

All documents are available from www.humepine.nz.



Description

The systems comprise timber weatherboards, fascia boards, and associated system moulding profiles manufactured from finger-jointed, glue laminated, clear radiata pine and cavity battens.

The 18mm thick weatherboards are available in the following widths and profiles:

Profile	135mm	142mm	180mm	187mm
Rusticated	✓		✓	
Bevelback	✓	✓	✓	✓
Rebated Bevelback	✓			
Bevel Rustic	✓			

Rusticated, Rebated Bevelback, and Bevel Rustic weatherboards are profiled to provide a 25mm rebate, ensuring a 2mm gap that allows for expansion.

Bevelback Weatherboards are profiled to be installed with a 32mm overlap.

Other components supplied as part of the systems are:

- Fascia Boards: Available in 18mm and 29mm thicknesses and widths of 135mm, 180mm, 230mm and 280mm.
- Moulding profiles: Bevelled Cornice, Quad, Scotia, Scriber, D4S, D4S Eaves Mould (with arised edge), Weather Grooved Boxed Corners, Sill, and Rustic Plug.
- 45 x 19mm finger-jointed H3.1 LOSP radiata pine cavity battens
- Custom-made weatherboards, fascia boards, and moulding profiles: available on request.

Pineclad & Pinetrim XT Horizontal Weatherboard Profiles

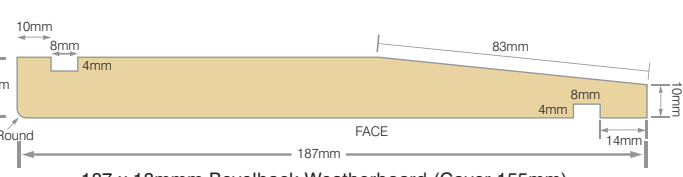
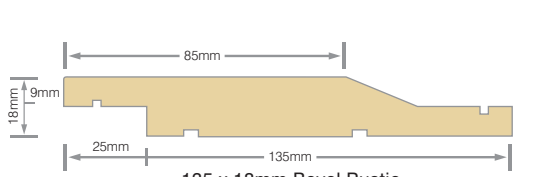
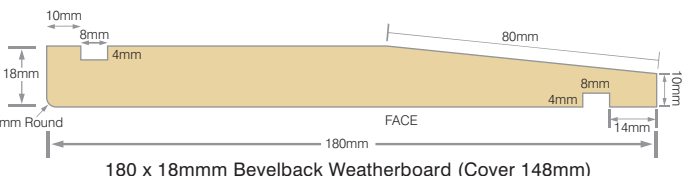
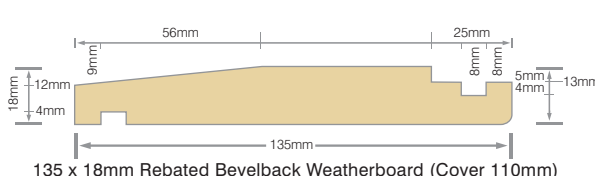
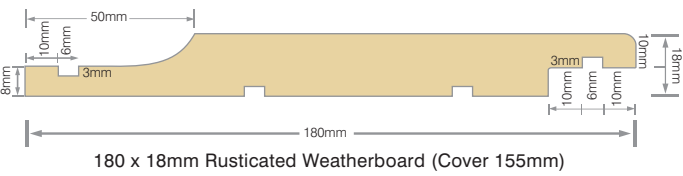
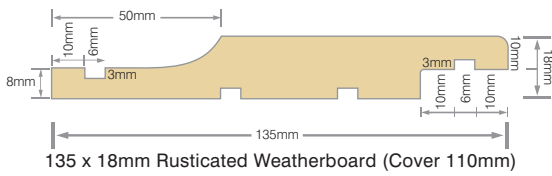
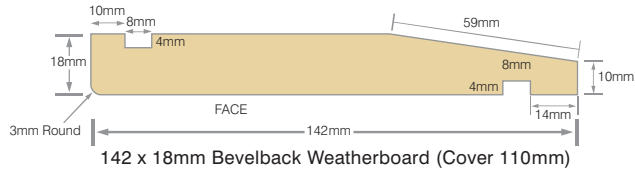
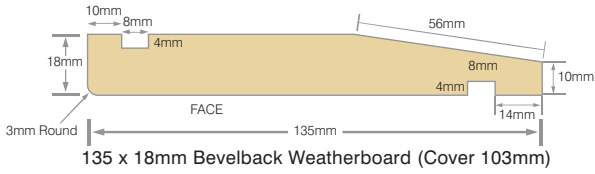

Optional Exterior Pineclad & Pinetrim XT Profiles

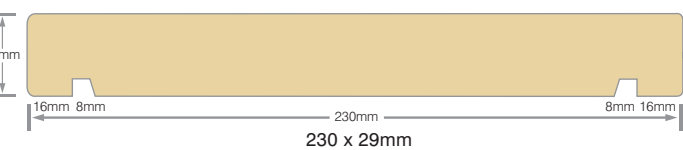
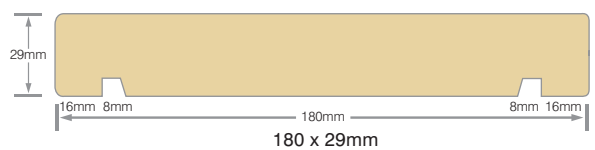
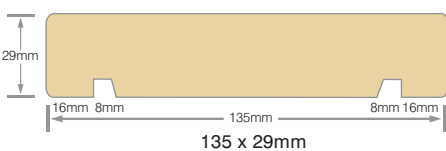
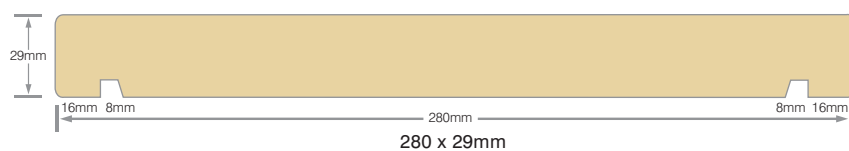
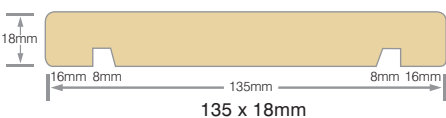
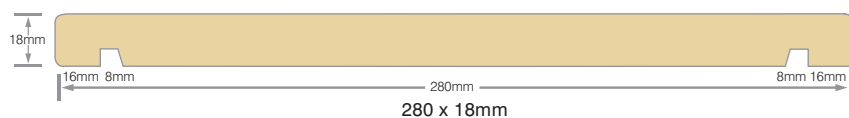
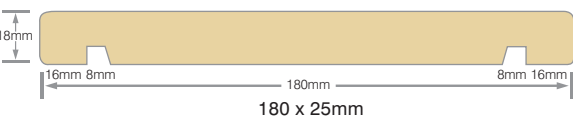
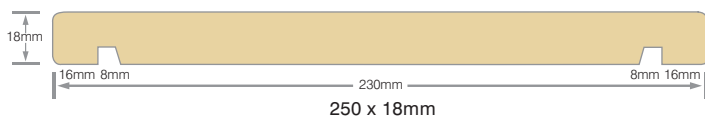

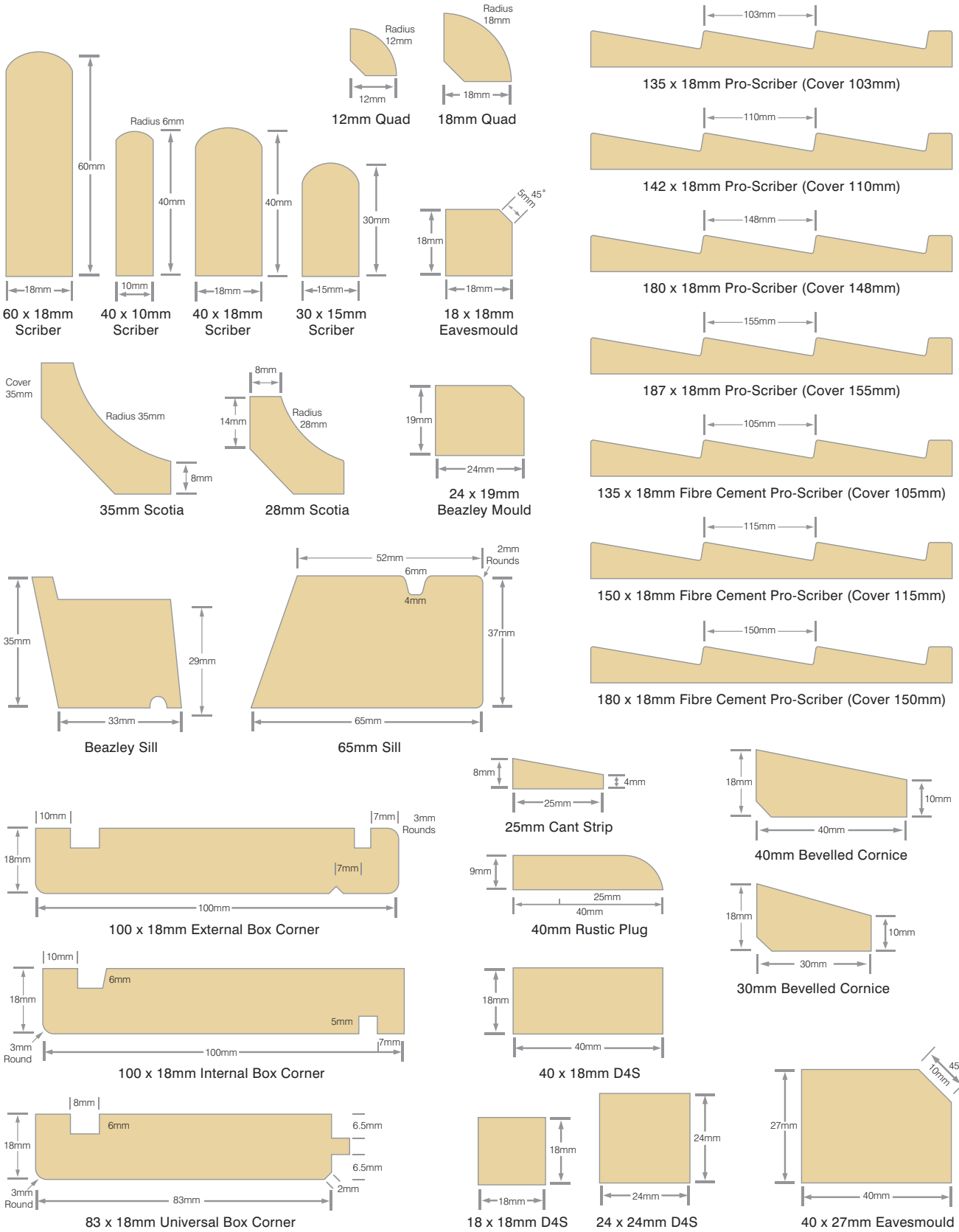

Information For Designers

Skills Required

You must have knowledge of the systems and access to all Hume Pine technical information (refer to www.humepine.nz) and all relevant regulatory information (refer to www.building.govt.nz).

Where restricted building work (RBW) provisions apply, you must be able to meet your obligations.

Considerations When Designing

You must ensure that the project falls within the scope of the systems (refer to the Hume Pine, Pineclad and Pinetrim XT Horizontal Weatherboard External Cladding Systems pass[™]).

Please note that whilst E2/AS1 allows for face fixed installation where the risk matrix is less than or equal to 12, Hume Pine recommends that the systems are always installed over a drained and ventilated cavity.

You must also consider the following indicative list:

- exposure zones/durability requirements of all fastenings;
- Wind zone/specific wind pressure;
- Climate zone;
- Location of building on-site and proximity to relevant boundaries;
- Compliance of the building work with all relevant provisions of the New Zealand Building Code, including but not limited to:
 - Suitability of the existing building,
 - Structural framing requirements during the construction phase and once completed;
 - Risk calculation using the E2/AS1 risk matrix; and
 - Other materials likely to affect the product's performance.

The details do not refer to specific trade brands of fixings, building wrap, rigid air barrier, or sealing tape. You must ensure that selected products comply with the New Zealand Building Code and are suitable for the specific location of the building project.

Information For Installers

Skills Required

You must have knowledge of the system and access to all Hume Pine technical information (refer to www.humepine.nz) and all relevant regulatory information (refer to www.building.govt.nz).

Where RBW provisions apply, you must ensure that you are able to meet your obligations.

Handling

Hume Pine recommends that the products are unloaded by hand. Long lengths should be carried on edge, not on their flat.

If mechanical means are used, ensure that there is a minimum of two well-spaced points to avoid excessive bending or sagging.

When using a crane, you may need to consider a spreader bar.

Storage

If stored on-site, the product must be stacked flat on a dry surface, which is at least 150mm off the ground and under cover.

The dunnage strapped to the bottom of the packet and associated packaging material is for transport purposes only and is not suitable for use as on-site storage.

Ensure the area where the product is stored is dry, well-ventilated and out of direct sunlight.

Health & Safety

Take all necessary steps to ensure your safety and the safety of others, including:

- Ensuring there is adequate ventilation or mechanical dust extraction when cutting or drilling;
- Ensuring the timber is well supported when cutting and nailing;
- Wearing appropriate safety equipment and appropriate clothing and footwear;
- Using all tools in accordance with relevant instruction manuals;
- Planning and monitoring a safe approach for working at height including selecting and using the right equipment;
- Clearing the work area of any obstructions before work starts.

For further information refer to:

- WorkSafe [July 2018] *Small Construction Sites, The Absolutely Essential Health and Safety Toolkit*.
- WorkSafe [December 2016] *Health and Safety at Work, Quick Reference Guide*.

These documents are available at www.worksafe.govt.nz.

Tools Required

General carpentry and woodworking tools are all you will need to install the system.

Note: Power driven nail guns may be used to install cavity battens.

Installation Requirements

Refer to the typical details at the end of this Design and Installation Guide to assist in the installation of the systems.

The following requirements must be satisfied:

Framing & Flexible Underlay or Rigid Air Barrier

Prior to installing the systems ensure:

- The framing and underlay or rigid air barrier has been installed so that it complies with the New Zealand Building Code (for new building work) or is suitable for the installation of the systems (for existing buildings);
- Framing tolerances are in accordance with Section 2.1, NZS 3604:2011;
- Moisture content of the framing is no greater than 18%;
- The framing and underlay have been installed in accordance with relevant specification or supplier information;
- A rigid air barrier (in accordance with Table 23 of E2/AS1) has been installed in unlined gables and walls;
- Underlay in accordance with Paragraph 9.1.3.4 of E2/AS1 has been installed in attached garages.

Fixings

Ensure that all materials are compatible in accordance with:

- Table 20 E2/AS1;
- Table 21 of E2/AS1;
- Table 22 of E2/AS1.

Fixings and fixing materials must be in accordance with:

- NZS3604:2011;
- Table 24 of E2/AS1;
- Paragraph 2.2 of E2/AS1.

A PVC tape bond break must be provided between H3.1 battens and any flashing.

Soakers and flashings must be fixed in accordance with:

- Section 4 and Table 6.12 of NZS3604:2011;
- Section 9 of E2/AS1.

A cavity closure strip must be installed in accordance with Paragraph 9.1.8.3 of E2/AS1.

All nail fixings should be pre-drilled with a diameter a minimum of 1mm smaller than the nail gauge.

All nails must be filled after installation to prevent moisture damage, prior to coating of the system.

Fixing of Structural Battens

Hume Pine supply timber cavity battens; 40mm x 19mm gauged, and treated to H3.1 as part of the systems.

These battens must be installed in accordance with BRANZ Bulletin BU582 [April 2011] *Structurally Fixed Cavity Battens* (refer to www.branz.co.nz).

Battens must be structurally fixed to the wall framing at 300mm centres or 1 nail per stud and 2 nails per nog with:

- 60mm x 2.8mm galvanised jolt head nails, or
- Power-driven 60mm x 2.87mm galvanised nails, or
- Power-driven 64mm x 2.8mm stainless steel annular-grooved nails.

Aluminium Joinery

Aluminium joinery and flashings must be installed in accordance with the manufacturer's instructions.

A 7.5mm – 10mm nominal gap must be left between the reveal and wall framing to allow a PEF rod and air seal to be installed in accordance with Paragraph 9.1.6 of E2/AS1.

Weatherboards

Prior to installing the systems:

- Ensure the moisture content of the products is no greater than 16%. Allow to dry if necessary.
- Check the products for any defects or damage and remove any dirt, dust, or stones.
- Ensure all cut ends, edges, and areas where the supplied coating has been damaged are sanded smooth, end sealed and recoated. For Pinetrim XT only quality acrylic primer and top coat systems may be used.
- Hume Pine recommends that all nail fixings are pre-drilled, especially in areas around joins and the end of boards with a diameter a minimum of 1mm smaller than the nail gauge.

Installing the systems:

- Weatherboards are to be fixed with:
 - Galvanized 75mm x 3.15mm jolt head nails embedded a minimum of 20mm into wall framing where installed over structurally fixed battens, or
 - galvanized 90mm x 3.15mm jolt head nails embedded a minimum of 30mm into wall framing where the batten is not structurally fixed.
- Check that a minimum 2mm gap between weatherboards has been achieved for Rusticated, Rebated Bevelback and Bevel Rustic.
- For Bevelback weatherboards ensure a 32mm overlap is achieved.
- Bevelback weatherboards should be fixed so that the weather-groove on the back of the weatherboard matches the weather-groove of the face of the board beneath it.
- Hand nailing is recommended as nail guns can cause damage to the face and back of the board.



- Nail at an upward angle to prevent water movement down the nail into the wall space. All nails should be punched to a depth of 3mm – 4mm. All nails must be filled immediately after installation, with a suitable exterior filler, to prevent moisture damage, prior to coating of the system.

Ground Clearances

- Finished floor level must have minimum clearances in accordance with E2/AS1 and NZS 3604:2011.
- Weatherboards must overhang the concrete slab and bottom plate by a minimum of 50mm in accordance with Table 18 of E2/AS1.
- The bottom edge of the weatherboards must be:
 - Kept clear of adjacent surfaces, and
 - A minimum of 35mm above the top-surface of adjacent flashings at deck or low pitch roof/wall junctions.

Finishing

- For Pineclad, a primer undercoat and two top coats of high-grade acrylic or oil-based paint must be applied to the system.
- For Pinetrim XT, two top coats of high-grade acrylic paint must be applied to the system.
- Paint must be applied in accordance with the manufacturer's instructions. Dark colours, with a Light Reflective Value (LRV) less than 45% should be avoided as they absorb heat and could cause excessive movement, distortion, or resin bleed.

For further information refer to:

- NZS2311:2017 *Guide to the Painting of Buildings*

Typical Details

The following typical details and nailing patterns have been prepared to assist in the specification and installation of the systems and demonstrate compliance with the NZ Building Code. This information is in consistent with Acceptable Solution E2/AS1 and BRANZ Good Practice Guide for Timber Cladding.

The details are described as typical as there are design options and minor variations that may be required. Where used in conjunction with other cladding systems, the designer must assure themselves that the junction will meet all relevant Building Code provisions including those of Clause E2 External Moisture of the NZ Building Code.

Details supplied:

- Fig 1: Window Sill Detail
- Fig 2: Window Jamb Detail
- Fig 3: Window Head Detail 1
- Fig 4: Internal Corner Detail 1
- Fig 5: External Mitre Corner Detail
- Fig 6: Internal Corner Detail 2
- Fig 7: External Box Corner Detail
- Fig 8: Upper Storey to Soffit Detail
- Fig 9: Weatherboard to Soffit Detail
- Fig 10: Typical Joint Junction Detail
- Fig 11: Bottom Edge Detail

Window Sill Detail (Fig 1)

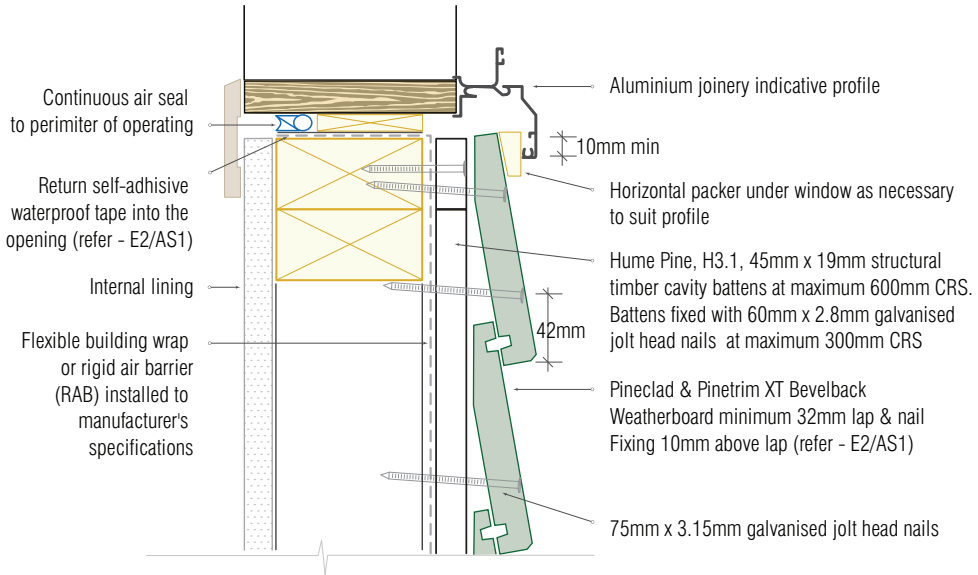

Window Jamb Detail (Fig 2)

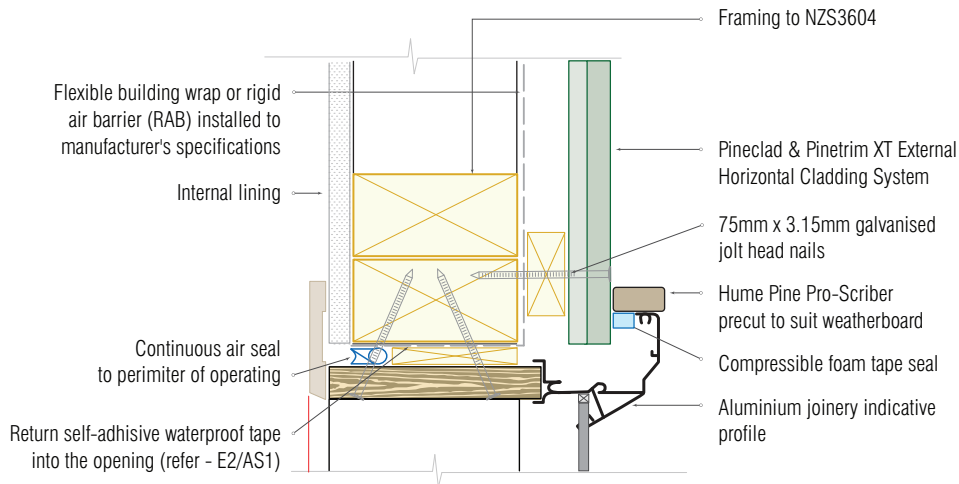

Window Head Detail 1 (Fig 3)

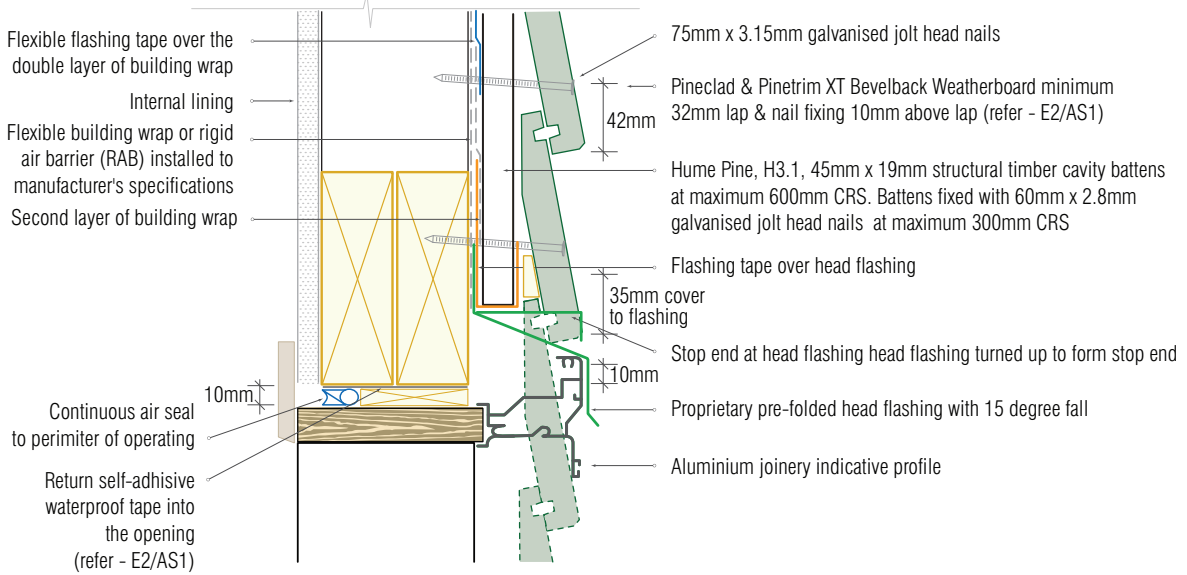

Internal Corner Detail 1 (Fig 4)

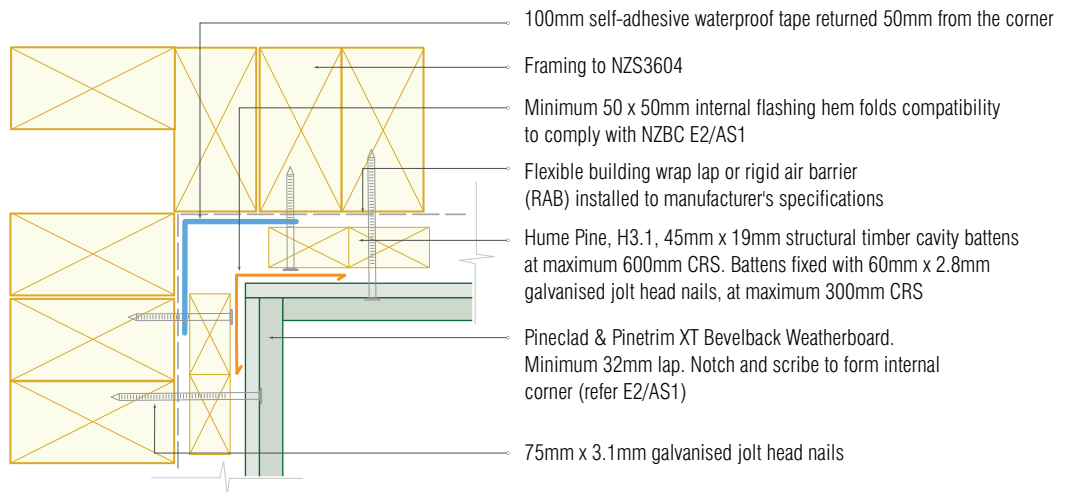

External Mitre Corner Detail (Fig 5)

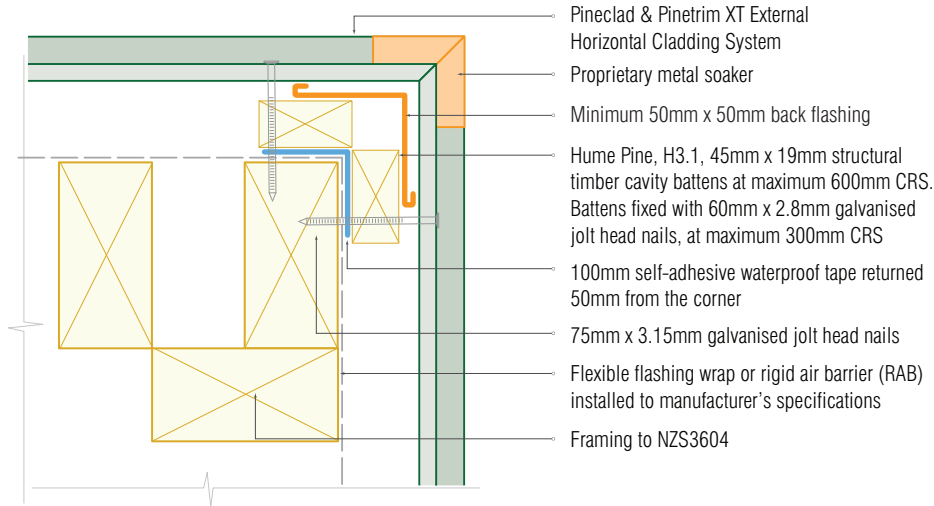

Internal Corner Detail 2 (Fig 6)

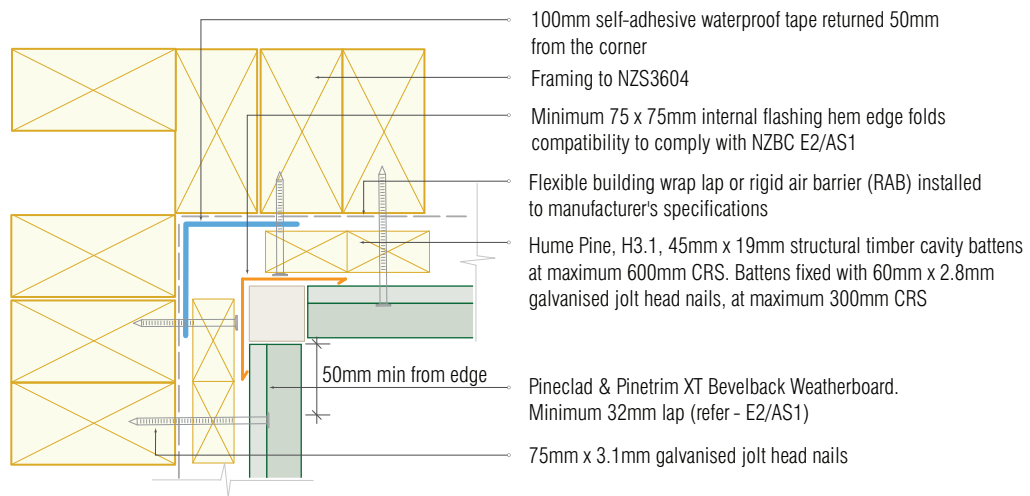

External Box Corner Detail (Fig 7)

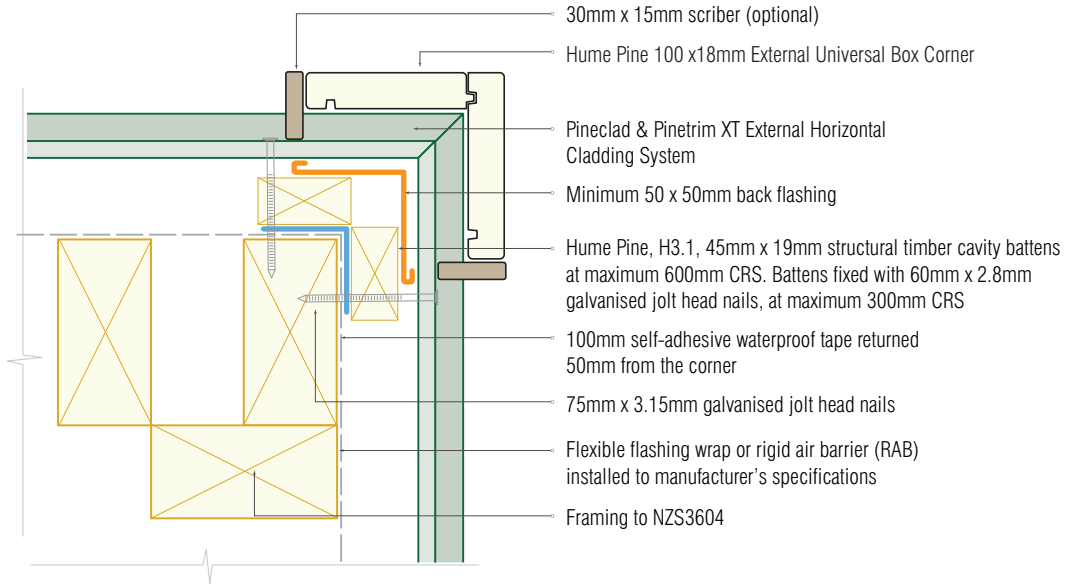

Upper Storey to Soffit Detail (Fig 8)

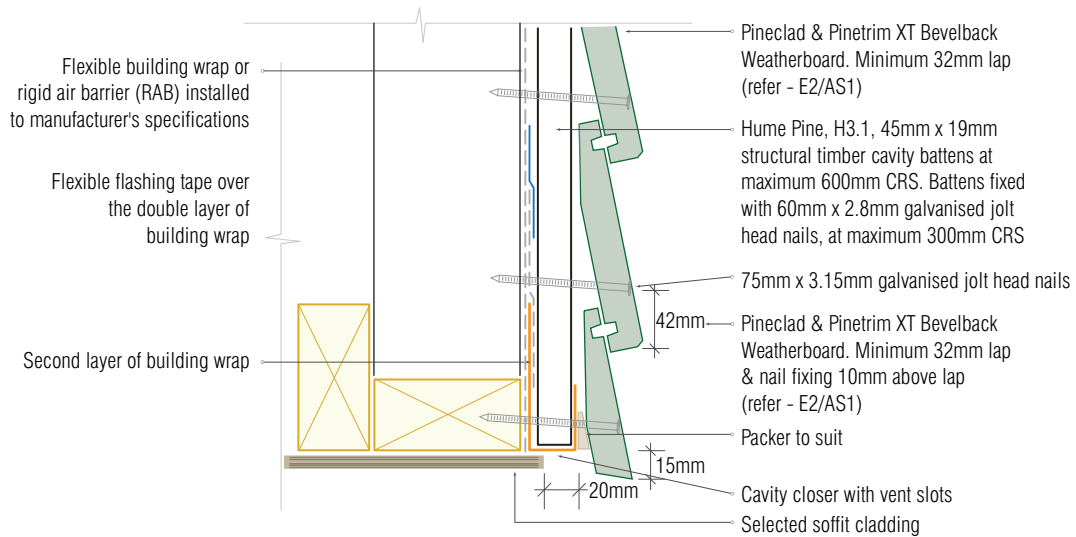

Weatherboard to Soffit Detail (Fig 9)

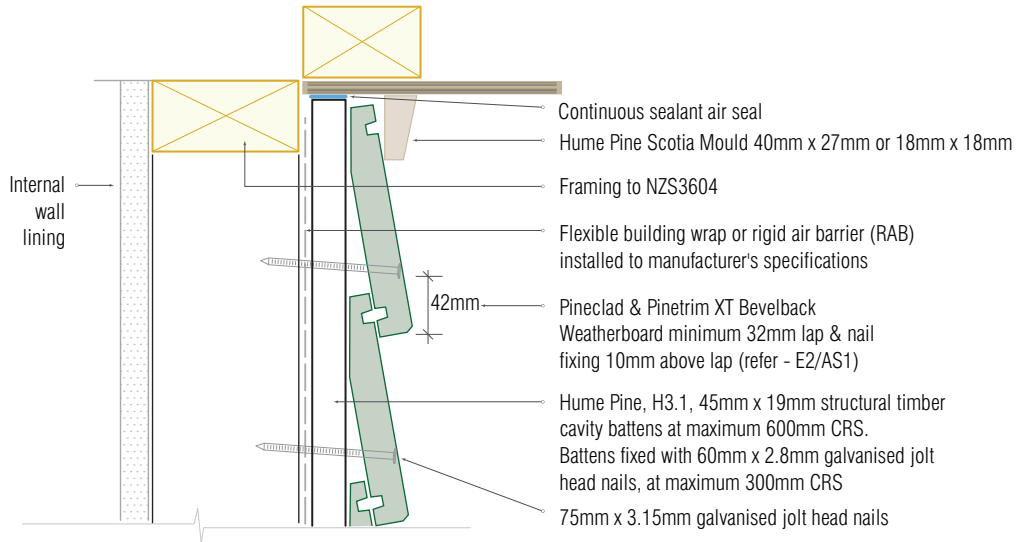

Typical Joint Junction Detail (Fig 10)

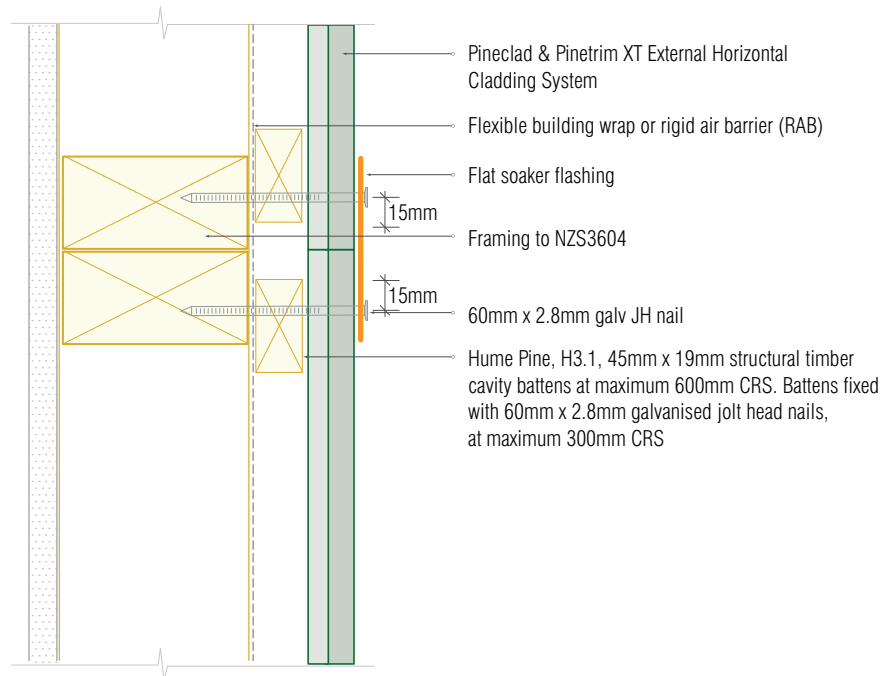

Bottom Edge Detail (Fig 11)

