

PRODUCT MEM2400LP

MEM MECHANICAL ELECTRO MAGNETIC LOCKING DEVICE
FOR OUTWARD OPENING HINGED DOORS



MEM2400LP



PRODUCT DESCRIPTION

The innovative slimline MEM2400LP Mechanical Electro Magnetic Lock has been designed as an alternative to standard magnetic locks especially suited for situations where door height or narrow profile door frames create installation restrictions and appearance is of paramount importance.

The patented MEM incorporates both magnetic and mechanical design principles to achieve a superior holding force of up to 1000kg, whilst being 75% smaller than a standard 600kg Electro Magnet.

The MEM2400 is capable of opening with up to 70kg side pressure on the door and has the added security function of "Early Warning" alarm condition. The device comes with the FSH patented "Anti-Tamper-Bracket" as standard.

TECHNICAL DETAILS

PART NO.	MEM2400LP
LIGHT FEATURE	Light Panel (LP)
FUNCTION	Surface mount Outward opening doors
HOLDING STRENGTH	Up to 1000kg
VOLTAGE/CURRENT	Dual Voltage 12/24VDC 12VDC/240mA 24VDC/120mA
APPROVALS	4 hour fire rated to A.S. and B.S. standards
MONITORING	EW / LSS / DSS
SIZE	MEM size L= 158mm H= 35mm D= 30mm Armature Plate size L= 120mm H= 30.6mm D= 12.5mm Anti-Tamper-Bracket size L= 194mm H= 38mm D= 30mm

PRODUCT FEATURES

- Slimline design 75% smaller than a standard 600kg magnet
- High holding force up to 1000kg and releases under side load of up to 70kg
- Dual-Voltage 12/24VDC Low power consumption 24VDC/120mA
- 5 year warranty
- Simple installation
- 4 hour fire rated
- Full monitoring Lock Status Sensor (LSS) and Door Status Sensor (DSS)
- Early Warning Alarm (EW)
- Anti Tamper Bracket (to protect the armature plates fixing bolt)

NEW GENERATION ELECTRIC AND ELECTRONIC LOCKING



PRODUCT DIMENSIONS AND INSTALLATION

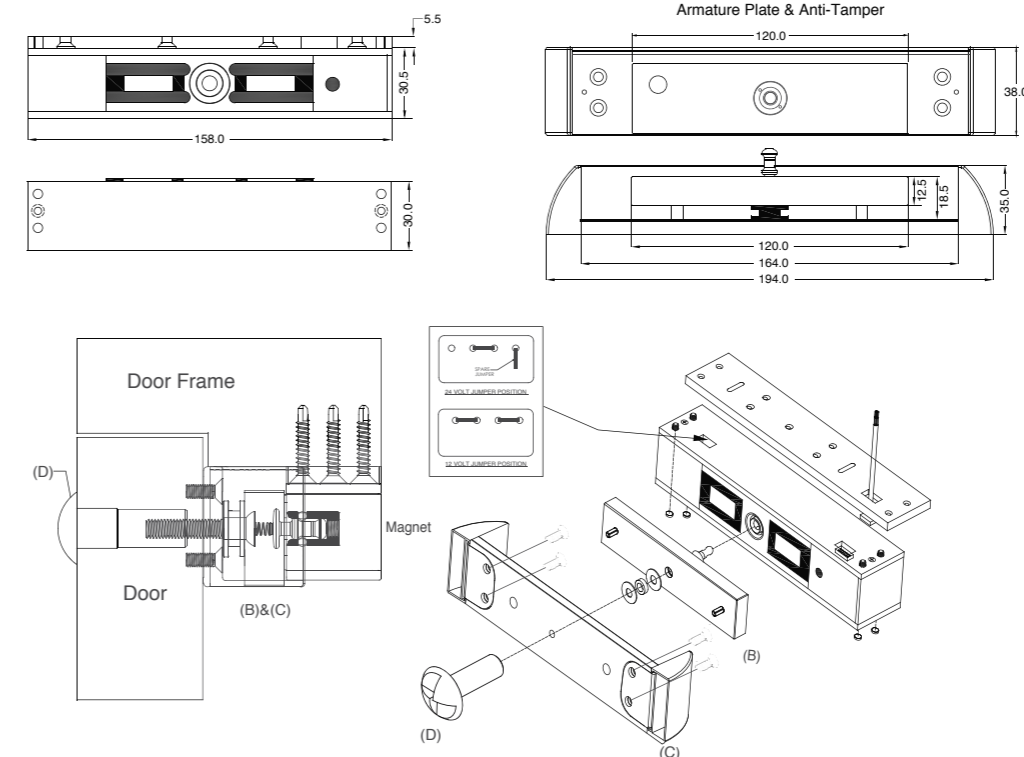

ACCESSORIES

MEM2400L Adjustable L-Bracket for Narrow Header Frames

AMGB24-12 Glass Door Bracket U-Profile

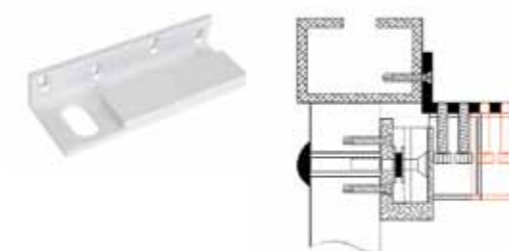

PART NO. MEM2400L

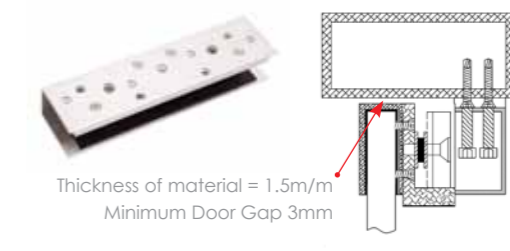

PART NO. AMGB24-12