

Keylite Centre Pivot - Trim Size					
Model No.	Keylite Overall		Trim Size		
	wide	high	wide	high	
CP-01	550	x 780	590	x 820	
CP-02	550	x 980	590	x 1020	
CP-04	780	x 980	820	x 1020	
CP-05	780	x 1180	820	x 1220	
CP-06	780	x 1400	820	x 1440	
CP-08	1140	x 1180	1180	x 1220	
CP-08F	1140	x 1400	1180	x 1440	

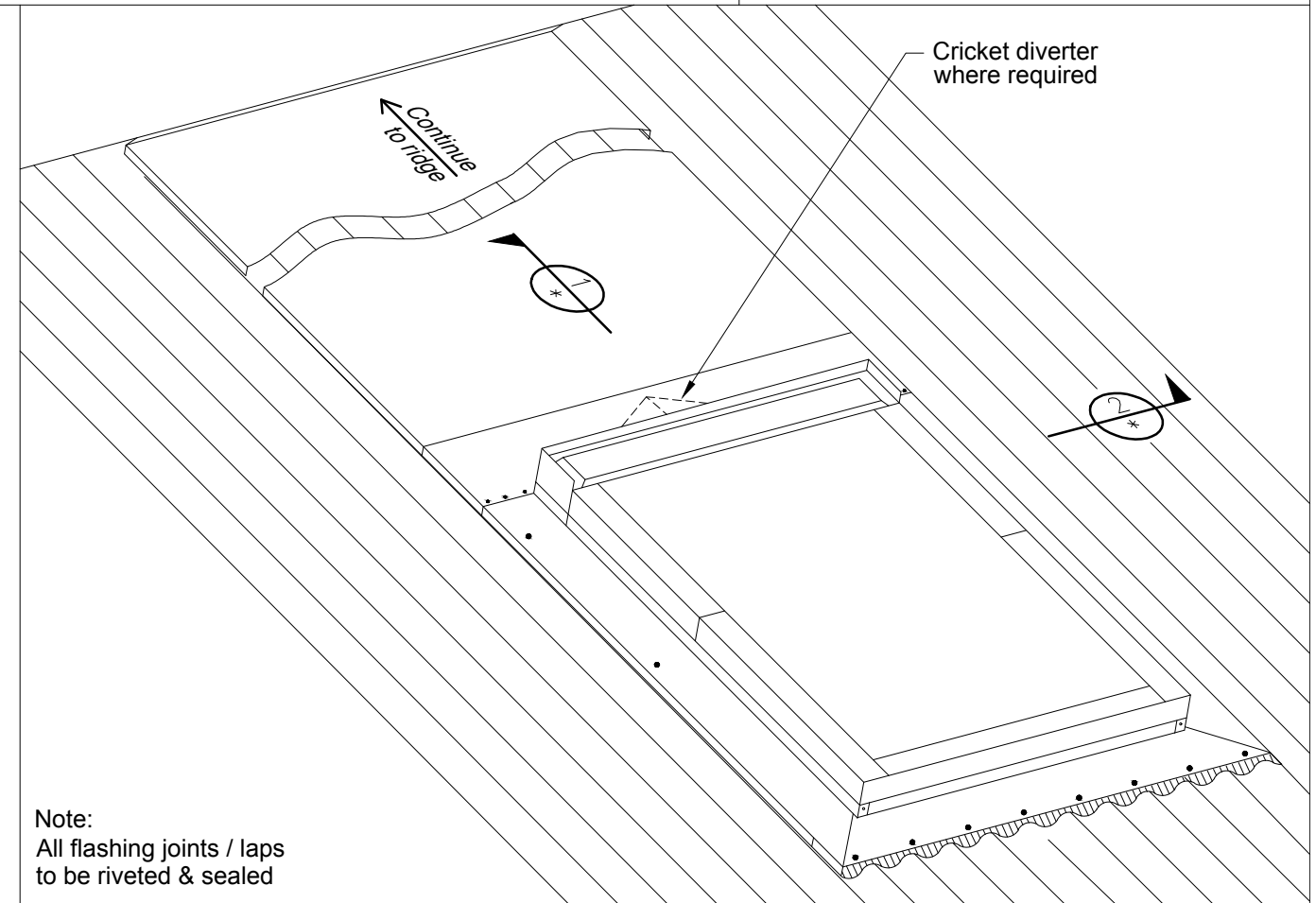

Note:
All flashing joints / laps
to be riveted & sealed

Not to scale, do not scale from drawing. All details are generic in nature and should be read in conjunction with the roofing manufacturers' standard penetration details.

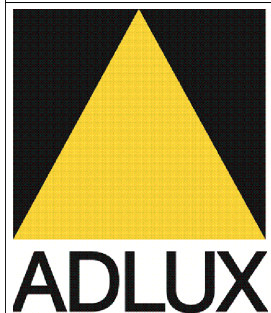

ADLUX Industries Ltd. ©
36 Olive Road, Penrose
P.O. Box 13866, Auckland
New Zealand.
Ph: (09) 636 6866
Fax: (09) 636 6846
Email: sales@adlux.co.nz

CENTRE PIVOT CORRUGATED ROOFING PROFILE (Back Tray) PITCH 15° TO 60°



DATE: 14/02/19

DWG No: CP-CR-BT