

SV450/600/900 Industrial Ventilators

INSTALLATION GUIDE

COMPONENTS

VENTILATOR HEAD

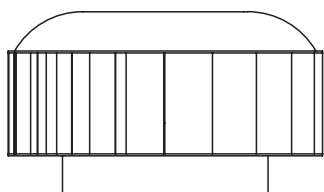

VARIABLE PITCH BASE

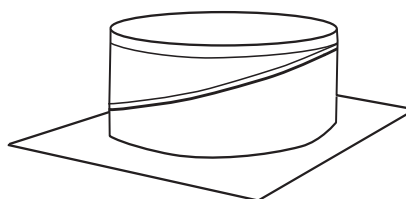

DAMPER (OPTIONAL)

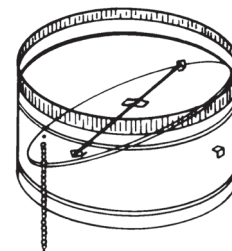

INSTALLATION

(A) UNDER RIDGE FLASHING

(B) AWAY FROM RIDGE FLASHING

STEP 1

Position on roof under ridge flashing (A) (recommended) Away from the ridge flashing (B)

Ideally, the vent should be as close as possible to the ridge line. Place the base on the roof with the top edge slipped under the ridge capping. Alternatively a flashing is required as depicted in the diagram (B) for installations away from the ridge flashing.

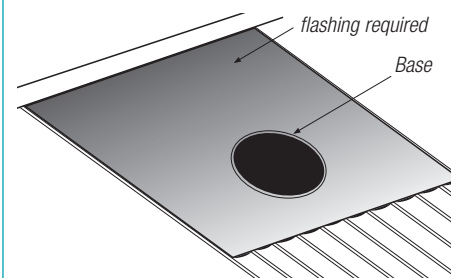
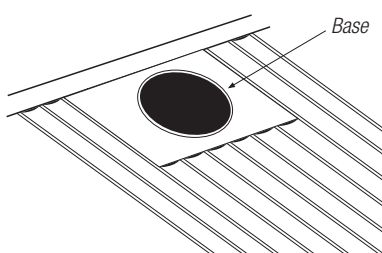

STEP 2

Cutting the hole

Mark the proposed hole using the base as a template. Once marked, cut the hole using appropriate metal roofing cutting tools.

Securing and dressing the flashing

Turn up the corrugations of the metal roof within the cut hole. Secure the flashing to the sheeting with self tapping screws or rivets (not included - a minimum of 10 are recommended).

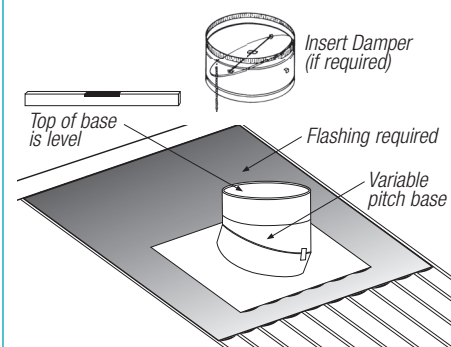
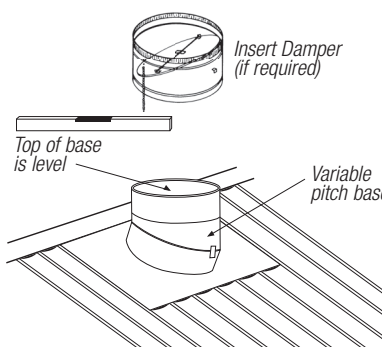

STEP 3

Fitting the variable pitch throat

Fit the variable pitch throat to suit the pitch of the roof. Use a spirit level to ensure the final position is level.

Fixing the variable pitch throat

Fix the (4) clamping clips supplied across the Varipitch throat seam with either rivets or screws (not supplied), at approximately 90° to each other.

ADD DAMPER AT THIS POINT - IF USING.

STEP 4

Sealing and locking the variable pitch throat

To ensure a water tight system, silicone seal all seams and joints from the inside of the variable pitch throat.

STEP 5

Fitting the turbine

Position the turbine head lining up the pre-drilled holes in the brackets with those of the variable pitch throat. Fasten with screws provided. Finally silicone seal the outside seam of the Varipitch and base. It is recommended for 900mm rotary vent size, solid support between purlins is installed. Failure to do so can result in needless movement of the vent in high winds. Failure to provide correct support will result in loss of warranty.

