

PRODUCT FES90M-P
 HIGH SECURITY ELECTRIC EcoStrike™
 WITH PRE-LOAD CAPABILITY – AUSTRALIAN FOOTPRINT



FES90M-P



PRODUCT DESCRIPTION

The patented FES90M-P motorised High Security Electric EcoStrike with up to 35kg Pre-Load capability is a revolutionary electric locking solution. With a high Pre-Load /Side-Load tolerance and minimal energy consumption in 'Sleep-Mode' it is a truly "Green Locking Solution".

The strike accepts voltages from 10 to 30VDC, is pre-drilled for extension lips and has a unique and simple fail secure (Power To Open)/ fail safe (Power To Lock) switch-over function.

The door strike provides 3 forms of monitoring:

1. LSS (Lock Status Sensor)
2. DSS (Door Latch Sensor)
3. DPS (Door Position Sensor)

To utilise the Door Position Sensor monitoring function (DPS), FSH is providing special Mortice Lock Face Plates equipped with magnets, as separate items (see Accessories). These Face Plates work in conjunction with the FES90M-P built in Reed Switch.

The electric strike consumes current less than 300mA @ 12VDC at full 35kg pre-load only during locking and unlocking action. In the locked or unlocked state (Sleep-Mode), the electric strike consumes current less than 15mA@12VDC.

FES90MP comes with a 10mm strike lip as standard, to prevent possible personal injury and damage to clothing as with 15mm lips.

TECHNICAL DETAILS

PART NO.	FES90M-P
FUNCTION	Mortice Mount, Power-To-Lock/Power-To-Release field interchangeable, 35kg of Pre-Load capability
HOLDING STRENGTH	Up to 1370kg Tested to 1.5Mill full 35kg pre-load cycles
VOLTAGE/CURRENT	Multi Voltage 10-30VDC Action Mode: 300mA@12VDC at full 35kg pre-load only during locking and unlocking action Sleep-Mode: 15mA @ 12VDC in locked or unlocked mode
APPROVALS	4 hour fire rated to A.S. and B.S. Standards CE C-TICK
MONITORING	LSS - Status Sensor of the internal locking mechanism DSS - Door Latch Sensor, Door latch engaged within strike keeper DPS - Reed Switch Built-in, monitoring the door position
ENVIRONMENTAL	Operational Temperature Range -20° to +60°C

PRODUCT FEATURES

- Releases with up to 35kg of Pre-Load/Side Load
- Motorised locking device
- Durability tested to 1.5 Mill. full pre-load cycles of 35kg
- Multi voltage from 10 to 30VDC
- Sleep Mode Current less than 15mA@12VDC
- Weather resistant
- Fully monitored including Reed Switch for door position
- Pre-drilled for extension lips
- Up to 1300kg holding strength
- 5 year warranty
- Guaranteed shock/hammer resistant

PRODUCT DIMENSIONS AND INSTALLATION

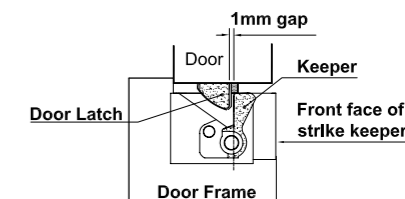
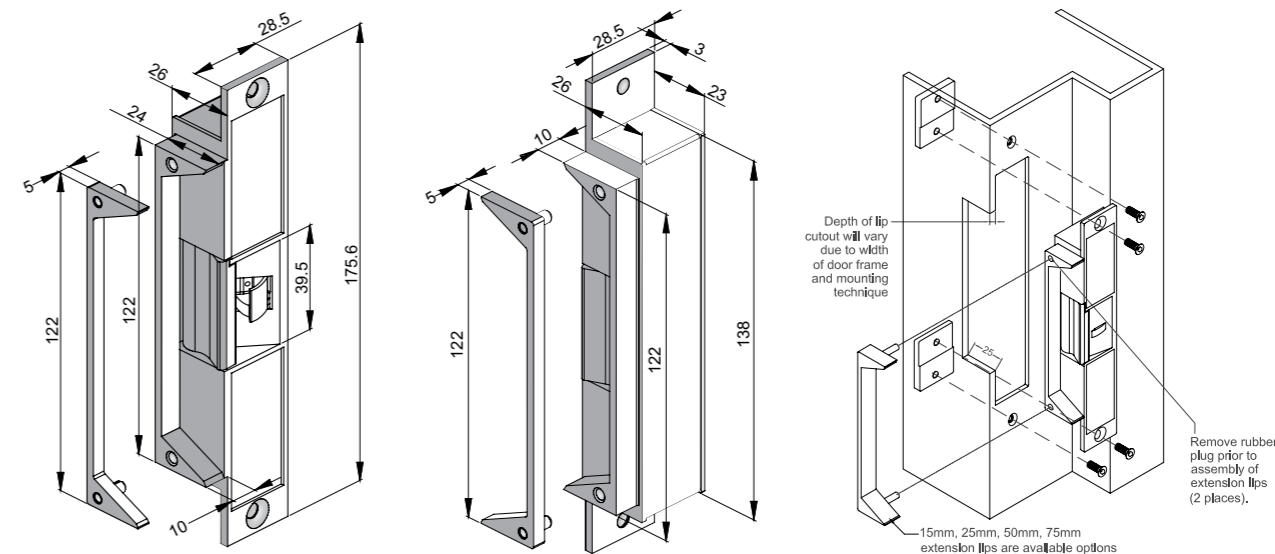

ORDER DETAILS & ACCESSORIES

PART NO.	PRODUCT DESCRIPTION
FES90M-P	High Security Electric Eco Strike with pre-load capabilities Australian Footprint monitored 10mm Lip
FES20-EL15	FES20 Extension Lip 15mm
FES20-EL25	FES20 Extension Lip 25mm
FES20-EL50	FES20 Extension Lip 50mm
FES20-EL75	FES20 Extension Lip 75mm
FES20MR-AUS	Mortice Lock Faceplates with monitoring magnets for Aust. Lock Company Mortice Lock
FES20MR-DOR	Mortice Lock Faceplates with monitoring magnets for Dorma Mortice Lock
FES20MR-KAB	Mortice Lock Faceplates with monitoring magnets for KABA Mortice Lock
FES20MR-LEG	Mortice Lock Faceplates with monitoring magnets for LEGGE Mortice Lock
FES20MR-LOC	Mortice Lock Faceplates with monitoring magnets for Lockwood Mortice Lock
FES20MR-LOC-NS	Mortice Lock Faceplates with monitoring magnets for Lockwood Narrow Style Mortice Lock
FES20MR-NOV	Mortice Lock Faceplates with monitoring magnets for Novas Mortice Lock
FES20-Rebate	Rebate Kit for FES20 Series (Stainless Steel)