

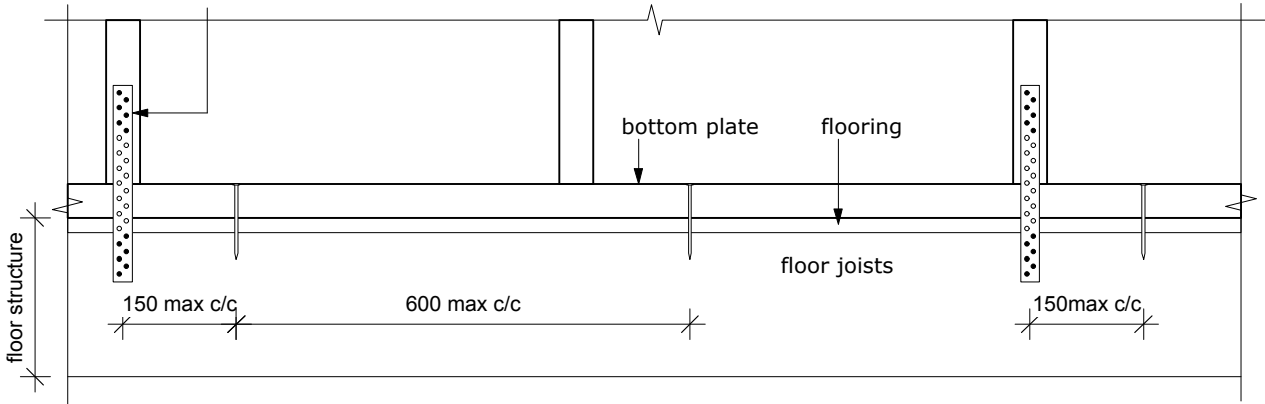

Fibre Cement

BGC - DS1 & DS2
Secure every 2nd stud (at sheet sides) to floor joists with 260x25x1.0mm galv mild steel strap, fixed each end with 6/30x2.5mm galvanised flat head nails



**Brace Panel Hold Down - Construction Detail
BGC - DS1 (1200mm) & DS2 (2400mm)
Timber Floor**

Direct Fix & Cavity

BGC - DS3 & DS4
Secure every 2nd stud (at sheet edge) to bottom plate with 130x90x130x25x1.0mm galv mild steel "U" bracket, fixed each end with 6/30x2.5mm galvanised flat head nails.

M12 Hold Down Bolts, 75mm into concrete foundation/floor, with 50x50x3.0mm HD Galv sq washer

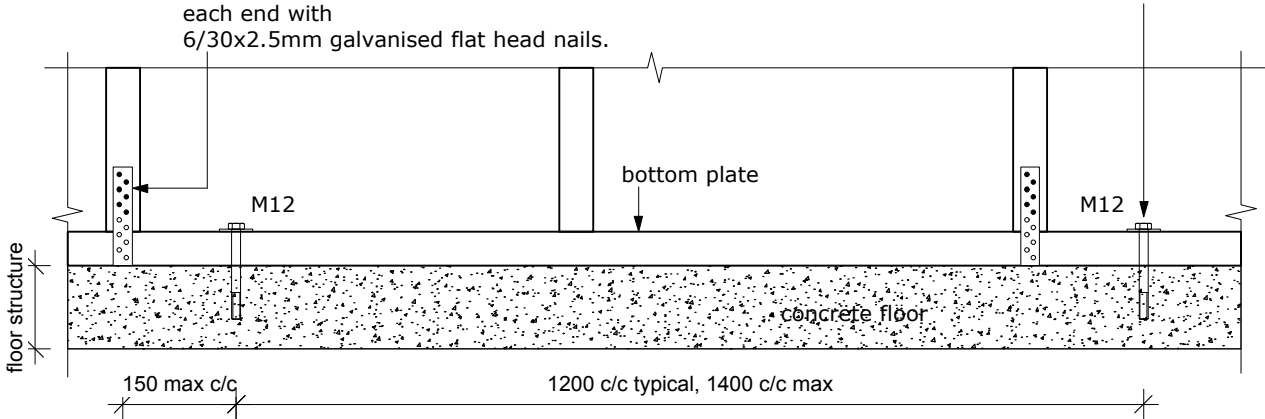

**Brace Panel Hold Down - Construction Detail
BGC - DS3 (1200mm) & DS4 (2400mm)
Concrete Floor**

Direct Fix & Cavity

PROFILE BGC Durasheet™

DATE Feb 2010

DETAIL Brace Element Hold Down

SCALE 1:10 @ A4

DETAIL NO. D28