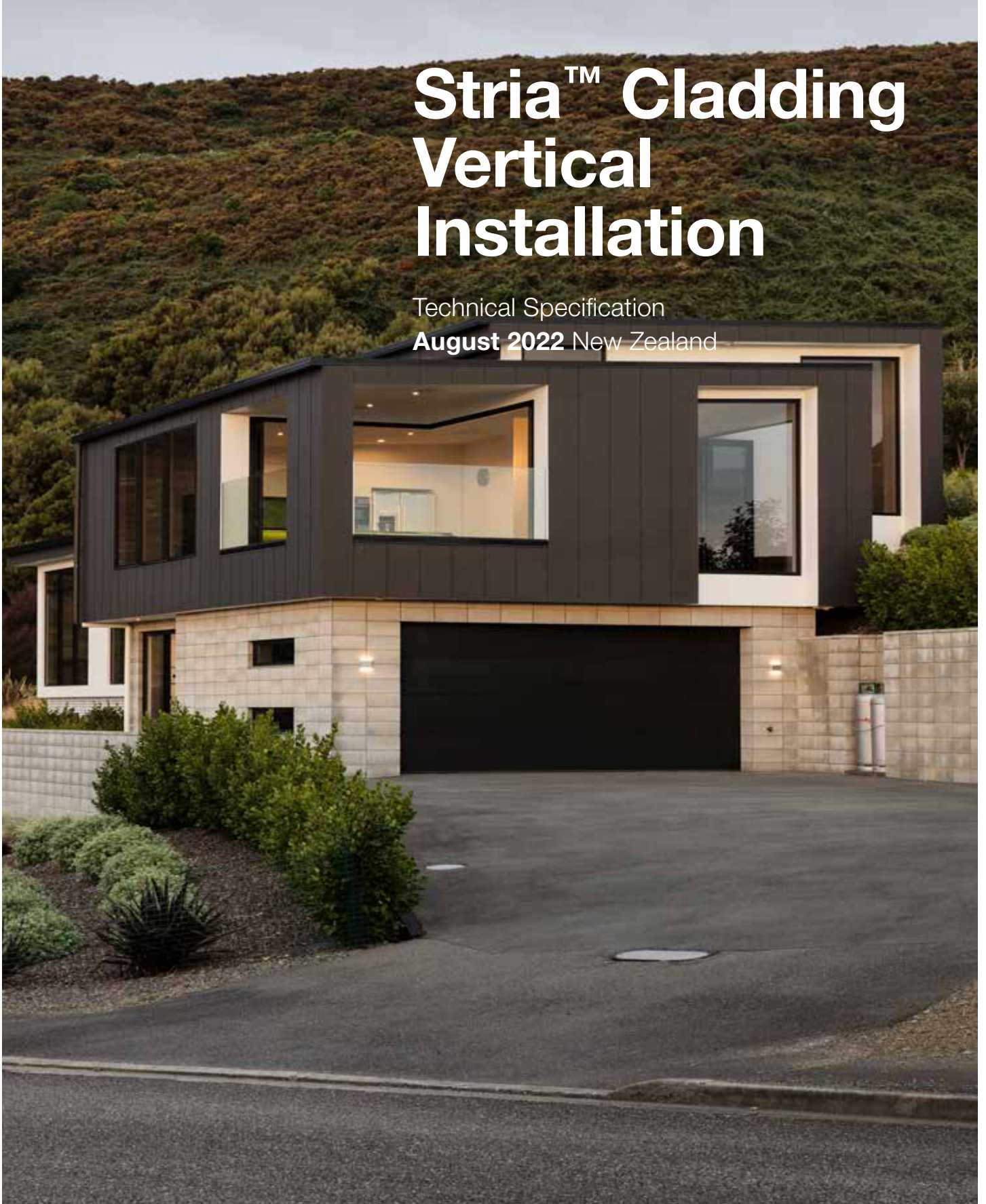


# Stria™ Cladding Vertical Installation

Technical Specification

August 2022 New Zealand





## We value your feedback!

To continue with the development of our products and systems, we value your input. Please send any suggestions, including your name, contact details, and relevant sketches to:

**Ask James Hardie™**  
[literaturefeedback@jameshardie.co.nz](mailto:literaturefeedback@jameshardie.co.nz)

### **Make sure your information is up to date**

When specifying or installing Hardie™ fibre cement products, ensure that you have the current manual. Additional installation information, warranties and warnings are available at [www.jameshardie.co.nz](http://www.jameshardie.co.nz) or **Ask James Hardie™** on **0800 808 868**.

# Contents

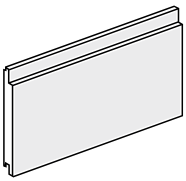
<b>1</b>	<b>Product Overview</b>	<b>4</b>	<b>6</b>	<b>Installation</b>	<b>14</b>
1.1	Product Information	4	6.1	Fastener	14
1.2	Manufacturing and Classification	4	6.1.1	Fastener – Size and Layout	14
1.3	Components and accessories	5	6.1.2	Fastener Durability	16
<b>2</b>	<b>Application and Scope</b>	<b>7</b>	6.2	Framing	16
2.1	Application	7	6.2.1	Special Framing Requirements	16
2.2	Scope	7	6.2.2	Tolerances	16
2.3	Details	7	6.2.3	Frame Construction	16
2.4	Specific Design	7	6.3	Flexible Underlay or HomeRAB™ Pre-Cladding	17
<b>3</b>	<b>Compliance</b>	<b>8</b>	6.4	Intermediate support for flexible underlays	17
3.1	Compliance	8	6.5	RAB™ Board	17
<b>4</b>	<b>Design</b>	<b>8</b>	6.6	Flashings	17
4.1	Responsibility	8	6.7	Cavity Closure/Vent Strip	17
4.2	Site and Foundation	8	6.8	Cavity Battens	18
4.3	Clearances	8	6.9	Joints	18
4.4	Moisture Management	9	6.9.1	Vertical Joint	18
4.5	Structure	9	6.9.2	Horizontal Joint	18
4.5.1	Timber Framing	9	6.9.3	Drainage Joint	18
4.5.2	Dimensions	9	6.9.4	External Corner	18
4.5.3	Structural Grade	9	6.9.5	Internal Corner	18
4.5.4	Durability	9	6.10	Junctions and Penetrations	18
4.6	Wind Pressures	10	<b>7</b>	<b>Finishes</b>	<b>19</b>
4.7	Structural Bracing	10	7.1	Preparation	19
4.8	Energy Efficiency	10	7.2	Painting	19
4.9	Fire Rated Walls	10	7.3	Flexible Sealant	19
4.10	Control of External Fire Spread	10	<b>8</b>	<b>Care and Maintenance</b>	<b>20</b>
4.11	Durability	10	<b>9</b>	<b>Details Section Index</b>	<b>21</b>
4.12	Alpine Regions	10	<b>Product Warranty</b>	<b>59</b>	
<b>5</b>	<b>Safe Working Practices</b>	<b>11</b>			
5.1	Storage and Delivery	13			
5.2	Tips for Safe and Easy Handling of Stria™ Cladding	14			

# 1 Product Overview

## 1.1 Product Information

Stria™ Cladding installed as per this specification gives a vertical panelised appearance. Stria™ Cladding can be fixed to timber framed external walls. A wide range of colours can be used, varying from light to dark.

**Table 1**

Stria™ Cladding Information					
Product	Description	Size (mm)			Code
		Thickness	Length	Width	
	<b>Stria™ Cladding</b> A 14mm profiled panel for expressed jointed residential facades. Factory sealed on all six sides. Each panel has a manila white colour primer applied on its face, which accepts a wide range of paint finishes.	14	4200	405	<b>404263</b> <b>404063</b>
				325	

**Note:** All dimensions and masses provided are approximate only and subject to manufacturing tolerances. Stria™ Cladding is manufactured in 14.0mm thickness and has a mass of 16kg/m<sup>2</sup> at EMC. Stria™ Cladding is defined as a Light Weight Wall Cladding (not exceeding 30kg/m<sup>2</sup>) as per NZS 3604.

## 1.2 Manufacturing and Classification

Stria™ Cladding is an advanced lightweight cement composite cladding, manufactured using James Hardie formulation. Basic composition is Portland cement, ground sand, cellulose fibre and water. The product is easily identified by the name 'Stria™ Cladding'.








Stria™ Cladding is manufactured in Australia to the Australian/New Zealand Standard AS/NZS 2908.2 'Cellulose-Cement Products' (ISO 8336 'Fibre-Cement Flat Sheet').

Stria™ Cladding is classified Type A, Category 2 in accordance with AS/NZS 2908.2 "Cellulose-Cement Products".

For Safety Data Sheets (SDS) visit [www.jameshardie.co.nz](http://www.jameshardie.co.nz) or Ask James Hardie on **0800 808 868**.

## 1.3 Components and accessories





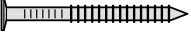

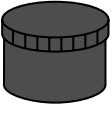
Table 2

Accessories/Tools supplied by James Hardie			
Accessories	Description	Size	Code
	<b>Hardie™ 20mm Horizontal Cavity Batten</b> H3.1 LOSP Timber treated batten the cladding is fixed over	2700mm long	305862
	<b>Hardie™ 14mm Trimline Joint Flashing</b> Aluminium extrusion used behind cladding at horizontal joints.	3000mm long	305827
	<b>Hardie™ 14mm Internal Corner Flashing</b> Anodised aluminum extrusion used to create internal corners..	3000mm long	304871
	<b>Hardie™ 14mm External Box Corner</b> Anodised aluminium extrusion used to create external corners.	2700mm long 4000mm long	305824 305823
	<b>uPVC Vent Strip</b> PVC moulding used as vermin proofing.	3000mm long	302490
	<b>Trimline Horizontal Jointer</b> A jointer to cover the butt joint of Stria Trimline Joint Flashing	100mm long	305871
	<b>Trimline External Corner Jointer</b> Joins Trimline Joint Flashing at an external corner		305870
	<b>Trimline Internal Corner Jointer</b> Joins Trimline Joint Flashing at an internal corner		305872
<b>Tools</b>			
	<b>Hardie™ Blade Saw Blade</b> Diamond tip fibre cement circular saw blade. Spacers not included.	184mm 254mm	300660 303375
	<b>Hardie™ Flex Stainless Steel 316 Nails</b> 75 x 3.15mm For fixing panels through cavity battens.		304253
	<b>Hardie™ Flex Hot Dip Galv. Nails</b> 75 x 3.15mm For fixing panels through cavity battens		304251

**Table 3**

**Accessories/Tools not supplied by James Hardie**

James Hardie recommends the following products for use in conjunction with Stria™ Cladding, HomeRAB™ Pre-Cladding and RAB™ Board. James Hardie does not supply these products and does not provide a warranty for their use. Please contact component manufacturer for information on their warranties and further information on their products.

Product	Description
	<p><b>Flexible underlay</b> Must comply with Table 23 of E2/AS1.</p>
	<p><b>Flexible window opening flashing tape</b> A flexible self-adhesive tape used in preparation of a window. Refer to the window installation section in this manual for more information. e.g. Protecto® or Super-stick building tape® by Marshall Innovation or 3M™ All Weather Flashing Tape 8067 by 3M™ Marshall Innovation: 0800 776 9727 3M™: 0800 474 787</p>
	<p><b>Flexible sealant</b> Bostik® Seal N Flex-1™, Sikaflex® AT Facade, Sikaflex® MS or similar.</p>
	<p><b>65 x 2.87mm 'D' head nail or 65 x 2.87 RounDrive nail</b> (ring shank hot dipped galvanised/stainless steel) For fixing Stria™ Cladding.</p>
	<p><b>75 x 3.06mm 'D' head nail or 75 x 3.15 RounDrive nail</b> (hot dipped galvanised or ring shank stainless steel) For fixing Stria™ Cladding.</p>
	<p><b>40 x 2.8mm or longer Hardie™ Flex nail</b> For fixing timber cavity battens and aluminium flashings.</p>
	<p><b>Exterior grade filler</b> CRC® ADOS® Builders Fill or similar two part filler to fill over nail holes</p>

# 2 Application and Scope

## 2.1 Application

Stria™ Cladding can be fixed to either timber or lightweight steel framed external walls.

For fixing to a steel frame. Ask James Hardie on 0800 808 868 for specific requirements. Or refer to the Steel Frame Technical Supplement by James Hardie about the installation of Stria™ Cladding to steel frame.

### Specifiers

If you are a specifier or other responsible party for a project ensure that the information in this document is appropriate for the application you are planning and that you undertake specific design and detailing for areas which fall outside the scope of these specifications.

### Installers

If you are an installer ensure that you follow the design, moisture management principles, associated figures and material selection provided by the designer and this Technical Specification. All of the details provided in this document must be read in conjunction with the project specification.

### Make sure your information is up to date

When specifying or installing products from James Hardie, ensure that you have the current manual. Additional installation information, warranties and warnings are available at [www.jameshardie.co.nz](http://www.jameshardie.co.nz) or Ask James Hardie™ on 0800 808 868.

## 2.2 Scope

This specification covers the installation of Stria™ Cladding within the following scope:

- The Stria™ Cladding must be installed vertically.
- An external wall structure that complies with the NZBC for an existing building or new building where the designer and/or installer has established that the external wall frame is suitable for the cladding installation.
- In all wind zones up to a design wind pressure of 3.2kPa (ULS) up to 25m of building height. In wind zones greater than Very High (VH), a rigid air barrier must be used.

## 2.3 Details

Various typical Stria™ Cladding construction details are provided within this document. These details are available in dwg, dxf, jpg and pdf file format and can be downloaded from our website at [www.jameshardie.co.nz](http://www.jameshardie.co.nz).

All dimensions shown are in millimetres unless noted otherwise.

## 2.4 Specific Design

For use of Stria™ Cladding on a specific design project that is outside the scope of this literature, the designer, architect or engineer must ensure that applicable clauses of the NZBC have been considered and a specific design has been undertaken.

# 3 Compliance

## 3.1 Compliance

Stria™ Cladding installed vertically in accordance with this specification has been tested to demonstrate compliance with clauses E2, B1, B2 and F2 of the NZBC.

When installed in accordance with the conditions of CodeMark number GM-CM30109 Stria™ Cladding complies with all relevant requirements of the NZBC. Please refer to [www.building.govt.nz](http://www.building.govt.nz) for a copy of the certificate.

Stria™ Cladding Vertical Installation has a BRANZ Appraisal number 1225 (2022) to demonstrate compliance with the requirements of the NZBC. Please refer to our website [www.jameshardie.co.nz](http://www.jameshardie.co.nz) for a copy of the BRANZ appraisal.

# 4 Design

## 4.1 Responsibility

The specifier or other party responsible for the project must ensure that the information and details in this specification are appropriate for the intended application and that additional detailing is performed for specific design or any areas that fall outside the scope of this technical specification. For applications outside the scope of this literature and details, which are not provided herein, the architect, designer or engineer must undertake specific design and it should be ensured that the intent of their design meets the requirements of the NZBC.

All New Zealand Standards referenced in this document are current editions and must be complied with.

James Hardie conducts stringent quality checks to ensure that any product manufactured falls within our quality spectrum. It is the responsibility of the builder to ensure that the product meets aesthetic requirements before installation. James Hardie will not be responsible for rectifying obvious aesthetic surface variations following installation.

## 4.2 Site and Foundation

The site on which the building is situated must comply with the NZBC Acceptable Solution E1/AS1 'Surface Water'. Foundation design must comply with the requirements of NZS 3604 'Timber framed Buildings' or be as per specific engineering design. The grade of adjacent finished ground must slope away from the building to avoid any possibility of water accumulation in accordance with the NZBC requirements.

## 4.3 Clearances

The clearance between the bottom edge of the cladding and paved/unpaved ground must comply with section 9.1.3 of E2/AS1. The finished floor level must also comply with these requirements. These clearances must be maintained throughout the life of the building.

Stria™ Cladding must overhang the bottom plate by a minimum of 50mm, as required by E2/AS1.



Stria™ Cladding must maintain a minimum clearance of 100mm from paved ground, and 175mm from unpaved ground.

On roofs and decks, the minimum clearance must be 50mm.

Do not install external cladding such that it may remain in contact with water or ground, refer to Figure 3.

## 4.4 Moisture Management

It is the responsibility of the specifier to identify moisture related risks associated with any particular building design.

Wall construction design must effectively manage moisture, considering both interior and exterior environments of the building, particularly in buildings that have a higher risk of wind driven rain penetration. The building should also be ventilated sufficiently to control moisture accumulation due to condensation, especially in artificially cooled/heated buildings.

Walls must include those provisions as required by the NZBC Acceptable Solution Clause E2/AS1. In addition, all wall openings, penetrations, junctions, connections, window sills, heads and jambs must incorporate appropriate flashings for waterproofing. The other materials, components and installation methods used to manage moisture in external walls, must comply with the requirements of relevant standards and the NZBC. For further guidance on designing for weathertightness, refer to BRANZ Ltd. and the Ministry of Business, Innovation and Employment (MBIE) updates on the following websites respectively, [www.branz.co.nz](http://www.branz.co.nz) and [www.building.govt.nz](http://www.building.govt.nz).

In addition, the following issues must also be considered:

- Sealant must be applied where detailed in this literature
- For buildings up to 10m high, a drained horizontal joint must be provided at every two floors as minimum. For buildings more than 10m high a drained horizontal joint must be provided at each floor to accommodate the inter-story deflections.
- The installation of smoke chimneys, pipe penetrations and other fixtures etc. must not track moisture into the wall or restrict the drainage of moisture to the exterior.

## 4.5 Structure

### 4.5.1 Timber Framing

Timber framed buildings must either be in accordance with NZS 3604 (Timber-framed buildings) or designed as per specific engineering design.

For timber frame walls longer than 12m, it is best practice to allow for construction joints to accommodate movements generated due to timber shrinkage or deflections generated by loadings etc.

### 4.5.2 Dimensions

A 90 x 45mm minimum framing size is required.

### 4.5.3 Structural Grade

Timber grade used must be in accordance with timber grades specified in NZS 3604.

### 4.5.4 Durability

The external framing timber must be treated to a minimum H1.2 treatment. Higher treatment levels may be used, but check for the compatibility of treatment chemicals with other materials. Refer to the NZBC Acceptable Solution B2/AS1 Durability for further information about the durability requirements.

For timber treatment and allowable moisture content information refer to NZS 3602 (Timber and Wood-Based Products for use in Buildings) and NZS 3640 (Chemical Preservation of Round Sawn Timber) for minimum timber treatment selection and treatment requirements.

Also refer to the framing manufacturer's literature for further guidance on timber selection. Framing must be protected from moisture at the site in accordance with the framing manufacturer's recommendations.

## 4.6 Wind Pressures

Stria™ Cladding is suitable for use in wind zones up to and including EH as defined in NZS 3604.

Stria™ Cladding is also suitable in specific design projects up to design wind pressures of 3.25kPa ULS.

## 4.7 Structural Bracing

Stria™ Cladding installed as per this specification cannot be used to achieve structural bracing. However, bracing can be achieved by using a RAB™ Board/HomeRAB™ Pre-Cladding installed direct to framing instead of a flexible underlay or by using the Villaboard™ Lining bracing system on the internal face of the wall. Refer to the Bracing Design Manual by James Hardie for further information.

## 4.8 Energy Efficiency

External walls constructed as per this technical specification, using Stria™ Cladding must use suitable bulk insulation to meet the minimum thermal insulation requirements as per Clause H1/AS1 'Energy Efficiency' of the NZBC.

## 4.9 Fire Rated Walls

Stria™ Cladding when fixed over timber cavity battens to external walls can achieve fire ratings up to 60/60/60 to comply with Clause C of the NZBC, when the walls are constructed in accordance with the current Fire and Acoustic Design Manual by James Hardie.

## 4.10 Control of External Fire Spread

Stria™ Cladding material is classified as 'Type-A' as per Table C1.3 when tested to the requirements of Appendix C7.1.1 (b) of C/AS2 of the NZBC and is suitable for use where 'Non-Combustible Material' or 'Limited Combustibility Material' is required for use in buildings located anywhere in relation to the relevant boundary for building within the scope of C/AS1 or C/AS2.

- A drained horizontal flashing break must be installed at intervals of no greater than 3.5m vertical height where the upper floors contain sleeping uses or other property.
- On buildings greater than 10m in height a RAB™ Board must be used.

## 4.11 Durability

Clause B2 Durability of the NZBC.

Stria™ Cladding is resistant to moisture induced deterioration (rotting) and meets the requirements of the following tests in accordance with the AS/NZS 2908.2:

- Heat Rain (Clause 6.5)
- Water Permeability (Clause 8.2.2)
- Warm Water (Clause 8.2.4)
- Soak Dry (Clause 8.2.5)

## 4.12 Alpine Regions

In regions subject to freeze/thaw conditions, Stria™ Cladding, HomeRAB™ Pre-Cladding/RAB™ Board must not be in direct contact with snow or ice build up for extended periods, e.g. external walls in alpine regions must be protected where snowdrifts over winter are expected.

These products meet the requirements of the AS/NZS 2908.2 Clause 8.2.3.

# 5 Safe Working Practices

## **WARNING - DO NOT BREATHE DUST AND CUT ONLY IN WELL VENTILATED AREA**

**Hardie™ fibre cement products contain sand, a source of respirable crystalline silica may cause cancer if dust from product is inhaled. Causes damage to lungs and respiratory system through prolonged or repeated inhalation of dust from product.**

Intact fibre cement products are not expected to result in any adverse toxic effects. The hazard associated with fibre cement arises from the respirable crystalline silica present in dust generated by activities such as cutting, rebating, drilling, routing, sawing, crushing, or otherwise abrading fibre cement, and when cleaning up, disposing of or moving dust.

When doing any of these activities in a manner that generates dust, follow James Hardie instructions and best practices to reduce or limit the release of dust.

If using a dust mask or respirator, use an AS/NZS1716 P1 filter and refer to Australian/New Zealand Standard 1715:2009 Selection, Use and Maintenance of Respiratory Protective Equipment for more extensive guidance and more options for selecting respirators for workplaces. For further information, refer to our installation instructions and Safety Data Sheets available at [www.jameshardie.co.nz](http://www.jameshardie.co.nz).

**FAILURE TO ADHERE TO OUR WARNINGS, SAFETY DATA SHEETS, AND INSTALLATION INSTRUCTIONS MAY LEAD TO SERIOUS PERSONAL INJURY OR DEATH.**

### **Crystalline Silica is**

- Commonly known as sand or quartz
- Found in many building products e.g. concrete, bricks, grout, wallboard, ceramic tiles, and all fibre cement materials

### **Why is Crystalline Silica a health hazard?**

- Silica can be breathed deep into the lungs when present in the air as a very fine (respirable) dust
- Exposure to silica dust without taking the appropriate safety measures to minimise the amount being breathed in, can lead to a potentially fatal lung disease – silicosis – and has also been linked with other diseases including cancer. Some studies suggest that smoking may increase these risks
- The most hazardous dust is the dust you cannot see!

### **When is Crystalline Silica a health hazard?**

- It's dangerous to health if safety protocols to control dust are not followed when cutting, drilling or rebating a product containing crystalline silica and when cleaning up
- Products containing silica are harmless if intact (e.g. an un-cut sheet of wall board)

## **Avoid breathing in crystalline silica dust**

### **Safe working practices**

- ✗ NEVER use a power saw indoors or in a poorly ventilated area
- ✗ NEVER dry sweep
- ✓ ALWAYS use M Class or higher vacuum or damp down dust before sweeping up
- ✗ NEVER use grinders
- ✓ ALWAYS use a dust reducing circular saw equipped with a sawblade specifically designed to minimise dust creation when cutting fibre cement – preferably a sawblade that carries the Hardie™ Blade name or one with at least equivalent performance – connected to an M Class or higher vacuum
- ✓ Before cutting warn others in the area to avoid dust
- ✓ ALWAYS follow tool manufacturers' safety recommendations
- ✓ ALWAYS expose only the minimum required depth of blade for the thickness of fibre cement to be cut
- ✓ ALWAYS wear a properly-fitted, approved dust mask or respirator P1 or higher in accordance with applicable government regulations and manufacturer instructions
- ✓ Consider rotating personnel across cutting tasks to further limit respirable silica exposures.

### **When cutting Stria™ Cladding:**

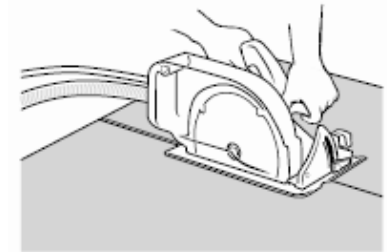
- ✓ Work outdoors only
- ✓ Make sure you work in a well ventilated area
- ✓ Position cutting station so wind will blow dust away from yourself and others in the working area
- ✓ Rotate employees across cutting task over duration of shift
- ✓ Cut products with a Hardie™ Blade Saw Blade (or equivalent) and a dust reducing circular saw connected to a M Class or higher vacuum
- ✓ When sawing, sanding, rebating, drilling or machining fibre cement products, always:
  - Wear your P1 or higher (correctly fitted in accordance with manufacturers' instructions), ask others to do the same.
  - Keep persons on site at least 2 metres and as far as practicable away from the cutting station while the saw is in operation
  - If you are not clean shaven, then use a powered air respirator with a loose fitting head top
  - Wear safety glasses
  - Wear hearing protection
- ✓ Make sure you clean up BUT never dry sweep. Always hose down with water/wet wipe or use an M Class or higher vacuum

**If concern still exists about exposure levels or you do not comply with the above practices, you should always consult a qualified industrial hygienist or contact James Hardie for further information.**

## Working Instructions

### Hardie™ Blade Saw Blade

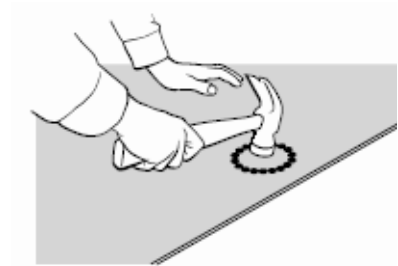
The Hardie™ Blade Saw Blade used with a dust-reducing saw is ideal for fast, clean cutting of Hardie™ fibre cement products. A dust-reducing saw uses a dust collector connected to a M Class or higher vacuum. When sawing, clamp a straight edge to the sheet as a guide and run the saw base plate along the straight edge when making the cut.



### Hole-Forming

#### For smooth clean cut circular holes:

- Mark the centre of the hole on the sheet
- Pre-drill a 'pilot' hole
- Using the pilot hole as a guide, cut the hole to the appropriate diameter with a hole saw fitted to a heavy duty electric drill



#### For irregular holes:

- Small rectangular or circular holes can be cut by drilling a series of small holes around the perimeter of the hole then tapping out the waste piece from the sheet face
- Tap carefully to avoid damage to sheets, ensuring that the sheet edges are properly supported

## 5.1 Storage and Delivery

Keeping products and people safe

### Off loading

- ✓ Hardie™ fibre cement products should be off-loaded carefully by hand or by forklift
- ✓ Hardie™ fibre cement products should not be rolled or dumped off a truck during the delivery to the jobsite

### Storage

Hardie™ fibre cement products should be stored:

- ✓ In their original packaging
- ✓ Under cover where possible or otherwise protected with a waterproof covering to keep products dry
- ✓ Off the ground – either on a pallet or adequately supported on timber or other spacers
- ✓ Flat so as to minimise bending

Hardie™ fibre cement products must not be stored:

- ✗ Directly on the ground
- ✗ In the open air exposed to the elements

**James Hardie is not responsible for damage due to improper storage and handling.**

## 5.2 Tips for Safe and Easy Handling of Stria™ Cladding

### Weatherboard products

- ✗ Do not lift planked products flat and in the middle
- ✓ Carry the products on the edge
- ✓ If only one person is carrying the product, hold it in the middle and spread arms apart to better support the product
- ✓ If two people are carrying the plank, hold it near each end and on edge
- ✓ Exercise care when handling planked products to avoid damaging the edges/corners

# 6 Installation

Stria™ Cladding is installed vertically using the cavity construction method as per the details and information published in this manual. Stria™ Cladding panels are 325mm or 405mm wide and are installed with a 25mm nominal lap over the panel below. Considering the installation and machining variations the effective cover for Stria™ Cladding can vary 300 to 302mm or 380 to 382mm respectively.

Stria™ Cladding must be kept under cover whilst in storage or at sites and they must be dry at the time of their installation. All site-cut board edges must be sealed with Dulux® 1 Step, Resene® Quick Dry, Taubmans® Underproof Acrylic Primer Undercoat or a similar sealer compatible with the finish coat before installation.

Stria™ Cladding must be fully supported and fixed through Hardie™ horizontal cavity battens. Ensure that cladding is hard against the battens to avoid drumminess before fixing.

This technical specification only covers the vertical installation of Stria™ Cladding. For horizontal installation refer to the Stria™ Cladding timber cavity batten technical specification.

## 6.1 Fastener

### 6.1.1 Fastener – Size and Layout

Stria™ Cladding must be fixed vertically to framing using fixings as specified in Tables 4 and 5 and follow the edge distance required for nails as shown in the details.

When using rigid air barrier like HomeRAB™ Pre-Cladding or RAB™ Board, the cladding fixing nails must be increased in length equal to the thickness of the rigid air barrier.

**Table 4****Stria Cladding 405mm**

Cavity Construction	Wind Zone	Fixing	Fastener Type
Over flexible underlay	Up to and including VH wind zone	Fix a nail at 100mm from top edge and 100mm from bottom edge/per board/per nog/plate. Refer to Figure 5.	65 x 2.87mm D head or 65 x 2.87mm RounDrive ring shank nails or 75 x 3.15mm Hardie™ Flex nails
Over HomeRAB™ Pre-Cladding	Up to and including VH wind zone	Fix a nail at 100mm from top edge and 100mm from bottom edge/per board/per nog/plate. Refer to Figure 5.	75 x 3.06mm D head or 75 x 3.15mm RounDrive ring shank nails or 75 x 3.15mm Hardie™ Flex nails
Over RAB™ Board	Up to and including EH wind zone and SED projects	Fix a nail at 100mm from top edge and 100mm from bottom edge/per board/per nog/plate. Refer to Figure 5.	75 x 3.06mm D head nails or 75 x 3.15mm RounDrive ring shank nails

**Table 5****Stria Cladding 325mm**

Cavity Construction	Wind Zone	Fixing	Fastener Type
Over flexible underlay	Up to and including VH wind zone	Fix a nail at 80mm from top edge and 80mm from bottom edge/per board/per nog/plate. Refer to Figure 5.	65 x 2.87mm D head or 65 x 2.87mm RounDrive ring shank nails or 75 x 3.15mm Hardie™ Flex nails
Over HomeRAB™ Pre-Cladding	Up to and including VH wind zone	Fix a nail at 80mm from top edge and 80mm from bottom edge/per board/per nog/plate. Refer to Figure 5.	75 x 3.06mm D head or 75 x 3.15mm RounDrive ring shank nails or 75 x 3.15mm Hardie™ Flex nails
Over RAB™ Board	Up to and including EH wind zone and SED projects	Fix a nail at 80mm from top edge and 80mm from bottom edge/per board/per nog/plate. Refer to Figure 5.	75 x 3.06mm D head nails or 75 x 3.15mm RounDrive ring shank nails

- When fixing the panels using nail guns, refer to the nail gun manufacturer for information about nails and the type of nail gun to be used.
- The loose 75 x 3.15mm Hardie™ Flex nail is only suitable for use up to VH wind zone
- Stud width of 70mm min required when using a vertical joint flashing. Refer Figure 8.
- D head nails - finish nails 2mm below panel surface.
- RounDrive nails /Hardie™ Flex nails - finish nails flush with panel surface.

For other fixing options Ask James Hardie on **0800 808 868**.

### 6.1.2 Fastener Durability

Fasteners must meet the minimum durability requirements of the NZBC. NZS 3604 specifies the requirements for fixing materials to be used in relation to exposure conditions and are summarised in Table 6. Fasteners must be fully compatible with the other materials that they are to be in contact with, to ensure the durability of the complete assembly.

**Table 6 Exposure conditions and nail selection prescribed by NZS 3604**

Zone	Application	
D (Sea Spray) *	General	Stainless Steel 304/316
	Fire	
	Bracing	
C and B and Geothermal hot spots	General	Hot Dip Galvanised
	Fire	
	Bracing	

\*Zone C areas where local knowledge dictates that increased durability is required, appropriate selection shall be made. Microclimate conditions as detailed in NZS 3604, Paragraph 4.2.4 require SED.

\*\*Hot dip galvanised must comply with AS/NZS 4680

Also refer to the NZBC Acceptable Solution E2/AS1 Table 20 and 21 for information regarding the selection of suitable fixing materials and their compatibility with other materials.

## 6.2 Framing

Stria™ Cladding can be fixed either to a timber-frame or steel-frame.

For fixing to a steel frame. Ask James Hardie on **0800 808 868** for specific requirements.

### 6.2.1 Special Framing Requirements

The following are special framing requirements for both timber and steel framing:

- Double studs are required at internal corners, refer to Figure 9
- Extra packers may be required at external corners

### 6.2.2 Tolerances

In order to achieve the required performance and an acceptable wall finish, it is imperative that framing is straight and true. Framing tolerances must comply with Table 2.1 of NZS 3604 and the manufacturer's specifications. All framing shall be made flush.

### 6.2.3 Frame Construction

Use of timber framing must be in accordance with NZS 3604 and the framing manufacturer's specifications. The framing must be rigid and must not rely on the cladding for stability. Timber framing sizes and its set-out must comply with NZS 3604 and as specified in this technical specification.

The following framing is required:

- Studs must be provided at 600mm centres maximum
- Nogs must be provided at 600mm centres maximum
- An extra stud is required in internal corners
- For specific design projects exposed to wind speeds higher than 55m/sec, the stud size and spacing must be as per the project specific engineering design requirements
- The nog spacing must be closed to 400mm centres for EH and SED wind zones.

In case of gable end trusses sitting on top plates of the external wall frame, the frame size must be in accordance with truss design and specification supplied by the frame and truss manufacturer/supplier supported by independent design producer statement.



### 6.3 Flexible Underlay or HomeRAB™ Pre-Cladding

Flexible underlay/rigid air barrier eg. HomeRAB™ Pre-Cladding must be provided as per the requirements of External Moisture Clause E2 of the NZBC. The flexible underlay selected for use must comply with Table 23 of E2/AS1.

The flexible underlay must be fixed in accordance with section 9.1.7 of E2/AS1 and the underlay manufacturer's recommendations.

Walls which are not lined on the inside face e.g. garage walls or gable ends, must include a rigid sheathing or an air barrier behind the cladding which complies with Table 23 of E2/AS1.

HomeRAB™ Pre-Cladding complies with these requirements and is suitable for use in this situation. It must be installed in accordance with HomeRAB™ Pre-Cladding and RAB™ Board Installation Manual.

### 6.4 Intermediate support for flexible underlays

Where studs are at 600mm centres an intermediate means of restraining the flexible underlay and insulation from bulging into the cavity shall be installed. An acceptable method to achieve this is using one of the following options:

- 75mm galvanised mesh; or
- Polypropylene tape at 300mm centres fixed horizontally and drawn taut

No intermediate supports are required:

- When studs are spaced at 400mm centres; or
- When rigid air barriers instead of flexible underlays are used

### 6.5 RAB™ Board

With EH wind zone or for specific design wind zone, a rigid air barrier e.g. RAB™ Board must be used instead of flexible underlay as per E2/AS1 clause 9.1.7.2.

RAB™ Board must also be used in buildings that are higher than 10m.

To achieve temporary weathertightness using HomeRAB™ Pre-Cladding/RAB™ Board, windows/doors need to be temporarily installed. Refer to the HomeRAB™ Pre-Cladding and RAB™ Board installation manual for information regarding its installation.

### 6.6 Flashings

All wall openings, penetrations, intersections, connections, window sills, heads and jambs must be flashed prior to Stria™ Cladding installation. Refer to moisture management requirements in Clause 2.5. The flexible underlay/rigid air barrier must be appropriately incorporated with penetration and junction flashings using flashing tapes. Materials must be lapped in such a way that water tracks down to the exterior on the face of the flexible underlay or rigid air barrier board.

The selected flashing materials must comply with the durability requirements of the NZBC. For information refer to Table 20 of E2/AS1.

When using HomeRAB™ Pre-Cladding/RAB™ Board the entire framing around openings must be protected with a flashing tape. The tape must be finished over the face of the rigid air barrier. Ensure to check the compatibility of flashing tapes and sealants with their manufacturers. Refer to the HomeRAB™ Pre-Cladding and RAB™ Board installation manual for further information.

### 6.7 Cavity Closure/Vent Strip

The Hardie™ uPVC cavity vent strip must be installed at the bottom of all walls and above all openings constructed using the drained and ventilated cavity construction method. It is important that the openings in the cavity closure/vent strip are kept clear and unobstructed to allow free drainage and ventilation of cavities. Hardie™ uPVC vent strip has an opening area of 1000mm<sup>2</sup>/m length.

## 6.8 Cavity Battens

Stria™ Cladding is to be installed on Hardie™ 20mm horizontal cavity battens. The battens provide ventilation and drainage between the frame and the cladding and are considered a “packer” only in this specification.

The Hardie™ 20mm horizontal cavity battens are H3.1 treated in accordance with NZS 3640 (Chemical preservation of rough and sawn timber) to comply with the durability requirements of B2/AS1.

Hardie™ 20mm horizontal cavity battens meet the requirements of E2/AS1 and:

- Are minimum 20mm thick and 45mm wide;
- Fixed horizontally to nogs;
- Fixed vertically to studs at corners and openings;
- Must be fixed by the cladding fixings to the main framing over the flexible underlay. Therefore until claddings are fixed the battens only need to be tacked to framing by 40 x 2.8mm or longer nails at 800mm centres;
- Permit air circulation and water drainage.

## 6.9 Joints

### 6.9.1 Vertical Joint

Stria™ Cladding vertical joint shall be formed using the ship lap edge of the Stria™ Cladding. Ensure that the Stria™ Cladding is securely interlocked before nailing, refer to Figure 5.

### 6.9.2 Horizontal Joint

Stria™ Cladding can run continuously over floor joists without a flashed horizontal joint when **LVL timber floor joists or engineered joist are used**, refer to Figure 20.

When using a solid timber joist, a horizontal joint or a movement joint must be formed at floor joist, refer to Figure 21.

### 6.9.3 Drainage Joint

After every two floors a horizontal drainage joint flashing is required as per E2/AS1, refer to Figure 26.

For buildings higher than 3 storey, from a vertical fire spread safety perspective, a horizontal drainage joint is required at each floor.

### 6.9.4 External Corner

An external box corner flashing is used to fix the external corners, refer to Figure 6. Alternatively a trim external boxed corner can also be formed.

**Note:** All joint mouldings to be fixed at 400mm centres both sides.

### 6.9.5 Internal Corner

An internal corner flashing is to be used to form an internal corner joint, refer to Figure 9. An extra stud is required in internal corners.

**Note:** All joint mouldings to be fixed at 400mm centres both sides.

## 6.10 Junctions and Penetrations

Refer to Clause 4.4 of this specification for moisture management requirements. All windows and doors must be detailed as per the requirements of this specification. For an example of window details for Stria™ Cladding which meet the performance requirements of E2 External Moisture, an approved document of the NZBC, refer to Figures 12 to 19.

# 7 Finishes

## 7.1 Preparation

The D head nail must be finished 2mm below the cladding surface. The nail holes must be filled with an exterior grade two part builders fill, ie. CRC® ADOS® Builders Fill or similar two part external grade filler.

The RounDrive nail/Hardie™ Flex nail heads must finish flush with cladding surface.

## 7.2 Painting

Stria™ Cladding is pre-primed and is suitable for site applied acrylic paints.

In order to seal cut edges or sanded patches, Dulux® 1 Step, Resene® Quick Dry, Taubmans® Underproof Acrylic Primer Undercoat or a similar product should be applied. The primer should be compatible with the paint to be used.

Painting of Stria™ Cladding is mandatory to meet the durability requirements of the NZBC and 25 year James Hardie product warranty. Stria™ Cladding must be dry and free of any dust or grime before painting. The cladding must be painted within 90 days of installation. There is no restriction on the LRV of paint to be applied on the Stria™ Cladding.

James Hardie recommends a minimum of two coats of exterior grade acrylic paint. Follow the paint manufacturer's recommendations to prepare the surface and to adequately cover and conceal the cladding fixings.

For the best aesthetic results a low sheen paint is recommended.

## 7.3 Flexible Sealant

Sealant used must comply with the relevant requirements of the NZBC. Their application and usage must be in accordance with the manufacturer's instructions. Check with the sealant manufacturer prior to coating over sealant. Some sealant manufacturers do not recommend coating over their product.

# 8 Care and Maintenance

The extent and nature of maintenance required will depend on the geographical location and exposure of the building. It is the responsibility of the specifier to determine normal maintenance requirements to maintain the effectiveness of the cladding.

As a guide, it is recommended that the basic normal maintenance tasks shall include, but not be limited to:

- Washing down exterior surfaces every 6 - 12 months using low pressure water and a brush, and every 3-4 months in extreme coastal conditions or sea spray zones. Do not use a water blaster to wash down the cladding. Refer to your paint manufacturer for washing down requirements.
- Re-coating exterior protective finishes. Always refer to your paint manufacturer for re-coating requirements.
- Regular inspection and repair if necessary of the cladding joints, sealants, nail head fillers
- Cleaning out gutters, down pipes and overflow pipes as required
- Pruning back vegetation which is close to or touching the Stria™ Cladding as well as ensuring the NZBC ground clearance requirements are maintained, especially where gardens are concerned
- The clearance between the bottom edge of the Stria™ Cladding and the finished/unfinished ground must always be maintained.

# 9 Details Section Index

Description	Page
Figure 1: Framing set out	22
Figure 2: Cladding layout	23
Figure 3: Foundation details	24
Figure 4: Enclosed deck	25
Figure 5: Cladding and Hardie™ horizontal batten setout	26
Figure 6: External aluminium box corner	27
Figure 7: External corner with facings	28
Figure 8: External aluminium box corner negative detail	29
Figure 9: Internal aluminium corner	30
Figure 10: Soffit detail	31
Figure 11: Nil soffit detail	32
Figure 12: Window sill	33
Figure 13: Window jamb	34
Figure 14: Window jamb with scriber	35
Figure 15: Window head	36
Figure 16: Window sill with facings	37
Figure 17: Window jamb flashing	38
Figure 18: Window jamb	39
Figure 19: Door sill support	40
Figure 21: Trimline joint flashing at floor level	42
Figure 22: Trimline joint flashing	43
Figure 23: Trimline joint external corner - Option a	44
Figure 24: Trimline joint external corner - Option b	45
Figure 25: Trimline flashing joint internal corner	46
Figure 26: Drained flashing joint at floor level	47
Figure 28: Pipe penetration	49
Figure 29: Apron flashing detail	50
Figure 30: Parapet flashing	51
Figure 31: Roof to wall junction detail	52
Figure 32: Garage head	53
Figure 33: Garage jamb	54
Figure 34: Framing setout building height over 10m	55
Figure 35: Vertical fire separation at floor level over 10m	56

For all meter box details please visit our website at [www.jameshardie.co.nz](http://www.jameshardie.co.nz) or Ask James Hardie on **0800 808 868**.

Figure 1: Framing set out

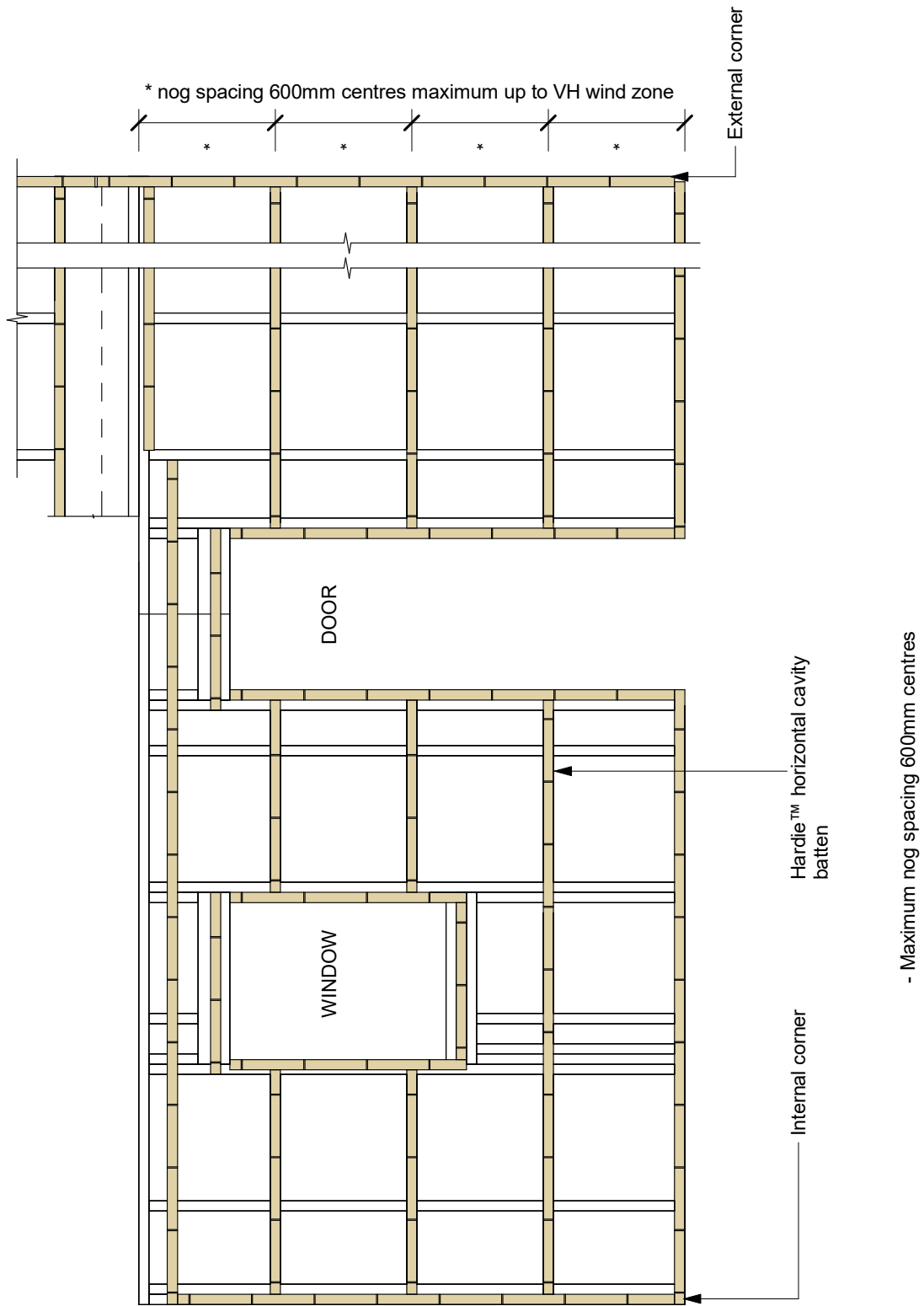
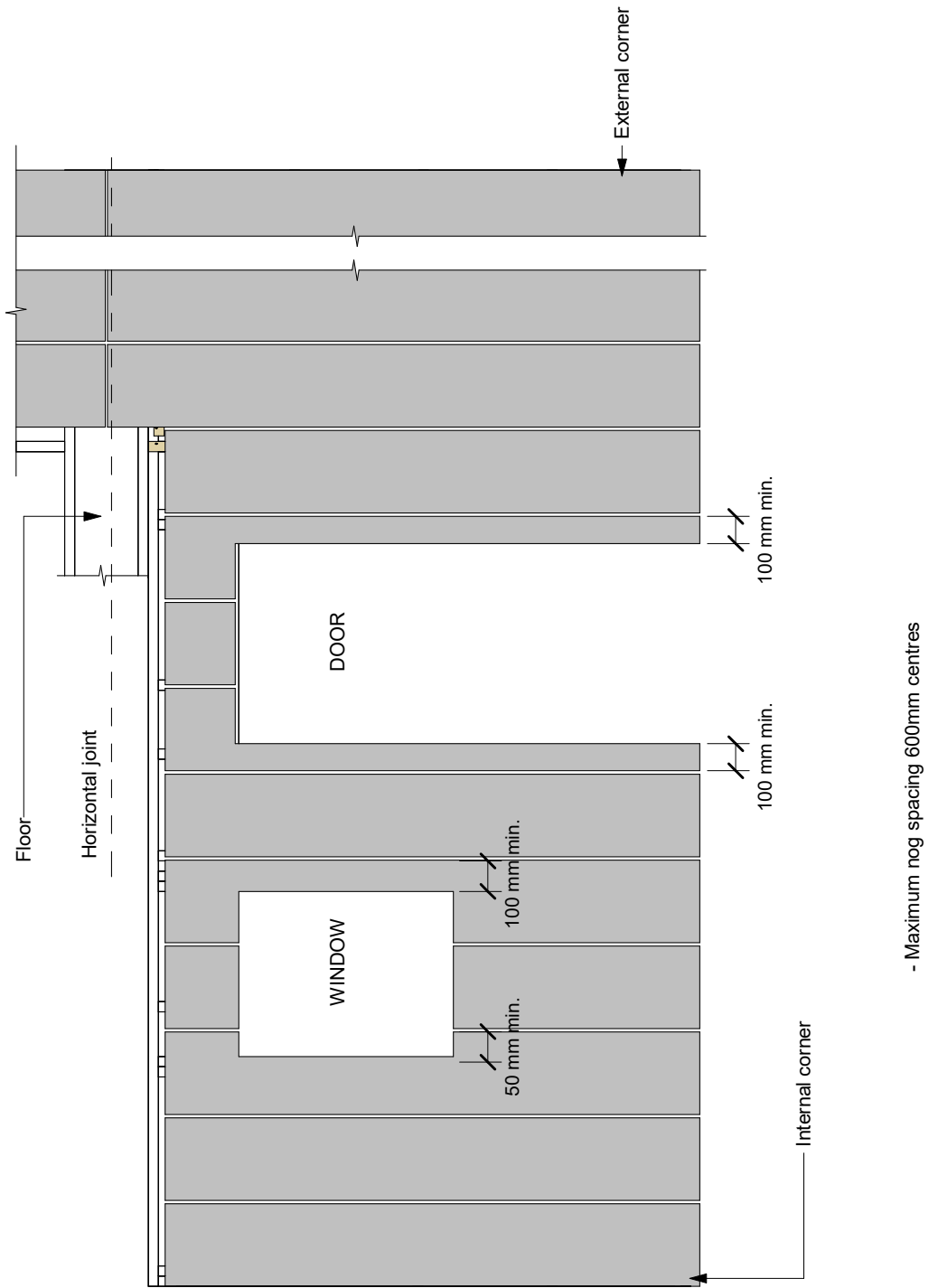
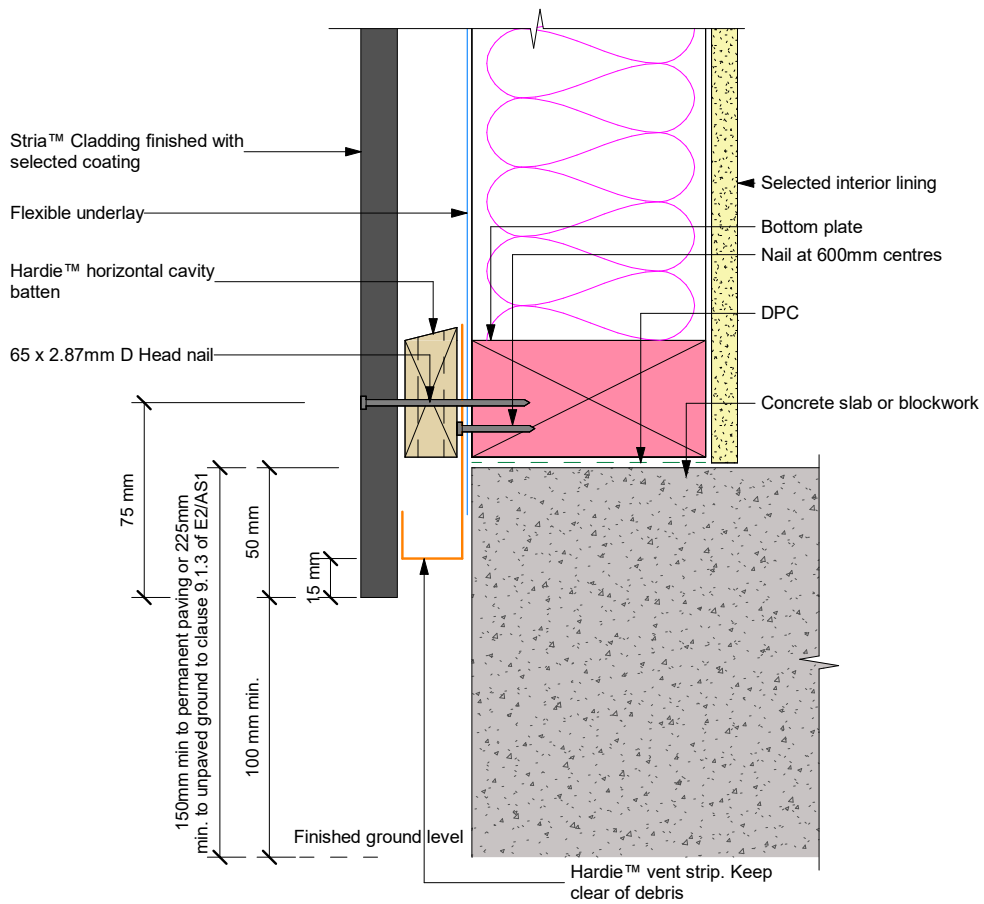


Figure 2: Cladding layout



- Maximum nog spacing 600mm centres

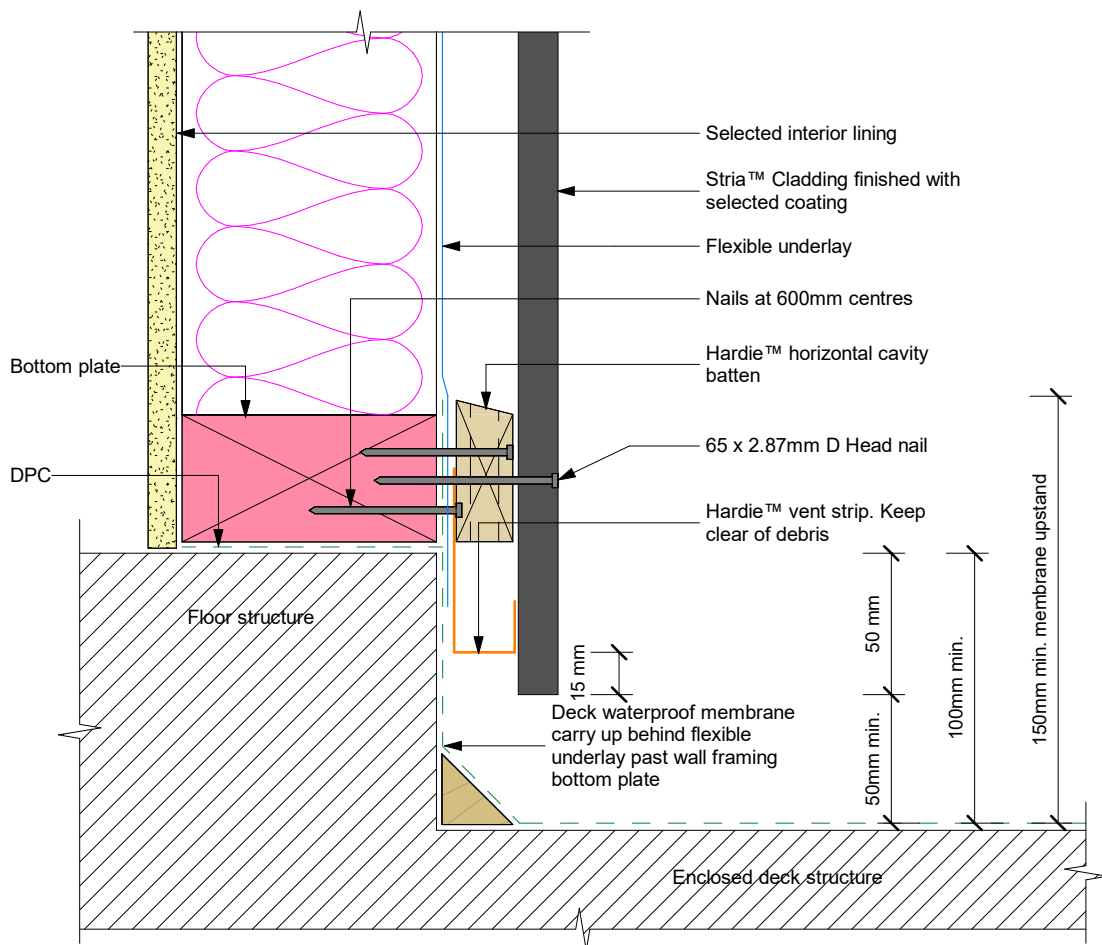
**Figure 3: Foundation details**



Note: Site cut edges to be primed



**Figure 4: Enclosed deck**



**Figure 5: Cladding and Hardie™ horizontal batten setout**

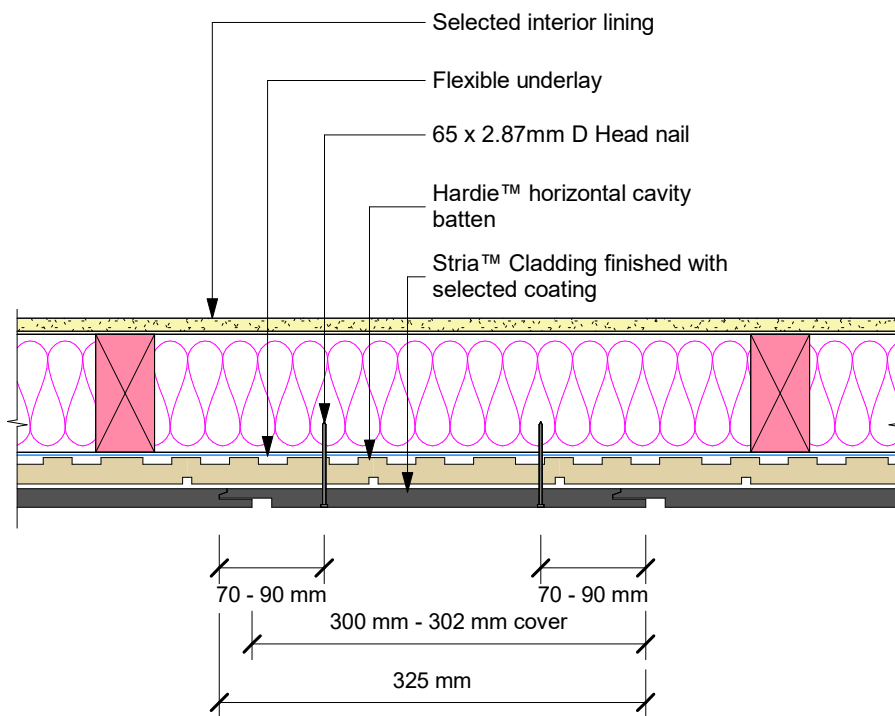
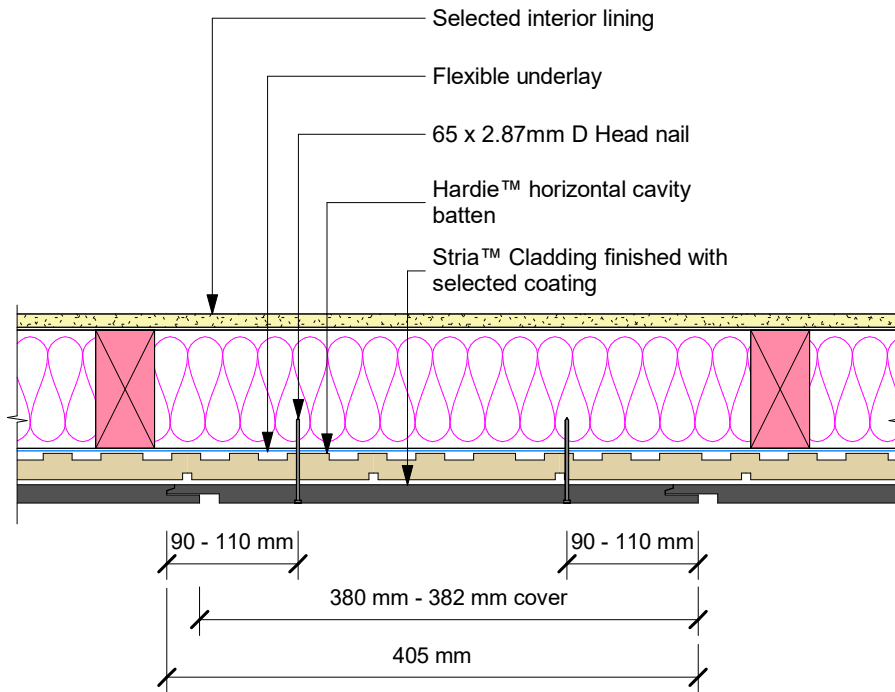
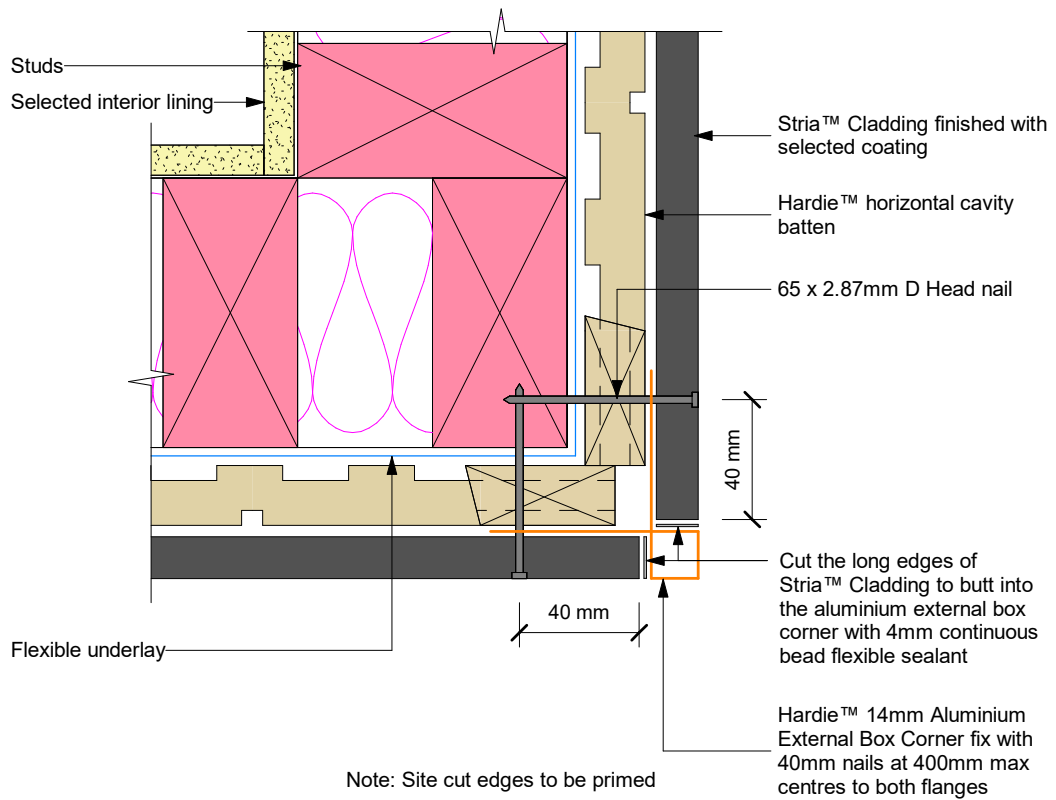


Figure 6: External aluminium box corner

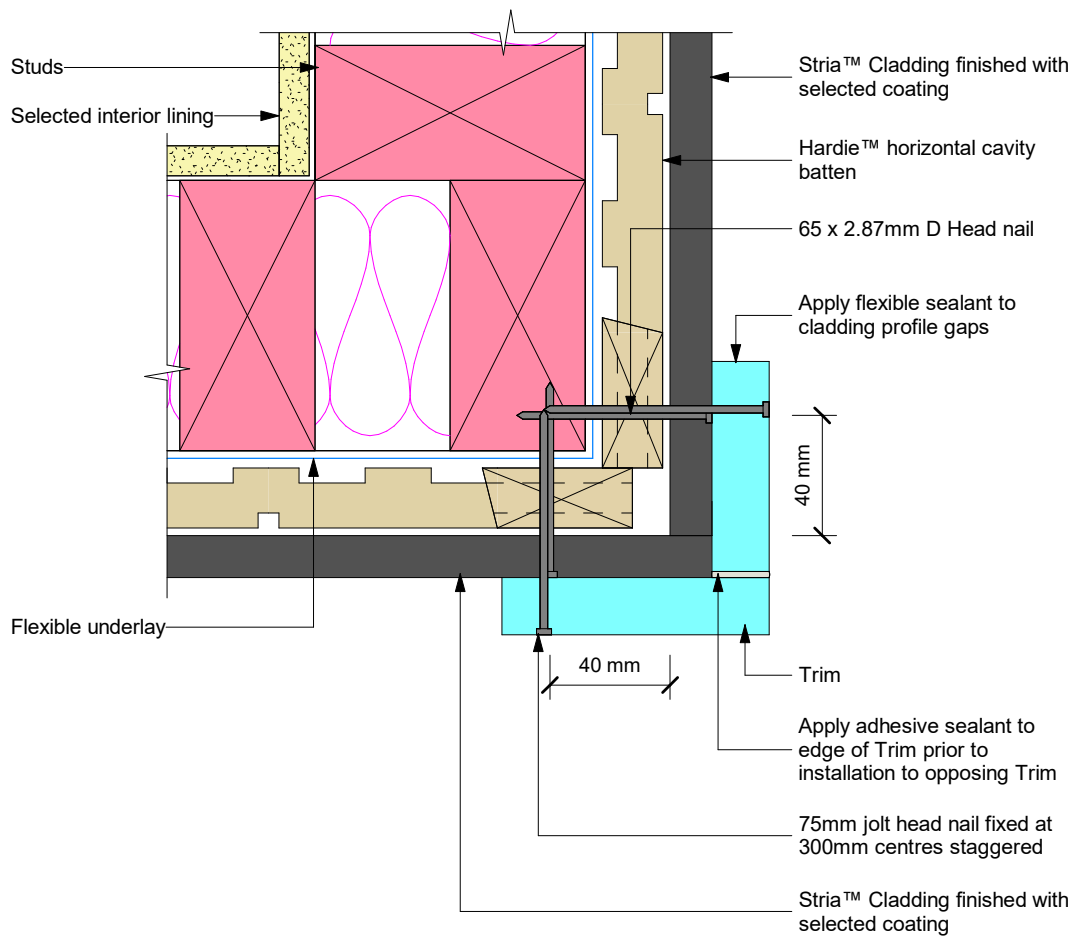
interactive assembly instructions available  
<http://wksp.nz/jh-str-vexc>



Get WORKINGSPEC from Apple App Store/Google Play



**Figure 7: External corner with facings**



Note: Site cut edges to be primed

**Figure 8: External aluminium box corner negative detail**

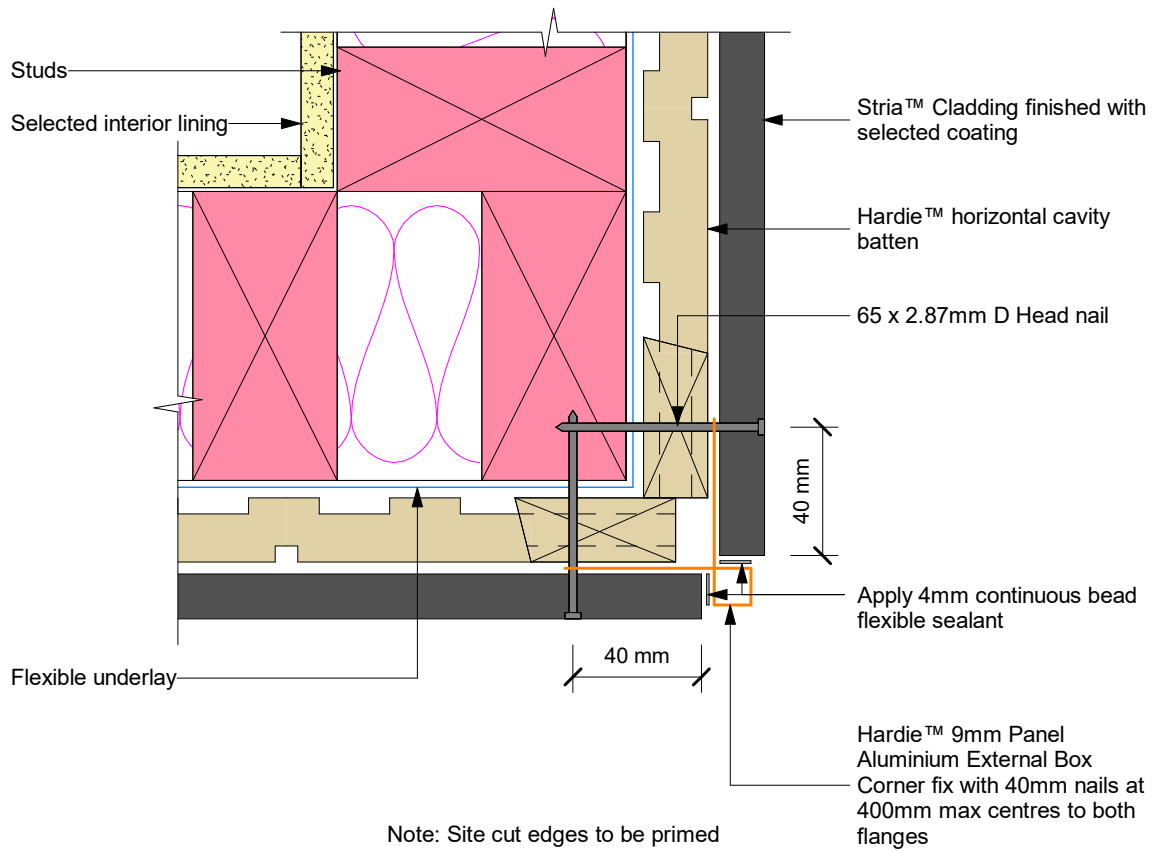


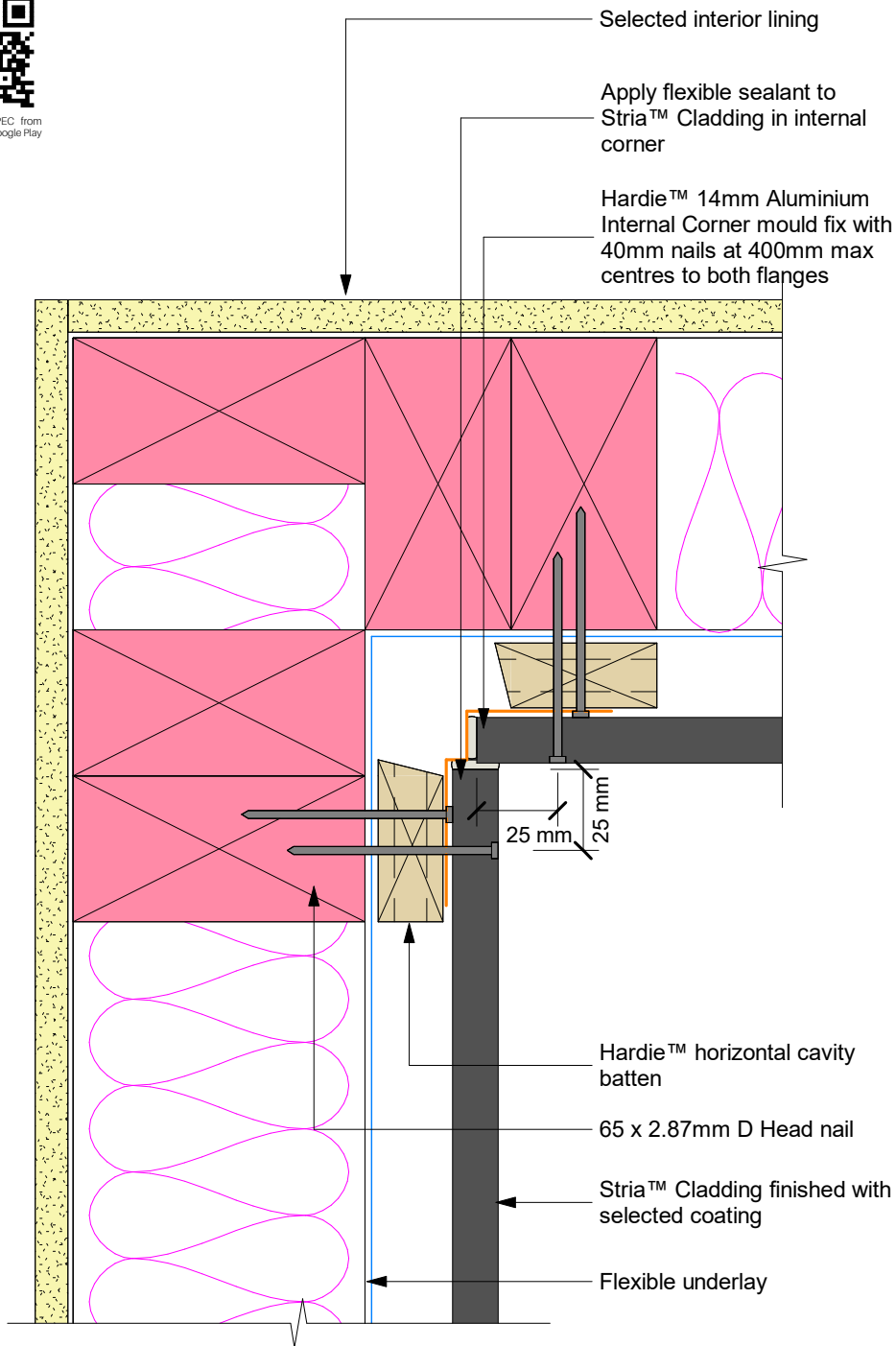
Figure 9: Internal aluminium corner

Interactive assembly  
instructions available

<http://wksp.nz/jh-str-vinc>

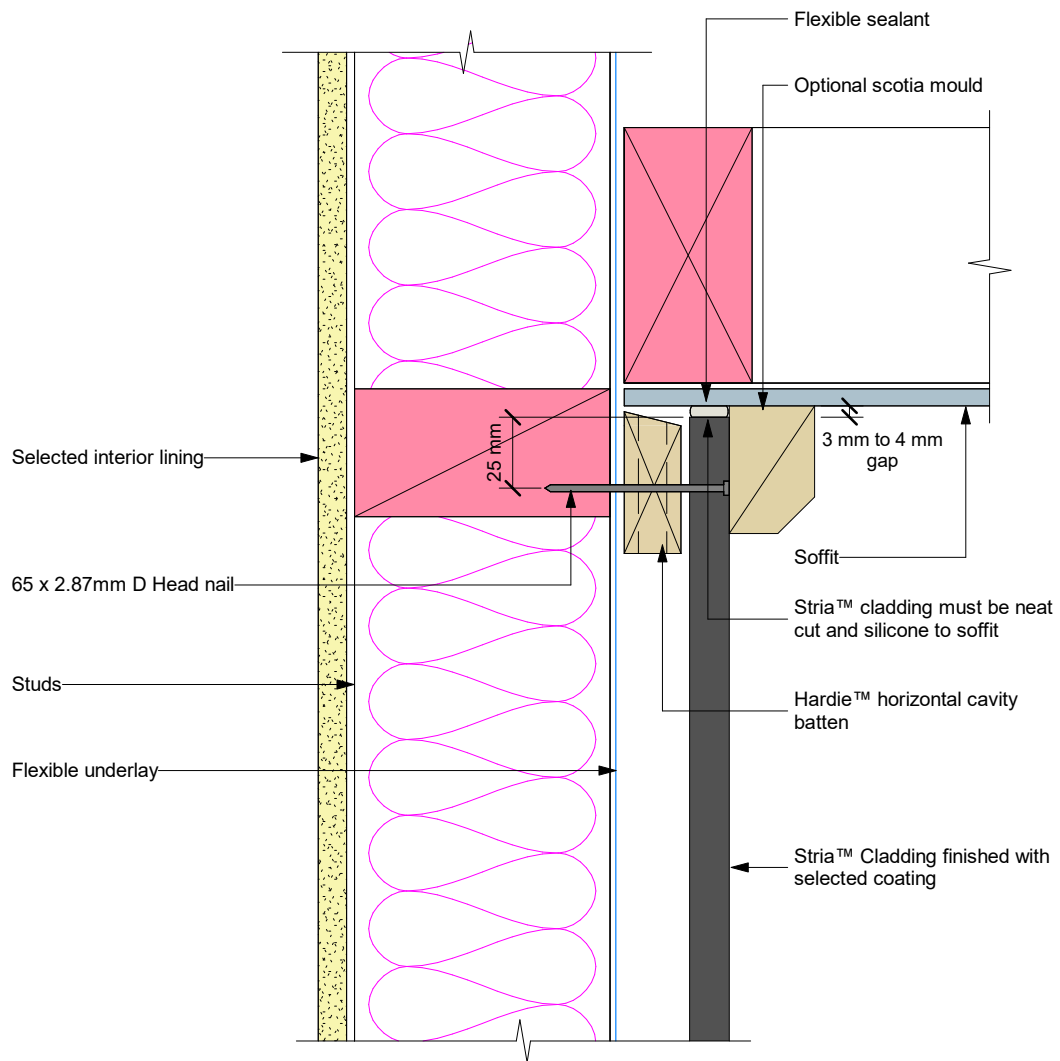


Get WORKINGSPEC from  
Apple App Store/Google Play



Note: Site cut edges to be primed

Figure 10: Soffit detail



Note: Site cut edges to be primed

Figure 11: Nil soffit detail

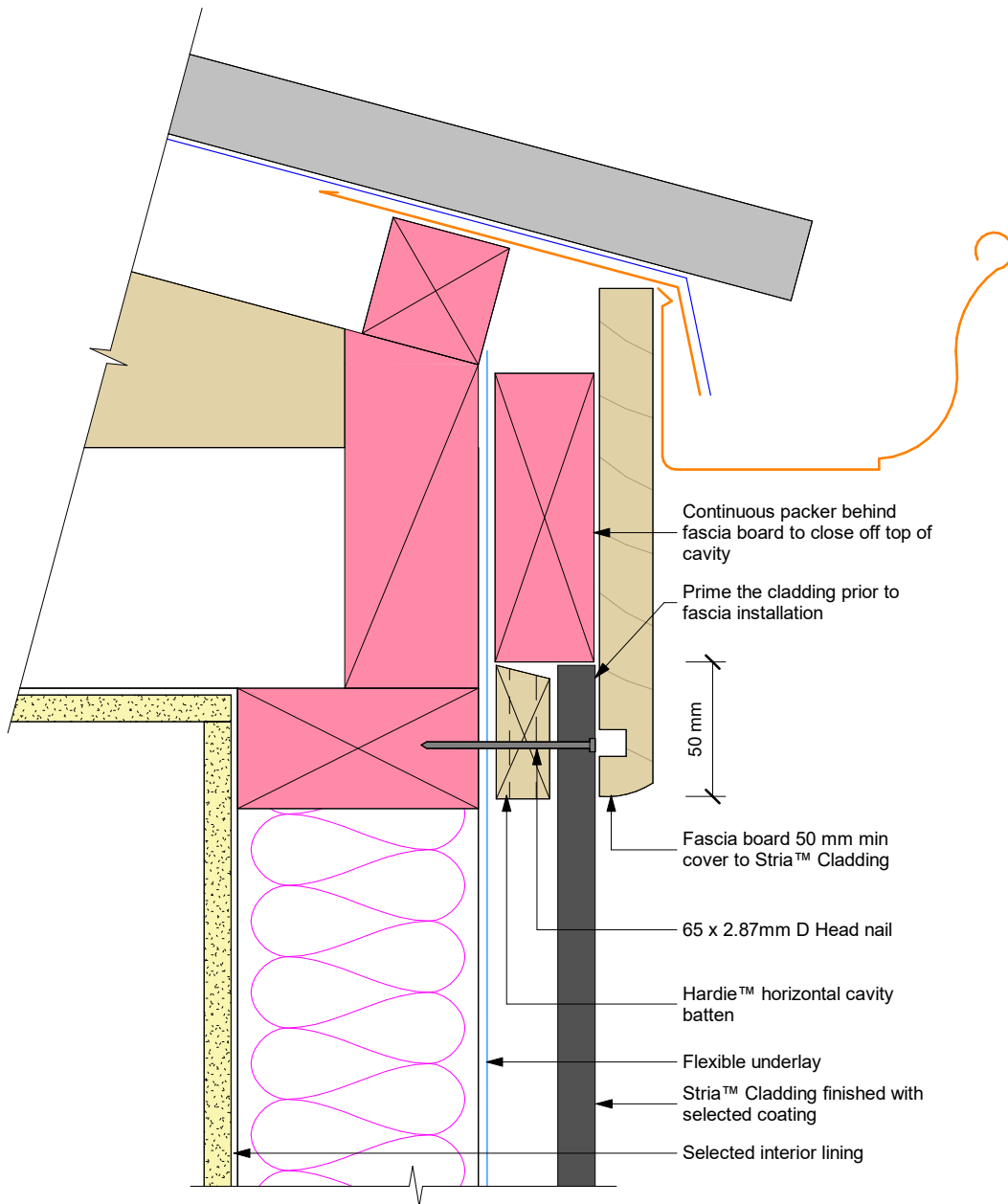
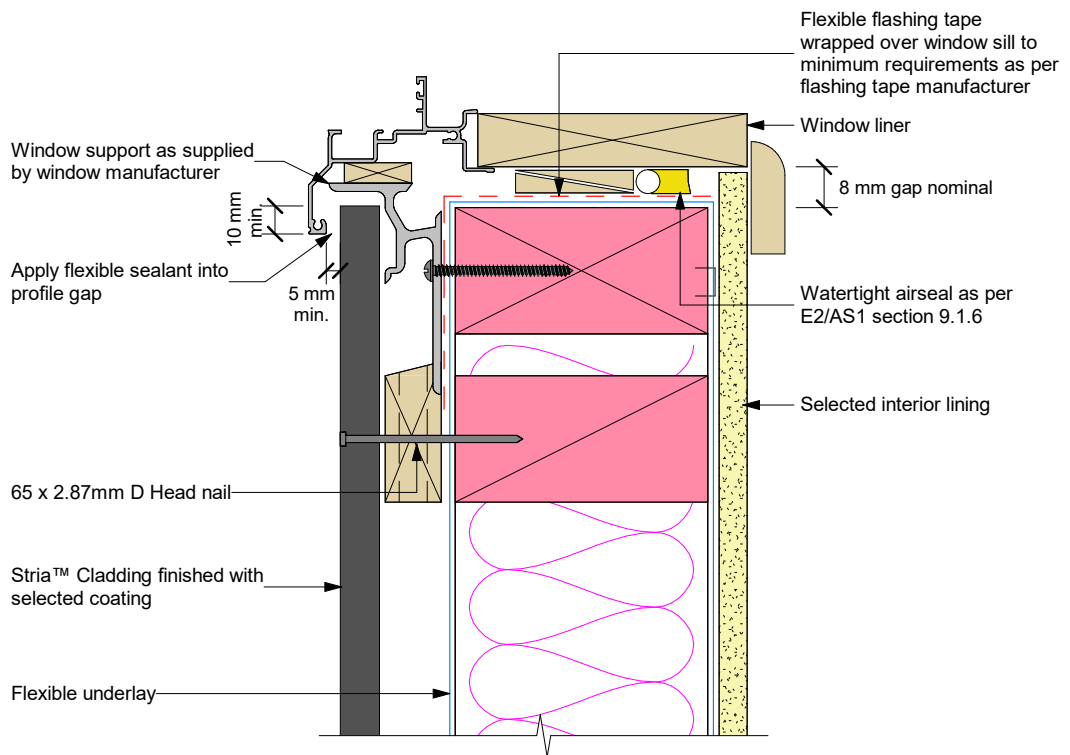




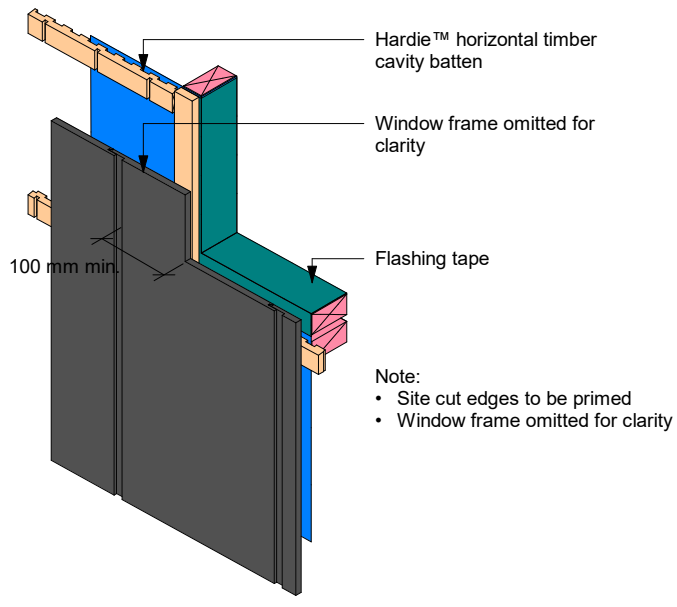
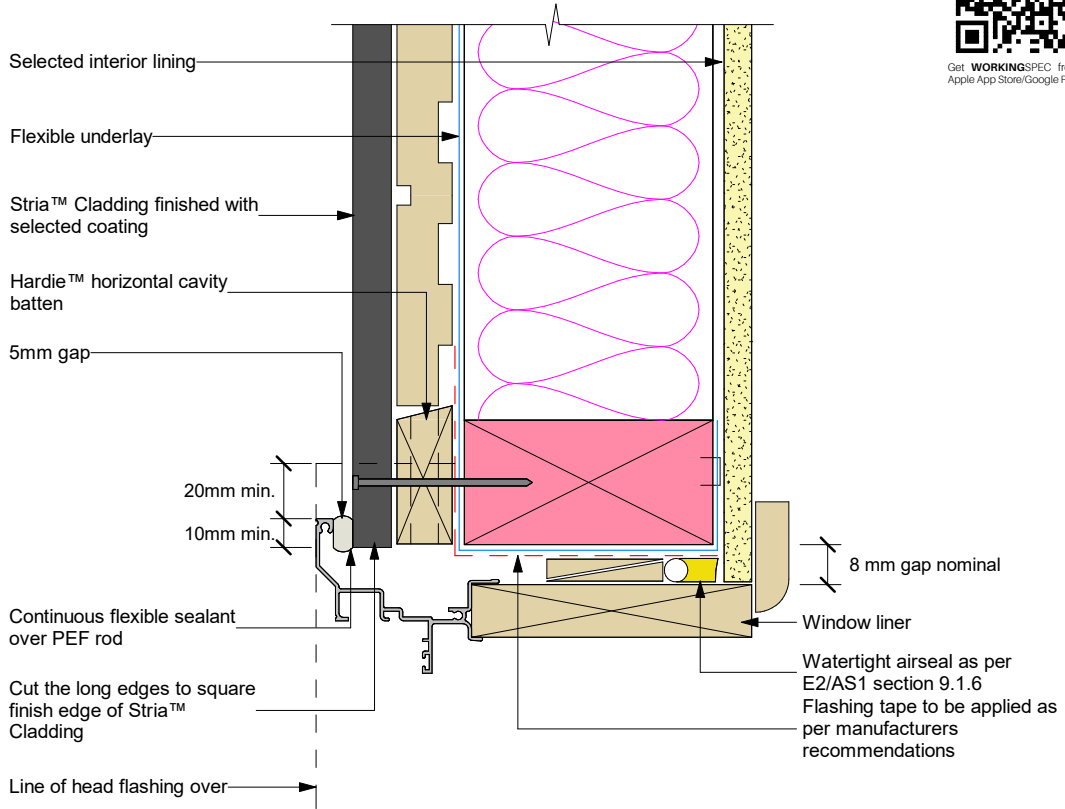
Figure 12: Window sill



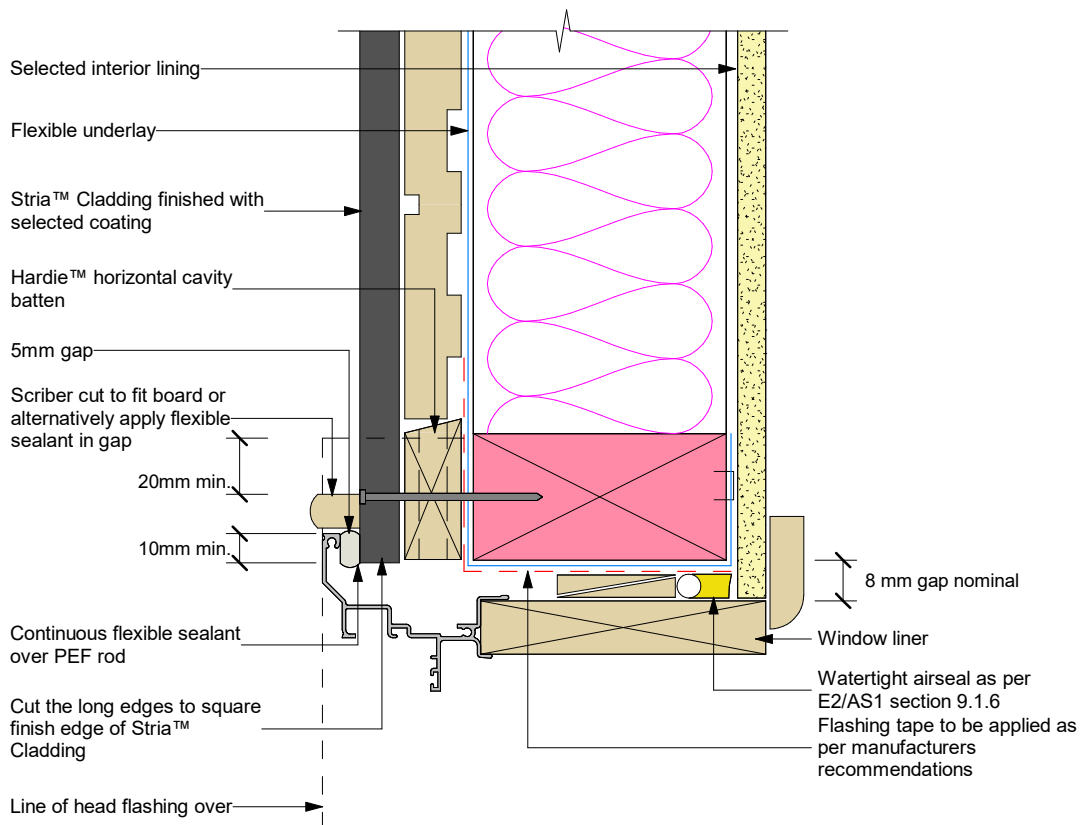
Note: Site cut edges to be primed

**Figure 13: Window jamb**

interactive assembly instructions available  
<http://wksp.nz/jh-str-vwin>  
  
 Get WORKINGSPEC from Apple App Store/Google Play



**Figure 14: Window jamb with scribe**



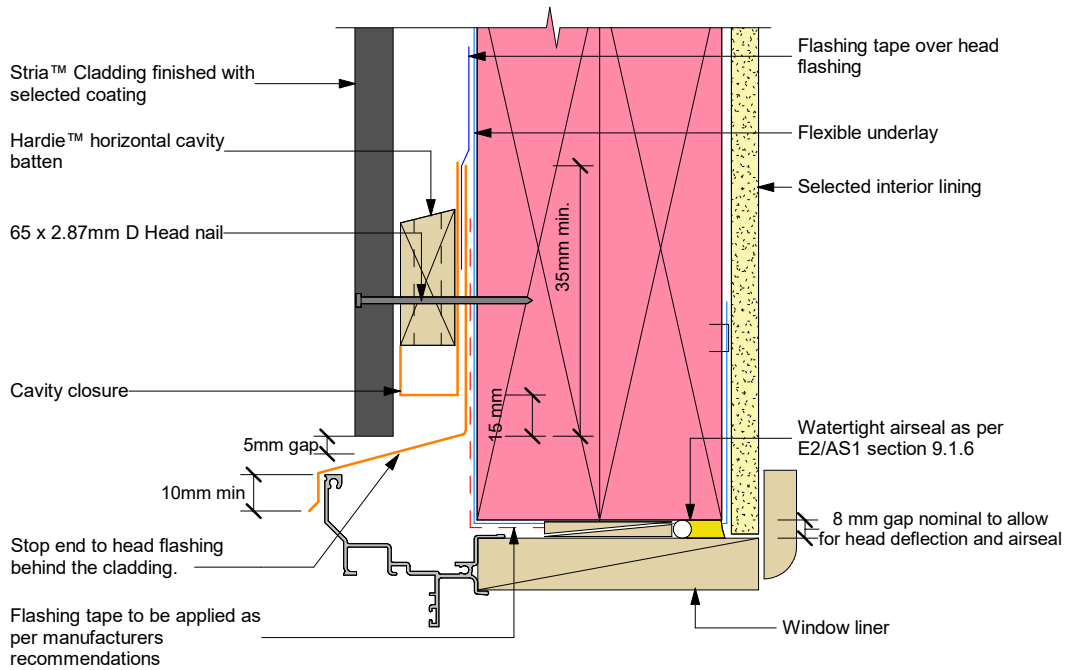
**Figure 15: Window head**

interactive assembly instructions available

<http://wksp.nz/jh-str-vwin>



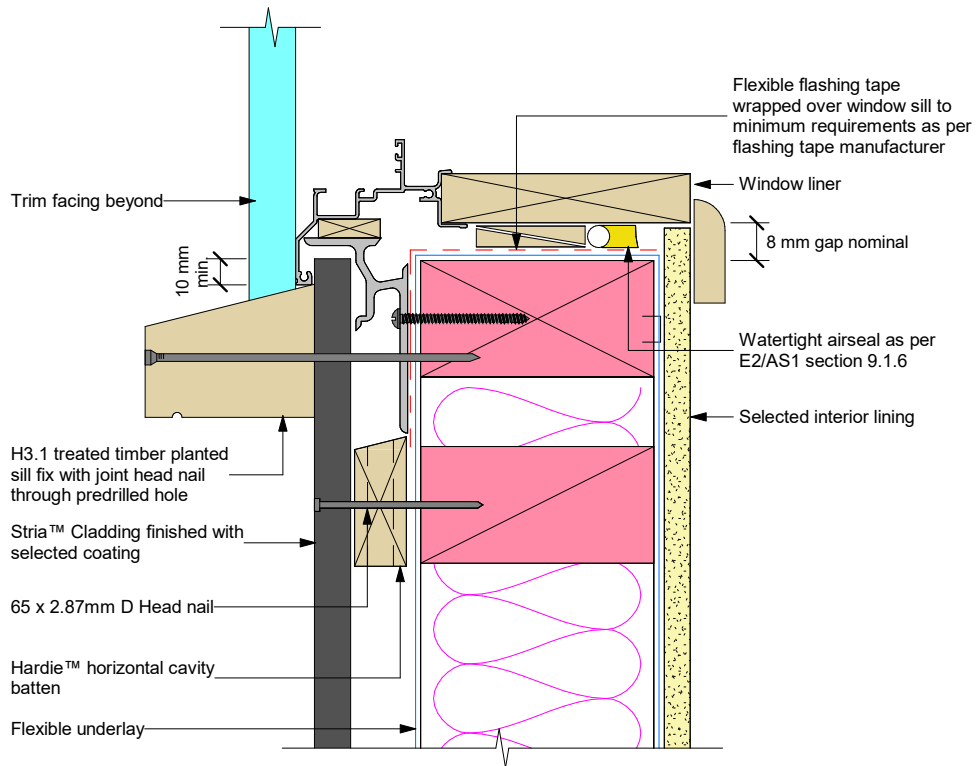
Get **WORKINGSPEC** from Apple App Store/Google Play



**Note:**

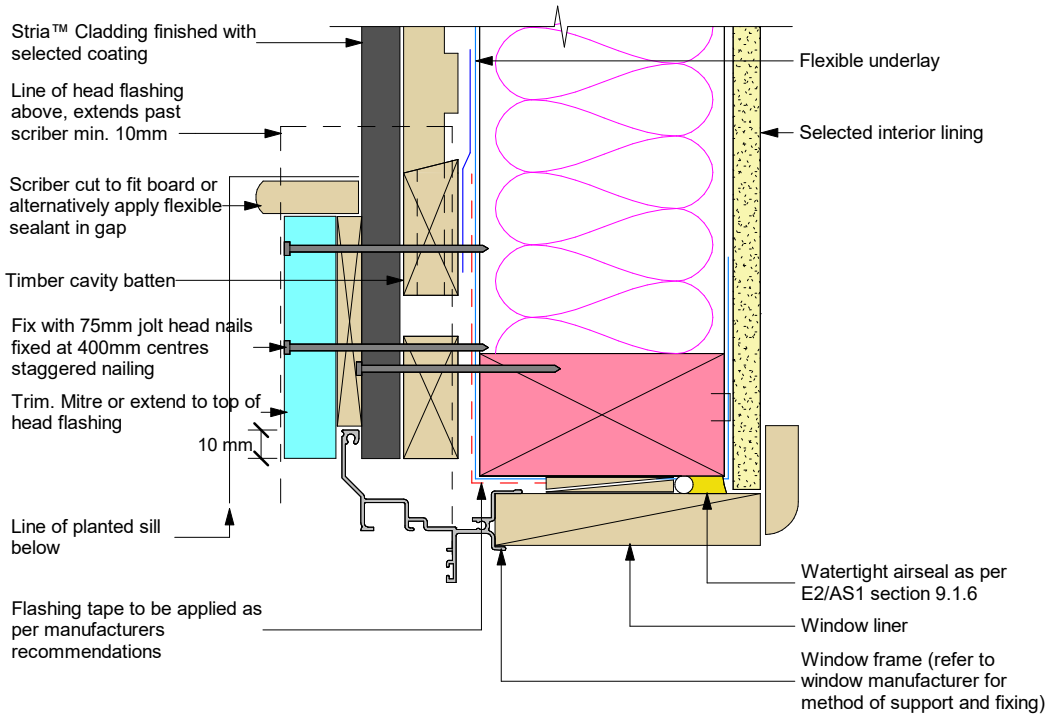
1. Site cut edges to be primed
2. Sealant must be installed between head flashing and window flange in VH and above wind zones. Refer to Figure 71 of E2/AS1
3. Alternatively, the head flashings can be formed with stop ends as per E2/AS1

Figure 16: Window sill with facings

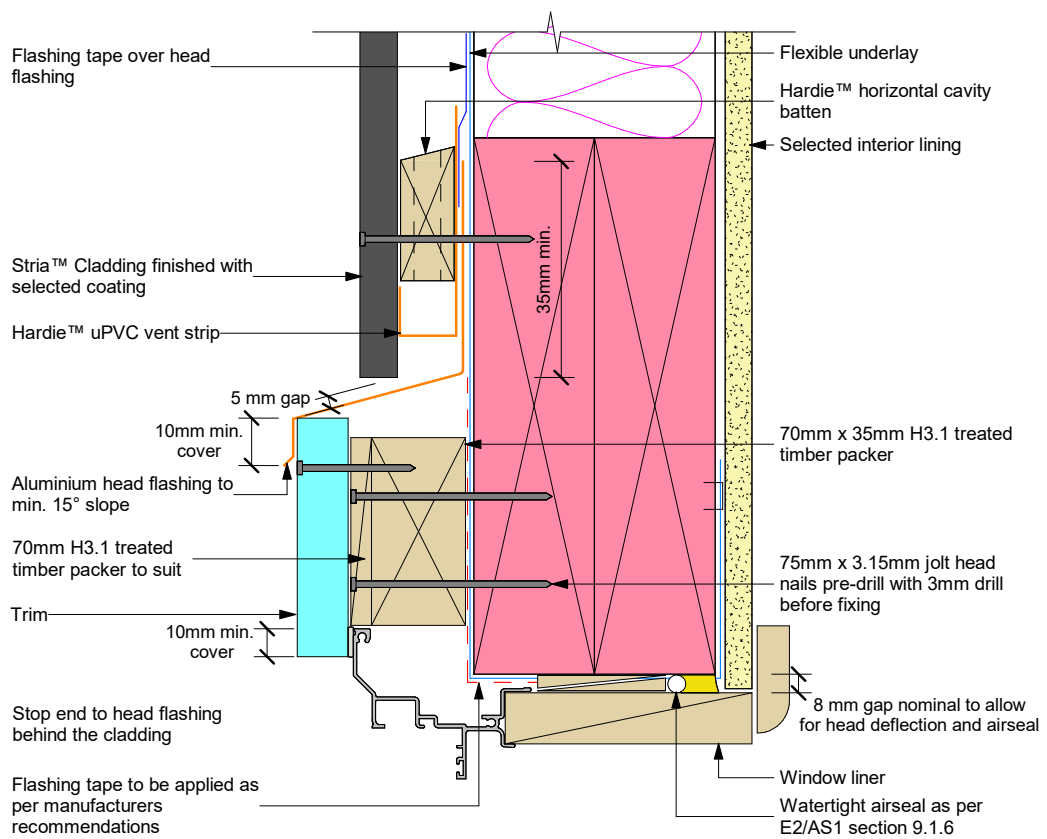


Note: Site cut edges to be primed

**Figure 17: Window jamb with facings**



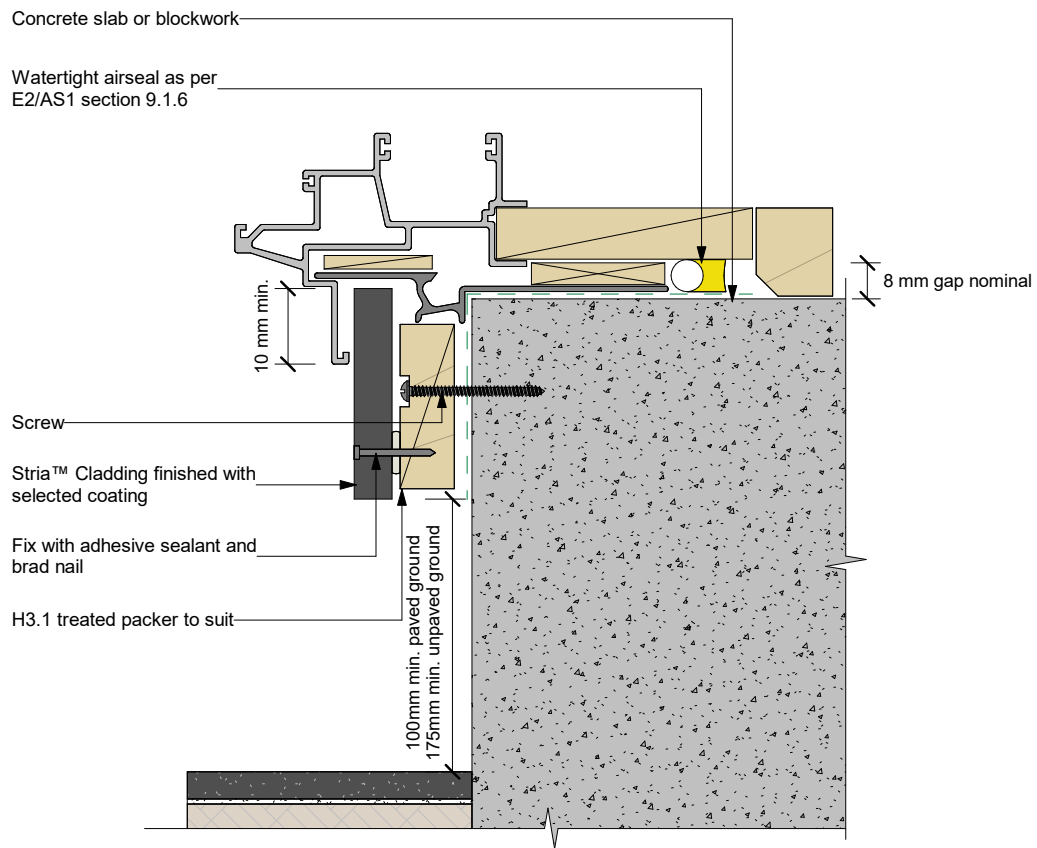
**Figure 18: Window head with facings**



**Note:**

- Sealant must be installed between head flashing and Axent Trim in VH and EH wind zones and SED pressures

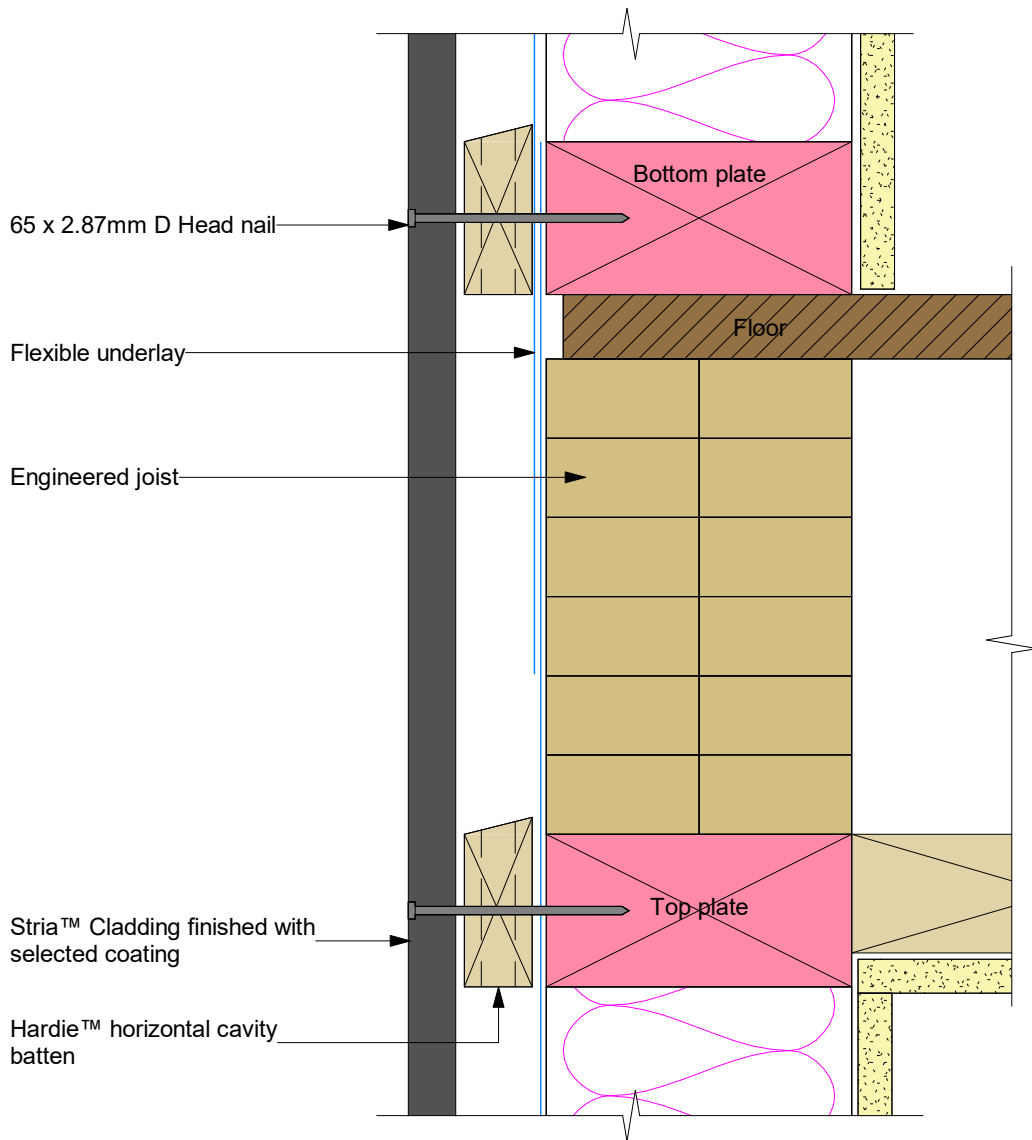
**Figure 19: Door sill support**



Note: Site cut edges to be primed



Figure 20: Continuous cladding over joist at floor level



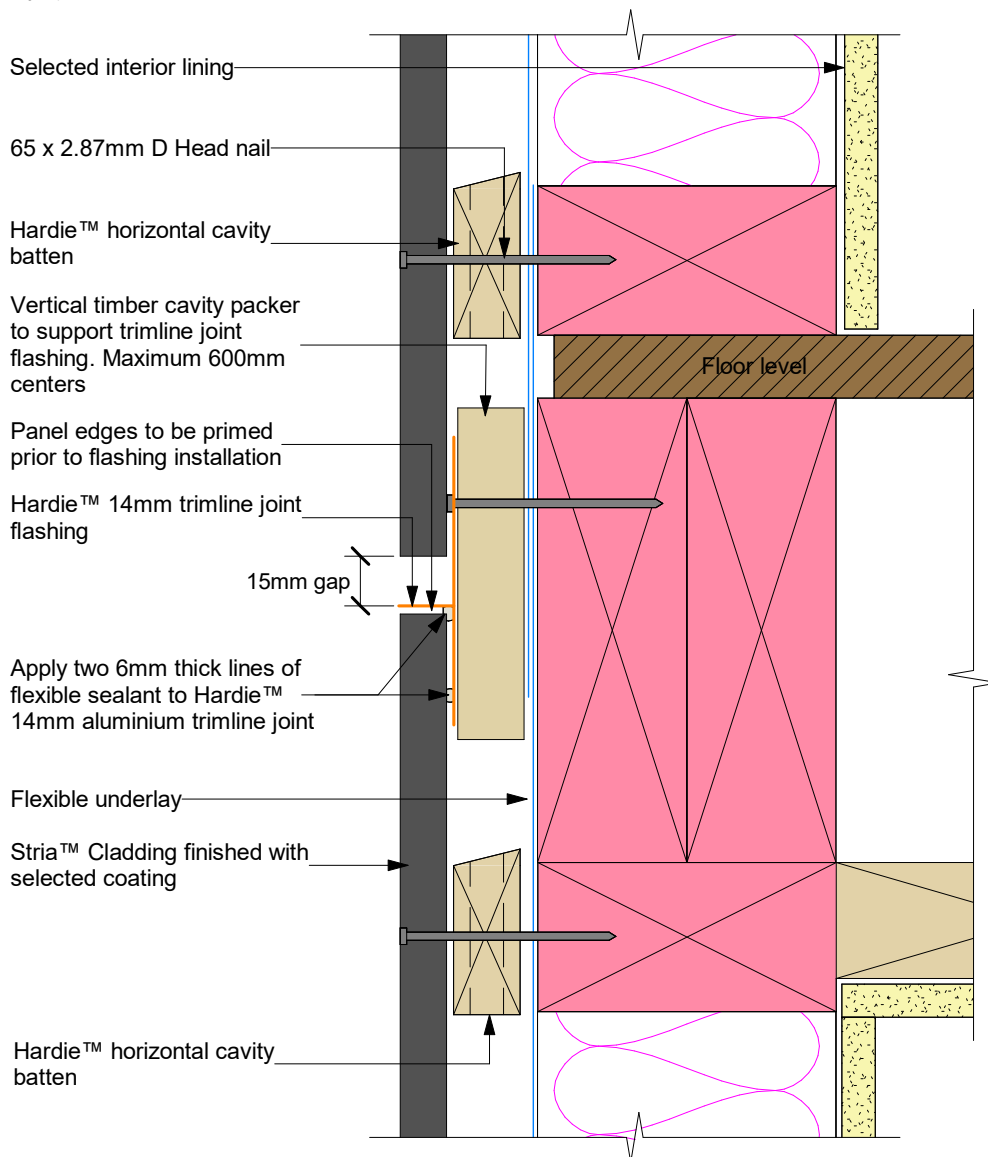
**Figure 21: Trimline joint flashing at floor level**

Interactive assembly instructions available

<http://wksp.nz/jh-str-vmfl>



Get WORKINGSPEC from Apple App Store/Google Play



**Notes:**

- Hardie™ 14mm aluminium trimline joint, take care to ensure continuous seal is formed between panel and the trimline joint
- A James Hardie supplied 'Trimline Horizontal Jointer' flashing will be required over the butt joint of the Hardie™ 14mm aluminium trimline joint
- Site cut edges to be primed
- The flashing to be placed in the centre of the floor joists. Fix cavity battens into floor joists

Figure 22: Trimline joint flashing

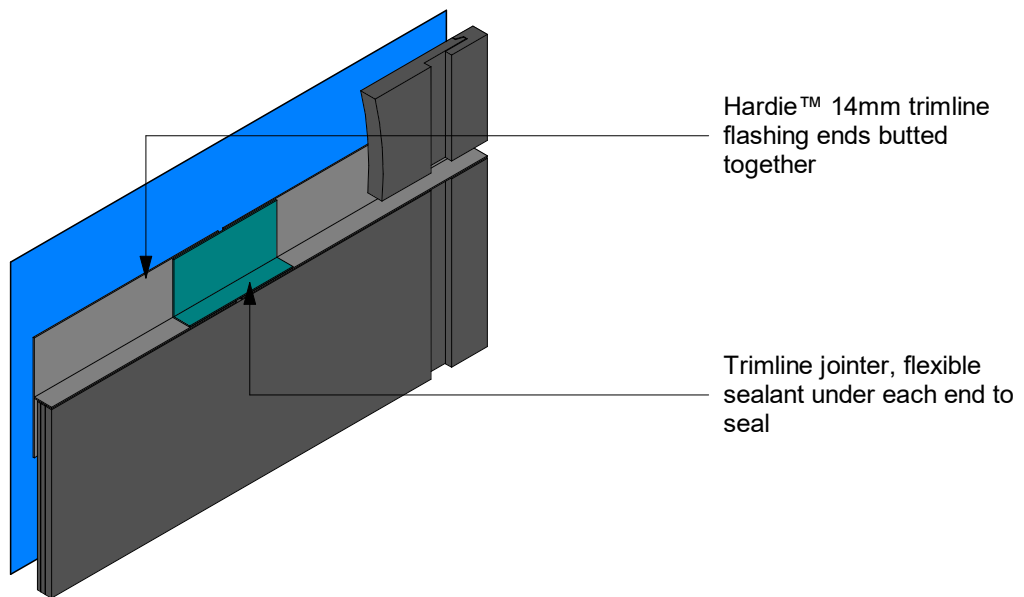


Figure 23: Trimline joint external corner - Option a

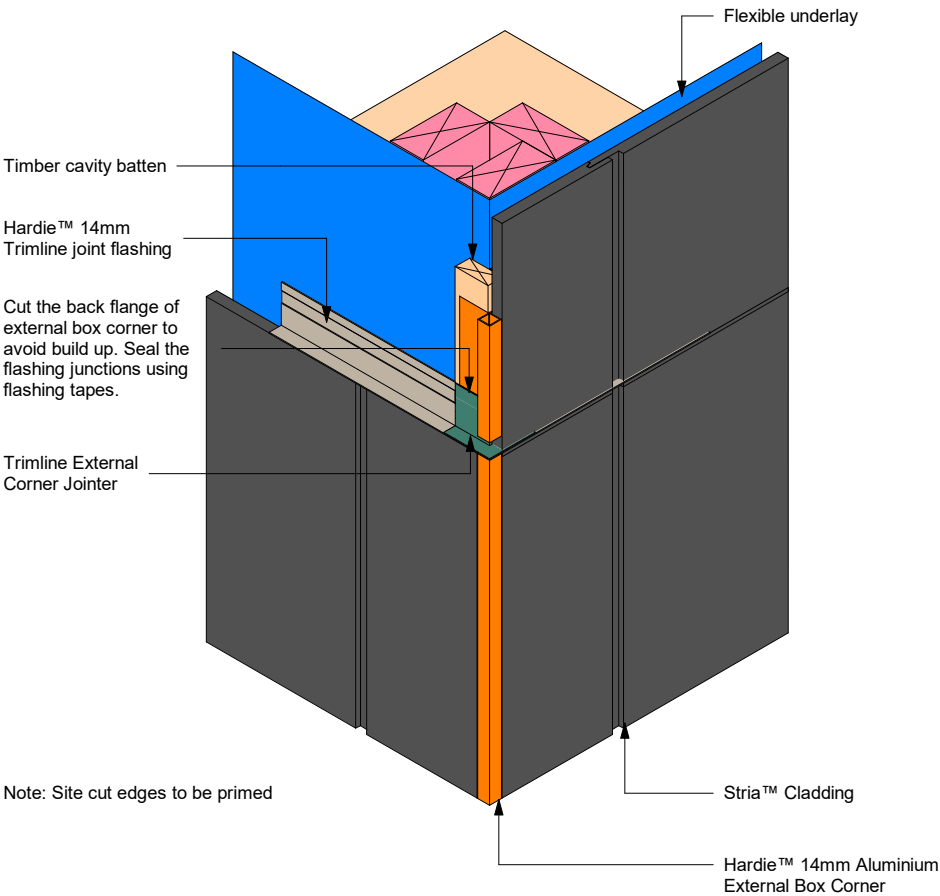


Figure 24: Trimline joint external corner - Option b

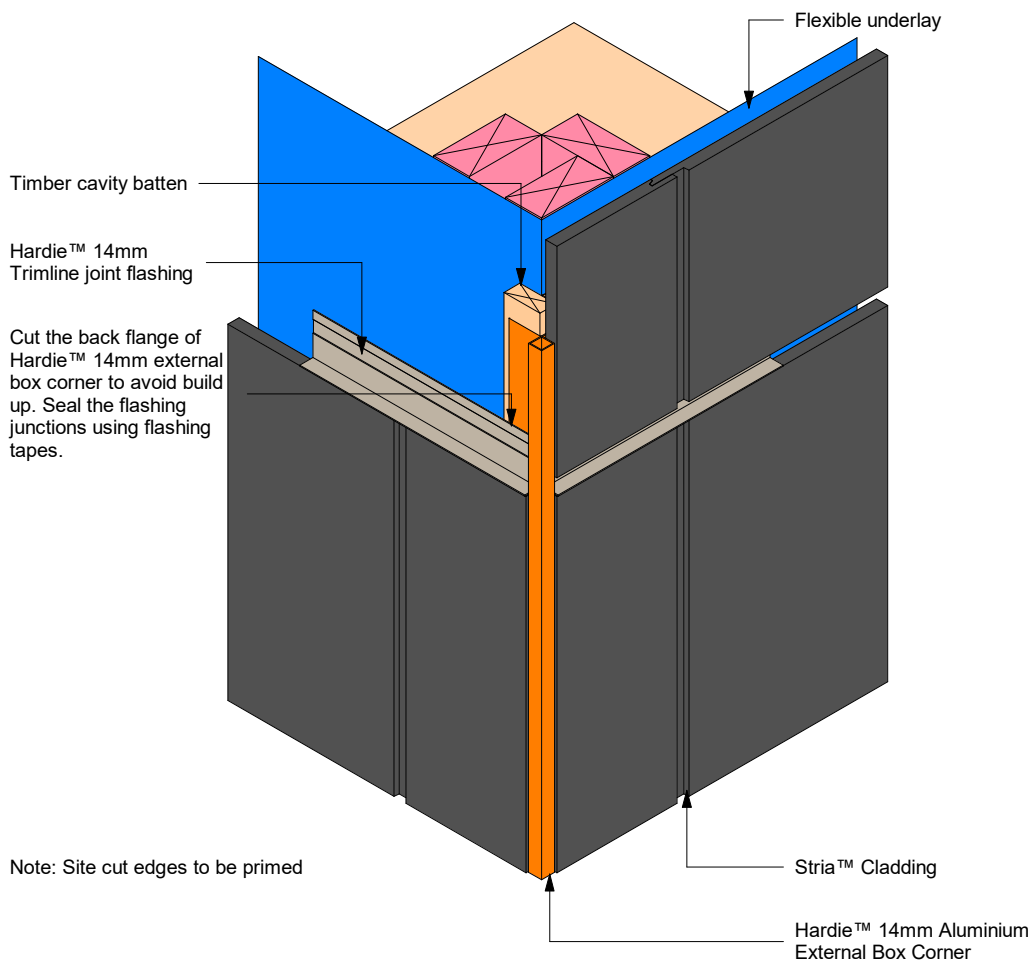
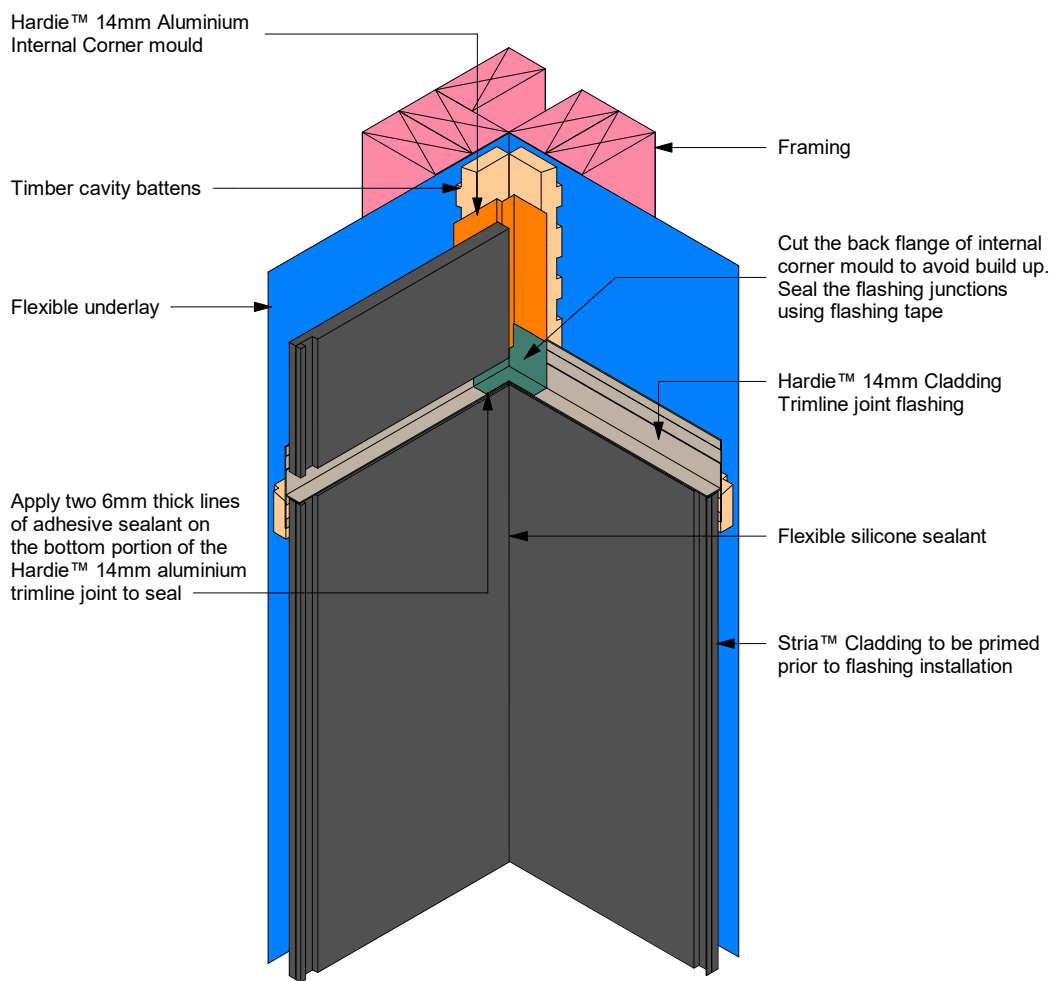
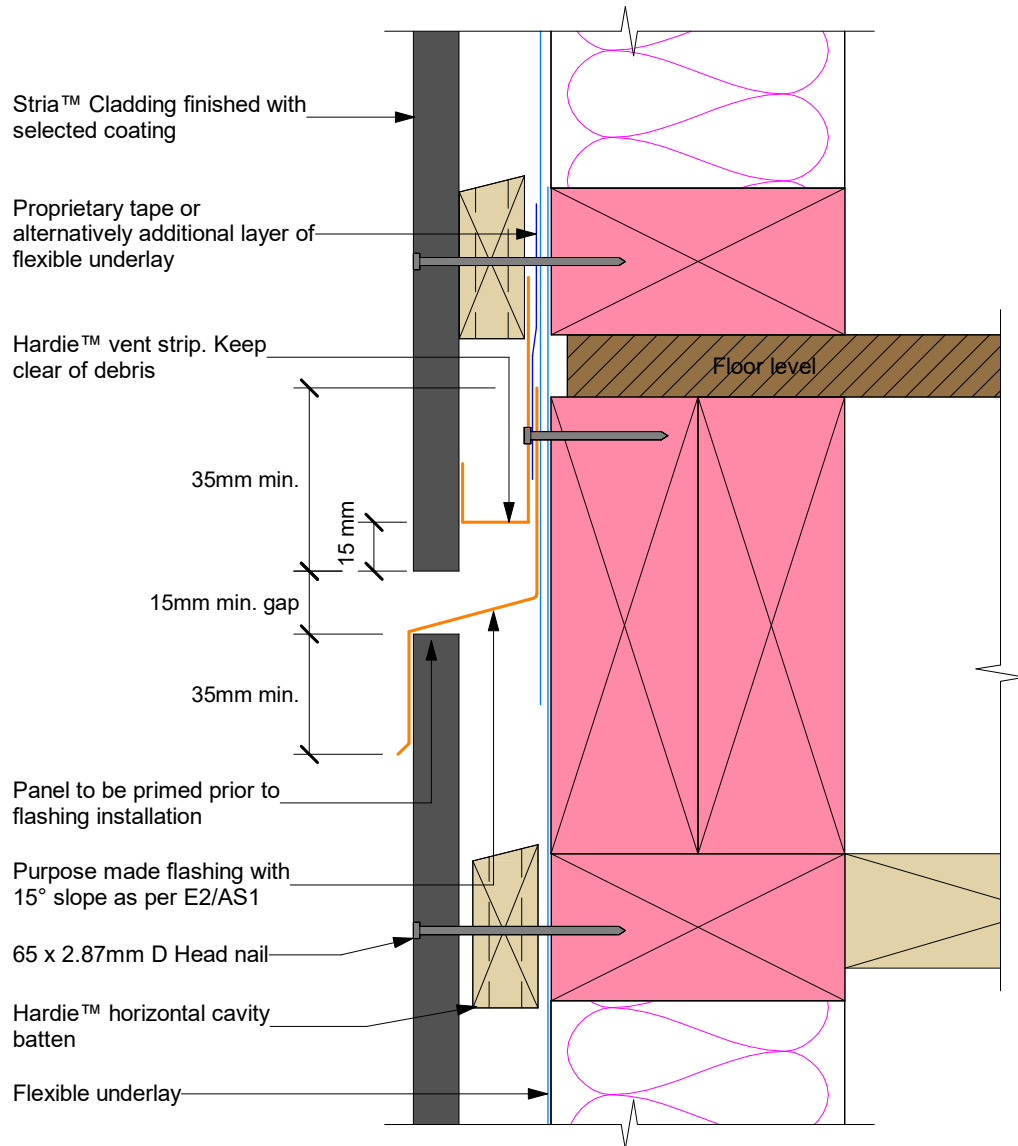


Figure 25: Trimline flashing joint internal corner



**Figure 26: Drained flashing joint at floor level**

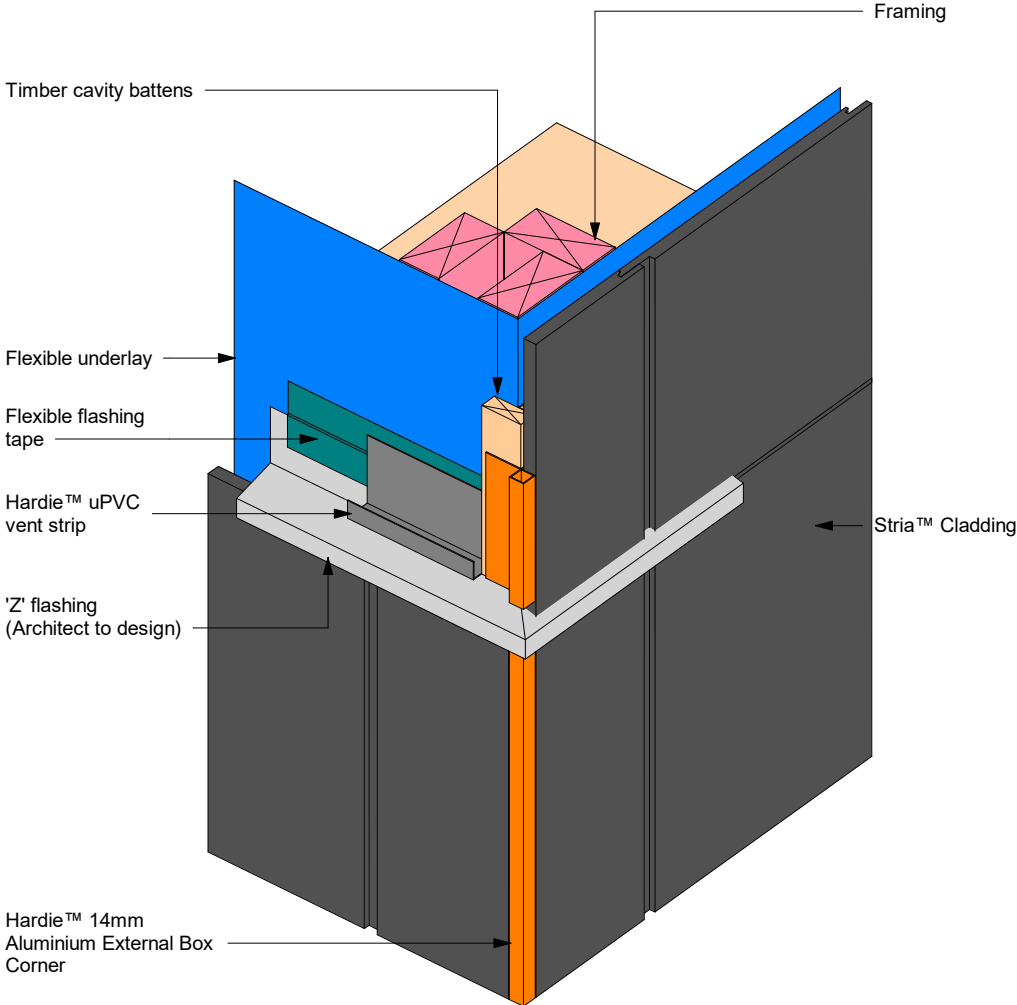


**Notes:**

This detail is required to limit cavities to a maximum of 2 stories or 7 metres. Refer to E2/AS1 clause 9.1.9.4

- Check architect's plans for the type of 'Z' flashing to be used
- Check fixing centres and edge distances
- Cut edges need to be primed

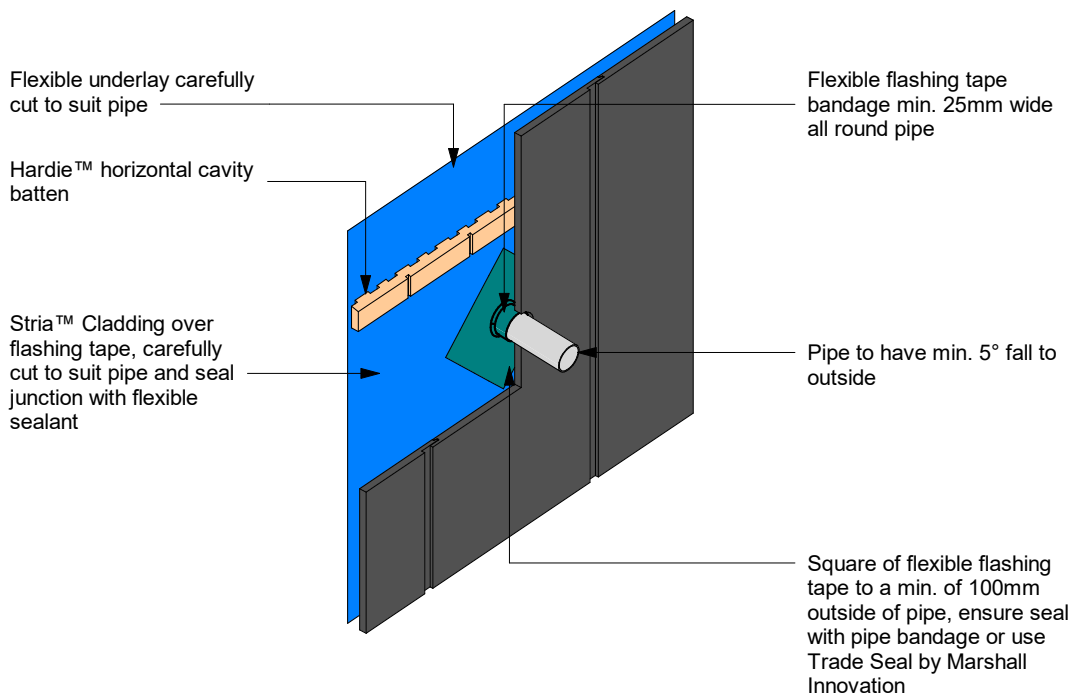
Figure 27: Drained flashing joint at floor joist external corner



Note: Site cut edges to be primed

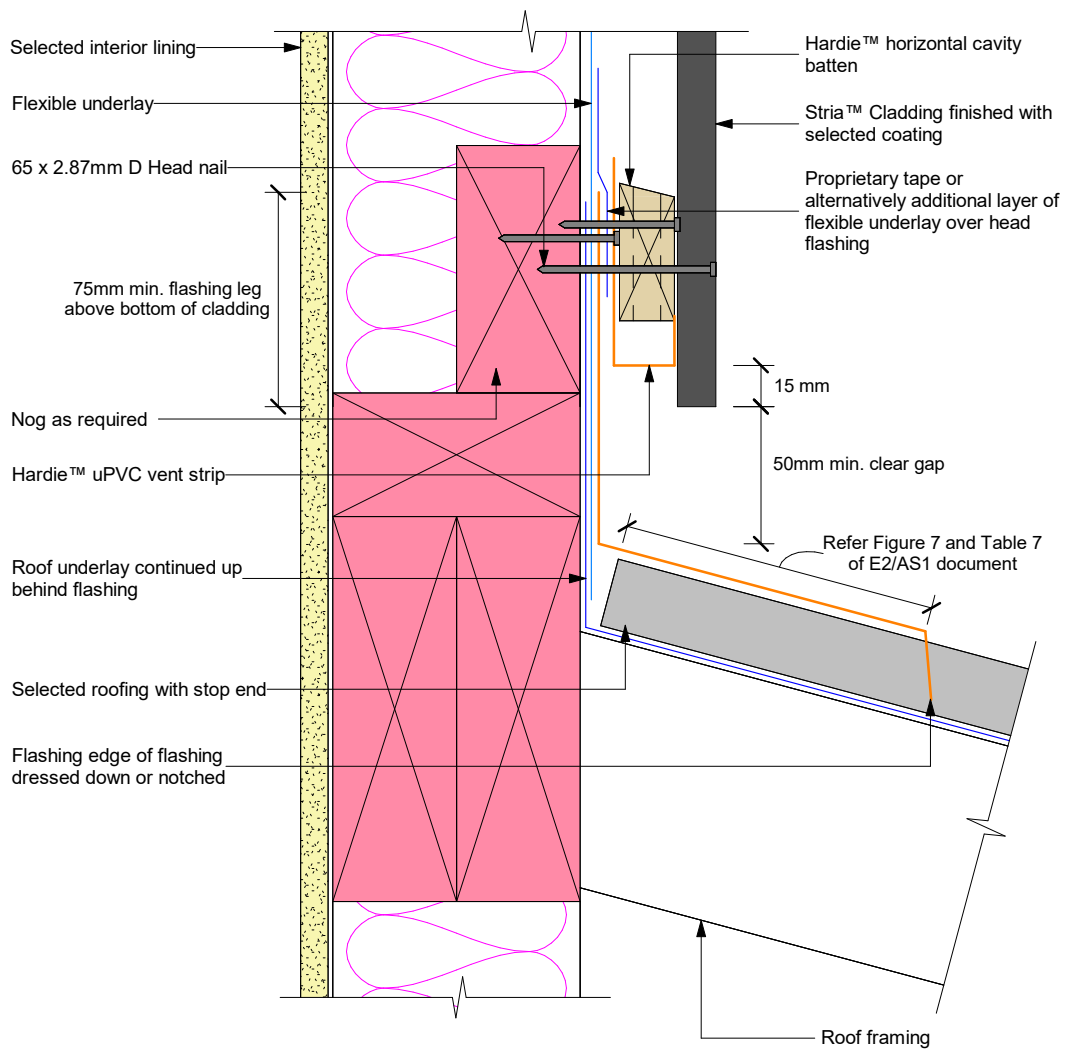


**Figure 28: Pipe penetration**



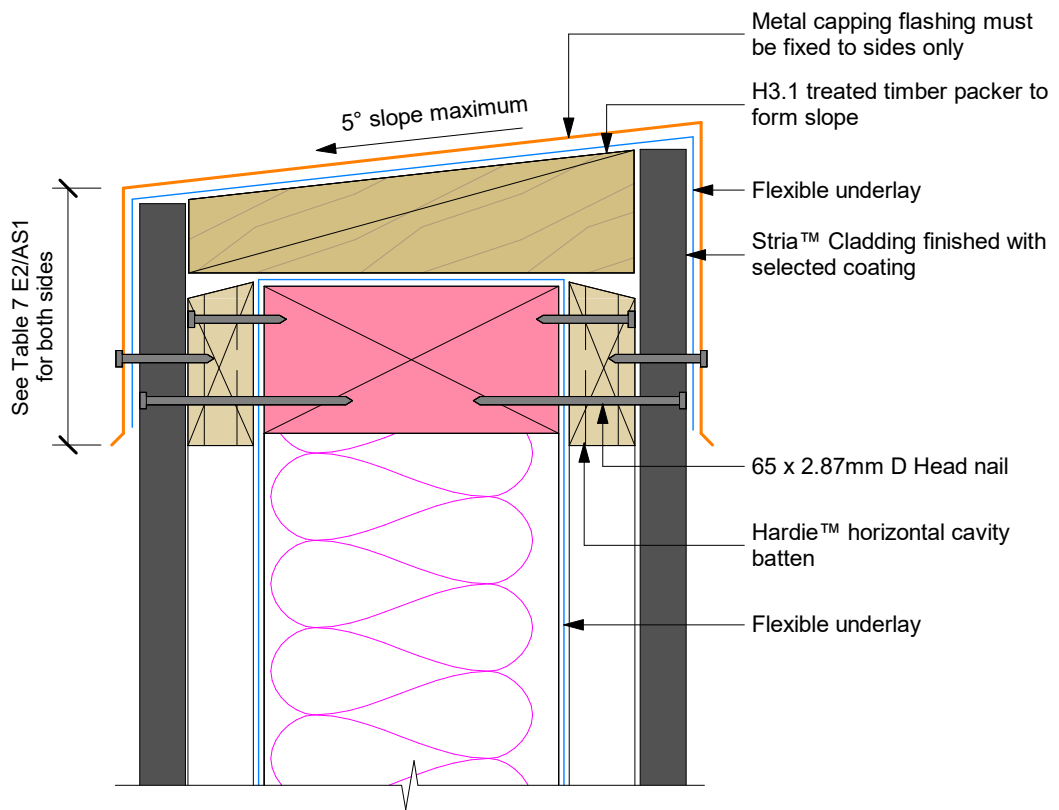
Note: Site cut edges to be primed

**Figure 29: Apron flashing detail**



- Notes:
- When 50 year durability for flashing is required refer to Table 20 NZBC E2/AS1 document
  - Site cut edges to be primed

Figure 30: Parapet flashing



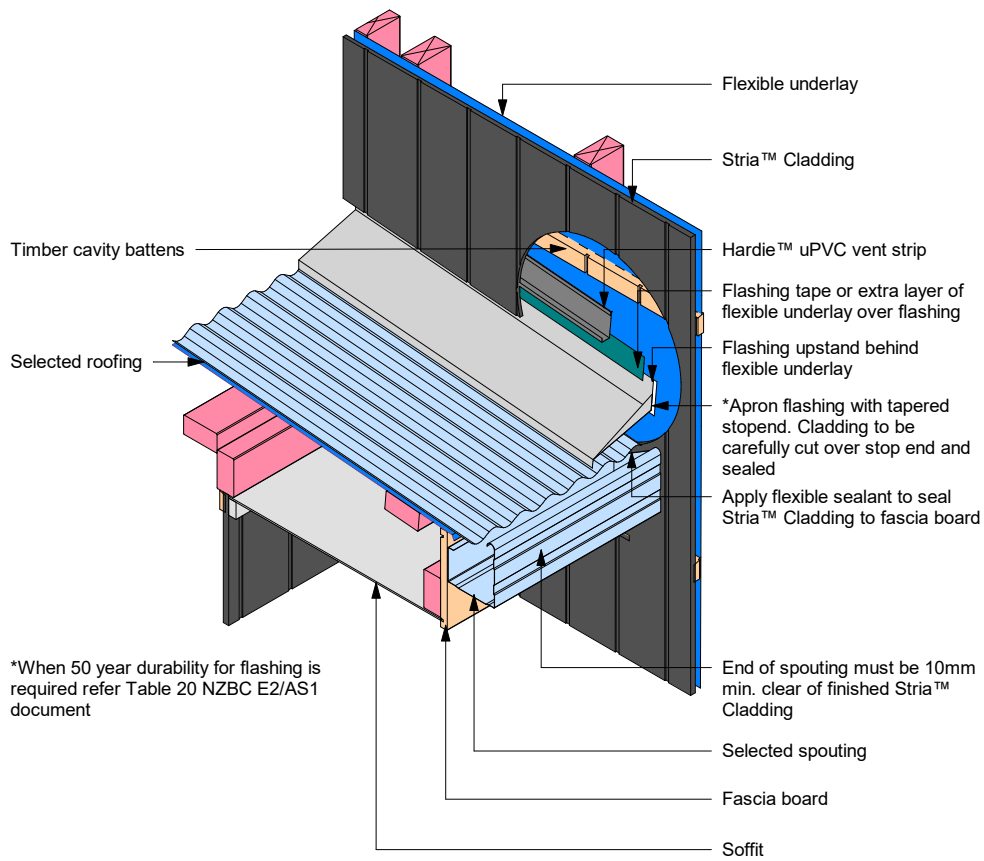
**Figure 31: Roof to wall junction detail**

interactive assembly  
instructions available

<http://wksp.nz/jh-str-vrfw>



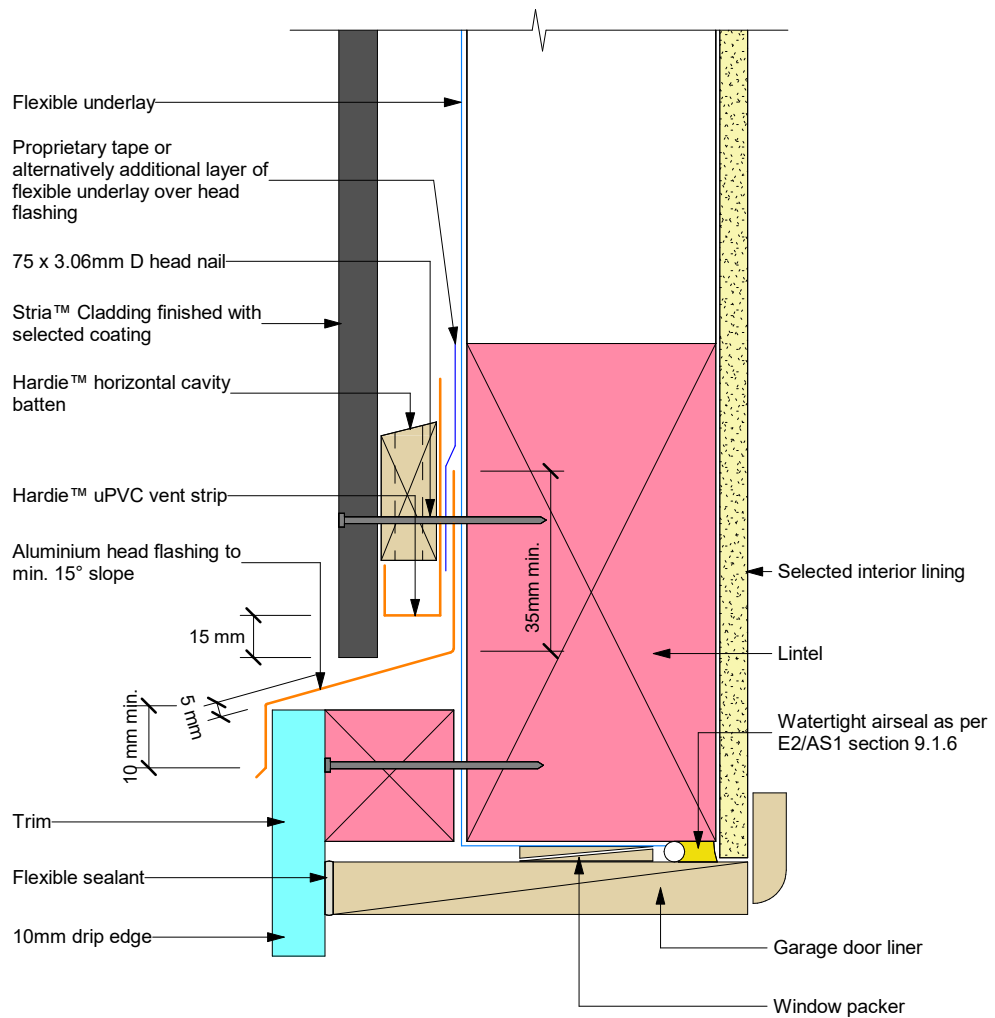
Get **WORKINGSPEC** from  
Apple App Store/Google Play



\*When 50 year durability for flashing is required refer Table 20 NZBC E2/AS1 document

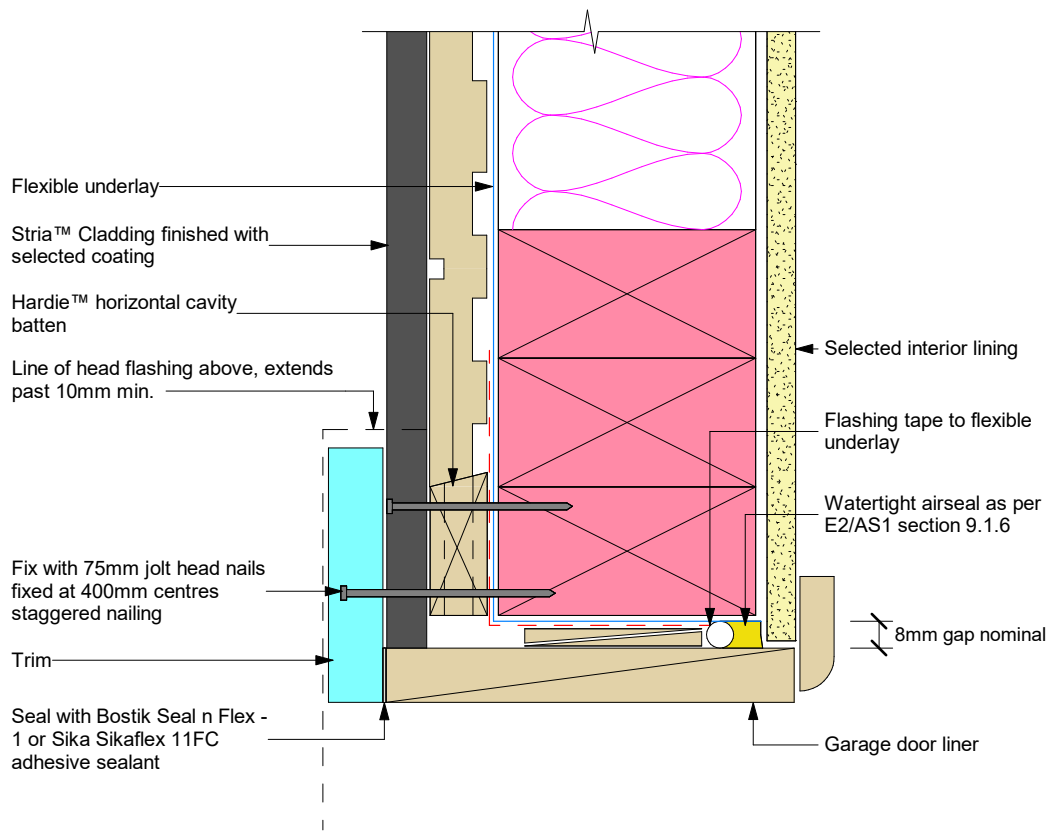
Note: Site cut edges to be primed

**Figure 32: Garage head**



- Sealant must be applied between head flashing and Trim in VH wind zone
- Site cut edges to be primed

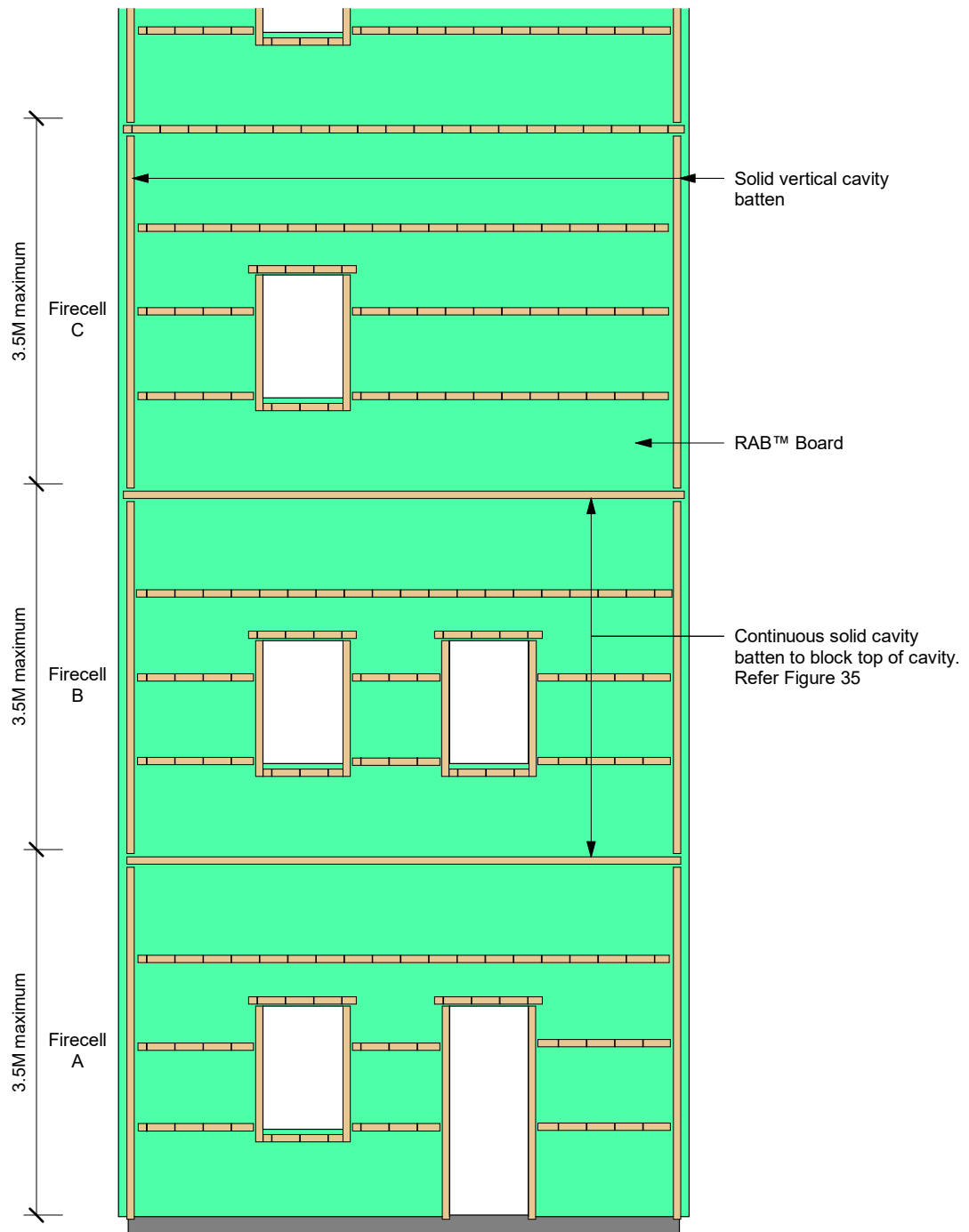
**Figure 33: Garage jamb**



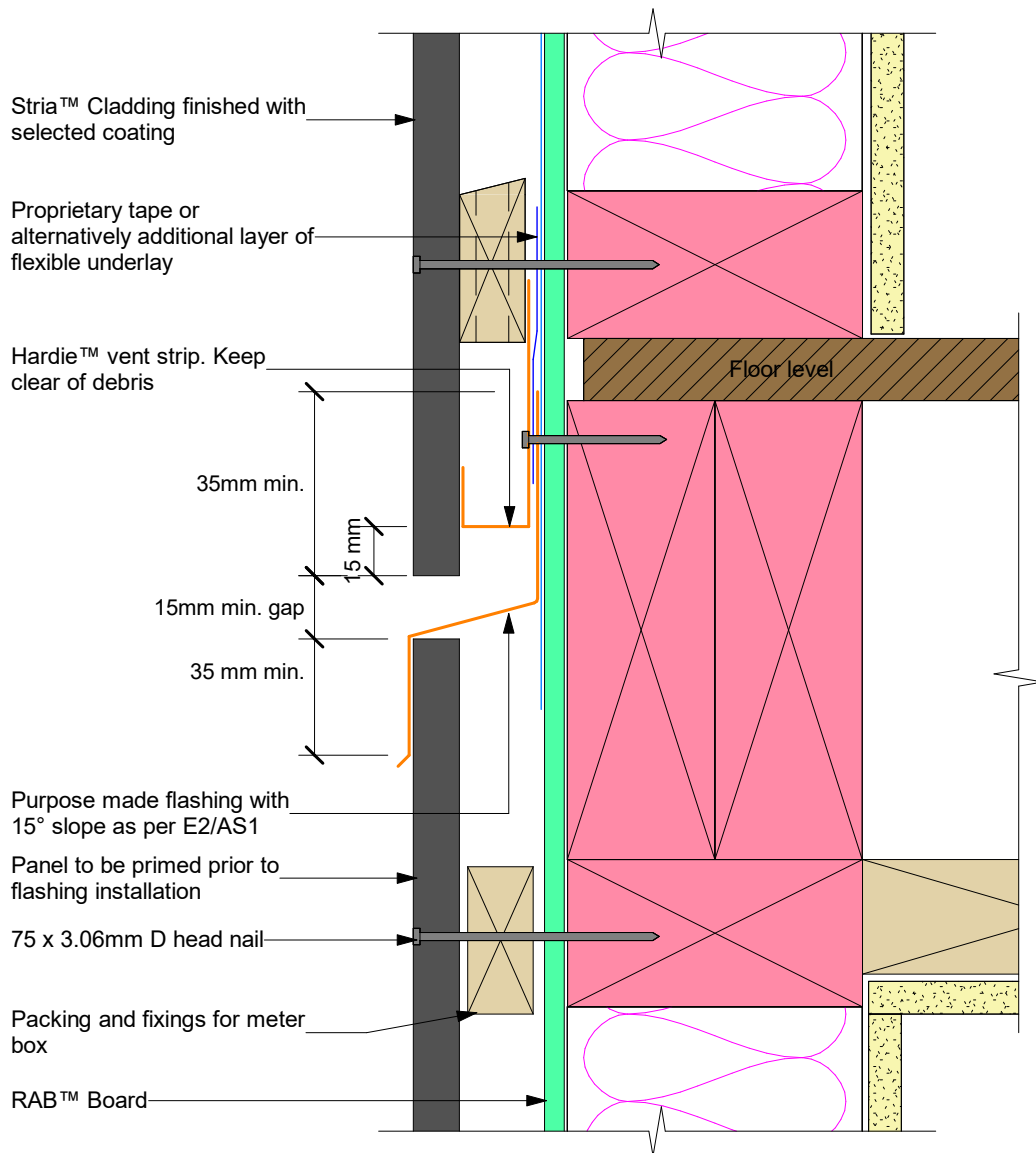
Note: Site cut edges to be primed

For all meter box details please visit our website at [www.jameshardie.co.nz](http://www.jameshardie.co.nz) or Ask James Hardie on **0800 808 868**.

Figure 34: Framing setout building height over 10m



**Figure 35: Vertical fire separation at floor level over 10m**



**Note:**

This detail is required to limit cavities to a maximum of 2 stories or 7 metres. Refer to E2/AS1 clause 9.1.9.4

- Check architect's plans for the type of flashing to be used
- Check fixing centres and edge distances
- Cut edges need to be primed
- The flashing to be placed in the centre of the floor joists. Do not fix timber cavity battens or cladding into floor joists







## Product Warranty

James Hardie New Zealand Limited (“James Hardie”) warrants for a period of 25 years from the date of purchase that the Stria™ Cladding (the “Product”), will be free from defects due to defective factory workmanship or materials and, subject to compliance with the conditions below, will be resistant to cracking, rotting, fire and damage from termite attacks to the extent set out in James Hardie’s relevant published literature current at the time of installation. James Hardie warrants for a period of 15 years from the date of purchase that the accessories supplied by James Hardie will be free from defects due to defective factory workmanship or materials.

Nothing in this document shall exclude or modify any legal rights a customer may have under the Consumer Guarantees Act or otherwise which cannot be excluded or modified at law.

### CONDITIONS OF WARRANTY:

The warranty is strictly subject to the following conditions:

- a) James Hardie will not be liable for breach of warranty unless the claimant provides proof of purchase and makes a written claim either within 30 days after the defect would have become reasonably apparent or, if the defect was reasonably apparent prior to installation, then the claim must be made prior to installation;
- b) this warranty is not transferable;
- c) the Product must be installed and maintained strictly in accordance with the relevant James Hardie literature current at the time of installation and must be installed in conjunction with the components or products specified in the literature. Further, all other products, including coating and jointing systems, applied to or used in conjunction with the Product must be applied or installed and maintained strictly in accordance with the relevant manufacturer’s instructions and good trade practice;
- d) the project must be designed and constructed in strict compliance with all relevant provisions of the current New Zealand Building Code (“NZBC”), regulations and standards;
- e) the claimant’s sole remedy for breach of warranty is (at James Hardie’s option) that James Hardie will either supply replacement product, rectify the affected product or pay for the cost of the replacement or rectification of the affected product;
- f) James Hardie will not be liable for any losses or damages (whether direct or indirect) including property damage or personal injury, consequential loss, economic loss or loss of profits, arising in contract or negligence or howsoever arising. Without limiting the foregoing James Hardie will not be liable for any claims, damages or defects arising from or in any way attributable to poor workmanship, poor design or detailing, settlement or structural movement and/or movement of materials to which the Product is attached, incorrect design of the structure, acts of God including but not limited to earthquakes, cyclones, floods or other severe weather conditions or unusual climatic conditions, efflorescence or performance of paint/coatings applied to the Product, normal wear and tear, growth of mould, mildew, fungi, bacteria, or any organism on any Product surface or Product (whether on the exposed or unexposed surfaces);
- g) all warranties, conditions, liabilities and obligations other than those specified in this warranty are excluded to the fullest extent allowed by law;
- h) if meeting a claim under this warranty involves re-coating of Products, there may be slight colour differences between the original and replacement Products due to the effects of weathering and variations in materials over time.

Disclaimer: The recommendations in James Hardie’s literature are based on good building practice, but are not an exhaustive statement of all relevant information and are subject to conditions (c), (d), (f) and (g) above. James Hardie has tested/assessed the performance of the Stria™ Cladding when installed in accordance with the relevant Stria™ Cladding technical specification, in accordance with the standards and verification methods required by the NZBC and those test results demonstrate the product complies with the performance criteria established by the NZBC. However, as the successful performance of the relevant system depends on numerous factors outside the control of James Hardie (e.g. quality of workmanship and design) James Hardie shall not be liable for the recommendations made in its literature and the performance of the relevant system, including its suitability for any purpose or ability to satisfy the relevant provisions of the NZBC, regulations and standards, as it is the responsibility of the building designer to ensure that the details and recommendations provided in the relevant James Hardie installation manual are suitable for the intended project and that specific design is conducted where appropriate.

© 2022. James Hardie New Zealand Limited. TM and ® denotes a Trademark or Registered Mark owned by James Hardie Technology Limited.

