

# COVER SHEET

KS1000 RW WALL_VERTICAL Q4_2020				
DATE	DRAWING NAME	DRG_REF	REVISION	APPROVED
24.09.20	COVER SHEET	RW_VS_00	-	JS
24.09.20	KS1000 RW WALL PANEL DIMENSIONS	RW_VS_01	-	JS
24.09.20	PRIMARY FIXING LOCATIONS	RW_VS_02	-	JS
24.09.20	PANEL LAP DETAILS	RW_VS_03	-	JS
24.09.20	BASE DETAILS 1	RW_VS_04	-	JS
24.09.20	BASE DETAIL 2	RW_VS_05	-	JS
24.09.20	EXTERNAL CORNER	RW_VS_06	-	JS
24.09.20	INTERNAL CORNER	RW_VS_07	-	JS
24.09.20	ABUTMENT TO CONCRETE - FLUSH	RW_VS_08	-	JS
24.09.20	ABUTMENT TO CONCRETE - OVERHANG	RW_VS_09	-	JS
24.09.20	VERTICAL TO HORIZONTAL BREAK DETAIL	RW_VS_10	-	JS
24.09.20	VERGE OVERHANG	RW_VS_11	-	JS
24.09.20	WINDOW HEAD DETAIL	RW_VS_12	-	JS
24.09.20	PERSONNEL DOOR DETAIL	RW_VS_13	-	JS
24.09.20	OVERHEAD DOOR DETAIL	RW_VS_14	-	JS
24.09.20	LOUVRE DETAIL	RW_VS_15	-	JS
24.09.20	PIPE PENETRATION DETAIL	RW_VS_16	-	JS
24.09.20	KS1100 CS GUTTER KS1000 RW ROOF & VERTICAL WALL	RW_VS_17	-	JS
24.09.20	EAVES GUTTER DETAIL	RW_VS_18	-	JS

SYSTEM KS1000 RW WALL_VERTICAL Q4_2020.DWG			
DESCRIPTION COVER SHEET			
APPROVED BY JS	DATE 24.09.20	REVISION -	
DRG REF: RW_VS_00	SCALE 1:1	SHEET 1 of 1	PAPER SIZE A4

This document remains the property of Kingspan Ltd under copyright laws. Licence is granted to use this document and its contents in connection with Kingspan Ltd products only.  
©Kingspan Ltd

DO NOT SCALE. IF IN DOUBT ASK

New Zealand: Kingspan Ltd  
97 Montreal St  
Christchurch  
Tel: 03 358 7536  
Fax: 03 358 7539  
Freephone: 0800 121280  
email: tech@kingspanpanels.co.nz  
www.kingspanpanels.co.nz

  
**Kingspan.**  
Insulated Panels

# KS1000 RW WALL PANEL DIMENSIONS

NOTE: ABOVE DIMENSIONS ARE NOMINAL, ACTUAL DIMENSIONS WILL VARY DUE TO MANUFACTURING TOLERANCES. EXACTLY PRECISE DIMENSIONS MUST ALWAYS BE MEASURED FROM ACTUAL SAMPLES ALL DIMENSIONS IN MILLIMETRES.

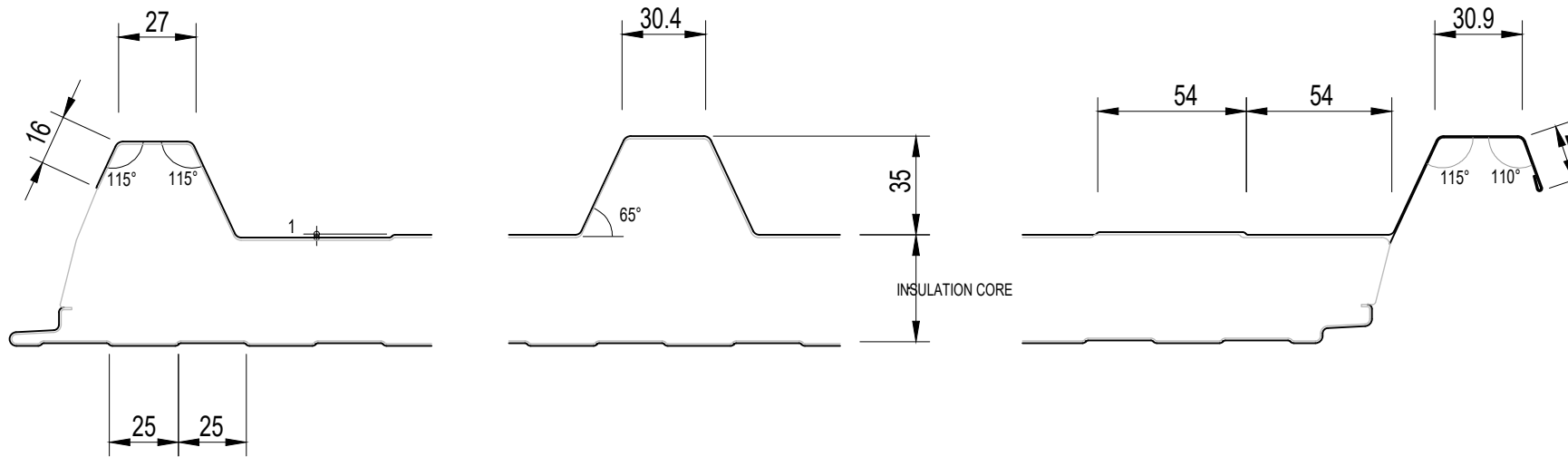
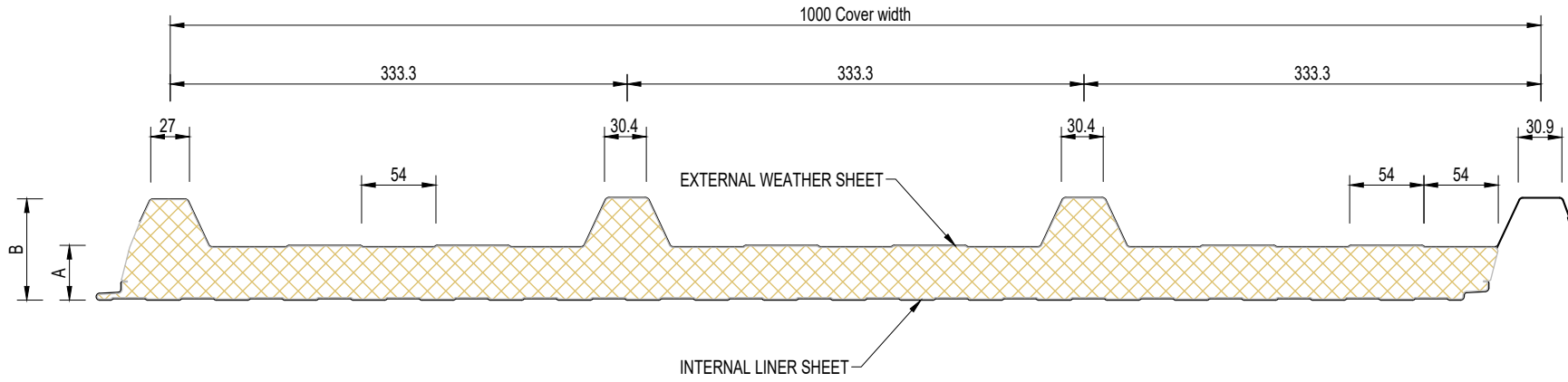

AVAILABLE PANEL THICKNESSES					
A- Core Thickness (mm)	40.00	60.00	70.00	100.00	120.00
B- Overall Dimension (mm)	75.00	95.00	110.00	135.00	155.00
Weight kg/m <sup>2</sup> 0.5/0.4 Steel	10.3	10.70	11.1	12.3	13.1
Thermal Insulation 'R' <sub>Value</sub> - m <sup>2</sup> K / W m <sup>2</sup> K/W Calculated at K = 0.020 W/m <sup>2</sup>	2.39	3.44	3.96	5.50	6.53

SYSTEM KS1000 RW WALL_VERTICAL Q4_2020.DWG			
DESCRIPTION KS1000 RW WALL PANEL DIMENSIONS			
APPROVED BY JS	DATE 24.09.20	REVISION -	
DRG REF: RW_VS_01	SCALE 1:5	SHEET 1 of 1	PAPER SIZE A4

This document remains the property of Kingspan Ltd under copyright laws. Licence is granted to use this document and its contents in connection with Kingspan Ltd products only.  
©Kingspan Ltd

DO NOT SCALE. IF IN DOUBT ASK

New Zealand: Kingspan Ltd  
97 Montreal St  
Christchurch  
Tel: 03 358 7536  
Fax: 03 358 7539  
Freephone: 0800 121280  
email: tech@kingspanpanels.co.nz  
www.kingspanpanels.co.nz

# PRIMARY FIXING LOCATIONS

VALLEY (WALL PANELS)

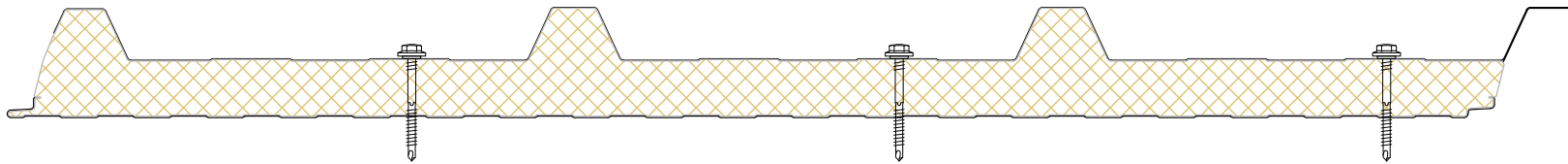

KS1000 RW WALL PANEL PRIMARY FIXING LOCATIONS.  
HORIZONTALLY OR VERTICALLY LAID

SYSTEM KS1000 RW WALL_VERTICAL Q4_2020.DWG			
DESCRIPTION PRIMARY FIXING LOCATIONS			
APPROVED BY JS	DATE 24.09.20	REVISION -	
DRG REF: RW_VS_02	SCALE 1:5	SHEET 1 of 1	PAPER SIZE A4

This document remains the property of Kingspan Ltd under copyright laws. Licence is granted to use this document and its contents in connection with Kingspan Ltd products only.  
©Kingspan Ltd

DO NOT SCALE. IF IN DOUBT ASK

New Zealand: Kingspan Ltd  
97 Montreal St  
Christchurch  
Tel: 03 358 7536  
Fax: 03 358 7539  
Freephone: 0800 121280  
email: tech@kingspanpanels.co.nz  
www.kingspanpanels.co.nz



**Kingspan**  
Insulated Panels

# PANEL LAP DETAILS

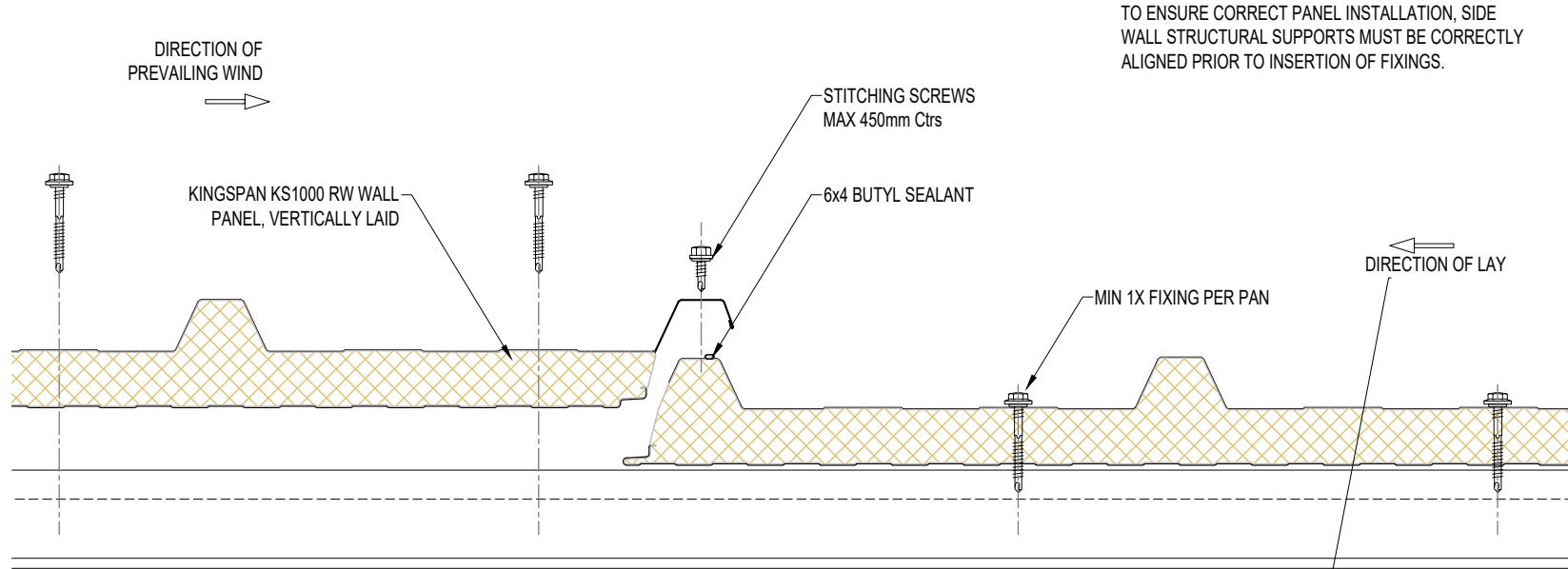

TO ENSURE CORRECT PANEL INSTALLATION, SIDE WALL STRUCTURAL SUPPORTS MUST BE CORRECTLY ALIGNED PRIOR TO INSERTION OF FIXINGS.

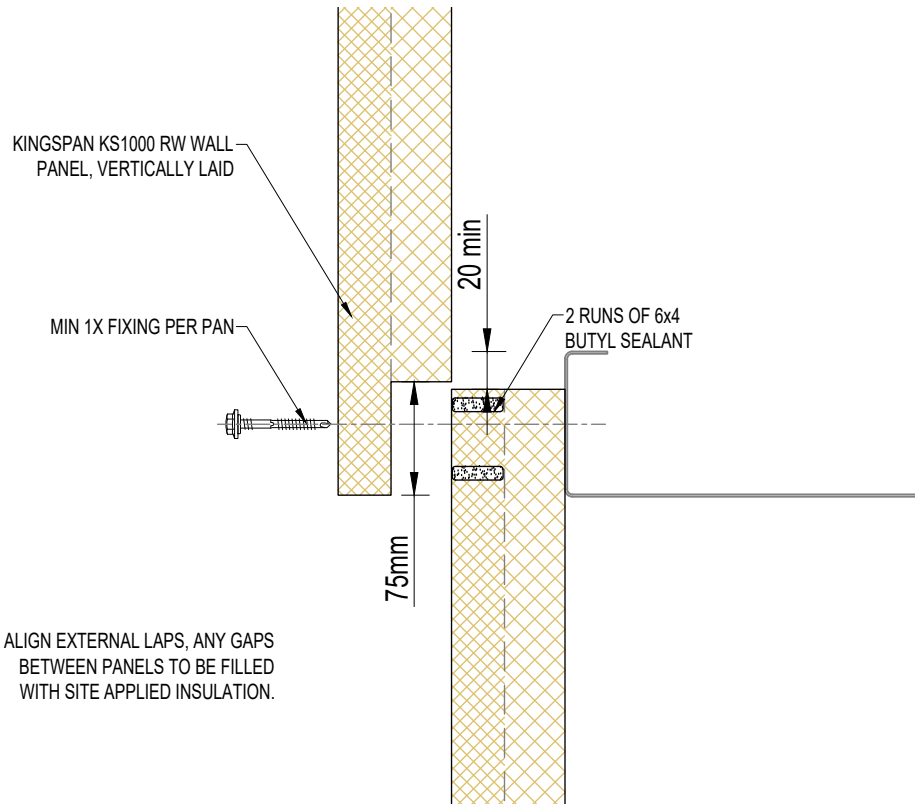

TO ALIGN EXTERNAL LAPS, ANY GAPS BETWEEN PANELS TO BE FILLED WITH SITE APPLIED INSULATION.

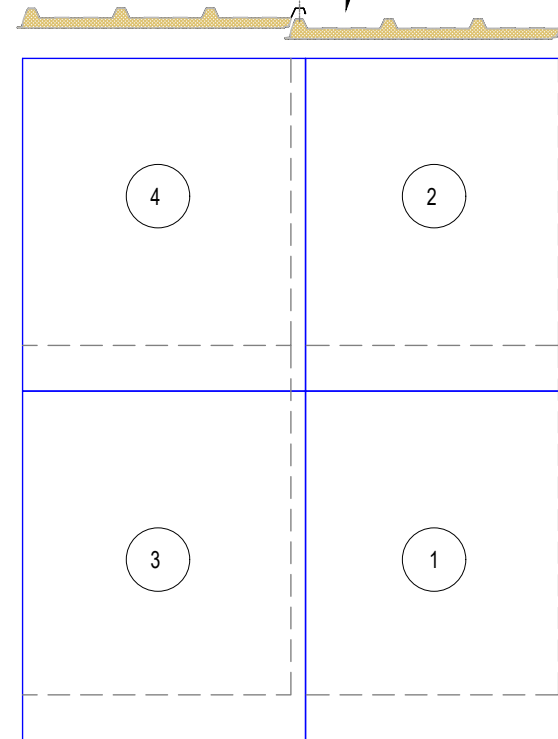

SYSTEM KS1000 RW WALL_VERTICAL Q4_2020.DWG			
DESCRIPTION PANEL LAP DETAILS			
APPROVED BY JS	DATE 24.09.20	REVISION -	
DRG REF: RW_VS_03	SCALE 1:5	SHEET 1 of 1	PAPER SIZE A4
This document remains the property of Kingspan Ltd under copyright laws. Licence is granted to use this document and its contents in connection with Kingspan Ltd products only. ©Kingspan Ltd			

DO NOT SCALE. IF IN DOUBT ASK

New Zealand: Kingspan Ltd  
97 Montreal St  
Christchurch  
Tel: 03 358 7536  
Fax: 03 358 7539  
Freephone: 0800 121280  
email: tech@kingspanpanels.co.nz  
www.kingspanpanels.co.nz

# BASE DETAILS 1

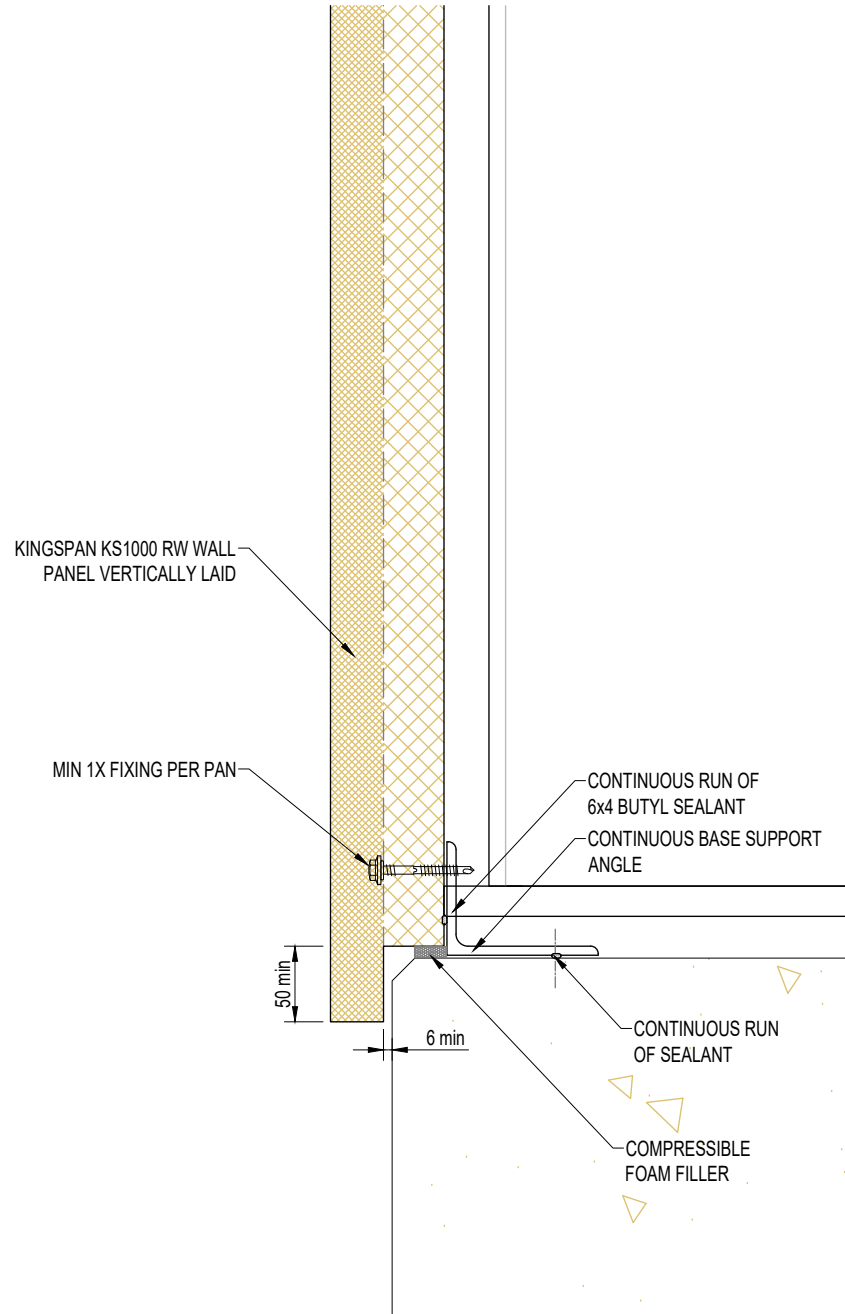
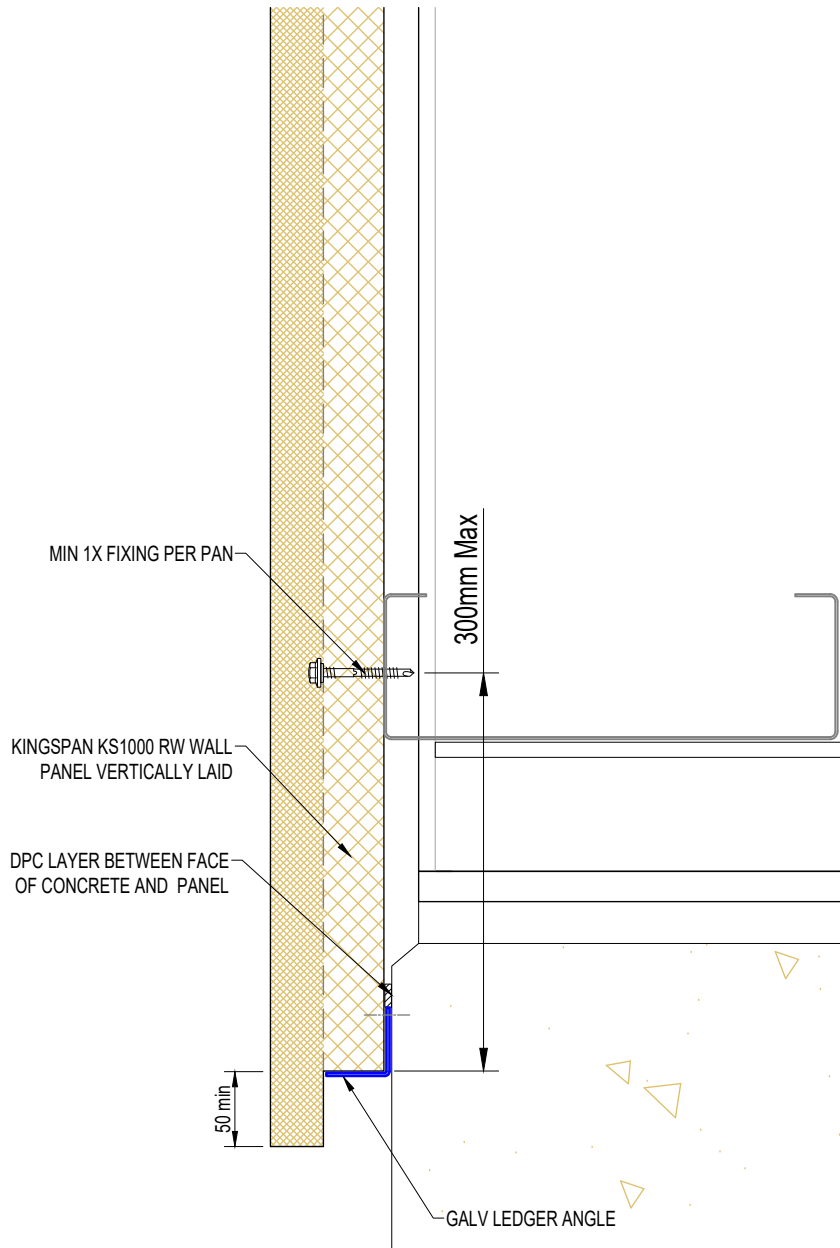

SYSTEM KS1000 RW WALL_VERTICAL Q4_2020.DWG			
DESCRIPTION BASE DETAILS 1			
APPROVED BY JS	DATE 24.09.20	REVISION -	
DRG REF: RW_VS_04	SCALE 1:5	SHEET 1 of 1	PAPER SIZE A4

This document remains the property of Kingspan Ltd under copyright laws. Licence is granted to use this document and its contents in connection with Kingspan Ltd products only.  
©Kingspan Ltd

DO NOT SCALE. IF IN DOUBT ASK

New Zealand: Kingspan Ltd  
97 Montreal St  
Christchurch  
Tel: 03 358 7536  
Fax: 03 358 7539  
Freephone: 0800 121280  
email: tech@kingspanpanels.co.nz  
www.kingspanpanels.co.nz



**Kingspan**  
Insulated Panels

# BASE DETAIL 2

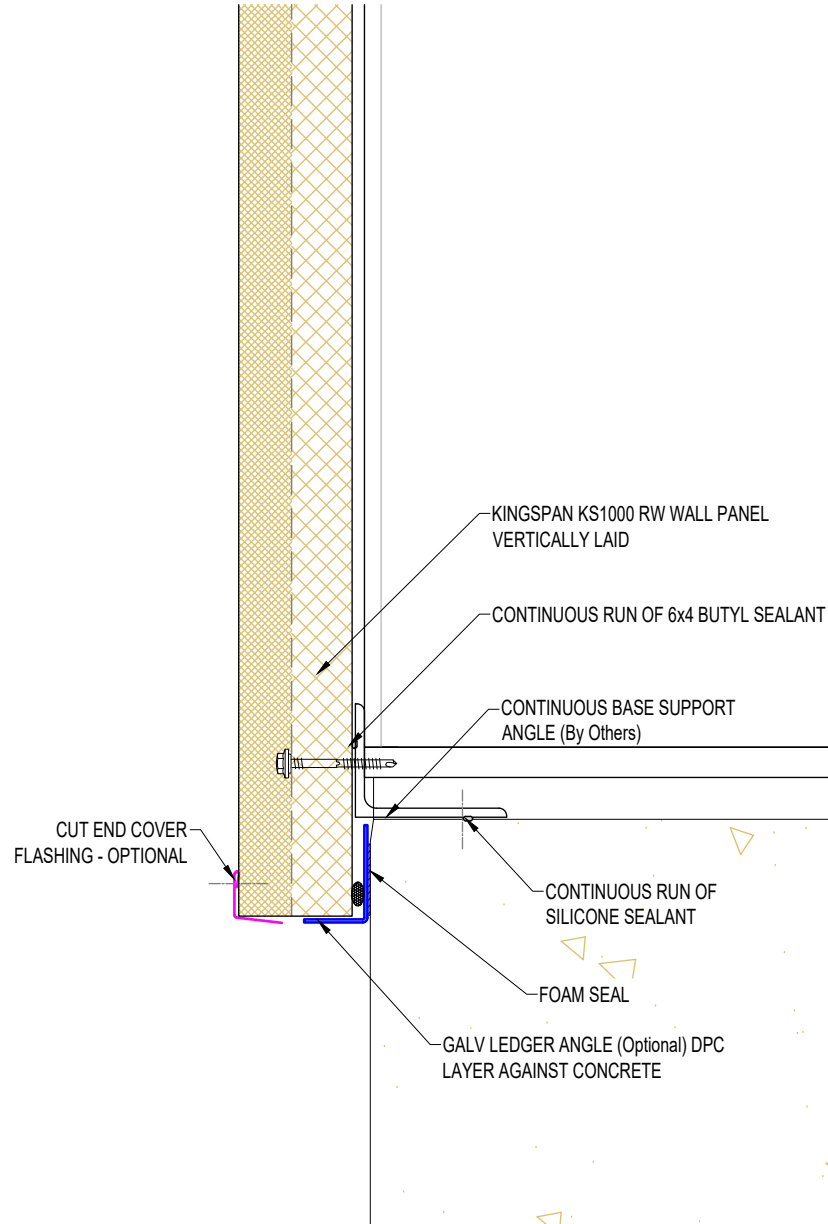
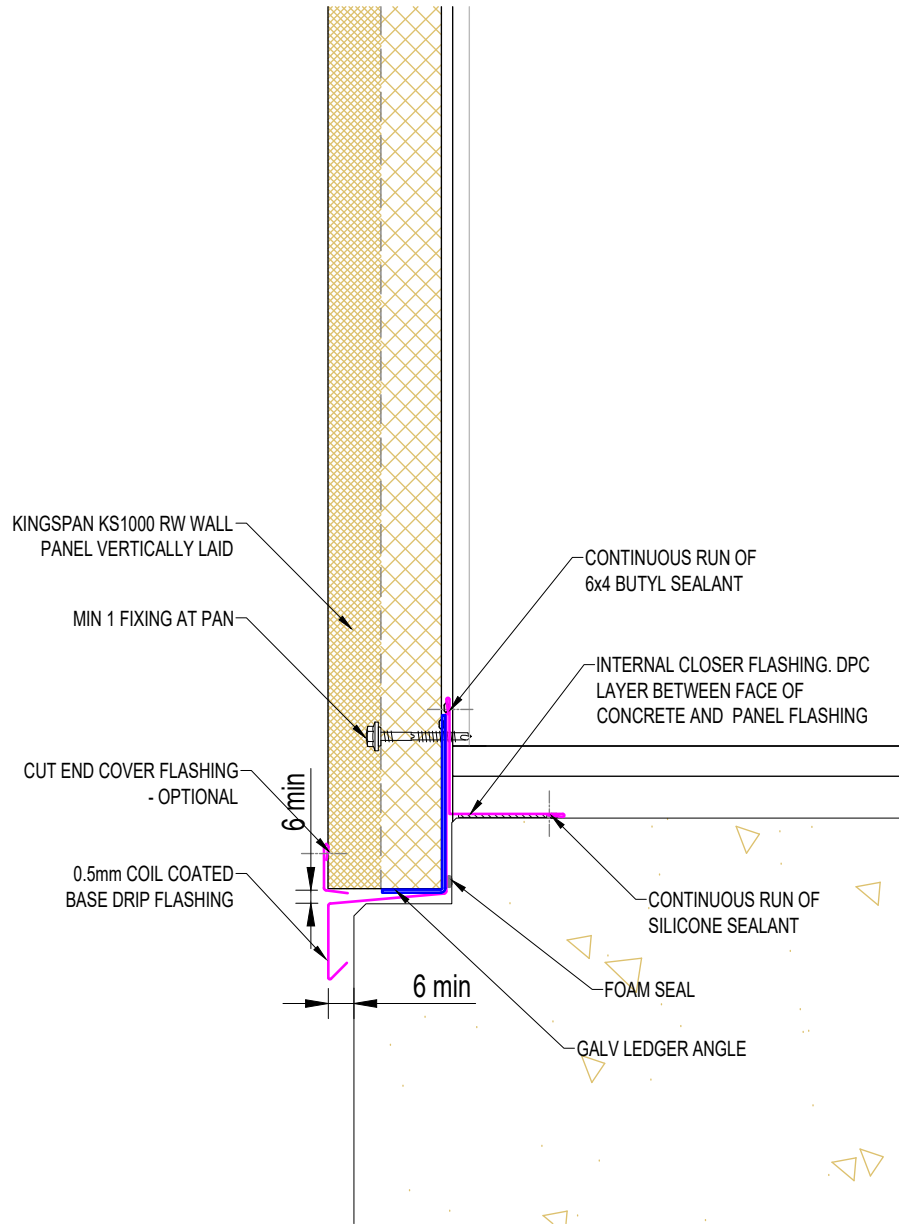

SYSTEM KS1000 RW WALL_VERTICAL Q4_2020.DWG			
DESCRIPTION BASE DETAIL 2			
APPROVED BY JS	DATE 24.09.20	REVISION -	
DRG REF: RW_VS_05	SCALE 1:5	SHEET 1 of 1	PAPER SIZE A4

This document remains the property of Kingspan Ltd under copyright laws. Licence is granted to use this document and its contents in connection with Kingspan Ltd products only.  
©Kingspan Ltd

DO NOT SCALE. IF IN DOUBT ASK

New Zealand: Kingspan Ltd  
 97 Montreal St  
 Christchurch  
 Tel: 03 358 7536  
 Fax: 03 358 7539  
 Freephone: 0800 121280  
 email: tech@kingspanpanels.co.nz  
 www.kingspanpanels.co.nz

# EXTERNAL CORNER

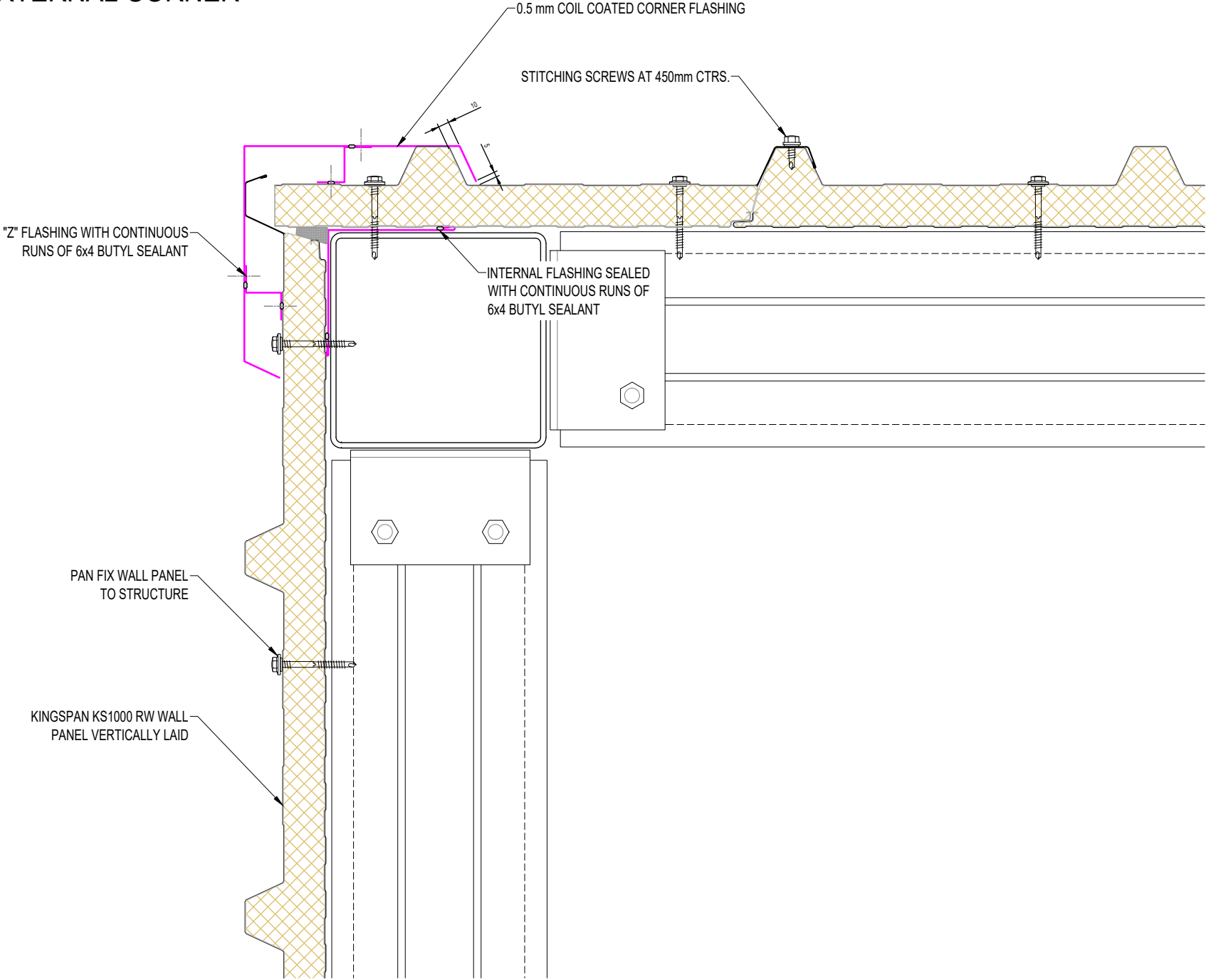

SYSTEM KS1000 RW WALL_VERTICAL Q4_2020.DWG			
DESCRIPTION EXTERNAL CORNER			
APPROVED BY JS	DATE 24.09.20	REVISION -	
DRG REF: RW_VS_06	SCALE 1:5	SHEET 1 of 1	PAPER SIZE A4

This document remains the property of Kingspan Ltd under copyright laws. Licence is granted to use this document and its contents in connection with Kingspan Ltd products only.  
©Kingspan Ltd

DO NOT SCALE. IF IN DOUBT ASK

New Zealand: Kingspan Ltd  
97 Montreal St  
Christchurch  
Tel: 03 358 7536  
Fax: 03 358 7539  
Freephone: 0800 121280  
email: tech@kingspanpanels.co.nz  
www.kingspanpanels.co.nz

# INTERNAL CORNER

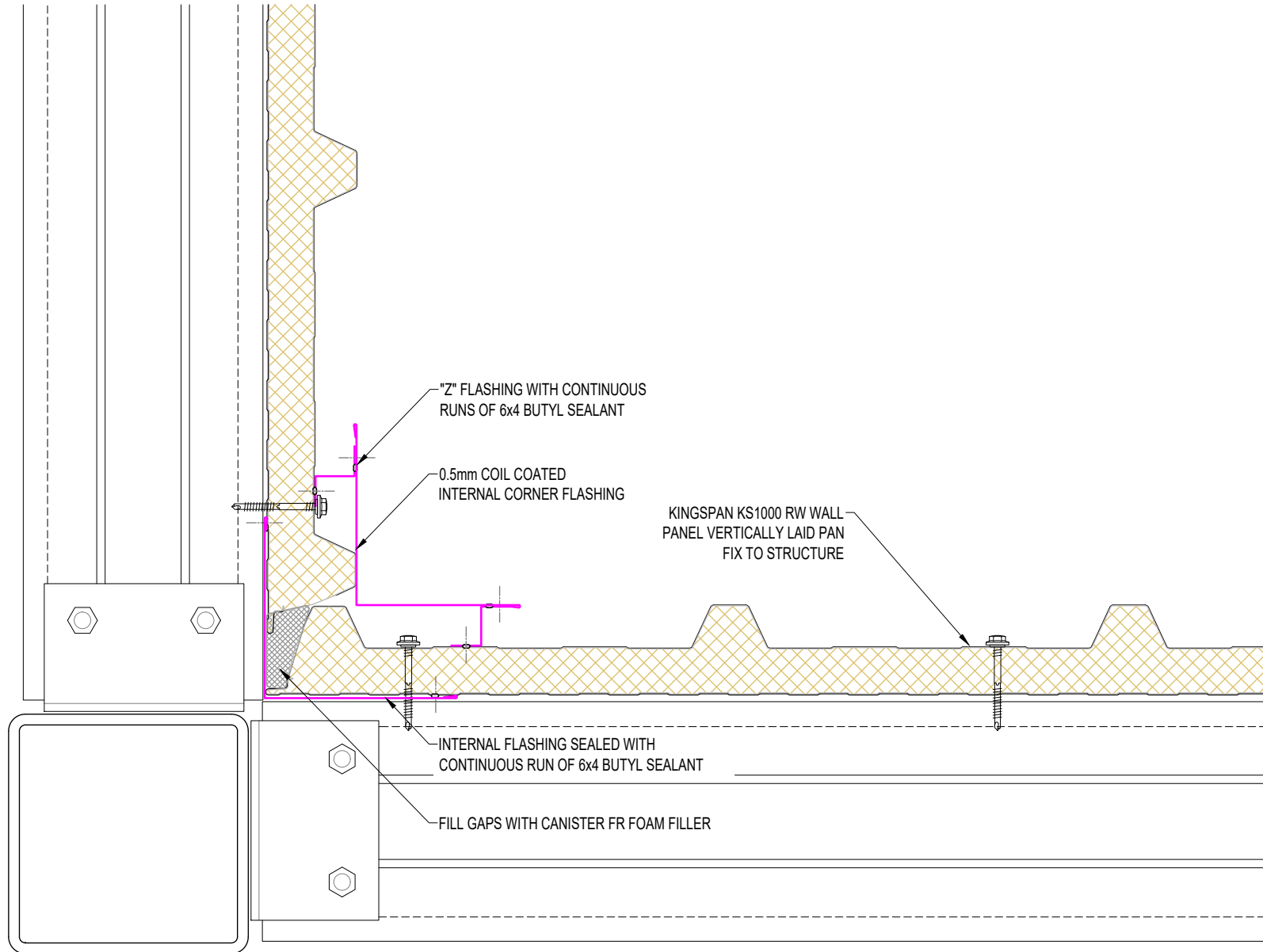

SYSTEM KS1000 RW WALL_VERTICAL Q4_2020.DWG			
DESCRIPTION INTERNAL CORNER			
APPROVED BY JS	DATE 24.09.20	REVISION -	
DRG REF: RW_VS_07	SCALE 1:5	SHEET 1 of 1	PAPER SIZE A4

This document remains the property of Kingspan Ltd under copyright laws. Licence is granted to use this document and its contents in connection with Kingspan Ltd products only.  
©Kingspan Ltd

DO NOT SCALE. IF IN DOUBT ASK

New Zealand: Kingspan Ltd  
97 Montreal St  
Christchurch  
Tel: 03 358 7536  
Fax: 03 358 7539  
Freephone: 0800 121280  
email: tech@kingspanpanels.co.nz  
www.kingspanpanels.co.nz



# ABUTMENT TO CONCRETE - FLUSH

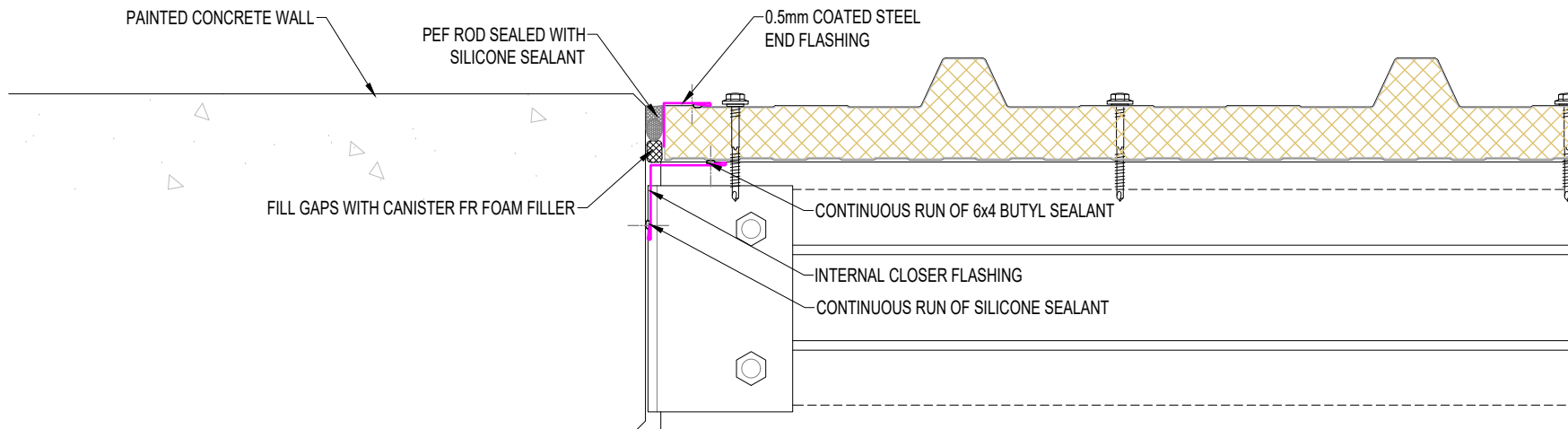
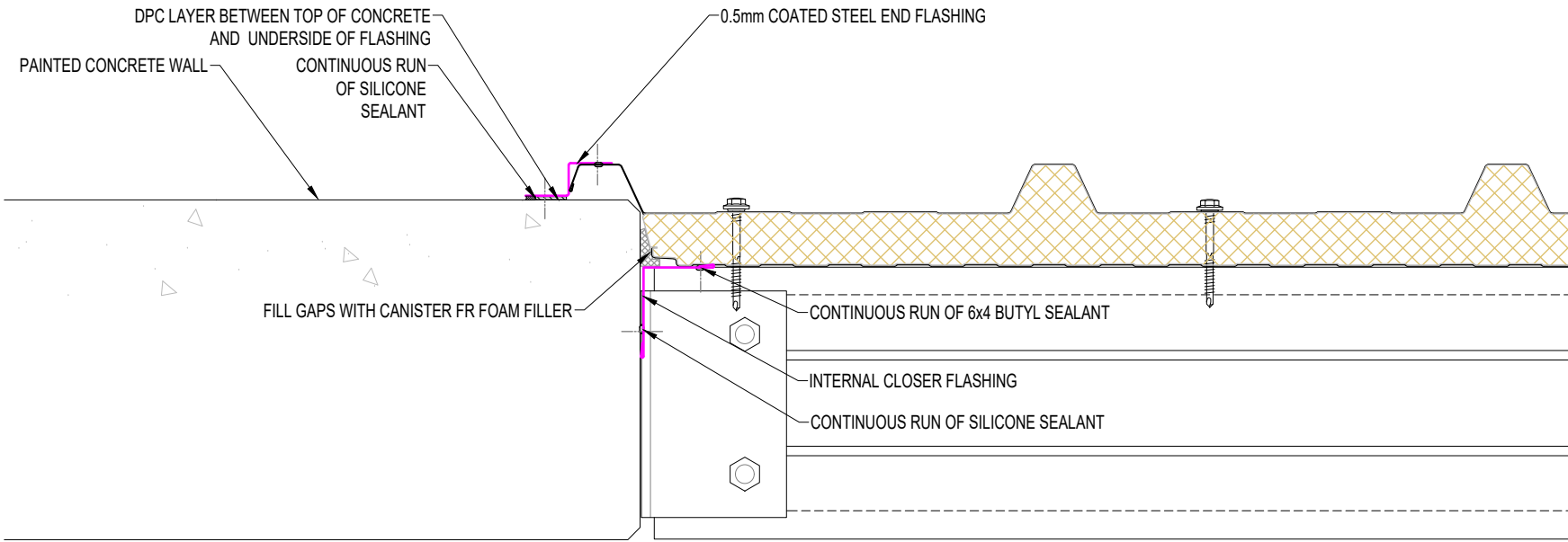

SYSTEM KS1000 RW WALL_VERTICAL Q4_2020.DWG			
DESCRIPTION ABUTMENT TO CONCRETE - FLUSH			
APPROVED BY JS	DATE 24.09.20	REVISION -	
DRG REF: RW_VS_08	SCALE 1:5	SHEET 1 of 1	PAPER SIZE A4

This document remains the property of Kingspan Ltd under copyright laws. Licence is granted to use this document and its contents in connection with Kingspan Ltd products only.  
©Kingspan Ltd

DO NOT SCALE. IF IN DOUBT ASK

New Zealand: Kingspan Ltd  
97 Montreal St  
Christchurch  
Tel: 03 358 7536  
Fax: 03 358 7539  
Freephone: 0800 121280  
email: tech@kingspanpanels.co.nz  
www.kingspanpanels.co.nz



# ABUTMENT TO CONCRETE - OVERHANG

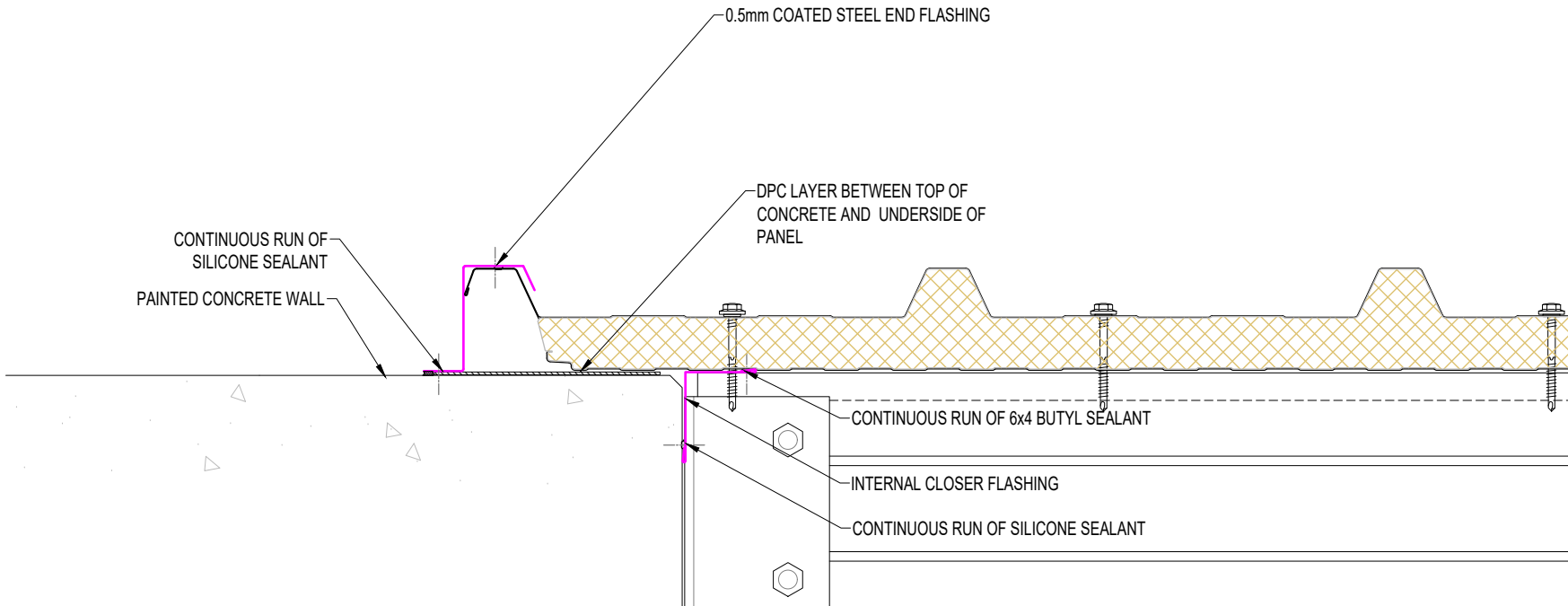
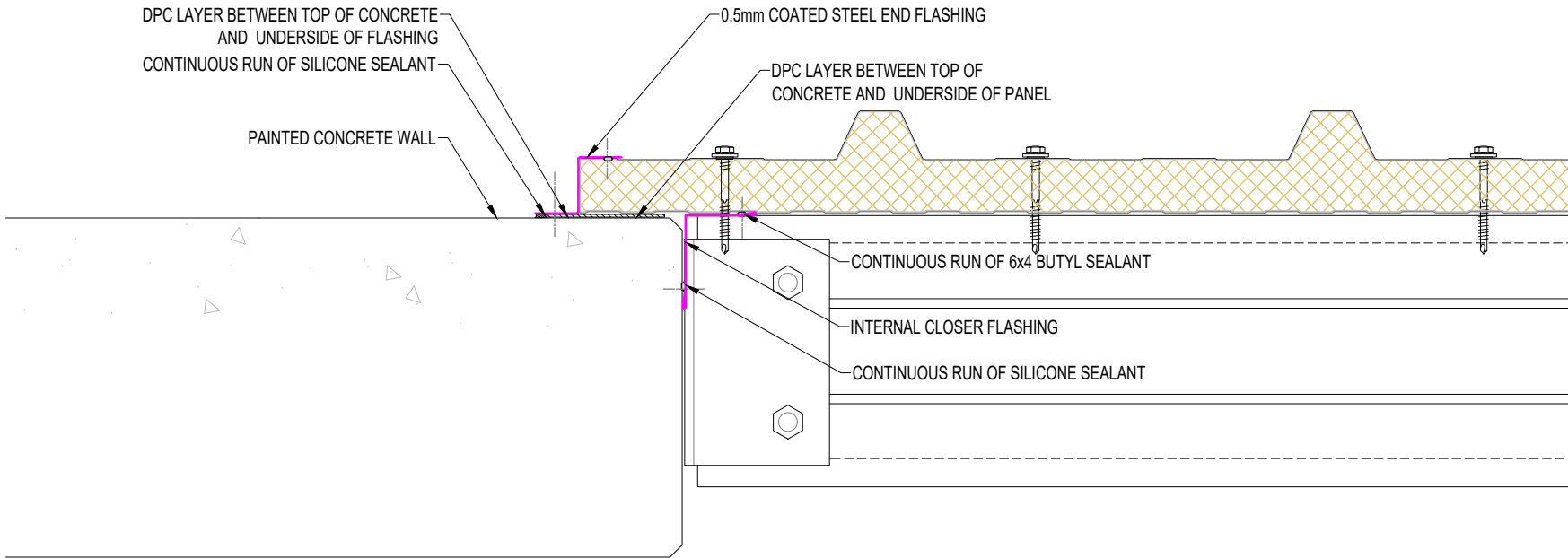

SYSTEM KS1000 RW WALL_VERTICAL Q4_2020.DWG			
DESCRIPTION ABUTMENT TO CONCRETE - OVERHANG			
APPROVED BY JS	DATE 24.09.20	REVISION -	
DRG REF: RW_VS_09	SCALE 1:5	SHEET 1 of 1	PAPER SIZE A4

This document remains the property of Kingspan Ltd under copyright laws. Licence is granted to use this document and its contents in connection with Kingspan Ltd products only.  
©Kingspan Ltd

DO NOT SCALE. IF IN DOUBT ASK

New Zealand: Kingspan Ltd  
97 Montreal St  
Christchurch  
Tel: 03 358 7536  
Fax: 03 358 7539  
Freephone: 0800 121280  
email: tech@kingspanpanels.co.nz  
www.kingspanpanels.co.nz



# VERTICAL TO HORIZONTAL BREAK DETAIL

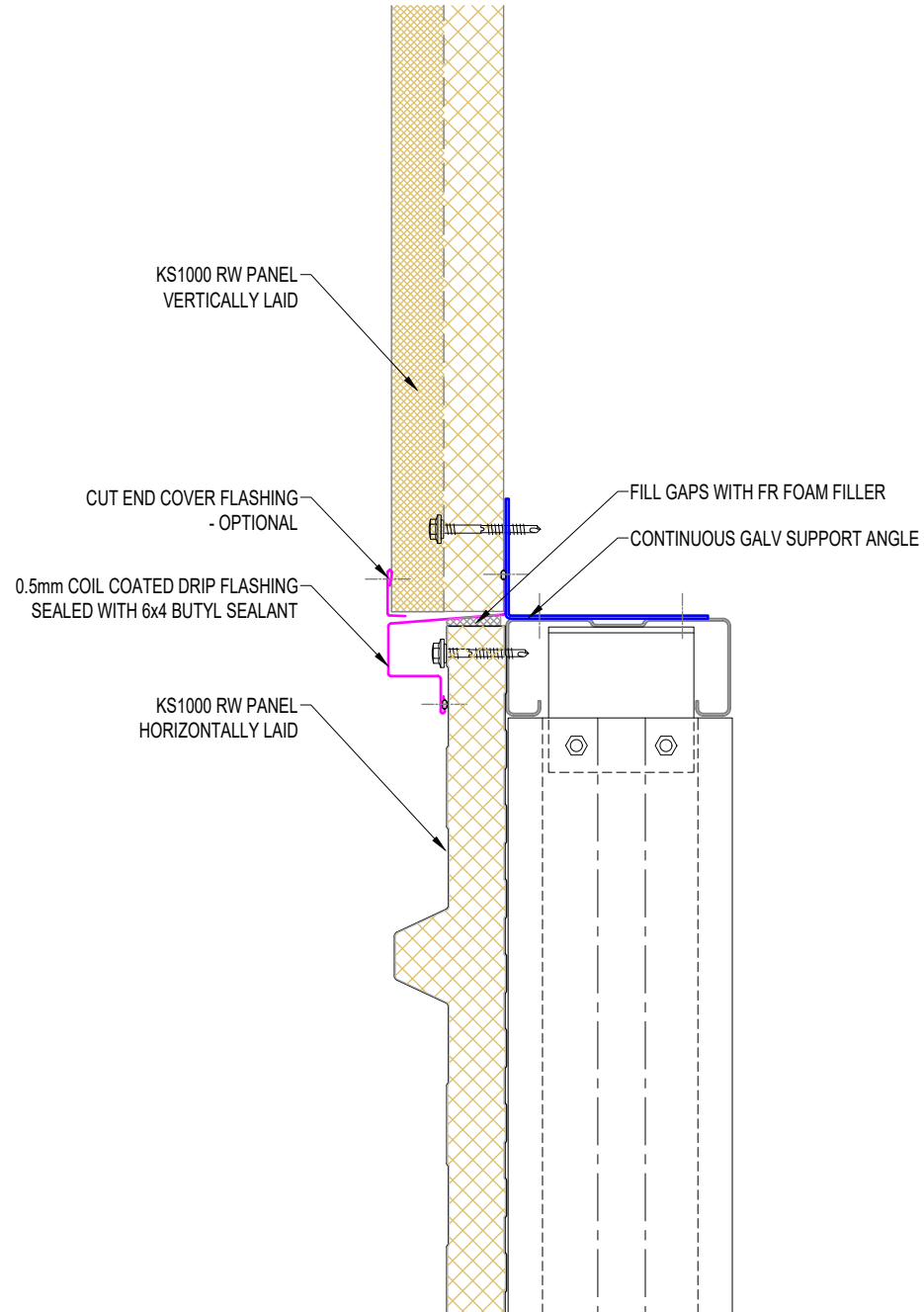

SYSTEM KS1000 RW WALL_VERTICAL Q4_2020.DWG			
DESCRIPTION VERTICAL TO HORIZONTAL BREAK DETAIL			
APPROVED BY JS	DATE 24.09.20	REVISION -	
DRG REF: RW_VS_10	SCALE 1:5	SHEET 1 of 1	PAPER SIZE A4

This document remains the property of Kingspan Ltd under copyright laws. Licence is granted to use this document and its contents in connection with Kingspan Ltd products only.  
©Kingspan Ltd

DO NOT SCALE. IF IN DOUBT ASK

New Zealand: Kingspan Ltd  
97 Montreal St  
Christchurch  
Tel: 03 358 7536  
Fax: 03 358 7539  
Freephone: 0800 121280  
email: tech@kingspanpanels.co.nz  
www.kingspanpanels.co.nz



# VERGE OVERHANG

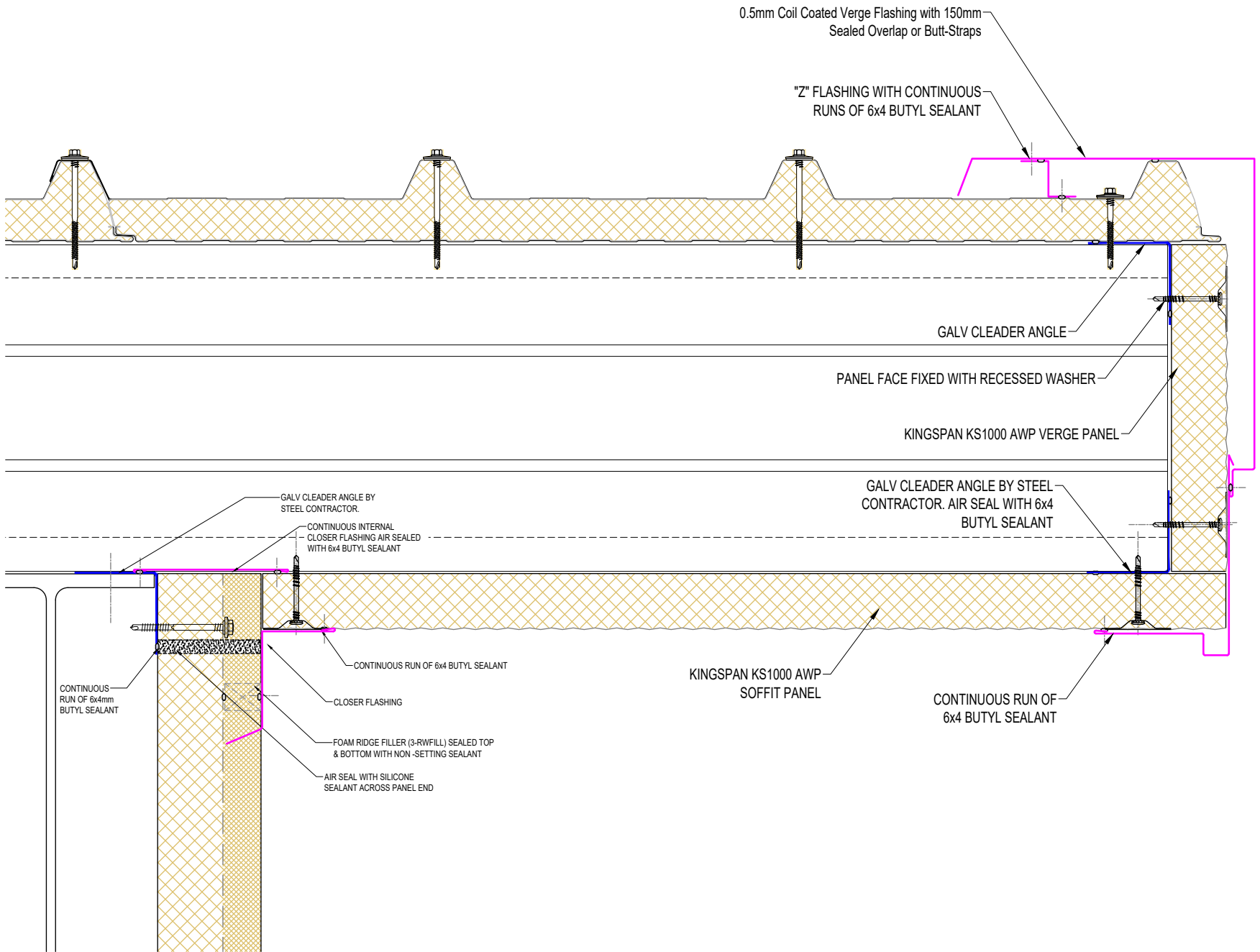

SYSTEM KS1000 RW WALL_VERTICAL Q4_2020.DWG			
DESCRIPTION VERGE OVERHANG			
APPROVED BY JS	DATE 24.09.20	REVISION -	
DRG REF: RW_VS_11	SCALE 1:2	SHEET 1 of 1	PAPER SIZE A4
This document remains the property of Kingspan Ltd under copyright laws. Licence is granted to use this document and its contents in connection with Kingspan Ltd products only. ©Kingspan Ltd			

DO NOT SCALE. IF IN DOUBT ASK

New Zealand: Kingspan Ltd  
97 Montreal St  
Christchurch  
Tel: 03 358 7536  
Fax: 03 358 7539  
Freephone: 0800 121280  
email: tech@kingspanpanels.co.nz  
www.kingspanpanels.co.nz

# WINDOW HEAD DETAIL

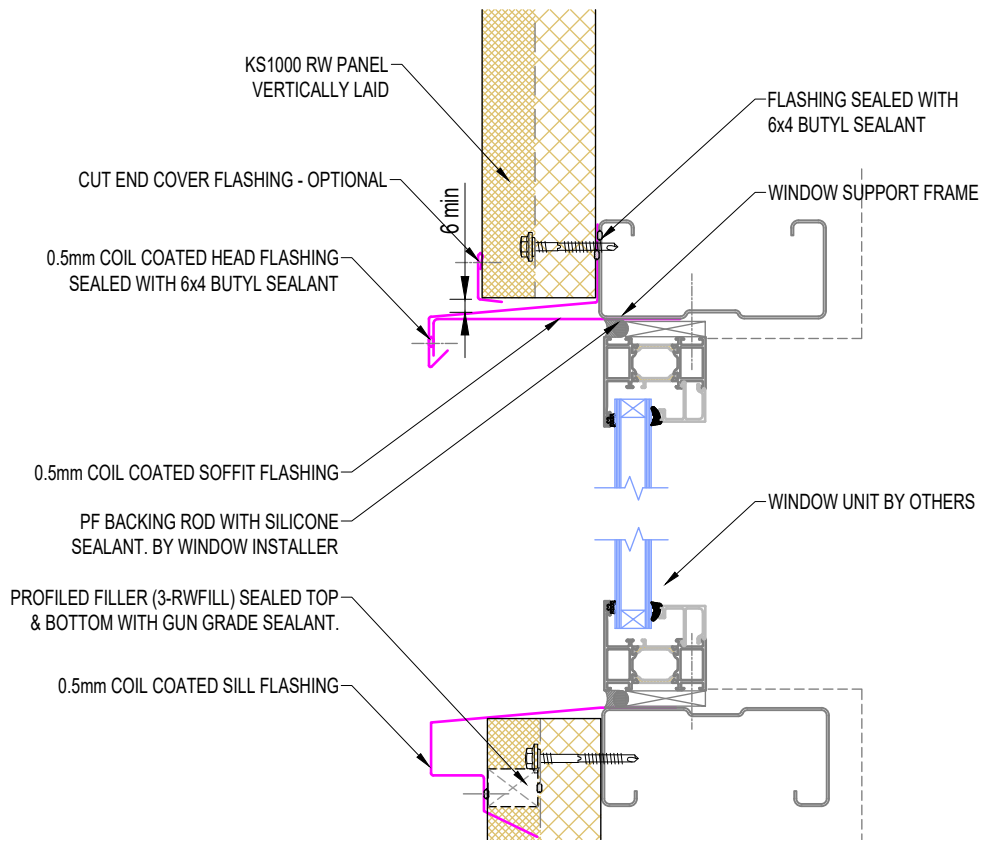
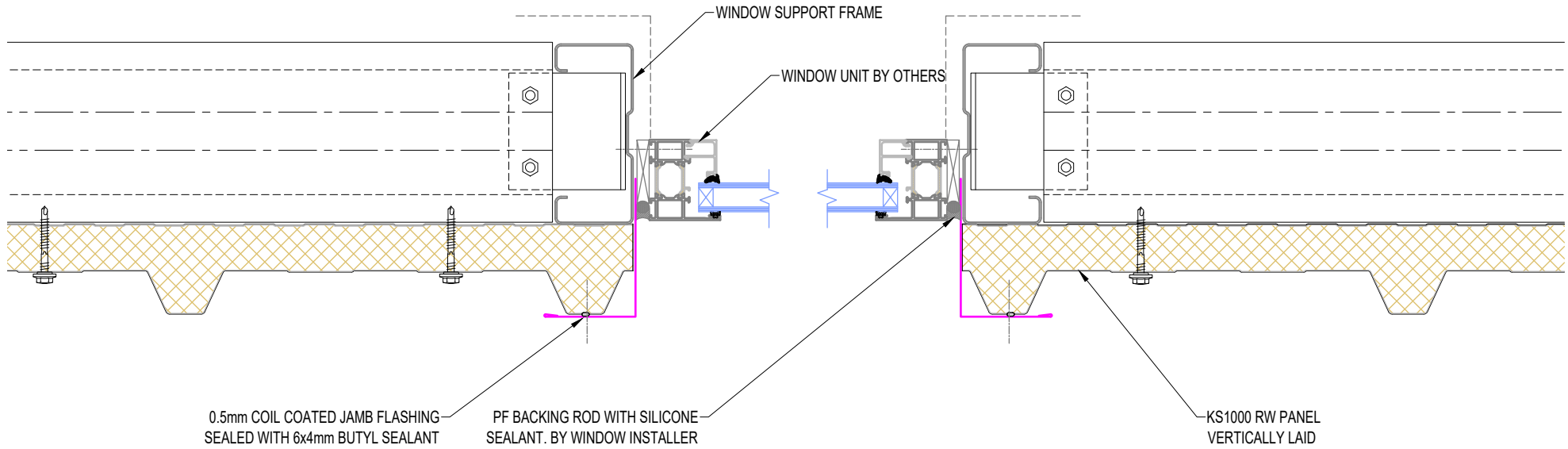

SYSTEM KS1000 RW WALL_VERTICAL Q4_2020.DWG			
DESCRIPTION WINDOW HEAD DETAIL			
APPROVED BY JS	DATE 24.09.20	REVISION -	
DRG REF: RW_VS_12	SCALE 1:5	SHEET 1 of 1	PAPER SIZE A4

This document remains the property of Kingspan Ltd under copyright laws. Licence is granted to use this document and its contents in connection with Kingspan Ltd products only.  
©Kingspan Ltd

DO NOT SCALE. IF IN DOUBT ASK

New Zealand: Kingspan Ltd  
 97 Montreal St  
 Christchurch  
 Tel: 03 358 7536  
 Fax: 03 358 7539  
 Freephone: 0800 121280  
 email: tech@kingspanpanels.co.nz  
 www.kingspanpanels.co.nz

# PERSONNEL DOOR DETAIL

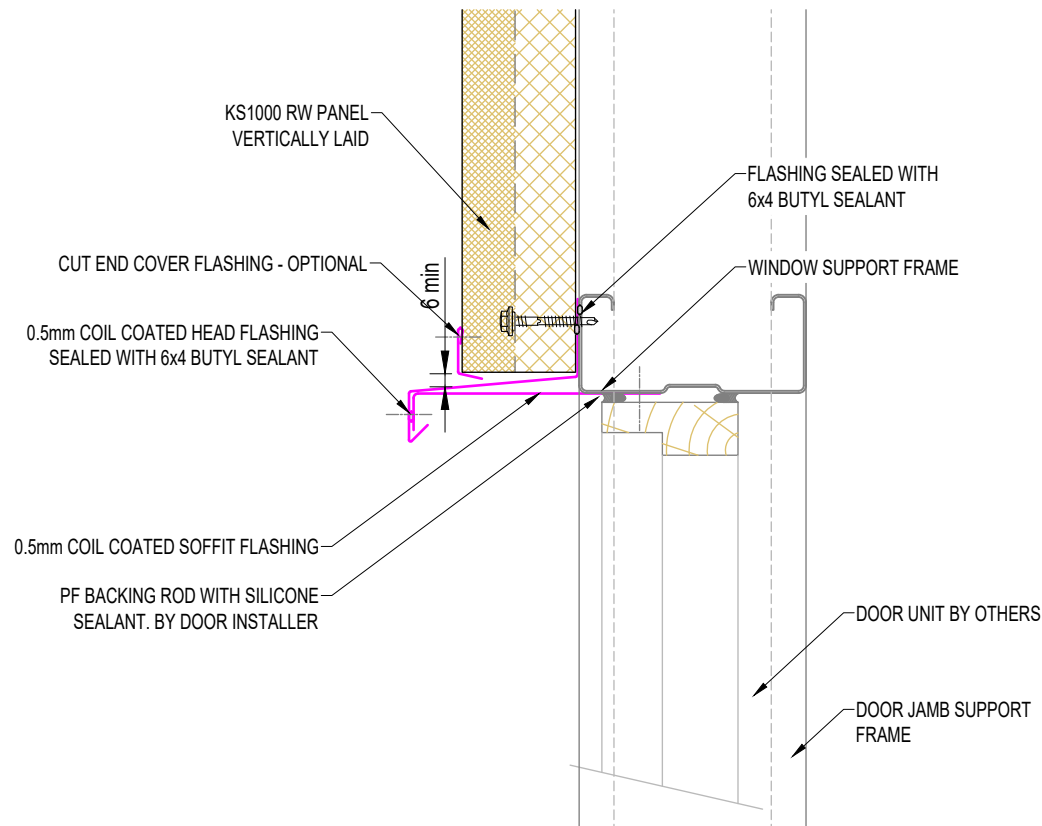
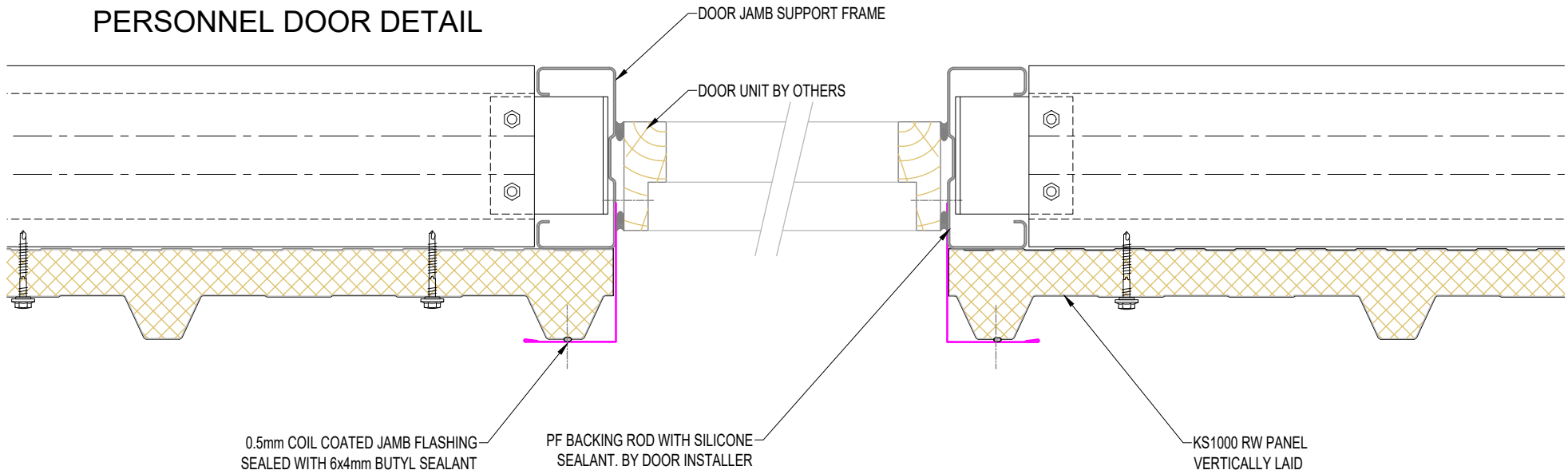

SYSTEM KS1000 RW WALL_VERTICAL Q4_2020.DWG			
DESCRIPTION PERSONNEL DOOR DETAIL			
APPROVED BY JS	DATE 24.09.20	REVISION -	
DRG REF: RW_VS_13	SCALE 1:5	SHEET 1 of 1	PAPER SIZE A4

This document remains the property of Kingspan Ltd under copyright laws. Licence is granted to use this document and its contents in connection with Kingspan Ltd products only.  
©Kingspan Ltd

DO NOT SCALE. IF IN DOUBT ASK

New Zealand: Kingspan Ltd  
97 Montreal St  
Christchurch  
Tel: 03 358 7536  
Fax: 03 358 7539  
Freephone: 0800 121280  
email: tech@kingspanpanels.co.nz  
www.kingspanpanels.co.nz

# OVERHEAD DOOR DETAIL

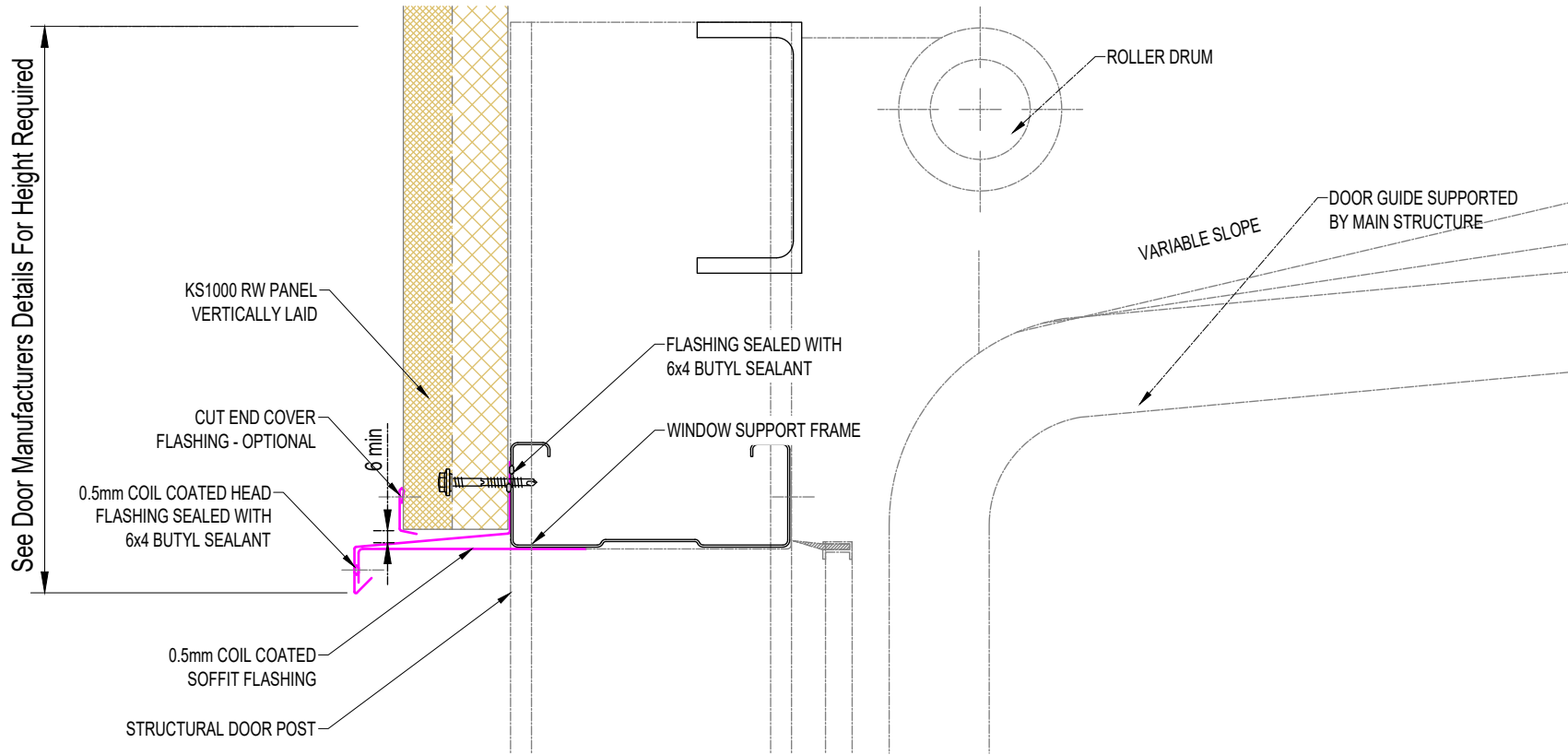
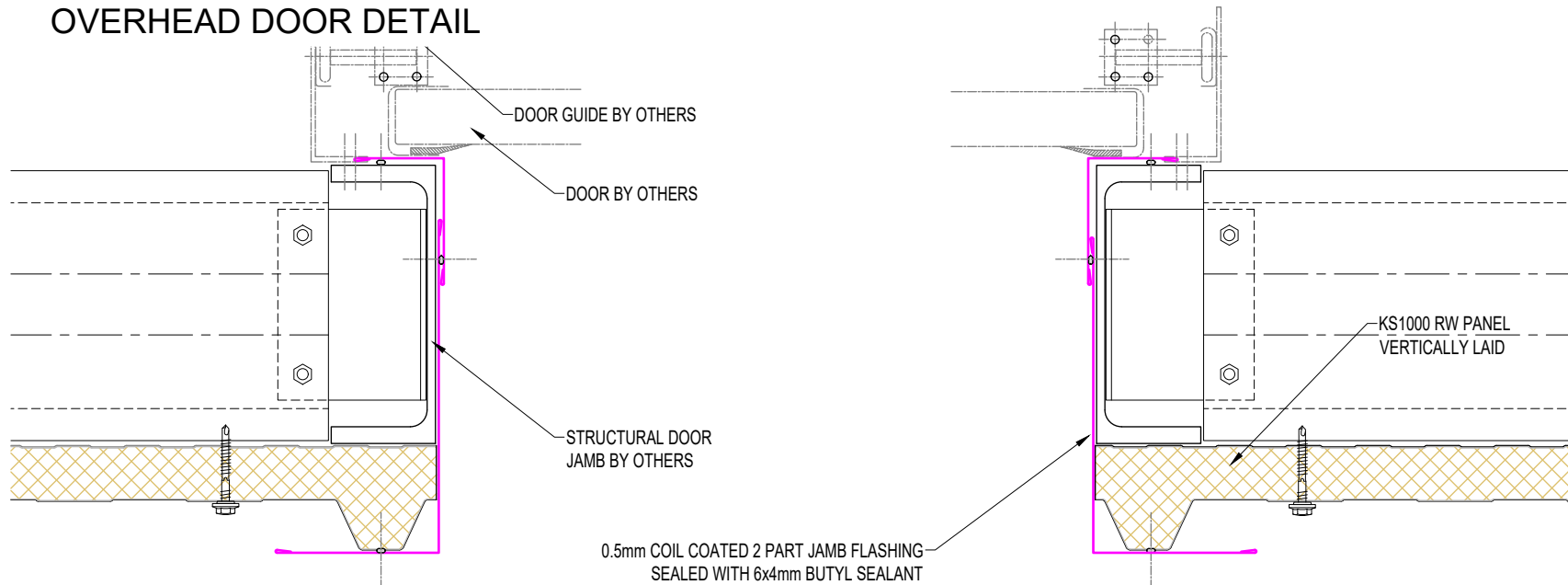

SYSTEM KS1000 RW WALL_VERTICAL Q4_2020.DWG			
DESCRIPTION OVERHEAD DOOR DETAIL			
APPROVED BY JS	DATE 24.09.20	REVISION -	
DRG REF: RW_VS_14	SCALE 1:5	SHEET 1 of 1	PAPER SIZE A4
This document remains the property of Kingspan Ltd under copyright laws. Licence is granted to use this document and its contents in connection with Kingspan Ltd products only. ©Kingspan Ltd			

DO NOT SCALE. IF IN DOUBT ASK

New Zealand: Kingspan Ltd  
 97 Montreal St  
 Christchurch  
 Tel: 03 358 7536  
 Fax: 03 358 7539  
 Freephone: 0800 121280  
 email: tech@kingspanpanels.co.nz  
 www.kingspanpanels.co.nz



# LOUVRE DETAIL

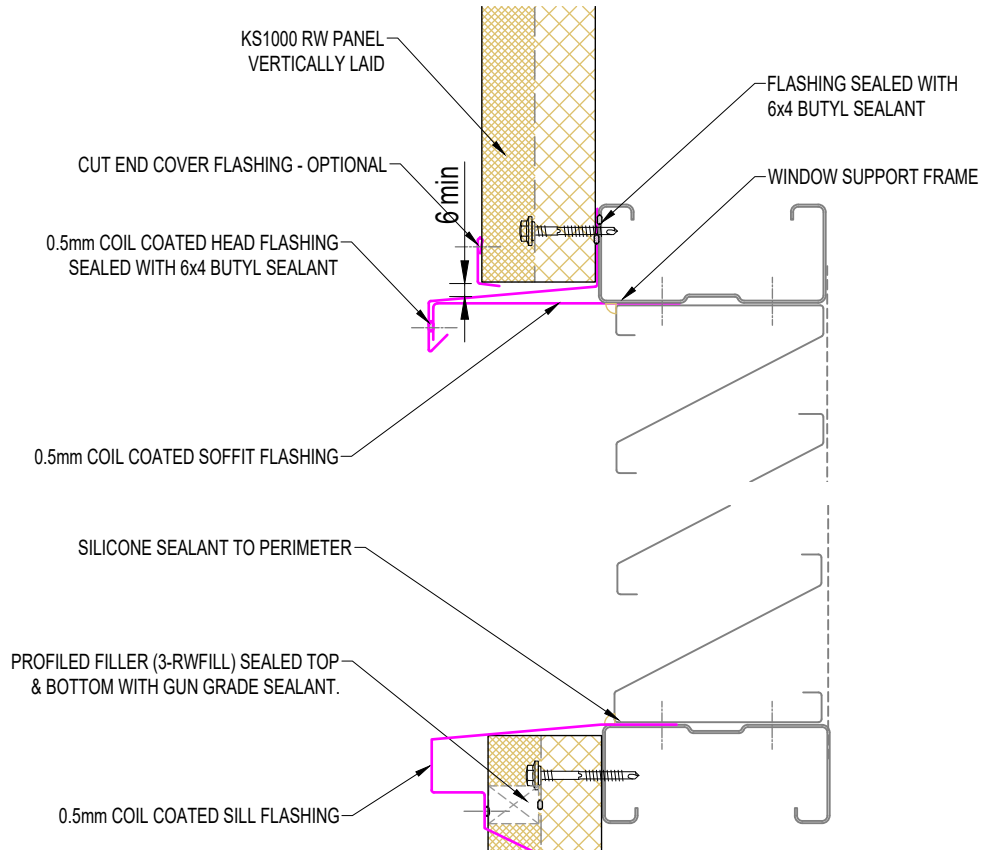
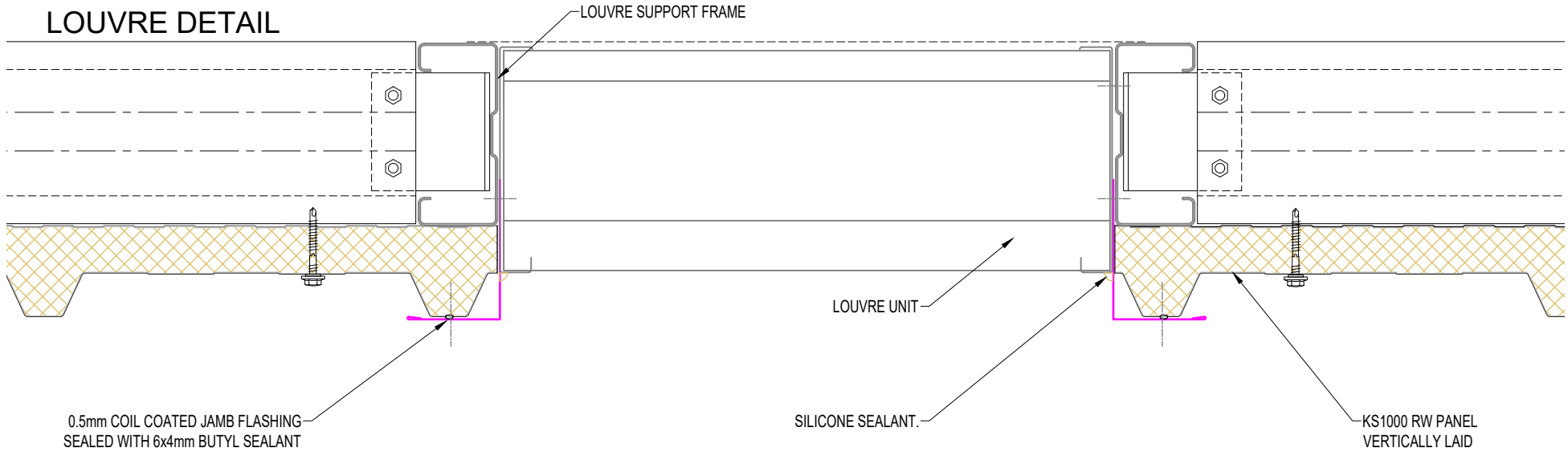

SYSTEM KS1000 RW WALL_VERTICAL Q4_2020.DWG			
DESCRIPTION LOUVRE DETAIL			
APPROVED BY JS	DATE 24.09.20	REVISION -	
DRG REF: RW_VS_15	SCALE 1:5	SHEET 1 of 1	PAPER SIZE A4

This document remains the property of Kingspan Ltd under copyright laws. Licence is granted to use this document and its contents in connection with Kingspan Ltd products only.  
©Kingspan Ltd

DO NOT SCALE. IF IN DOUBT ASK

New Zealand: Kingspan Ltd  
97 Montreal St  
Christchurch  
Tel: 03 358 7536  
Fax: 03 358 7539  
Freephone: 0800 121280  
email: tech@kingspanpanels.co.nz  
www.kingspanpanels.co.nz



# PIPE PENETRATION DETAIL

## STANDARD TEMPERATURE

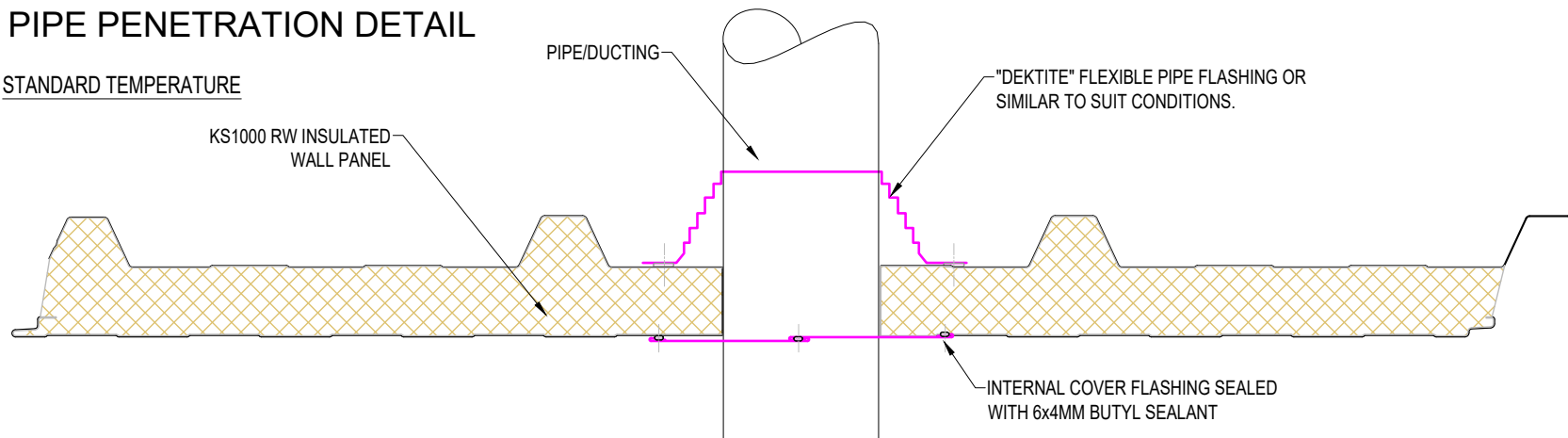

Note: Maximum circular hole size to be 300mm.  
Penetrations greater will require additional supporting steel.

## ALTERNATIVE STANDARD TEMPERATURE

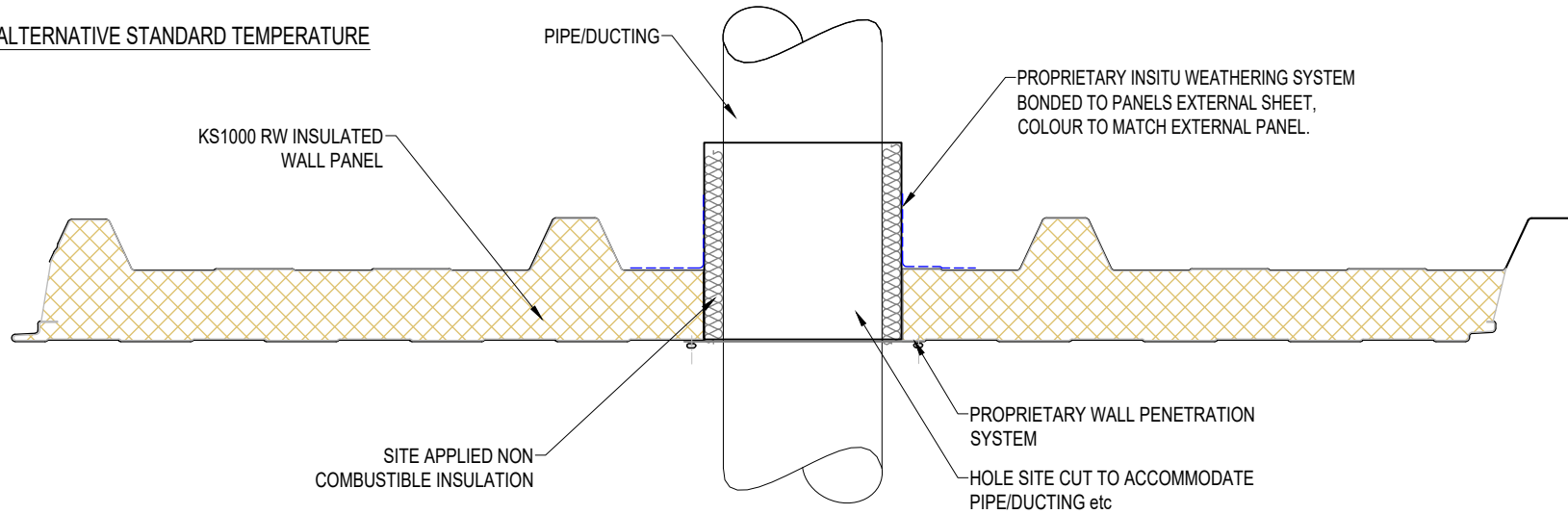

## HIGH TEMPERATURE

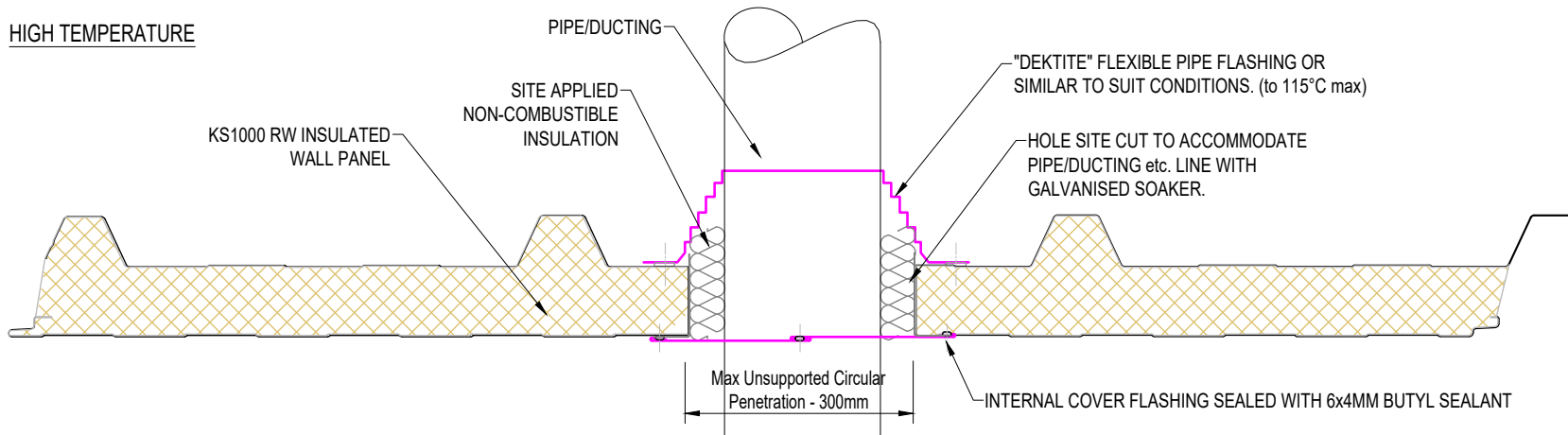

SYSTEM KS1000 RW WALL_VERTICAL Q4_2020.DWG			
DESCRIPTION PIPE PENETRATION DETAIL			
APPROVED BY JS	DATE 24.09.20	REVISION -	
DRG REF: RW_VS_16	SCALE 1:5	SHEET 1 of 1	PAPER SIZE A4
This document remains the property of Kingspan Ltd under copyright laws. Licence is granted to use this document and its contents in connection with Kingspan Ltd products only. ©Kingspan Ltd			

DO NOT SCALE. IF IN DOUBT ASK

New Zealand: Kingspan Ltd  
97 Montreal St  
Christchurch  
Tel: 03 358 7536  
Fax: 03 358 7539  
Freephone: 0800 121280  
email: tech@kingspanpanels.co.nz  
www.kingspanpanels.co.nz

# KS1100 CS GUTTER    KS1000 RW ROOF & VERTICAL WALL

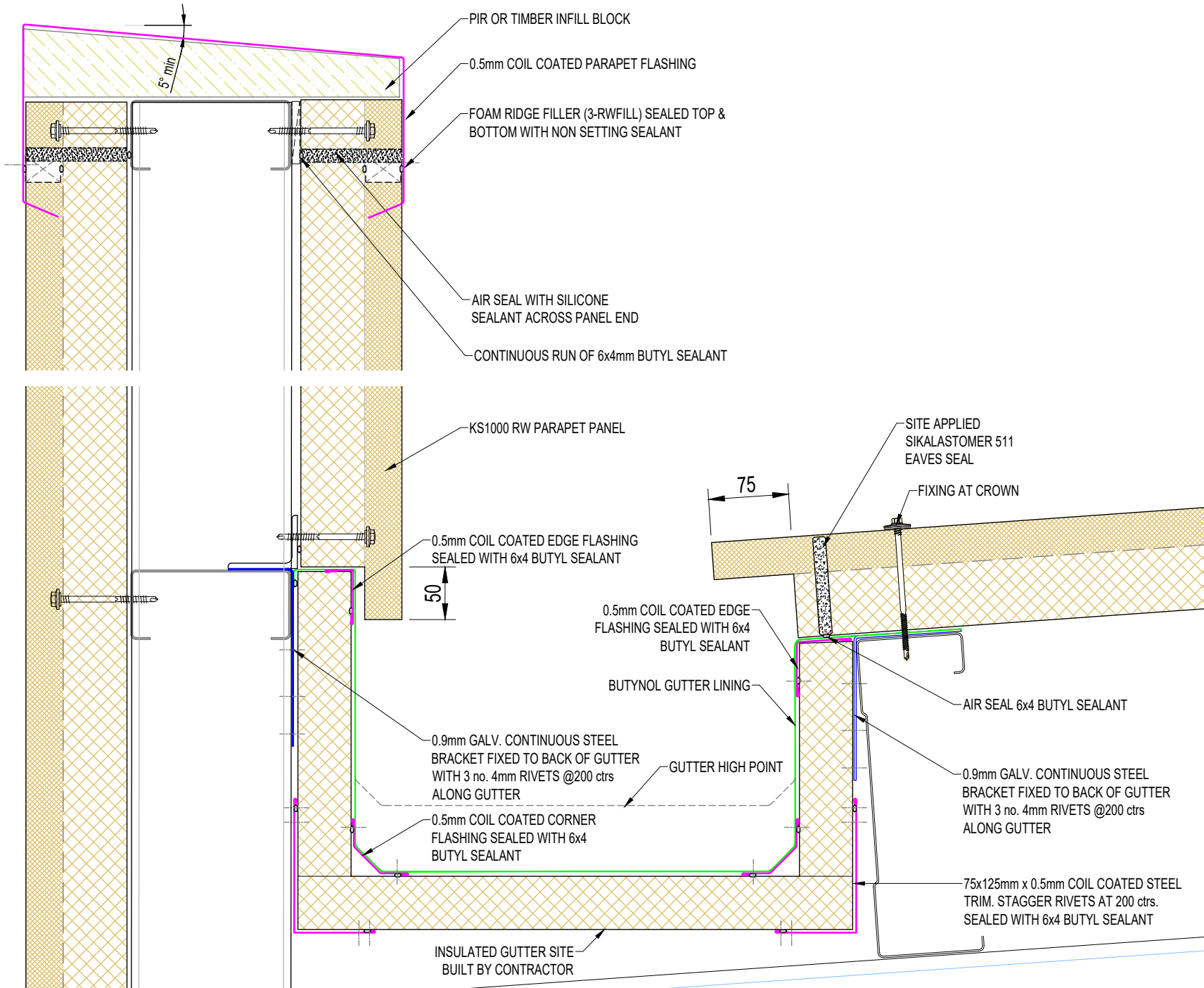

SYSTEM KS1000 RW WALL_VERTICAL Q4_2020.DWG			
DESCRIPTION KS1100 CS GUTTER    KS1000 RW ROOF & VERTICAL WALL			
APPROVED BY JS	DATE 24.09.20	REVISION -	
DRG REF: RW_VS_17	SCALE 1:5	SHEET 1 of 1	PAPER SIZE A4

This document remains the property of Kingspan Ltd under copyright laws. Licence is granted to use this document and its contents in connection with Kingspan Ltd products only.  
©Kingspan Ltd

DO NOT SCALE. IF IN DOUBT ASK

New Zealand: Kingspan Ltd  
97 Montreal St  
Christchurch  
Tel: 03 358 7536  
Fax: 03 358 7539  
Freephone: 0800 121280  
email: tech@kingspanpanels.co.nz  
www.kingspanpanels.co.nz

# EAVES GUTTER DETAIL

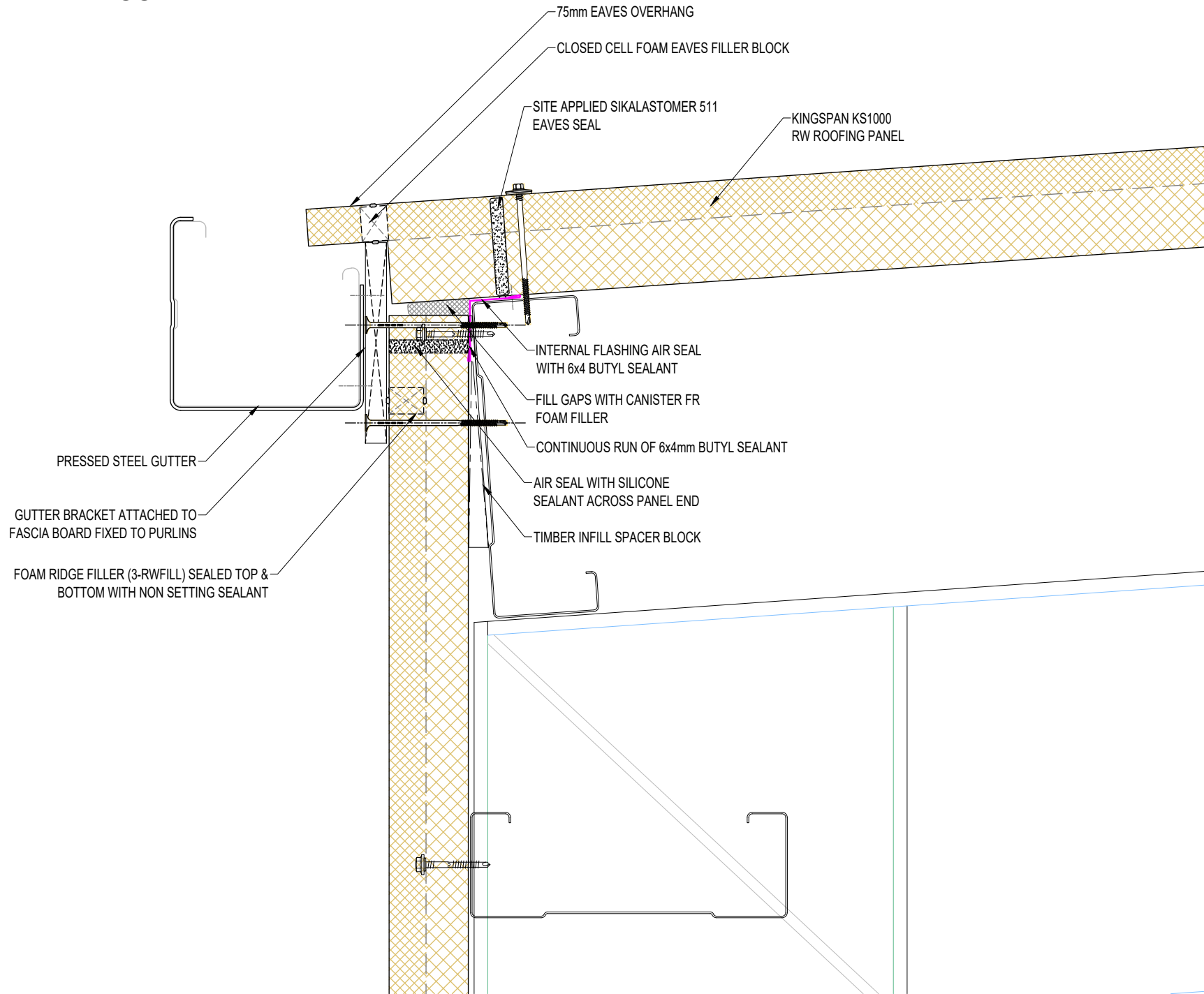

SYSTEM KS1000 RW WALL_VERTICAL Q4_2020.DWG			
DESCRIPTION EAVES GUTTER DETAIL			
APPROVED BY JS	DATE 24.09.20	REVISION -	
DRG REF: RW_VS_18	SCALE 1:5	SHEET 1 of 1	PAPER SIZE A4

This document remains the property of Kingspan Ltd under copyright laws. Licence is granted to use this document and its contents in connection with Kingspan Ltd products only.  
©Kingspan Ltd

DO NOT SCALE. IF IN DOUBT ASK

New Zealand: Kingspan Ltd  
97 Montreal St  
Christchurch  
Tel: 03 358 7536  
Fax: 03 358 7539  
Freephone: 0800 121280  
email: tech@kingspanpanels.co.nz  
www.kingspanpanels.co.nz

