

SAFETOR ROOF ANCHORS

... when your life is on the line!!

ANCHOR DEVICE : Reinforced Concrete Anchor

APPLICATION

This anchor can be used for any number of applications.:

Fall-arrest anchor	Scaffold anchor
Abseil anchor	Building tie down anchor
Lifeline anchor	Anchoring down Machinery
Access and Egress ladder anchor	



ULTIMATE YIELD: This anchor is rated for 21kN

DESIGN FEATURES

This anchor is designed to be tied to the reinforce steel set inside the concrete which makes it one of the strongest anchors on the market today and also gives this anchor a greater advantage over all other concrete anchors.

ADVANTAGES

1. Totally protected from the environment
2. Removable eye
3. Stronger connection on the building
4. Better suited in earthquake areas
5. Creates the best concrete anchor on the market
6. Eliminates the use of outriggers on scaffolding

APPLICATION AS PER AS/NZS 1891.4:2000

- Free fall arrests
- Abseil Anchors
- Lifeline Anchors

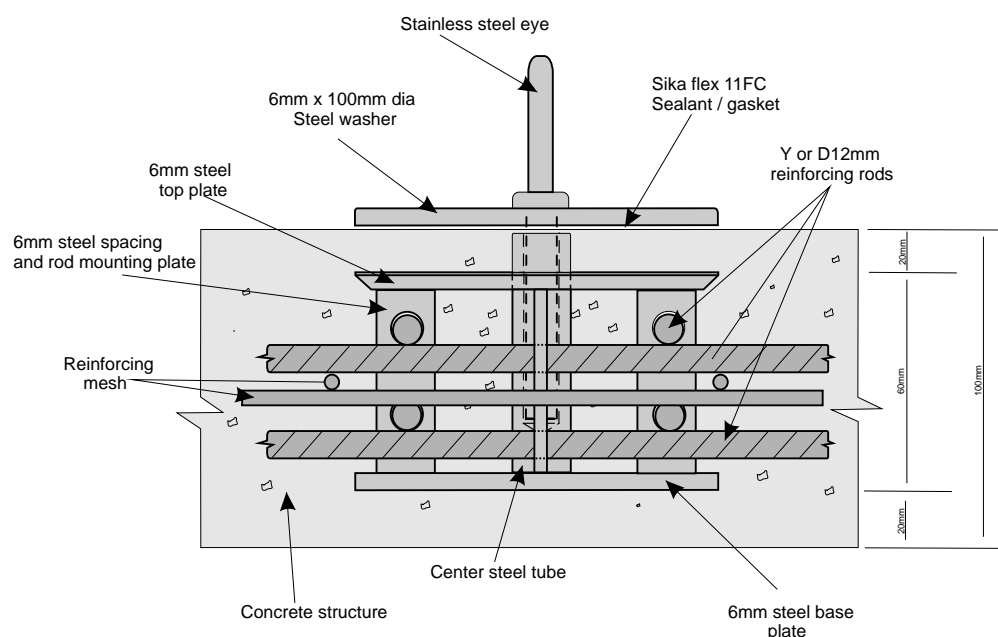

NB: Minimum concrete strength 25MPa