



Tyvek.

PROVIDING PROTECTION IN CONSTRUCTION

Volume 2: Walls and Floors

www.tyvek.co.uk
www.construction.tyvek.com



Tyvek® membranes wall and floor applications

Contents

	Page
Introduction	1
Wall products	2
Roofing products and AVCL's	3
DuPont Accessories	4
Product selector - Membrane applications	5
Membrane functions and suitability	6
Satisfying Building Regulations and Technical Standards	7
BBA Approvals	8
Wall applications (typical examples)	9
Installation in walls	10
DETAILING: Timber frame walls	11
DETAILING: Masonry walls	15
Tyvek® UV Facade installation	16
Tyvek® Reflex	18
Internal Lining: DuPont™ AirGuard® Reflective / DuPont™ AirGuard® Control / DuPont™ AirGuard® Smart	22
Timber Frame Wall Solutions for Part L and Scottish Technical Standard 6.....	26
Installation in suspended timber floors.....	28
Tyvek® membranes: Specification	30
Questions & Answers	33
Product Data	34
General notes	37
Technical support	37
Condensation risk analysis	38
British & European Standards	39
Regulations and Technical references	40
About DuPont	41
Contact Information	Back cover

Introduction

The DuPont™ Tyvek® family of membranes have been developed by DuPont to provide protection against the hazards associated with the construction and use of buildings; the principle hazards are:

- **climatic conditions** – rain, snow, hail, wind, ground moisture
- **condensation** – occurring on and within the building fabric

Protection in construction

Tyvek® membranes are engineered for the purposes of providing protection to buildings and their occupants from external climatic conditions and from the effects of condensation. This technical manual contains detailed information specifically on the use of Tyvek® membranes in **wall and floor construction**. By controlling the movements of heat, air and moisture through the building envelope Tyvek® membranes can make a major contribution to protecting the environment by improving the energy efficiency of buildings.

To achieve the required internal conditions with optimum efficiency it is essential to consider air flow and moisture movement together with all aspects of heat transfer, not only by conduction, but also by convection and radiation. The reduction of air leakage, the avoidance of damaging condensation and the provision of thermal insulation must all be considered together to ensure the protection and well-being of the occupants and the long term protection of the building fabric.

Fig. 1

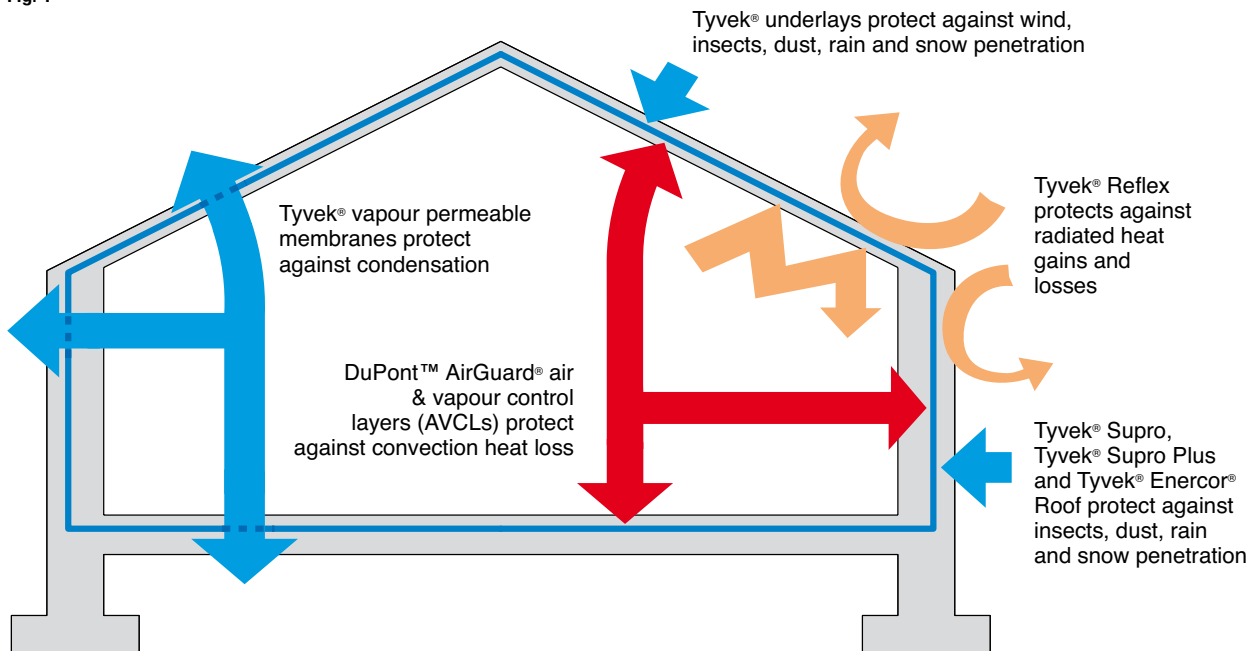

For information on Tyvek® membranes for protection against external moisture please contact:

01275 337660

DuPont™ Tyvek® product range and applications

Wall products



Tyvek® Housewrap

BBA certificate: No 90/2548

Highly water resistant and lightweight (61g/m²) vapour permeable membrane suitable for use as the secondary protection layer in timber frame, steel frame and concrete wall systems. Membrane should be surface applied, fixed directly to ply/OSB sheathing board, insulation or blockwork.

Roll sizes:

1.4 m x 100 m and 2.8 m x 100 m.

Horizontal lap: 100 mm.

Vertical lap: 150 mm.

Tyvek® Soft

A vapour open breather membrane with a functional layer being equal to product thickness. A microporous HD-PE flash-spun-bond product for use in timber frame applications.

Roll sizes:

1.4 m x 100 m and 2.7 m x 100 m.

Horizontal lap: 100 mm.

Vertical lap: 150 mm.

Tyvek® UV Facade

BRE certificate: 155/10

Black, UV resistant vapour permeable wall membrane for use behind open jointed cladding. Superior strength and water resistance provides excellent long term durability.

Roll size:

1.5 m x 50 m, 3.0 m x 50 m.

Tyvek® Reflex

BBA certificate: 90/2548

Tyvek® Reflex is a vapour open underlay with a metallised surface that reflects radiant heat in summer and helps to reduce heat loss in winter. It can be used in timber frame walls as well as metal frames, masonry and internal insulation upgrades.

Roll size:

1.50 m x 100 m, 2.70 m x 100 m,

2.40 m x 100 m, 0.48 m x 100 m.

Roofing products and AVCL's

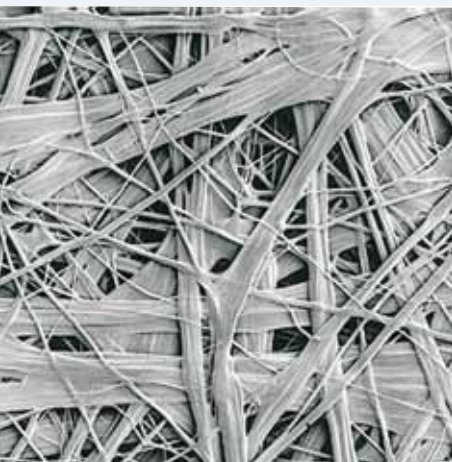

Tyvek® Supro

BBA certificate: o8/4548

Multi purpose, reinforced Tyvek® grade suitable for use in free-spanning wall applications where no supporting sheathing board exists. Also suitable for use as an insulation support in timber suspended floors and as a Tyvek LR pitched roof underlay in warm and cold roof systems.

Roll sizes:

1 m x 50 m and 1.5 m x 50 m.

Horizontal lap: 150 mm.

Tyvek® Supro Plus

BBA certificate: o8/4548

As **Tyvek® Supro** but with integral adhesive lap tape for use in the "Tyvek® sealed roof system". Sealing all horizontal laps will contribute to the system's thermal efficiency by reducing air infiltration.

Roll size: 1.5 m x 50 m.

Horizontal lap: 150 mm (sealed).

Tyvek® Metal

Metal roof breather membrane incorporating a supportive polypropylene drainage mesh for use beneath all rigid sheet metal roof systems. Allows condensate which can form beneath stainless steel, copper and zinc roofs to drain away. Membrane should be installed over softwood boarding. Integral lap tape provided.

Roll size: 1.5 m x 25 m.

Horizontal lap: 100 mm (sealed).

Tyvek® Enercor® Roof

A vapour open roof underlay with a metallised low emissivity surface, which blocks radiant heat in summer and reduces radiated heat loss in winter.

Roll size 1 m x 50 m.

NEW: DuPont™ AirGuard® Smart

A 100% airtight internal membrane, for roofs, walls and floors. Low vapour transmission resistance makes it an ideal component to achieve airtightness in the ceilings of cold pitched roofs to BS9250. Primary function is to reduce convective heat losses but also provides highly engineered vapour control for breathing systems.

Roll size: 1.5m x 50m.

DuPont™ AirGuard® Control

BBA certificates: o8/4548 and 90/2548

A 100% airtight vapour control layer (AVCL) with very high vapour resistance and low emissivity reflective surface. Ideally suited for warm roofs (pitched and flat) walls and floors. Significantly boosts thermal insulation in a building when used with a services void/batten space.

Roll sizes: 1.5 m x 50 m.

Lap: 100 mm.

DuPont™ AirGuard® Reflective

BBA certificate: o8/4548 and 90/2548

A 100% air tight vapour control layer featuring a metallised surface with a very low emissivity, which combined with a non-ventilated airspace significantly boosts thermal insulation in a building.

Roll size: 1.5 m x 50 m.

Tyvek® Eaves Carrier

Pre-formed black semi-rigid eaves protection sheet installed over the fascia board under lapping the Tyvek® membrane by 150 mm.

Recommended for long term durability against UV degradation from direct sunlight whilst offering support to the membrane to eliminate ponding at the tilt position.

Sheet size: 220 mm x 1.3 m.

Vertical lap: 100 mm.

DuPont™ Tyvek® product range and applications

DuPont accessories

Tyvek® Acrylic Tape

Single-sided tape for sealing overlaps and making good around penetrations, pipes and windows. Recommended for DuPont™ AirGuard® Control, but suitable for all Tyvek® membranes. Made of Tyvek® and acrylic adhesive for durable and long lasting bonding.

Roll size: 75mm x 25m.

Tyvek® Butyl Tape

Double sided butyl based sealant, used to form a moisture and airtight seal between a Tyvek® membrane and most commonly used building materials. The product is compatible with brickwork, blockwork, masonry, timber, metalwork and most plastic products. Tyvek® Butyl Tape is most effective when used under compression, eg. under a timber batten and is recommended for use at perimeters, chimneys, abutments and for sealing nail penetrations and around electrical sockets.

Roll sizes: 20mm x 30m and 50mm x 30m.

Tyvek® Metallised Tape

Single-sided reflective tape for sealing laps in Tyvek® Enercor® Roof and Tyvek® Reflex and DuPont™ AirGuard® Reflective. Ideal for making good around penetrations, pipework, windows and doors. Made of metallised Tyvek® and acrylic adhesive. Provides durable and long-lasting bond once cured.

Roll size: 75mm x 25m.

Tyvek® Double-sided Tape

Double-sided acrylic tape ideal for sealing overlaps and bonding Tyvek® membranes to smooth surfaces. Excellent adhesion properties under extreme humidity conditions. Strong initial tack. Recommended for Tyvek® UV Facade, but suitable for all Tyvek® membranes.

Roll size: 50mm x 25m.

DuPont™ FlexWrap NF

DuPont™ FlexWrap NF is a stretchable and flexible tape made up of 3 components: a crimped DuPont™ Tyvek® top sheet providing a water tight layer, the butyl mass as an adhesion layer and a paper release liner. It provides excellent watertight adhesion to all Tyvek® breather membranes around non-straight penetrations, such as dormers, door sills, chimney breasts, pipe penetrations and any custom shapes.

Roll size: 150mm x 22.9m

Tyvek® UV Facade Tape

Black single sided acrylic tape with high UV resistance. Especially designed for sealing Tyvek® UV Facade overlaps, penetration and joints in a durable and non-contrasting manner. Excellent aging and outdoor performance.

Roll size: 75mm x 25m.

Advice note: Cold and/or wet conditions can affect the bonding performance of adhesive tapes generally. If in doubt or for general guidance please contact Tyvek® Technical on 01275 337660.

Product selector membrane applications Fig. 2

Tyvek® Grade	Warm Pitched Roofs	Cold Pitched Roofs	Metal Clad Industrial Roofs	Scottish boarded Roofs	Walls	Suspended timber floors
Tyvek® Supro	•	•	•	•	•	•
Tyvek® Supro Plus	•	•	•	•	•	•
Tyvek® Metal			•			
Tyvek® Enercor® Roof	•	•	•	•		
Tyvek® Housewrap					•	
Tyvek® Soft					•	
Tyvek® Reflex					•	
Tyvek® UV Facade					•	
DuPont™ AirGuard® Smart	•	•	•	•	•	•
DuPont™ AirGuard® Control	•	•	•	•	•	•
DuPont™ AirGuard® Reflective	•	•	•	•	•	•

Please note: DuPont™ AirGuard® Control, Smart and DuPont™ AirGuard® Reflective are for internal use only

Tyvek® membranes - Wall and floor applications

All Tyvek® membranes and ancillary products for use in roof and wall applications available in the Tyvek® construction membrane range are listed here. However, Tyvek® membranes used in pitched roof applications are covered in a separate technical manual.

Tyvek® membranes wall and floor applications

Wall membrane

Tyvek® Housewrap, Tyvek® UV Facade, Tyvek® Soft and Tyvek® Reflex are lightweight flexible sheet materials suitable for use as breather membranes in most forms of wall construction. Manufactured from high density polyethylene or polypropylene Tyvek® membranes are extremely durable and may be incorporated into new-build, refurbishment or extension projects.

Timber frame wall construction

All Tyvek® wall membranes more than satisfy the requirements for a Type 1 breather membrane as defined in BS 4016 and achieve W1 underlay classification to EN 13859. The water resistance, strength and vapour permeable characteristics of the membranes make them suitable for use as breather membranes in timber frame walls as defined by TRADA Wood Information Sheet 1-35.

In timber frame wall constructions a breather membrane must be 'vapour open' so as to allow water vapour to pass through to outside atmosphere whilst at the same time be water-resistant. The functions of a breather membrane are summarized by TRADA in the following bullet points:

- It protects the fabric of the building from rainwater penetration during construction before external claddings are completed.
- *It provides a second line of defence against water penetration during the life of the building as most claddings act as rainscreens, rather than as complete barriers.*

- *It allows water vapour to escape from the construction.*
- *It can also contribute to air sealing the wall and reduce ventilation heat losses. This aspect is likely to be of increasing importance as air leakage becomes more significant in thermal performance requirements under building regulations.*

These points represent the basic functions of a breather membrane. Tyvek® wall membranes will satisfy all of these requirements and have exceptional strength and durability.

Tyvek® membranes are suitable materials for use as breather membranes in timber frame walls.

Other forms of wall construction

There are many other forms of wall construction, some of which may also benefit from the inclusion of a breather membrane. These can include metal frame, brick and block, stone, masonry and rainscreen cladding systems. The use of a breather membrane would be particularly advantageous if the building is to be constructed in a very exposed location.

The various forms of wall constructions where Tyvek® membranes can be used are shown on page 9.

Installation guidance is given on pages 10-15.

Floor constructions

Tyvek® membranes may also be installed into suspended timber floor constructions, providing a method of support to insulation as well as offering protection against external moisture, condensation and air infiltration.

Installation guidance for the use of Tyvek® membranes in floor constructions is given on pages 28 & 29.

Airtightness

Wall constructions and suspended timber floors should be designed so that the risk of harmful condensation occurring is minimized. This can be achieved by allowing moisture laden air to escape from the construction via natural air movement or ventilation to external airspaces. However, air infiltration through gaps in the building fabric can accelerate the rate of heat loss due to convection and so reduce thermal performance. Where airtightness is required the breather membrane can contribute greatly, particularly when all laps are sealed with adhesive tape.

Achieving airtightness is equally important in both wall and floor construction.



Satisfying the Building Regulations

Approved Documents contain practical guidance on how to meet the requirements of *The Building Regulations* for England and Wales. The requirements of the *Building Standards (Scotland) Regulations* are set out in Technical Standards. The requirements for both regions are very similar:

England and Wales

Approved Document C covers Resistance to moisture under C2. The requirement is set out as follows:

Resistance to moisture C2.

The floors, walls and roof of the building shall adequately protect the building and people who use the building from harmful effects caused by:

- (a) ground moisture;
- (b) precipitation and wind driven spray;
- (c) interstitial and surface condensation;
- (d) spillage of water from or associated with sanitary fittings or fixed appliances.

Tyvek® membranes will help to achieve compliance with Approved Document C2 (items a, b and c).

Scotland

Guidance on how to achieve compliance with the Building (Scotland) Regulations is set out in two Technical Handbooks covering **Domestic** and **Non-Domestic** building types. The handbooks are divided into several sections and cover a number of related standards.

The requirements of a wall system and its resistance to external moisture and condensation are set out under Section

3:Environment.

Clause 3.10 relates to Precipitation **(G3.1)** and is common to both domestic and non-domestic buildings:

3.10.1 Precipitation (General Provisions)

A floor, wall, roof or other building element exposed to precipitation, or wind driven moisture, should prevent penetration of moisture to the inner surface of any part of a building/dwelling so as to protect the occupants and to ensure that the building is not damaged.

Clause 3.15 relates to Condensation **(G4.1, G4.2)** and is common only to domestic buildings:

3.15.4 Interstitial condensation (G4.1)

A floor, wall, roof or other building element should minimize the risk of interstitial condensation in any part of a dwelling that it could damage.

Tyvek® membranes will help to achieve compliance with Sections 3.10 and 3.15 (G3.1 and G4.1) of the Scottish Building Standards.

The installation of a Tyvek® membrane will offer protection to the structural and insulation elements of a floor, wall and roof* construction.

* Note: For details of how Tyvek® membranes can help to achieve compliance in roof constructions, please refer to our Tyvek® Roofing Manual.

BBA Approvals

In order to demonstrate the suitability of Tyvek® breather membranes for use in wall construction, DuPont enlisted the services of the British Board of Agrément (BBA).

BBA assessments for materials such as Tyvek® are thorough and take into account the purpose for which the products have been designed and manufactured. As a breather membrane for use in timber frame wall systems BBA assessments will include tests for:

Strength	BS2782:1976 BS3137:1972
Water resistance	BS4016:1997 MOAT No.27/1983
Vapour permeability	BS3177:1959 BS EN ISO 12572

Other tests include: accelerated ageing, fire, quality control and practicability of installation.

After extensive testing of the individual Tyvek® grades the BBA have confirmed that Tyvek® Housewrap and Tyvek® Reflex are:

"...suitable breather membranes for use in timber frame constructions, either factory or site applied."

Performance information indicating results from the BBA assessments for all Tyvek® wall and floor products is contained in the Technical Data tables on pages 34 & 35.

Agrément Certificate No 90/2548 - for Walls

All Tyvek® wall membranes share the same BBA certificate. The various grades however have their own Detail Sheet:

Product Sheet 1	Tyvek® HOUSEWRAP	61g/m ² HDPE
Product Sheet 3	Tyvek® REFLEX	85g/m ² HDPE metallised and lacquered
Product Sheet 4	DuPont™ AirGuard® Control	
Product Sheet 5	DuPont™ AirGuard® Reflective	

HDPE = High Density Polyethylene

BRE Certificate No 155/10

Tyvek® UV Facade

Agrément Certificate No 08/4548 - for Roofs

All Tyvek® roof membranes share the same BBA certificate. The various grades however have their own Detail Sheet:

Product Sheet 1	Tyvek® SUPRO	for use in warm non-ventilated and cold ventilated roofs
Product Sheet 2	Tyvek® SUPRO	for use in energy efficient cold non-ventilated roofs
Product Sheet 3	DuPont™ AirGuard® Control	
Product Sheet 4	DuPont™ AirGuard® Reflective	



Tyvek® membranes wall applications

There are many different types of wall construction, most of which would benefit from the inclusion of a Tyvek® membrane. We have included some of the more common variations here as typical examples:

Fig. 3 Timber Frame
Traditional

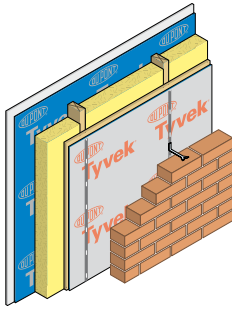

Fig. 4 Timber Frame
(Reverse construction)
Horizontal Weatherboarding

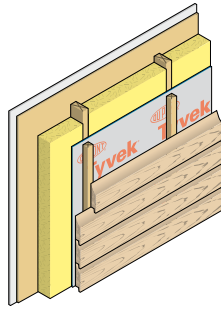

Fig. 5 Timber Frame
Vertical weatherboarding

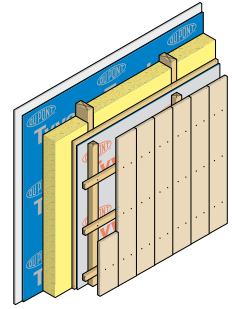

Fig. 6 Timber Frame
Vertical slate/tile hanging

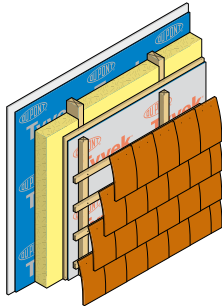

Fig. 7 Timber Frame
Cement render on lathe

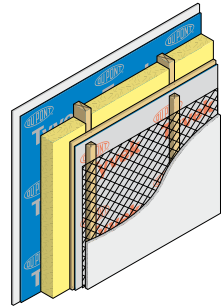

Fig. 8 Timber Frame
Façade cladding system

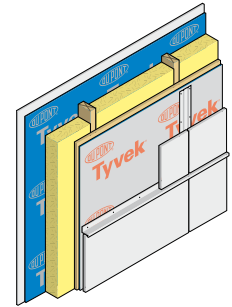

Fig. 9 Metal frame
Metal clad

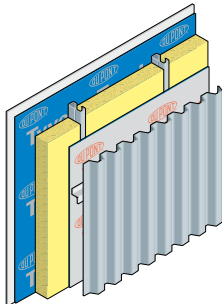

Fig. 10 Masonry wall
Internal insulation upgrade

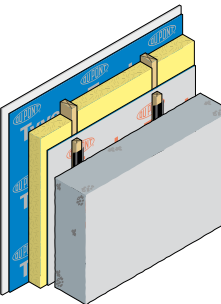
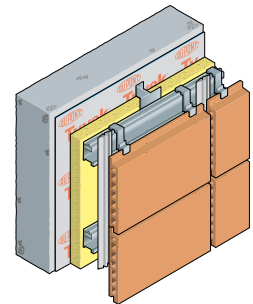

Fig. 11 Masonry wall
Rainscreen cladding



Vertical battens have been included in some details to ensure positive drainage of moisture. Although they may not always be required they are recommended particularly in areas subject to extremes of weather.

Tyvek® membranes installation in walls

The previous pages in this technical manual confirm the suitability of Tyvek® membranes in wall and floor applications. References to current legislative documents as well as approvals from the BBA further reinforce the message that the materials are 'fit for purpose' as breather membranes in wall constructions.

In order to attain maximum benefit from a Tyvek® membrane, both in terms of performance and warranty, it is important to ensure that correct installation procedures are followed.

The following pages contain information on how best to install Tyvek® membranes in wall constructions.

Although there are many construction variations the basic principles for installation remain the same. Many of the details included here are regarded as standard practise in the timber frame industry, thus we have drawn upon the knowledge and experience of TRADA Technology in these instances.

Detailing Timber frame walls

The external envelope of a timber frame wall system consists of two elements:

- The loadbearing timber frame wall
- The outer cladding. This may be a heavyweight cladding, supported independently by the foundations, or a lightweight cladding attached to the timber frame.

Fig. 12 - Typical timber frame wall brick cladding

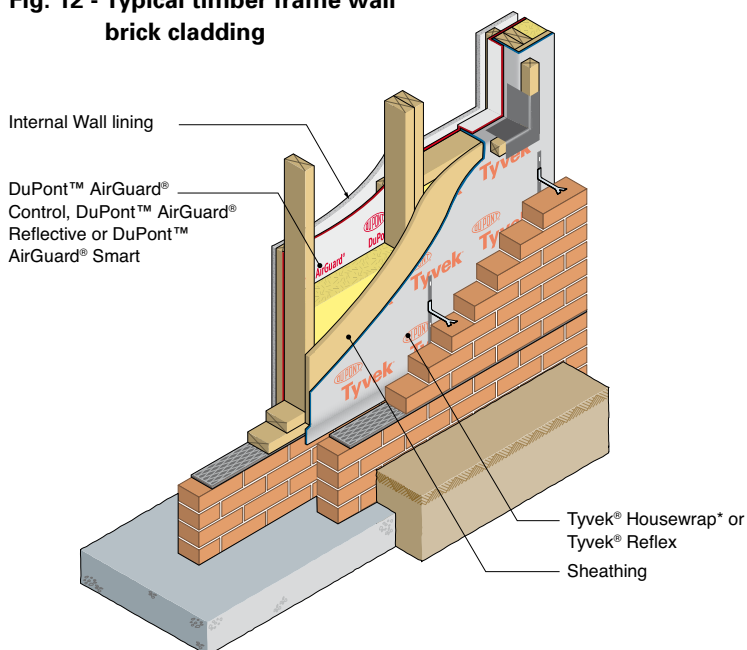

Typical timber frame construction employs timber studs and rails, together with a wood based sheathing, to form a structural frame which transmits all horizontal and vertical loads to the foundations. The exterior cladding is non-loadbearing, although it may contribute to wind resistance; it is used to weatherproof the building and to provide the desired external appearance.

Although vapour permeable and moisture resistant sheathing boards are sometimes used, the sheathing is generally plywood or oriented strand board (OSB). The breather membrane is fixed to the sheathing to form a complete secondary protection layer.

***All Tyvek® wall membranes are suitable in this application.**

Detailing Timber frame walls

A Tyvek® breather membrane can be installed either on site or as part of a factory fabrication process. In the UK, timber frame construction generally uses factory manufactured panels, with site application being carried out either by specialist companies or on relatively small scale projects. In this latter method, installation of the Tyvek® breather membrane would be carried out as soon as the shell of the building is erected.

Site installation

Fig. 13 - Overlap at sole plate/bottom rail

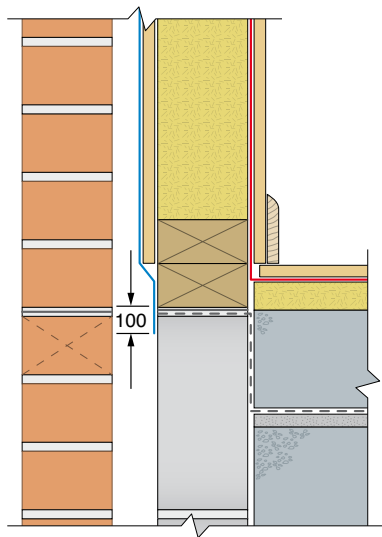
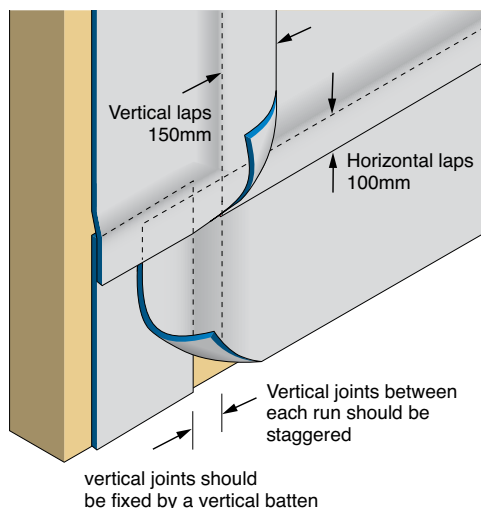

Fig. 14 - Horizontal and vertical laps



Application of the Tyvek® breather membrane on site starts from the sole plate or bottom rail upwards.

Sole plate (Fig. 13)

The Tyvek® membrane should be fixed at least 100mm below the lowest timber member, usually the sole plate.

The standard method of application for a Tyvek® breather membrane is for it to be unrolled horizontally over the face of the sheathing/framing, but it may also be laid vertically if this is more appropriate.

Laps (Fig. 14)

The upper run of Tyvek® membrane must overlap the lower to prevent water which may run down the wall from running behind the membrane. All horizontal laps should be at least 100mm and vertical laps 150mm.

Fixings

Tyvek® membranes are normally fixed to the sheathing with stainless steel staples or corrosion resistant nails. Fixings should be as follows:

Horizontal fixing

generally 600mm or at stud positions,

Vertical fixing

at stud positions	300 mm
at sides of openings	150 mm
at vertical membrane joints	150 mm
at end of panels*	150 mm

* required when membrane is fixed to panels in the factory.

Suitable membranes:

Tyvek® Housewrap, Tyvek® Soft, Tyvek® UV Facade and Tyvek® Reflex

Detailing Timber frame walls

The locations of the studs should be marked onto the Tyvek® breather membrane to determine wall tie or batten fixing points. This is commonly done by using an indelible marker pen. PVC banding tape may also be used and is particularly recommended where the site is located in an area of very severe exposure, as it strengthens the fixing.

Fig. 15 - Factory manufactured panel

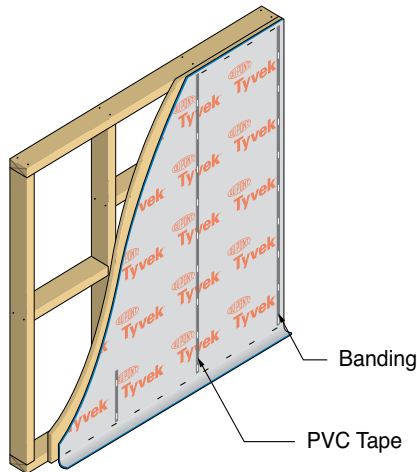

Pre-fabricated panels (Fig. 15)

Reinforcing tape is generally used where Tyvek® membranes are applied to panels in the factory. This provides additional tear resistance when transporting pre-made panels to site. Tyvek® membranes applied to panels in the factory should be fixed as listed in Table 1 and at the sides, head and base of each panel. The membrane should extend beyond the sides and base of panels to comply with the lap requirements shown in fig. 14.

Fig. 16 - Cavity barrier at intermediate floor junction

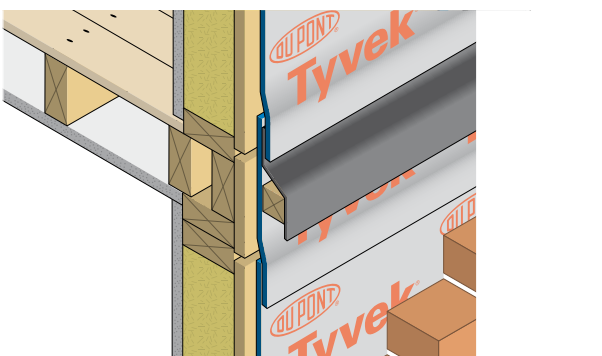

Floor junctions (Fig. 16)

The membrane at the base of upper storey panels should be extended sufficiently to cover the intermediate floor zone and provide a 100mm lap over the lower panel. Lap sections on pre-fabricated panels should be temporarily fixed back for transport.

Cavity barriers (Fig. 16)

The Tyvek® membrane should lap over DPCs at horizontal cavity barriers, fire stops and cavity trays. Cutting the membrane and sliding a DPC behind will be sufficient. Alternatively a separate skirting strip may be used to ensure an adequate lap detail.

Fig. 17 - External corner and window opening

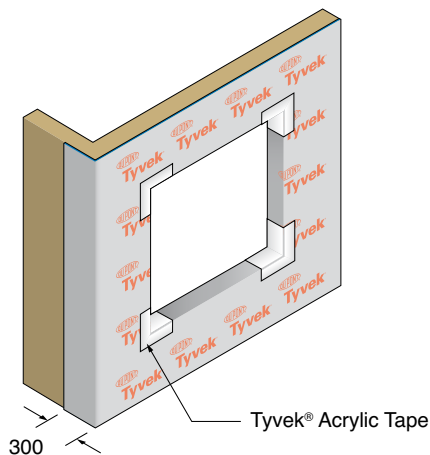

External corner (Fig. 17)

Returns around external corners should be at least 300mm.

Windows and doors (Fig. 17)

Extend the Tyvek® membrane over window and door openings. Cut an 'X' in the membrane and fold back. Make good to the corners with Tyvek® Acrylic Tape (single sided) or DuPont™ FlexWrap NF.

Fig. 18 - Window head (render & lathe)

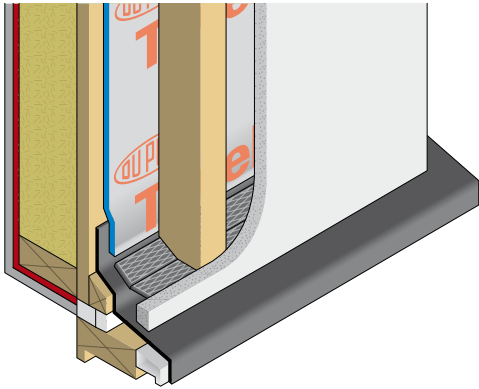

Window head

If an outer leaf of brick/block is being used dress the Tyvek® membrane over the cavity tray as in Fig. 16. If external cladding such as tile hanging, weatherboarding, render and lathe is used, dress the Tyvek® membrane over a proprietary flashing (Fig. 18).

Base details for cladding

Generally, the Tyvek® membrane is finished at base level as in Fig. 13. But the batten space behind the cladding, should be closed off with an insect mesh/screen (Fig. 19).

Fig. 19 - Base detail (render & lathe)

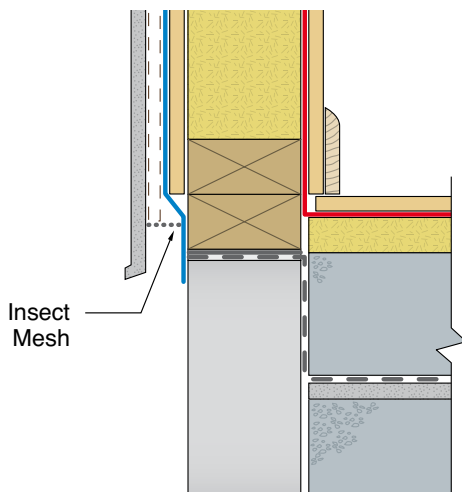

Fixing to masonry

An anchor fixing system involving a large plastic washer should be employed, such as a *Hilti X-SW soft washer fastener*.

Fixing to steelwork

Tyvek® may be fixed to steelwork with a self tapping screw, wall plug and washer, or an anchor system as for masonry, except with dedicated fixing such as *Hilti X-EDNI nail (and X-SW soft washer)*.

Damage repair

Any damage that occurs in a Tyvek® membrane should be made good as soon as possible:

Minor damage may be repaired with Tyvek® Acrylic Tape (single sided).

More extensive damage should be covered with a Tyvek® patch (Fig. 20)

Large areas of damaged Tyvek® should be replaced completely.

Fig. 20 - Damage repair

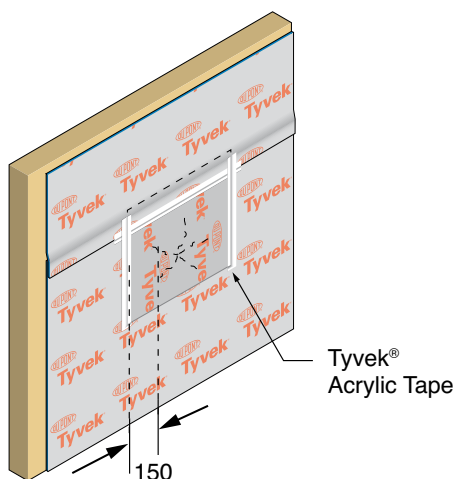

Airtightness

Heat loss by convection will occur at all horizontal and vertical laps, door and window details. Air leakage can be reduced by sealing the membrane at these points with adhesive tape. This can be achieved by using Tyvek® Acrylic Tape (single sided), Tyvek® Butyl Tape (double sided) and/or DuPont™ FlexWrap NF.

Suitable membranes:
 Tyvek® Housewrap, Tyvek® Soft,
 Tyvek® UV Facade and Tyvek® Reflex.

Detailing Timber frame walls

Vapour control - vapour diffusion

Timber frame wall construction involves the installation of a sheathing board fixed to provide wind bracing, lateral strength, etc. This layer is fixed to the external face of the framework, which is regarded as standard practice (see Fig. 12). Sheathing boards of plywood or oriented strand board (OSB) are commonly used, but contain adhesives and are relatively vapour resistant. Performance requirements regarding thermal and condensation control are generally met, but are in part dependant on the existence of other essential components such as an internal vapour control layer (VCL). Workmanship in installing a VCL is important as the integrity of this layer will determine its effectiveness in preventing/reducing water vapour transfer via convection into the construction. This is water vapour that can condense on any cold impermeable surface within the construction.

The “5 times rule”

Effective vapour diffusion, or *vapour release*, on the cold (external) side of the construction is equally as important as *vapour control* on the warm (internal) side. Materials on the warm side of the construction should have a greater vapour resistance than those on the cold side. As a guide, a ratio of at least 5:1 is recommended, also known as the “5 times rule” for vapour resistance. Installing a vapour resistant membrane internally to stop the vapour and a breathable membrane fixed externally to let vapour out will ensure that moisture is not trapped within the construction. This forms the basis of a “breathing wall” construction.

Reverse wall construction (Fig. 21)

An alternative process of constructing timber frame walls is to install the sheathing board on the internal side of the framework. The Tyvek® breather membrane can then be fixed

directly to the external face of the timber studs, providing protection to the construction as well as retaining the insulation. The benefit here is that when a sheathing board is installed internally it can provide additional vapour control for the system as the materials are generally vapour resistant. In this case particular attention will need to be paid at all board joints and penetrations to prevent excessive water vapour transfer into the construction. Sealing these weak points will assist in achieving a convection tight system. However, the use of a dedicated vapour control layer/air leakage barrier such as DuPont™ AirGuard® Control is still recommended between the sheathing board and insulation.

Fig. 21 - Reverse wall construction

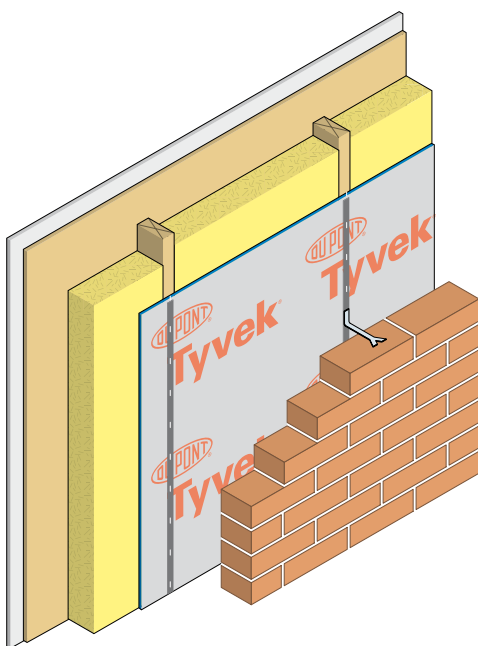

When timber frame walls are internally sheathed, the sheathing board may provide the racking strength, contribute to fire resistance, comply with surface spread of flame (reaction to fire) classification and provide the internal decorative surface. Such boards may include cement-bonded particleboard, fibre reinforced gypsum board, mineral fibre boards, and flame spread-treated plywood, OSB and chipboard.

The use of timber based boards as internal linings may be limited by surface spread of flame (reaction to fire) requirements. Their fire resistance can be improved with the application of treatments/coatings, but demonstration of compliance with the relevant fire regulations may still be required.

Suitable membranes:

Tyvek® Housewrap, Tyvek® Soft, Tyvek® UV Facade, and Tyvek® Reflex

Note: Specifying a reverse wall construction may affect details at junctions, floors, roof, etc. and designers should take this into account when considering this method of construction.

Detailing Masonry walls

Internal insulation upgrade (Fig. 22)

Existing solid masonry/stone walls invariably suffer from internal mould problems arising from condensation due to their poor thermal performance. Upgrading these constructions commonly involve the installation of an internal insulated panel. This has the benefit of providing a clean, dry internal lining as well as improving overall thermal performance. Condensation and mould growth will not then be apparent, but potentially can still occur on the masonry/stone surface, which is now hidden from sight within the construction. In normal circumstances the cavity between a timber frame wall and brick and block cladding should be 'self draining' and 'vented' to prevent the build-up of moisture. The installation of airbricks, cavity tray and weep holes would ensure this. However, as this may not be possible with an internal insulation upgrade, emphasis should be placed on the vapour controlling abilities of the internal lining to prevent vapour from diffusing into the construction in the first instance.

Fig. 22

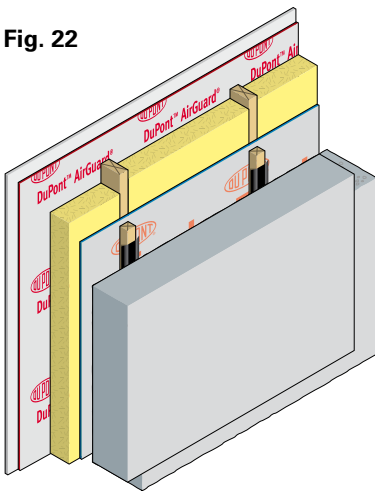

Battens should be fixed to the inside face of the existing wall via strips of DPC for protection against moisture. A new Tyvek® covered insulated panel can then be constructed away from the existing wall.

An internal air & vapour control layer (AVCL), such as DuPont Airguard Reflective should be installed with meticulous attention paid to all laps, edge details and penetrations. Sealing the AVCL in this system is key to the prevention of condensation on the inside face of the existing wall.

For best practice, the internal lining (plasterboard) should be spaced off the AVCL with battens, helping to minimise penetrations through the membrane. This newly formed 'services void' will also allow DuPont Airguard Reflective to boost the overall thermal value of the wall system.

Rainscreen cladding (Fig. 23)

Rainscreen cladding systems differ from other wall constructions, as although the membrane is still fixed directly to the structure, it is situated behind the insulation. This is due to the nature of the cladding system which employs a supporting rail that penetrates the insulation, making the application of an external membrane very problematic. Many rainscreen systems offer high levels of protection from precipitation and several insulation types are moisture resistant. In these instances a Tyvek® membrane may not be required, but joints should be considered.

Fig. 23

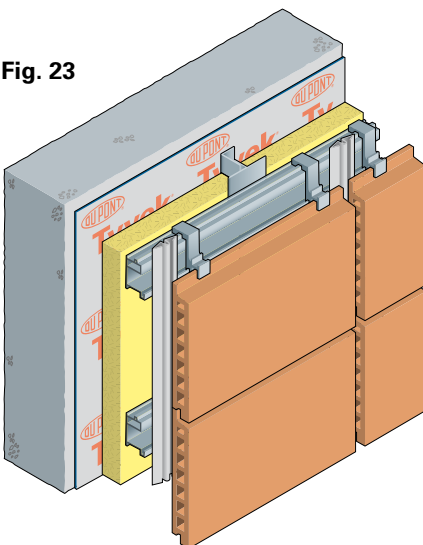

Where there is a risk of moisture penetration through the insulation and internal layers, a protection membrane behind the insulation is advised. The material to specify is dependant on the risk of condensation at this interface, determined in the main by the temperature. If in doubt a breather membrane should be used. In any case the material should be water resistant.

Fixing: For guidance on fixing Tyvek® to masonry and steelwork please refer to the notes on page 13

Suitable membranes:

Tyvek® Housewrap, Tyvek® Soft and Tyvek® UV Facade

Note: Tyvek® Reflex will not be suitable for use in Fig. 23.

Tyvek® UV Facade installation

Permanent protection for open and ventilated rainscreen cladding

Long-term performance

Facades with open rainscreen cladding offer new design options, but the insulation and structure still require effective, permanent protection from the harmful effects of the elements to which it is constantly exposed. In particular UV radiation can compromise the long-term performance of secondary protection membranes. That's why DuPont have developed Tyvek® UV Facade, an advanced protective membrane specifically designed to meet the needs of open cladding constructions.

Open Rainscreen Cladding (Fig. 23)

Tyvek® UV Facade ensures optimum protection of the insulation and structure in open or ventilated cladding constructions from sunlight, wind and moisture. Unique in its class, Tyvek® UV Facade is the only known protective membrane for open-jointed cladding systems to carry the CE marking, certifying full conformity with the European Union's rigorous construction products directive. To obtain the CE marking for open cladding use, the membrane has to resist an artificial aging by UV of 5000 hrs (for a standard wall/roof application it is 336 hrs), followed by a 90 days exposure to 70°C.

Fig. 24 Open rainscreen cladding

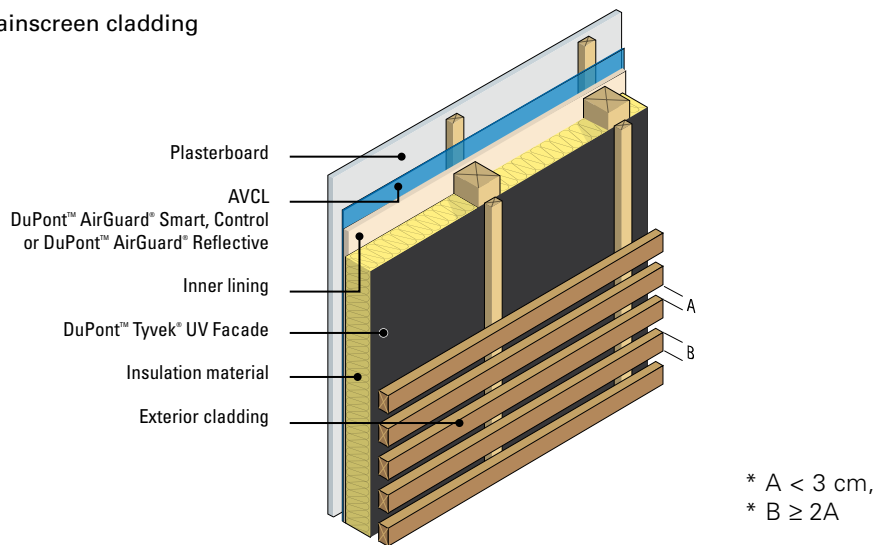

Unique Properties:

- Proven long-term UV resistance (only known membrane with publicly available CE marking for open cladding use)
- 10-years warranty for joint width of up to 3 cm
- Lifespan of over 50 years for joint width of up to 2 cm
- For open joints of up to 3 cm
- Wind-tight, water-tight but vapour-open
- Suitable for open or ventilated cladding in timber, metal, stone and other materials
- Extremely lightweight, flexible and easy to install
- Can be left uncovered for up to 4 months while retaining full performance

However we recommend to cover Tyvek® UV Facade just after its installation.

To seal overlaps we recommend the use of the two adhesive tapes below which are compatible with Tyvek® UV Facade:

- Tyvek® UV Facade Tape which has a high UV resistance, excellent ageing properties and long term outdoor performance.
- Tyvek® Double-sided Tape which has a strong initial tack and excellent adhesion properties under extreme humidity conditions and varying temperatures.



Tyvek® Reflex low emissivity breather membrane

Global Warming

Since the Rio Earth Summit addressed climate change as far back as 1992 the process of stabilising atmospheric carbon dioxide has been long and meticulous. The Kyoto Protocol which followed in 1997 set the targets and formed the international agreement for governments to make reductions in greenhouse gas emissions – reductions that count! The UK's Energy White Paper in 2003 and The Stern Review of 2006 have both added impetus to the cause, with the latter confirming the supporting scientific evidence as being "overwhelming."

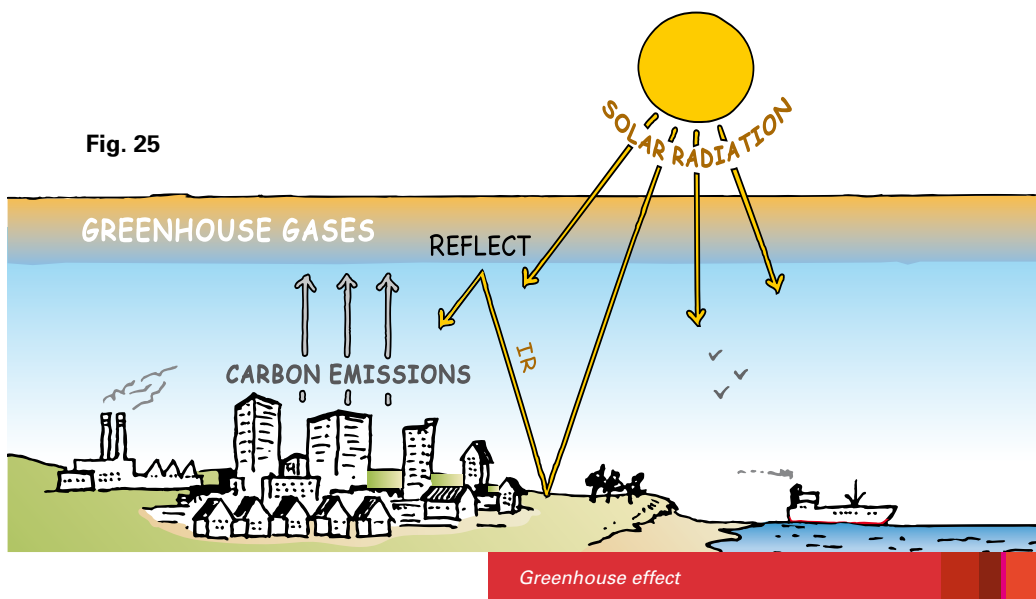

The prescribed solution for the UK is to achieve an 80% reduction in carbon dioxide emissions by 2050 compared to 1990 levels. Now enforced by the Climate Change Act 2008, with progress managed by the Department of Energy and Climate Change.

The environmental impact of UK Construction

The construction and use of buildings in the UK impacts upon the environment directly and reportedly contributes 46% of all CO₂ emissions, 27% from housing and 17% from non-domestic buildings. The strategy for the UK construction industry to achieve a sustainable environment and meet the new climate change objectives was set out within the EU Energy Performance of Building Directive (EPBD) in 2006. During its three year implementation period higher standards of energy conservation for new and refurbished buildings were initiated and the Energy Performance Certificate (EPC) was introduced.

The consultation document, Building a Greener Future: Towards Zero Carbon Development which followed the EPBD set the scene for today's legislation for all buildings to be constructed to higher sustainability performance standards. The document explained for the first time an ambition for all new homes to be net zero carbon by 2016 (compared to 2006 standards) and introduced The Code for Sustainable Homes as a guide to achieve this new commitment.

A step change in sustainable building practice

The transition to zero carbon emissions are being implemented in 3 steps:

1. **2010** : 25% improvement in energy/carbon performance
2. **2013** : 44% improvement
3. **2016** : zero carbon emissions for housing (2018 for non-domestic)

The Code for Sustainable Homes is closely linked to Building Regulations (Approved Document L) and takes into account 9 design categories, rating the whole home as a complete package. The Code uses a star rating system of 1 to 6 to communicate the overall sustainability performance of a new home according to a percentage improvement in CO₂ emissions:

- * = Code Level 1, 10% reduction
- ** = Code Level 2, 18% reduction
- *** = Code Level 3, 25% reduction
- **** = Code Level 4, 44% reduction
- ***** = Code Level 5, 100% reduction
- ***** = Code Level 6, zero carbon

Part L 2010 - 2013

The progressive changes to Approved Document L are intended to ensure that the prescribed reductions in carbon emissions are not just designed for but are actually achieved. CO₂ emissions from a newly constructed building are compared with a “notional” building of the same shape and size. The current method continues to use the 2002 model, but with a larger improvement factor over the one that was used for the performance targets of 2006. The 2010 update to Code Level 3 also included new energy efficiency standards for non-domestic buildings, with a requirement to achieve a 25% reduction, as for domestic buildings. Compliance for both types can continue to be demonstrated by the use of updated SAP or SBEM software. 2013 introduces further measures for a step up to Code Level 4 and a 44% improvement.

Part L continues to aim for high energy performance standards for the building fabric (walls, roofs, windows etc.) as well as its fixed building services (heating, lighting etc.). In addition to improvements in thermal insulation levels more control over thermal bridging and airtightness at junction details will need to be established. However, specific detailing can now be compared to a checklist within the Accredited Construction Details (ACDs) website, of the CLG’s Planning Portal.

Thermal efficiency

The improvements being made to the industry’s technical guidance are a logical progression over simply increasing the insulation, which has been the predominant solution to heat loss for the past 25 years. We are approaching what could be termed a reasonable limit in insulation thickness and we should now be looking for other ways to reduce heat loss through the building fabric. Consideration should therefore be given to the three modes of heat transfer collectively:

Conduction This is where heat is transmitted directly through a solid construction material. Installing a layer of thermal insulation within the building fabric will help to reduce conductive heat loss. The more insulation is used the greater the reduction, but this will result in an increase in the overall wall build-up, taking up internal space.

Convection Heat is lost as it is carried out of the construction by air movement occurring through cracks and joints in the building envelope. A continuous airtight layer normally installed on the internal side of the construction will significantly reduce convective heat loss. Information on DuPont™ AirGuard® Airtight Vapour Control Layers (AVCL’s) can be found on pages 22 to 27.

Radiation As heat energy is conducted to the colder external side of a construction layer, its mode of transfer changes from conduction to radiation. The heat energy is then emitted away from the surface of the construction, across an airspace in wave form - similar to radio and light waves. Heat loss by radiation can be reduced by installing a material that has an external surface of ‘low emissivity’ such as aluminium. This idea has been utilised already by some insulation manufacturers that face their products with foil. The benefits of reducing heat loss by radiation have also been realised by DuPont in the manufacture of a low emissivity membrane that is also vapour permeable:

Tyvek® Reflex low emissivity breather membrane

Tyvek® Reflex low emissivity breather membrane

Tyvek® Reflex is a low emissivity breather membrane suitable for use in any wall system that requires secondary protection from external moisture. It is the result of many years of research and development by DuPont to create a strong, water resistant and breathable membrane that assists in the reduction of heat transmission through the building envelope. It is particularly advantageous in lightweight wall construction such as timber or metal frame systems.

Composition

Tyvek® Reflex is manufactured by bonding aluminium particles to the external face of a 'soft structure' grade Tyvek® membrane. It is this metallised coating that presents the low emissivity surface, reducing the amount of heat being emitted from the construction. The overall thermal transmittance or U-value of the construction will be reduced because Tyvek® Reflex will reduce radiated heat losses.

Tyvek® Reflex can be categorised as a "Radiant Barrier".

A specially formulated lacquer has been applied to the external metallised face of Tyvek® Reflex to provide maximum protection against oxidation and abrasion. The lacquer presents minimum resistance to the passage of water vapour, with no risk of cracking. Tyvek® Reflex is therefore suitably durable and flexible for factory or site installation.

Tyvek® Reflex has Class W1 watertightness to EN 13859-2 and satisfies the requirements of BS4016 as a Type 1 breather membrane.

A reflective low emissivity membrane Tyvek® Enercor® Roof is available for use in pitched roofs which uses the same technology as Tyvek® Reflex and provides improved summer comfort levels.



Fig. 26

Test and accreditation history

TRADA

Initial assessment of Tyvek® Reflex determining water and tear resistance to BS 4016:1997 and water vapour transmission resistance to BS 7374:1990. **Confirmed suitable as a breather membrane in timber frame wall construction.**

BRE

Tests to ascertain thermal benefits offered by Tyvek® Reflex in timber frame wall construction. **A reduction of up to 15.6% in thermal transmittance achieved.**

BBA

Final tests to confirm Tyvek® Reflex as an insulating breather membrane. **Thermal benefit quantified by attributing thermal resistance of 0.54 m²K/W to adjacent cavity.**

Thermal value

Structural timber stud dimensions are critical factors especially in prefabricated units and increasing stud depths is not always practical. Despite this, stud sizes may need to be increased to accommodate more insulation in order to comply with the thermal regulations. Tyvek® Reflex can help to alleviate this due to the additional thermal resistance that it provides.

The thermal benefit provided by Tyvek® Reflex compared to a standard breather membrane is demonstrated on pages 26 & 27 (Referring to table of U-values including DuPont™ AirGuard® Reflective)

Condensation Risk

Increasing the thermal resistance of the adjacent airspace will also have the added benefit of reducing the risk of interstitial condensation. More heat will be retained within the ply/OSB sheathing as there is less heat being emitted by the membrane across the cavity. To reinforce this point the BBA have confirmed that Tyvek® Reflex '...will maintain the frame sheathing at a higher temperature than for the same construction incorporating a conventional breather membrane. This will in turn assist in limiting the risk of interstitial condensation ...'

Solar heat gain

Tyvek® Reflex will also help to reduce summer heat gain by reflection. Heat that builds up in the cavity behind brick/blockwork or an airspace behind cladding would normally be absorbed by the insulation/structure. The heat would then be transferred into the building by conduction and radiation. The metallised surface of Tyvek® Reflex will help to reduce this by reflecting the heat away from the structure beforehand. This would be particularly advantageous in constructions that contain minimal thermal insulation, eg. portable, lightweight or temporary buildings. A reduction in solar heat gain would also lessen the requirement for internal cooling provisions such as air-conditioning.

Tyvek® Reflex General Notes

Application

Tyvek® Reflex is installed into a wall system in a similar way to a standard breather membrane.

Orientation

Tyvek® Reflex is installed so that the "shiny silver" metallised side faces to the outside. The white reverse side of Tyvek® Reflex must not face into the cavity.

Damage Repair/Sealing

Tyvek® Metallised Tape is appropriate for sealing laps in Tyvek® Reflex to achieve airtightness and for damage repair.

Fig. 27

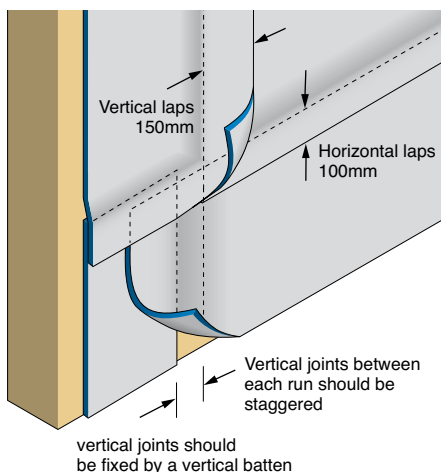

The upper run of Tyvek® Reflex must overlap the lower to prevent water from running behind the membrane. All horizontal laps should be at least 100mm and vertical laps 150mm (Fig. 27).

Pre-fabricated panels

(See also page 12)
Roll widths of 2.4m and 2.7m are particularly suitable for fixing Tyvek® Reflex to panels in the factory. When applying half-panel-width rolls such as 1.5m care should be taken to ensure horizontal joints are lapped correctly to provide adequate water shedding capability.

Fixings

Tyvek® Reflex should be fixed to the sheathing with stainless steel staples or corrosion resistant nails. Fixings should be as follows:

Horizontal fixing

generally 600mm or at stud positions,

Vertical fixing

at stud positions 300 mm
at sides of openings 150 mm
at vertical membrane joints 150 mm
at end of panels* 150 mm

* required when membrane is fixed to panels in the factory.

Internal Lining: DuPont™ AirGuard® Reflective, DuPont™

To compliment Tyvek® Reflex with a low emissivity internal membrane DuPont has developed DuPont™ AirGuard® Reflective - a completely airtight vapour control layer (VCL) that will also improve the wall's thermal performance. DuPont™ AirGuard® Reflective is designed to provide effective control against interstitial condensation both by diffusion and by convection. The membrane will reduce convective heat loss through the wall construction as well as retaining heat by reflecting it back in.

Installing DuPont™ AirGuard® Reflective behind a plasterboard internal lining will provide the following benefits:

- **Airtightness**
- **Vapour Control**
- **Thermal comfort**

Airtightness

Heat loss by convection isn't something that is highlighted by a standard U-value calculation, but is a significant cause of energy loss nonetheless. As we progress into the future with more energy efficient and sustainable building methods we are becoming more aware of the shortcomings of uncontrolled air leakage. This is now addressed within the latest requirements of Approved Document L, which sets out the parameters for the building envelope by limiting the design air permeability to $10\text{m}^3/(\text{h}\cdot\text{m}^2)$ at 50 Pa. Compliance is demonstrated by successful pressure testing in accordance with procedures given in Technical Standard 1 of the ATMA (Air Tightness and Measurement Association).

Uncontrolled air leakage occurs through gaps between and around insulation layers and through hairline cracks in plasterboard linings. These invariably occur during the building drying out process, but are also caused by settlement and thermal movement over the life of the building. Any layer in the building envelope where total continuity is not achieved is a potential weak point.

Vapour Control

DuPont™ AirGuard® Reflective offers high resistance to the passage of water vapour both by diffusion and convection. When installed continuously with all laps and penetrations sealed, the membrane will provide effective condensation control for all building types. This includes those of high humidity class, eg. swimming pools, textile factories, etc.

Thermal comfort

The metallised face of DuPont™ AirGuard® Reflective presents a low emissivity surface on the internal side of the wall construction. When used with a small airspace the membrane will reflect internally generated heat back into the building providing a back-up to traditional insulation. This reduction in heat transmission allows the airspace thermal resistance to be increased to $0.67\text{ m}^2\text{K/W}$. This will improve to the overall U-value of the wall system thus helping to reduce heating costs.

Pages 26 & 27 show likely U-values to be expected when using DuPont™ AirGuard® Reflective as the VCL in timber frame wall systems with standard stud sizes. Figures for standard breather membrane vs Tyvek® Reflex also included.

Fig. 28 – DuPont™ AirGuard® Reflective installation

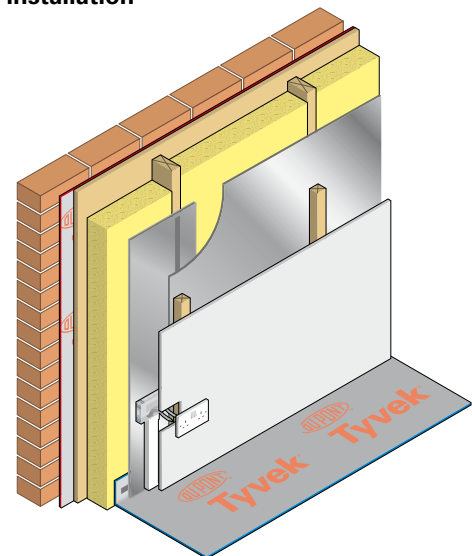

DuPont™ AirGuard® Reflective General Notes

Orientation

The orientation of DuPont™ AirGuard® Reflective is unimportant, but to utilise the membrane's thermal capacity its reflective surface must always face into an airspace. The preferred method is to install it with the reflective side facing into the building and then to fix a standard 25 mm batten over the membrane as described in the installation notes under batten space.

Continuity and sealing

As a vapour resistant and airtight membrane it is important to ensure DuPont™ AirGuard® Reflective is installed continuously with no breaks or open joints where air leakage can occur. All laps, penetrations and cuts in the membrane should be sealed with Tyvek® Metallised Tape as well as connections to adjacent airtight layers at roof and floor junctions.

DuPont™ AirGuard® Control General Notes

Installing DuPont™ AirGuard® Control as part of the internal lining will minimise uncontrolled convected heat losses through the building fabric. The objective is to provide a continuous barrier to air movement around the habitable space that is in contact with the inside of the thermal insulation layer. This includes separating walls and the edges of intermediate floors.

Fig. 32 – DuPont™ AirGuard® Control installation

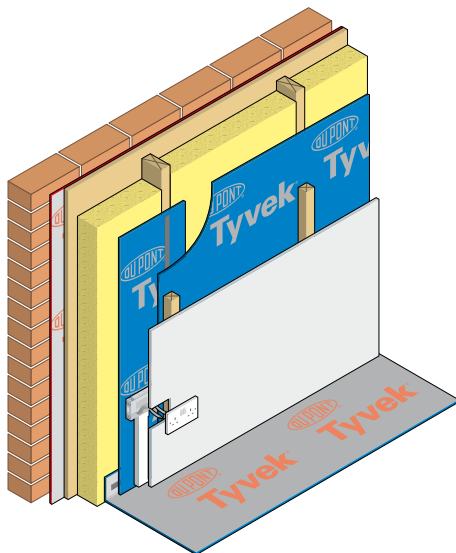

DuPont™ AirGuard® Control has been specifically developed for use as an air leakage barrier (ALB), but will also contribute in controlling the passage of vapour through a structure. Its use is particularly applicable in 'vapour open' wall constructions where external layers are of low vapour resistance.

Installing DuPont™ AirGuard® Control as the VCL will ensure that the overall 'breathability' of the construction is maintained with the correct balance of vapour resistances between internal and external layers. (See page 14 - The '5 times rule')

Composition

DuPont™ AirGuard® Control is composed of a layer of spunbonded polypropylene with a polyolefin coating.

Strength

DuPont™ AirGuard® Control is rot proof and has a nail tear resistance of 240N. It is an extremely durable material.

Note: When installing DuPont™ AirGuard® Control the installation procedures for DuPont™ AirGuard® Reflective should be followed. Total continuity of DuPont™ AirGuard® Control is paramount to achieve successful pressure testing at 50 Pa.

Internal Lining: DuPont™ AirGuard® Control, DuPont™ A

NEW DuPont™ AirGuard® Smart

DuPont™ AirGuard® Smart is a strong and lightweight flexible membrane for use as an internally applied airtight vapour control layer (AVCL).

Outstanding properties:

- Extreme vapour resistance range from 0.26 MNs/g to more than 150 MNs/g, (s_d value 0.05 m - more than 30 m), therefore highly adaptable → one of the widest vapour resistance spans known in the market
- Combines drying-out and vapour control function in one layer
- High drying-out potential = maximum protection against structural damage
- High tensile strength offering superior insulation support/retention
- Very robust - offering versatility in site work
- Airtight
- Transparent allowing the timber members to be easily located for fixing
- Easy to install - suitable for use in roof or wall constructions

How DuPont™ AirGuard® Smart works

The graph shows 2 extreme examples:

1. Wet (100%) and 2. dry (0%) building envelope structure and corresponding vapour R_s (resistance) - depending on ambient air relative humidity. The actual vapour R_s is a combination of both the moisture content of the building envelope and relative humidity of the internal air. DuPont™ AirGuard® Smart provides traditional vapour control to the diffusion of vapour from the building interior, whilst offering a high drying-out potential of built-in moisture back into the building.

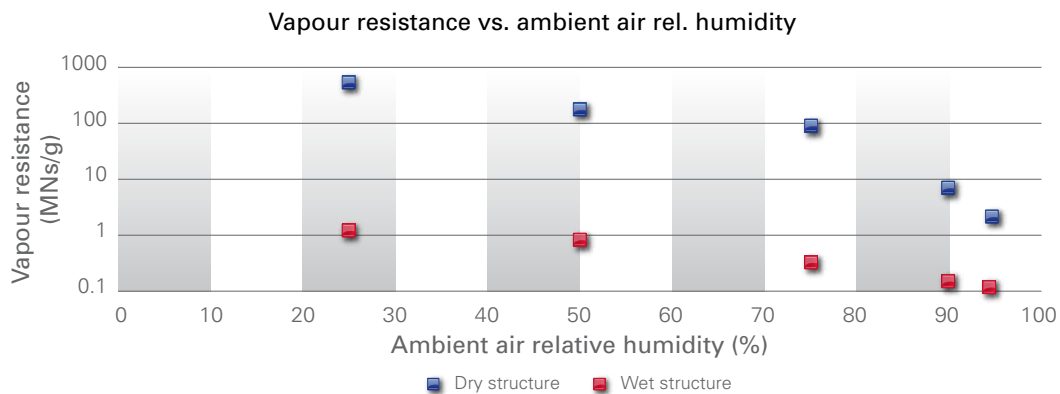

What happens just after a new build construction or after renovation?

New construction

Condition just after completion: Moisture is confined within the building envelope; damp timbers, insulation, etc, due mainly to wet building processes.

A new-build property will very often have a high relative humidity due to the rapid drying of the building fabric. Hence after completion, the owner has to adequately ventilate the building interior to expel the moisture rather than allow it to migrate through the construction where it can condense and cause harm. If needed the DuPont™ AirGuard® Smart allows moisture within the building fabric to migrate back into the building. Where the moisture content within the structure is high the vapour resistance of DuPont™ AirGuard® Smart will always be low. This will allow the structural elements and the insulation to dry out towards the warm side of the building, in addition to the normal process of vapour diffusion through the external DuPont™ Tyvek® breather membrane.

Renovation

Condition just after completion: Building structure and insulation dry after brief humidity stabilisation.

In the case of a dry building structure, DuPont™ AirGuard® Smart acts as a traditional AVCL, providing effective condensation control and airtightness. Even in temporarily high air humidity zones water vapour diffusion is reduced*. The vapour resistance of DuPont™ AirGuard® Smart will be between 0.26 MNs/g and more than 150 MNs/g, (S_d value 0.5 m - more than 30 m). The migration of newly generated moisture through the construction will be significantly reduced.

Installation: DuPont™ AirGuard® AVCLs

1 - Service Void

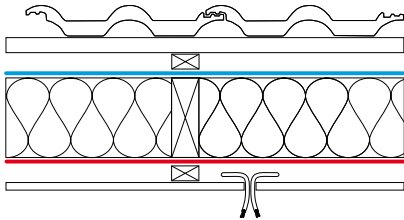

2 - Wall to ceiling junction

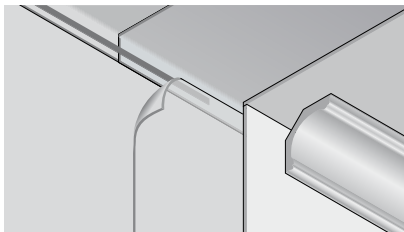

3 - Penetrations

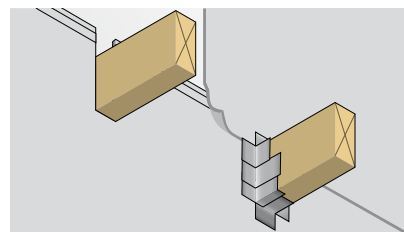

4 - Window/door frame sealing

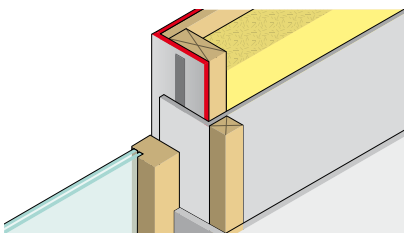

Detailing

The integrity of a DuPont™ AirGuard® AVCL is essential for it to perform as an effective vapour control layer and air leakage barrier. The internal lining (plasterboard, etc.) may be fixed directly through the membrane if required. However, for maximum efficiency and best practice the internal lining can be fixed via battens to minimise penetrations through the membrane. Installing battens will also create a services void for wiring and pipework (Detail 1). (See also Fig.28 & Fig.32)

Continuity of the membrane should be maintained at adjacent walls, floors and roofs with Tyvek® Butyl Tape (Detail 2)

Wall - upper storey floor joists

Note: To ensure continuity, the DuPont™ AirGuard® AVCL must be installed before installation of plasterboard to the ceiling and boarding to the upper floors.

Extend the DuPont™ AirGuard® AVCL above ceiling/ floor joists by a minimum of 100mm. Cut and dress the membrane around all joists and make good/seal with Tyvek® 2060B Tape. Bond the membrane to upper storey sheets using Tyvek® Butyl Tape (Detail 3).

Penetrations

Penetrations through the DuPont™ AirGuard® AVCL should be kept to a minimum and any that are made should be sealed. Penetrations for pipework, wiring and electrical sockets should be sealed with Tyvek® 2060B Tape, Tyvek® Metallised Tape or DuPont™ FlexWrap NF (Detail 3).

Windows/doors

The DuPont™ AirGuard® AVCL should be made vapour and convection tight at all window and door openings. The membrane should be dressed neatly into the reveal and sealed to the frame with Tyvek® 2060B Tape or Tyvek® Butyl Tape. The membrane may be compressed by the frame if the window/door unit is to be fitted retrospectively (Detail 4).

Damage

If a DuPont™ AirGuard® AVCL is abraded or punctured in any way the damaged area should be made good with Tyvek® 2060B Tape or Tyvek® Metallised Tape. Extensive damage should be covered with a patch made from the same material and sealed with Tyvek® 2060B Tape or Tyvek® Metallised Tape. The membrane should be made vapour and convection tight at all window and door openings and sealed with Tyvek® Butyl Tape or tucked in and compressed by the frame.

Timber Frame Wall Solutions for Part L and Scottish

Timber stud dimensions are critical factors in timber frame design and manufacturing. However, in order to satisfy the ever-changing energy requirements, stud sizes may need to be increased to accommodate more insulation. These tables show how the U-values in timber frame wall constructions can be improved by incorporating Tyvek® Reflex and DuPont™ AirGuard® Reflective in combination with an airgap.

1- U-Values of entire wall construction achieved with 89 mm stud (and 89 mm fibrous insulation)

Insulation	λ (W/m K)	U-value (W/m ² K)		
		Standard Membrane	Tyvek® Reflex	Tyvek® Reflex + DuPont™ AirGuard® Reflective
Mineral Roll	0.044	0.45	0.39	0.32
Mineral Batt	0.038	0.41	0.37	0.29
	0.037	0.42	0.35	0.30
	0.035	0.40	0.34	0.29
	0.032	0.39	0.32	0.28
PIR	0.023*	0.34	0.30	n/a

* PIR insulation 70 mm thick and foil faced to leave 20 mm service void

2- U-Values of entire wall construction achieved with 95 mm stud (and 95 mm fibrous insulation)

Insulation	λ (W/m K)	U-value (W/m ² K)		
		Standard Membrane	Tyvek® Reflex	Tyvek® Reflex + DuPont™ AirGuard® Reflective
Mineral Roll	0.044	0.43	0.38	0.31
Mineral Batt	0.038	0.40	0.35	0.29
	0.037	0.40	0.34	0.29
	0.035	0.39	0.33	0.28
	0.032	0.37	0.32	0.27
PIR	0.023*	0.32	0.29	n/a

* PIR insulation 75 mm thick and foil faced to leave 20 mm service void

■ Best
 ■ Good
 ■ Normal
 ■ Poor

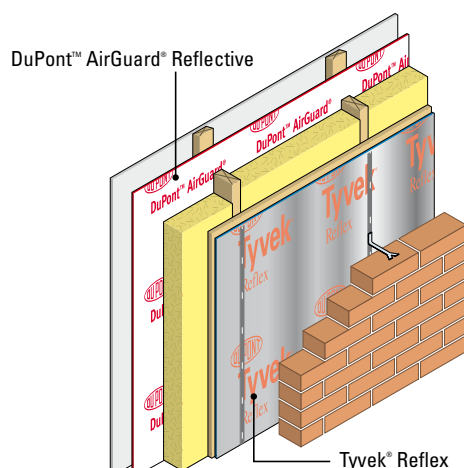

Fig. 33 – DuPont™ AirGuard® Reflective and Tyvek® Reflex installation

Technical Standard 6

3- U-Values of entire wall construction achieved with 120 mm stud (and 120 mm fibrous insulation)

Insulation	λ (W/m K)	U-value (W/m ² K)		
		Standard Membrane	Tyvek® Reflex	Tyvek® Reflex + DuPont™ AirGuard® Reflective
Mineral Roll	0.044	0.36	0.32	0.27
Mineral Batt	0.038	0.34	0.30	0.25
	0.037	0.33	0.30	0.25
	0.035	0.32	0.29	0.25
	0.032	0.31	0.28	0.24
PIR	0.023*	0.27	0.24	n/a

* PIR insulation 100mm thick and foil faced to leave 20mm service void.

4- U-Values of entire wall construction achieved with 140 mm stud (and 140 mm fibrous insulation)

Insulation	λ (W/m K)	U-value (W/m ² K)		
		Standard Membrane	Tyvek® Reflex	Tyvek® Reflex + DuPont™ AirGuard® Reflective
Mineral Roll	0.044	0.32	0.29	0.25
Mineral Batt	0.038	0.30	0.27	0.23
	0.037	0.29	0.27	0.23
	0.035	0.29	0.26	0.22
	0.032	0.27	0.25	0.22
PIR	0.023*	0.24	0.21	n/a

** PIR insulation 120mm thick and foil faced to leave 20mm service void.

Best
 Good
 Normal
 Poor

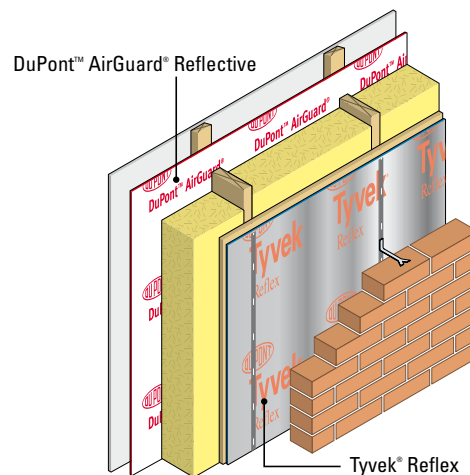

Fig. 34 – DuPont™ AirGuard® Reflective and Tyvek® Reflex installation

Tyvek® membranes Installation in suspended timber

Moisture Management

When a structural timber floor system is installed, the joists should be strength graded and have an average wood moisture content of not more than 20%. Any higher and the risk of mould formation is increased leading to eventual decay and structural failure. In order to retain the integrity of timber floor components, current guidance recommends that cross ventilation is provided to the airspace beneath. This is common practise and is recommended to ensure that any water vapour in the air beneath the floor will not condense and damage the structure. Moisture that is present in adjacent concrete, brick and block components will also be allowed to dry out sufficiently.

Air-leakage

Ventilating beneath a suspended timber floor system is an effective means of removing moisture laden air, but can be thermally detrimental. Insulated timber floor systems commonly include discontinuous insulation between the joists. The gaps and joints at the edges of the insulation will allow cold external air to filtrate into the construction, accelerating the rate of heat loss and so reducing thermal performance. Cold air infiltration may also create cold surfaces within the construction, potentially increasing the risk of condensation. It is therefore important to achieve airtightness in suspended timber floor systems.

Airtightness

Tyvek® membranes are generally regarded as airtight materials as they will resist the passage of convective air currents. Installing a Tyvek® membrane beneath floor insulation will therefore assist in improving the overall airtightness of the floor construction. Similar to the installation of DuPont™ AirGuard® Control, Smart or DuPont™ AirGuard® Reflective (see internal lining), workmanship in installing a Tyvek® membrane for airtightness is paramount. The extent of penetrations made by fixing the membrane should be controlled to a reasonable minimum. Sealing the membrane around fixing points may not be necessary if flat headed nails are used, but laps and edge details should be sealed.

Note: Airtightness can only be achieved if the membrane is laid continuously with sealed laps.

It is common knowledge that heat displaces air upwards. As moisture is contained within the air, it is reasonable to suggest that a large amount of water vapour within a building will escape at high level by convection.

However, water vapour should still be allowed to diffuse freely through the floor into the ventilated space. The vapour permeable characteristics of a Tyvek® membrane will ensure the floor construction is airtight and vapour open.

Fig. 35

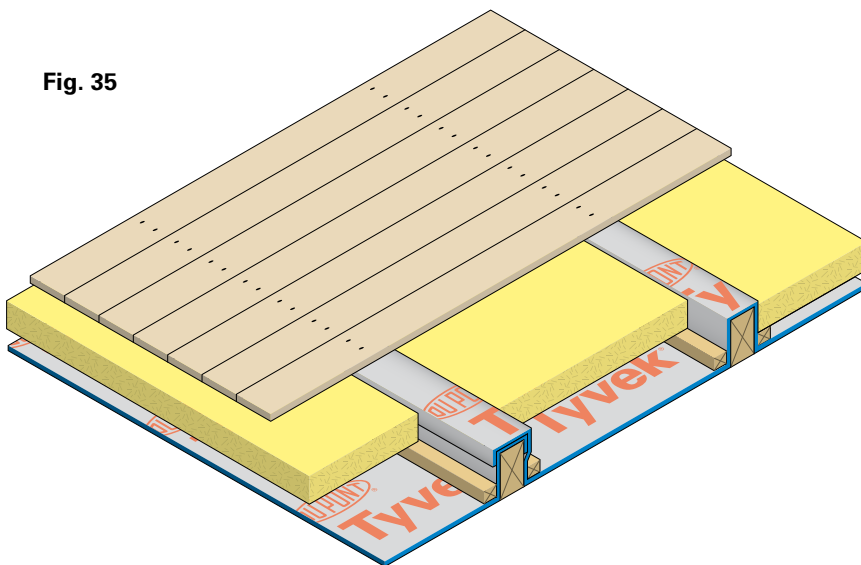

Material selection

Tyvek® Supro is a reinforced grade material which will provide adequate support to the insulation and is recommended for use in timber suspended floor systems. Please refer to pages 2 & 34 for product information.

Suspended timber floors

Fig. 36 - Wall junction - joists running parallel

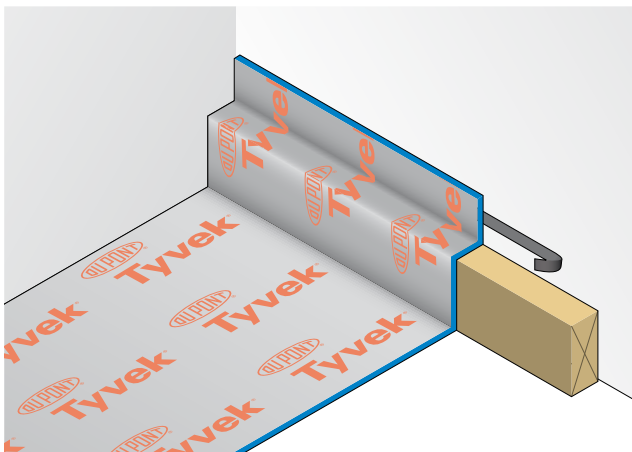

Fig. 36a - Wall junction - joists at right angles

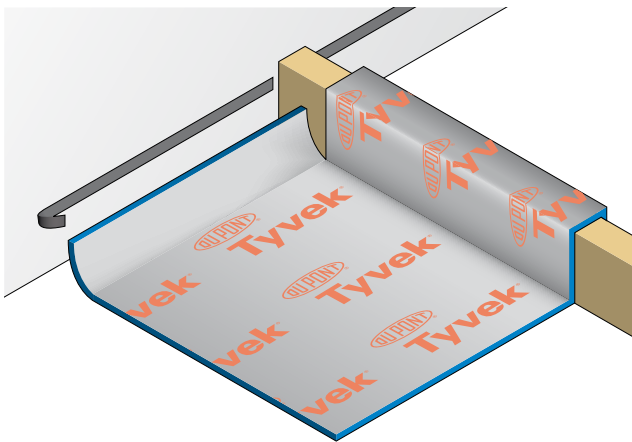
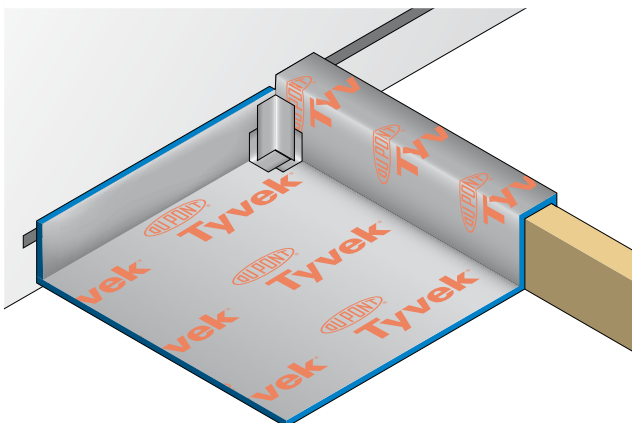

Fig. 36b



Installation

Ideally Tyvek® Supro would be fixed continuously to the underside of the joists, although in most cases this would not be possible as the space beneath the floor would not permit access. The most workable procedure is to wrap the membrane over the joists as in Fig. 35.

Fixing

Tyvek® Supro can be fixed into the tops of the joists using stainless steel staples or galvanised clout nails at approx. 500 mm centres. Fix Tyvek® Supro to the sides of the joists with battens at low level.

Laps and sealing

Laps between each sheet of Tyvek® Supro should be 100mm min. Seal the laps with Tyvek® Butyl Tape or compress beneath floor boards.

Wall junction - joists parallel

Continue Tyvek® Supro up and over the perimeter joist and lap 100mm against the wall, behind the VCL (if present). Seal Tyvek® Supro to the wall using Tyvek® Butyl Tape (Fig. 36).

Wall junction - joists at right angles

Sealing Tyvek® Supro will be difficult where the joists run into the wall. In order to achieve airtightness, the membrane should be cut, shaped and sealed against the wall and joist. Cuts and edge joints should be made good with Tyvek® 2060B Tape (Figs. 36a/36b).

Additional notes on sealing

Tyvek® Supro should also be sealed against a VCL in the wall using Tyvek® Butyl Tape, Tyvek® Double-sided Tape and/or Tyvek® 2060B Tape.

Service penetrations through the Tyvek® membrane should be sealed using Tyvek® Butyl and/or Tyvek® 2060B Tape.

Internal layers

A further reduction in air leakage can be achieved by installing DuPont™ AirGuard® Control, Smart or DuPont™ AirGuard® Reflective with taped laps directly beneath the internal floor finishes. The membrane can be installed either above or beneath the floor boarding to form a continuous internal vapour control layer and air leakage barrier.

Tyvek® membranes wall and floor applications

SPECIFICATION

Breather Membrane

Shall be Tyvek® Housewrap, Tyvek® Soft, Tyvek® Supro, Tyvek® Reflex or Tyvek® UV Facade as manufactured and sold by DuPont de Nemours (Luxembourg) S.à r.l. and serviced by

DuPont™ Tyvek®
Hither Green Estate,
Clevedon, North Somerset.
BS21 6XU.
Tel: 01275 337660
Fax: 01275 879033

Storage

Rolls should be stored palletised or on their sides on a smooth clean surface, under cover and protected from direct sunlight.

General

Care should be taken when handling the membrane in order to prevent tears and punctures occurring. Any that do occur should be repaired with Tyvek® 2060B tape. Tyvek® Metallised Tape is recommended for use with Tyvek® Reflex and Tyvek® UV Facade Tape for Tyvek® UV Facade breather membrane.

Application

Unroll Tyvek® breather membrane horizontally over the face of the construction, ensuring maximum coverage and protection to all wall/framing components behind. Extend membrane beyond timber sole plates by a minimum of 100mm.

Orientation

The Tyvek® breather membrane is installed with the following side facing outwards into the cavity/batten space:

- Tyvek® Housewrap - Grey printed side & DuPont logo
- Tyvek® Soft - DuPont logo
- Tyvek® Supro - Grey printed side & DuPont logo
- Tyvek® Reflex - Silver reflective surface
- Tyvek® UV Facade - Black surface

Temporary fixing

Tyvek® Butyl Tape may be used for short-term temporary fixing prior to the installation of external insulation, battens or cladding brackets. Care should be taken to limit the exposure period in such instances.

Fixing - to timber studs/sheathing

Fix Tyvek® breather membrane with stainless steel staples or corrosion resistant nails. Fix at max 600mm centres horizontally and 300mm centres vertically. At joints and openings fix membrane at max 150mm centres.

Fixing to insulation

Fix Tyvek® breather membrane to rigid insulation with a proprietary expanding insulation fixing anchor. In cladding applications timber battens or metal brackets may also be used to fix the membrane.

Fixing to steelwork

Fix Tyvek® breather membrane to steelwork with an appropriate fixing system such as a 25mm Steel Framing Screw with an EPDM rubber washer

Fixing - to masonry

Fix Tyvek® breather membrane to masonry with an anchor fixing system or masonry nail and EPDM rubber washer.

Fixing to cement bonded particle board (CBPB)

In most cases a Tyvek membrane can be temporarily fixed to a CBPB with a good quality and sufficiently heavy duty stainless steel staple. These should be fixed at 500mm centres vertically and 1m centres horizontally. For air leakage purposes the staple penetration may need to be sealed with a patch of Tyvek® 2060B tape.

- Alternative fixing of the membrane can be achieved with a drill tip screw through the CBPB and into the metal framing. The head of the screw must have a low profile flat head to sit flush against the membrane. An EPDM rubber washer should sit between the screw head and the membrane for air sealing purposes. Screw fixings should be spaced at a minimum 1m centres vertically at every stud position.

Rainscreen cladding applications - general note

A Tyvek® breather membrane is normally fixed to the structural wall element (masonry or cementitious board) prior to the fixing of the helping hand bracket system and insulation. Tyvek® Housewrap, Tyvek® Soft and Tyvek® Supro are suitable.

Free spanning condition

Tyvek® Supro must be specified if the membrane is to span freely between vertical or horizontal members with no supporting sheathing behind. Maximum span should not exceed 1.2m in a protected environment, or 600mm if exposed to wind loading.

Laps

Horizontal laps should be 100mm min. Vertical laps should be 150mm min.

External corners

Dress Tyvek® breather membrane around external corners ensuring a return of 300mm min.

Window openings

Wrap Tyvek® breather membrane into window/door openings and make good to corners with Tyvek® 2060B tape or Tyvek® Metallised Tape. For improved weather sealing around details use Tyvek® Flexwrap NF.

Cavity barriers/trays/flashings

Dress Tyvek® breather membrane over cavity barrier/tray/flashings ensuring a minimum lap of 100mm.

Floor junctions

Dress Tyvek® breather membrane over intermediate floor zone ensuring a minimum lap of 100mm between sheets

Airtightness - sealing (optional)

All Tyvek® membranes have been tested for 'Resistance to penetration of air' in accordance with EN 12114. With all laps and penetrations sealed, a Tyvek® breather membrane will contribute to the overall airtightness of the building. Seal the laps in Tyvek® breather membrane with the following tape:

- Tyvek® Housewrap - Tyvek® 2060B Tape
- Tyvek® Soft - Tyvek® 2060B Tape
- Tyvek® Supro - Tyvek® 2060B Tape
- Tyvek® Reflex - Tyvek® Metallised Tape
- Tyvek® UV Façade - Tyvek® Acrylic Tape (double-sided)

SPECIFICATION

Fixing penetrations can be sealed by applying Tyvek Butyl Tape to the substrate before the membrane is installed.

Compatibility

Where timber treatments are used care should be taken to ensure they are touch-dry before the installation of the Tyvek® membrane. Retrospective spray applied micro emulsions can also pose significant risk to polymer based materials such as Tyvek®. Masking the membrane against such preservative treatments should be considered.

Air & vapour control layer (AVCL)

Shall be DuPont™ AirGuard® Control, Smart or DuPont™ AirGuard® Reflective as manufactured and sold by DuPont de Nemours (Luxembourg) S.à r.l. and serviced by

DuPont™ Tyvek®
Hither Green Estate,
Clevedon, North Somerset.
BS21 6XU.
Tel: 01275 337660
Fax: 01275 879033

General

A DuPont™ AirGuard® AVCL is installed onto the internal side of the building envelope with the printed logo facing into the building interior. The membrane may be laid either horizontally or vertically to suit the substrate.

Temporary fixing - to timber

Fix the DuPont™ AirGuard® AVCL using stainless steel staples at appropriate centres or Tyvek® Butyl Tape. The membrane should be permanently fixed with a timber batten or the internal lining.

Temporary fixing - to steelwork/masonry/foil faced insulation

The DuPont™ AirGuard® AVCL may be temporarily fixed using Tyvek® Butyl Tape. The membrane should be permanently fixed with timber battens or the internal lining.

Laps sealing & tape selection

Maintain 100mm laps between each sheet and seal the laps with the following single sided tape:

- DuPont™ AirGuard® Control - Tyvek® 2060B Tape
- DuPont™ AirGuard® Smart - Tyvek® 2060B Tape
- DuPont™ AirGuard® Reflective - Tyvek® Metallised Tape

Detailing

Cover entirely the inside face of the wall, ensuring maximum coverage at all details. Maintain its continuity at adjacent walls, floors and roof junctions with a single-sided Tyvek® tape as listed above and/or Tyvek® Butyl Tape. Overlaps onto adjacent surface must be 100mm minimum.

Windows/doors/loft hatches

The DuPont™ AirGuard® AVCL should be made vapour and convection tight at all window and door openings and especially loft hatches. The membrane should be sealed tight against the frame with the appropriate single-sided Tyvek® tape as listed above, Tyvek® double sided Acrylic Tape or Tyvek® Butyl Tape or tucked in and compressed by the frame.

Penetrations

The DuPont™ AirGuard® AVCL should be cut and neatly formed around any penetrations made by floor joists, electrical switches, pipework, wiring and ducting and sealed with the appropriate single-sided Tyvek® tape as listed above. Fixing penetrations may be sealed with Tyvek® Butyl Tape.

Batten space/Service void

For best practice the internal lining (plasterboard, etc.) should be spaced off the DuPont™ AirGuard® AVCL to create a services void. This will help to avoid penetrations through the membrane by electrical sockets, light switches, etc. Timber battens of minimum 25mm may be used for this.

Note: A batten space is required if the thermal function of DuPont™ AirGuard® Reflective is to be utilised.

Damage

If the DuPont™ AirGuard® AVCL is abraded or punctured in any way the damaged area should be made good with an appropriate single-sided Tyvek® tape as listed above. Extensive damage should be covered with a patch made from the same material.

Electrical switches/sockets

Where no services void exists a sealed enclosure should be formed behind electrical switches and sockets. The enclosure must be sealed to the membrane using Tyvek Butyl Tape or a single-sided Tyvek® tape as listed above. Wiring penetrations through the DuPont™ AirGuard® AVCL must be sealed as much as possible.

Quality Management

The Tyvek® production units are certified ISO 9001: 2008. The Luxembourg site as a whole is certified according to the ISO 14001 Environmental Management System Standard and was the first manufacturing site in Luxembourg to be registered within the voluntary EMAS eco-management system.

Tyvek® membranes wall and floor applications

SPECIFICATION Timber Suspended Floors



Breather membrane/insulation support membrane

Shall be Tyvek® Supro as manufactured and sold by DuPont de Nemours (Luxembourg) S.à r.l. and serviced by

DuPont™ Tyvek®
Hither Green Estate,
Clevedon, North Somerset.
BS21 6XU.
Tel: 01275 337660
Fax: 01275 879033

Laying - continuously beneath floor joists (if access permits)

Unroll Tyvek® Supro at right angles to timber joists and secure with stainless steel staples or corrosion resistant nails. Fix at max. 300 mm centres along each joist.

Laps

Maintain min. 100 mm laps between each sheet and seal with Tyvek® Butyl Tape.

Laying – wrapped over floor joists

Unroll Tyvek® Supro so that it is laid at right angles to the timber joists. Form the membrane over the tops and down the sides of the joists.

Fixing - with battens

Fix Tyvek® Supro with stainless steel staples or corrosion resistant nails at min. 500 mm centres along the tops of each joist. Secure Tyvek® Supro to the sides of the joists at lower level using battens of 19 x 38 mm min.

Fixing - without battens

Fix Tyvek® Supro with stainless steel staples or corrosion resistant nails at max. 300 mm centres along the tops of each joist.

Laps

Maintain min. 100 mm laps between each sheet and seal with Tyvek® Butyl Tape or Tyvek® 2060B Tape.

Wall junction

Bond Tyvek® Supro to the wall AVCL with Tyvek® Butyl Tape, ensuring overlap of 100 mm min. If cutting around joists make good to cuts and joints using Tyvek® 2060B Tape.

Sealing – additional notes

Service penetrations through the Tyvek® membrane should be sealed using Tyvek® Butyl and/or Tyvek® 2060B Tape.

Questions & Answers

Re: Tyvek® Housewrap, Tyvek® Soft, Tyvek® UV Facade, Tyvek® Supro and Tyvek® Reflex.

Where does a Tyvek® breather membrane go?

In wall constructions, behind the external cladding/brickwork, etc.

What does a Tyvek® breather membrane do?

Tyvek® breather membranes provide protection to the structure and thermal insulation from external moisture and condensation. They also assist in achieving airtightness to reduce convective heat losses from the building if the joints are sealed.

Do the joints in Tyvek® breather membranes have to be sealed?

No, sealing is optional.

Should there be a vented cavity/airspace on the outside of the Tyvek® membrane?

Yes, to allow vapour to escape to outside atmosphere. The cavity/airspace may be vented naturally through cladding/tile joints or ventilated with airbricks, vents, etc.

Can a Tyvek® membrane be installed directly behind cladding or render & lathe?

Yes, but the breathability of the membrane will be less effective.

Please note, Tyvek® Reflex requires an air space to provide thermal benefits.

Can a Tyvek® membrane be installed behind continuous metal sheeting as the separation layer?

Yes.

No, if Tyvek® Reflex is being used.

Can a Tyvek® breather membrane be left exposed prior to the external cladding being installed?

Yes, for 4 months, provided that the membrane is secured sufficiently to prevent wind damage.

Re: Tyvek® Reflex.

Why use Tyvek® Reflex?

As well as providing protection against external moisture, condensation and air infiltration Tyvek® Reflex considerably reduces the amount of heat that is lost by radiation.

Which way around should it be installed?

Tyvek® Reflex is installed so that the shiny silver side faces a cavity.

Re: Tyvek® Supro

Can Tyvek® Supro be used as the breather membrane in a wall system?

Yes, Tyvek® Supro has all the attributes of a breathable membrane to BS4016 and EN13859. Its extra strength allows it to be surface applied or used in a 'free spanning' application (page 26).

What does Tyvek® Supro do in floor construction?

Tyvek® Supro will provide a support to insulation as well as providing protection against external moisture, condensation and air infiltration.

Re: DuPont™ AirGuard® Smart

What is DuPont™ AirGuard® Smart for?

DuPont™ AirGuard® Smart is a strong and lightweight flexible AVCL with variable vapour resistance, which means that its ability to resist the passage of water vapour varies according to the surrounding environment. DuPont™ AirGuard® Smart adapts to the presence of the moisture by reducing its vapour resistance and thereby allowing the moisture to migrate back into the building interior. In this case the vapour resistance can be as low as 0.26 MNs/g (sd 0.05m). Conversely, when the structure is dry and the building moisture levels are stable DuPont™ AirGuard® Smart will perform as a traditional AVCL.

Re: DuPont™ AirGuard® Control

What is DuPont™ AirGuard® Control for?

DuPont™ AirGuard® Control is an internal membrane for installation behind plasterboard linings, etc. When all joints are taped it provides a barrier to convective heat losses as well as providing limited vapour control.

Re: DuPont™ AirGuard® Reflective

What is DuPont™ AirGuard® Reflective for?

DuPont™ AirGuard® Reflective is a 100% airtight internal membrane for installation in roofs, below ceiling levels as well as in walls. When installed with a batten space DuPont™ AirGuard® Reflective will provide considerable thermal improvement to a roof or wall system. Using the product in conjunction with Tyvek® Reflex breather membrane will offer significant energy savings.

Product Data

Tyvek® Supro/Supro Plus

BBA Certificate 08/4548

Tyvek® Housewrap

BBA Certificate No 90/2548

Tyvek® Reflex

BBA Certificate 90/2548



Composition			Spunbonded polyethylene and polypropylene / Tyvek® Supro Plus includes acrylic adhesive	Spunbonded polyethylene	Spunbonded polyethylene metallised
Thickness of product (mm)			0.45	0.175	0.220
Thickness of functional layer (mm)			0.175	0.175	0.220
Weight (g/m²)			145	63	83
Roll width (m)			1.0 1.5	1.4 2.8	0.48 1.5 2.7
Roll length (m)			50	100	100
Roll weight (kg)			7.4 11.3	9 18.5	4.2 13.1 25
Rolls per pallet / box			24	20	24
Performance characteristics		Test Method	Tyvek® Supro/Supro Plus (2507B)	Tyvek® Housewrap (3060B)	Tyvek® Reflex (3583M)
Water vapour resistance (MN.s/g)	measured by BBA	BS 3177:1959	0.22	0.17	0.72
Water vapour permeability (g/m²/day)	measured by BBA	BS 3177:1959	935	1195	284
Sd (m)*		EN ISO 12572	0.015	0.01	0.03
Resistance to water penetration	measured by BBA	MOAT 27:5.1.4.2:1983 1.0m head of water	pass	pass	pass
Head of water sustained with no penetration (m)		BS EN 20811:1992 (1996) (speed 60cm/min)	2.0	1.5	2.0
Resistance to penetration of air (m³/m²/hr at 50Pa)		EN 12114	<0.25	<2	<0.05
Tensile strength (N/5cm)		EN 12311-1 (MD/XD)	300/255	310/310	250/210
Elongation (%)		EN 12311-1 (MD/XD)	13/22	17/20	10/13
Nail tear resistance (N)		EN 12310-1 (MD/XD)	175/190	55/50	90/85
Fire classification		EN 13501-1 (EN ISO 11925-2)	E**	E**	
Thermal resistance value with air space (m²K/W)			/	/	0.54
CE Certification 		EN 13859-1 and EN 13859-2	Yes	Yes	Yes

Tyvek® Soft

Tyvek® UV Facade
BRE Certificate No 155/10



Spunbonded polyethylene	Spunbonded polyethylene and polypropylene
0.175	0.60
0.175	0.22
58	195
1.4 2.7	1.5 3.0
100	50
9 17.5	16 31.5
24	24

Tyvek® Soft (1560B)	Tyvek® UV Facade (2524B)
/	/
/	/
0.015	0.035
/	/
≥1.5	3
≤0.25	<0.1
165/140	410/335
10/16	14/19
65/60	300/340
E**	E and D-s1, d2
/	/
Yes	Yes

DuPont™ AirGuard® Reflective
BBA Certificate: 90/2548 and 08/4548

DuPont™ AirGuard® Control
BBA Certificates 90/2548 and 08/4548

DuPont™ AirGuard® Smart New









Polyethylene, Spunbonded polypropylene, Aluminum	Spunbonded polypropylene and ethylen, butylacrylate copolymer coating	DuPont™ Typar® (PP), Film, spunbond PP
0.43	0.30	0.4
149	108	139
1.5	1.5	1.5
50	50	50
12.0	8.5	11
24	24	24

Test Method	DuPont™ AirGuard® Reflective (5814X)	DuPont™ AirGuard® Control (8327AD)	DuPont™ AirGuard® Smart (8407A)
Water vapour resistance (MN.s/g)	20520	≥ 10.5	0.26 - 156
Water vapour permeability (g/m²/day)	0.01	≤ 20	1.2 - 425
EN 1931	2000 (>500)	5	13
MOAT 27:5.1.4.2:1983 1.0m head of water	pass	pass	/
	/	/	/
ISO 5636/5 (Gurley)	>2000s	>2000s	>2000s
MD/XD EN 12311-2 (N/5 cm)	440/210	200/170	360/300
MD/XD EN 12311-2 (%)	25/22	38/38	30/20
EN 12310-1 (N)	247/223	240/240	310/330
EN 11925-2	E**	E	E
	0.67	/	/
EN 13984	Yes	Yes	Yes

* tested acc.to EN ISO 12572 climate C (multilayer method).
** installed on mineral wool.

Product Data

	DuPont™ Tyvek® Acrylic Tape (2060B)	DuPont™ Tyvek® Butyl Tape (1310B)	DuPont™ Tyvek® Double Sided Acrylic Tape (1310D)	DuPont™ Tyvek® Metallised Tape (2060M)	Tyvek® UV Facade Tape (1310F)	DuPont™ FlexWrap NF (FLEXNF)
						
Composition	Spunbonded polyethylene / single sided acrylic adhesive / paper release liner	100% butyl mass / paper release liner	PES/PVA-grid / acrylic adhesive / paper release liner	Spunbonded polyethylene / single sided acrylic adhesive / metallised paper release liner	Single-sided acrylic tape / high UV-stabilised Polypropylene / paper release liner	A crimped DuPont™ Tyvek® top sheet / butyl mass / paper release liner
Thickness (mm)	0.3	1.2	0.15	0.3		1.6
Weight (g/m²)	320	1560	220	320	410	1200
Roll width (mm)	75	50 20	50	75	75	150
Roll length (m)	25	30	25	25	20	22.9
Roll weight (kg)	0.7	2.5 1.0	0.3	0.7	0.7	4.5
Rolls per pallet/box	6	4 8	10	8	8	1

Applications	Tyvek® 2060B Tape	Tyvek® Metallised Tape	Tyvek® Double Sided Acrylic Tape	Tyvek® Butyl Tape	Tyvek® Flexwrap	Tyvek® UV Facade Tape
Roofing membranes						
Tyvek® Supro	✓		✓	✓	✓	
Tyvek® Enercor® Roof	✓	✓	✓	✓		
Tyvek® Metal			✓	✓		
Wall membranes						
Tyvek® Housewrap	✓		✓	✓	✓	
Tyvek® Soft	✓		✓	✓	✓	
Tyvek® UV Facade			✓	✓		✓
Tyvek® Reflex/Enercor® Wall		✓	✓	✓		
Internal AVCL's						
DuPont™ AirGuard® Control	✓		✓	✓	✓	
DuPont™ AirGuard® Reflective		✓	✓	✓		
DuPont™ AirGuard® Smart	✓		✓	✓	✓	
Materials						
Masonry/concrete/render (smooth)	✓	✓	✓	✓	✓	✓
Brick/block/concrete (rough)				✓	✓	
Plasterboard	✓	✓	✓	✓	✓	✓
Eaves Carrier			✓	✓		
Window/door frames	✓	✓	✓	✓	✓	✓
Metal surface	✓	✓	✓	✓	✓	✓
Timber (rough sawn)				✓	✓	
Timber (planed)	✓	✓	✓	✓	✓	✓
Details						
Pipe penetrations (plastic)	✓	✓			✓	✓
Pipe penetrations (metal)	✓	✓			✓	✓
Wiring/cable penetrations	✓	✓				✓
Chimneys				✓	✓	
Chimneys (making good corners)	✓	✓			✓	
Around electrical sockets	✓		✓	✓	✓	
Other						
Damage repair	✓	✓				✓
Nail penetration*				✓		
Making good	✓	✓				✓
Laps sealing	✓	✓	✓		✓	✓

* Under batten

Note: It is important to ensure that site conditions are appropriate when applying DuPont adhesive tapes. The efficiency of the adhesive to provide a suitable tack may be affected by low temperatures (below 5oC), contamination to bonding surfaces and the presence of moisture. More product specific information can be found on our website: construction.tyvek.co.uk

Tyvek® membranes wall and floor applications

General Notes

Ordering, supply and delivery

DuPont™ Tyvek® membranes and accessories are supplied and technically serviced in the UK and are available through most local and national roofing and builders merchants.

Packaging and identification

Rolls of Tyvek® membranes are individually wrapped and contain a label bearing the Tyvek® grade (eg. Tyvek® Reflex), the company name, address and telephone number, together with fixing instructions. A printed overlap line is indicated on the top outerface of the material together with a continuous identification legend: DuPont™ Tyvek®. This information is printed on the inner face of Tyvek® Reflex.

Damage

Whilst Tyvek® membranes are extremely durable there may be occasions when the membrane is damaged as a result of careless handling. Minor damage can be easily repaired with Tyvek® Acrylic Tape (single sided) applied either externally or internally or Tyvek® UV Facade should be repaired by using Tyvek® UV Facade Tape. Areas of the membrane that suffer extensive damage should be replaced, or covered with a Tyvek® patch. In this case the affected area should be covered entirely, taking care to lap the sheets correctly by a minimum 100mm horizontal laps/150mm vertical laps. Sealing the membrane can be achieved by using Tyvek® Acrylic Tape or Tyvek® Double-sided Tape or Tyvek® Butyl Tape.

Fire

The products have similar properties in relation to other polyolefinic sheets. Tyvek® membranes will melt and

shrink away from heat, but will burn in the presence of an ignition source. They will not give off any harmful gases.

Insect attack

Tyvek® membranes will not encourage attack from insects, birds or vermin.

Compatibility

Tyvek® membranes are compatible with most materials associated with the construction process, including sand/cement and lime rendering, silicone and bitumen. Fibre contraction within the membrane can sometimes occur when in contact with water or solvent based timber treatments, temporarily resulting in a loss of water resistance. This only applies to wet treatments which have been freshly applied or soaked (by rainfall). Sufficient time must be allowed for timber treatments to dry before the installation of the Tyvek® membrane.

Health and safety

In normal installation and usage Tyvek® membranes do not present a hazard under the COSHH regulations. Handling single rolls of Tyvek® does not present a risk of injury, provided recommended safe practices in lifting and handling are followed. As with paper, freshly cut edges can be sharp, but cutting the material does not produce hazardous dust. COSHH information in accordance with directive 93/112/EC is available on request.

Durability

Tyvek® membranes will retain their durability at temperatures down to -40°C and up to +100°C. Tyvek® membranes will have a service life similar to that of the building fabric which incorporates them, provided their exposure to direct sunlight does

not exceed 4 months.

Technical Support

DuPont™ Tyvek® offer a high level of technical support to assist with detailed proposals or specifications that include Tyvek® membranes. Full technical back up includes:

Telephone helpline:

discuss details and solutions with one of our technical consultants

Written confirmation:

for assistance with Building Regulations applications, warranties, acceptance of proposals and suitability of applications

Technical literature:

Agrément certificates, technical brochures and COSHH information

Site assistance:

on-site technical liaison with one of our Regional Managers

Seminars:

guidance on Tyvek® applications, control of condensation, energy efficiency and legislative compliance.

Condensation Risk Analysis:

to demonstrate compliance with the Approved Documents of the Building Regulations, condensation risk assessments in accordance with BS5250: 2011 are available on request. (See following page)

For information, please call our Technical Support Department:
01275 337660

Tyvek® membranes wall and floor applications

General Notes

Condensation Risk Analysis

In order to assess the risk of interstitial condensation a free analysis can be carried out for proposed wall or floor constructions where a Tyvek® membrane is specified. The analysis uses the calculation method contained in BS EN ISO 13788, and as referred to within Annex D of BS5250: 2011.

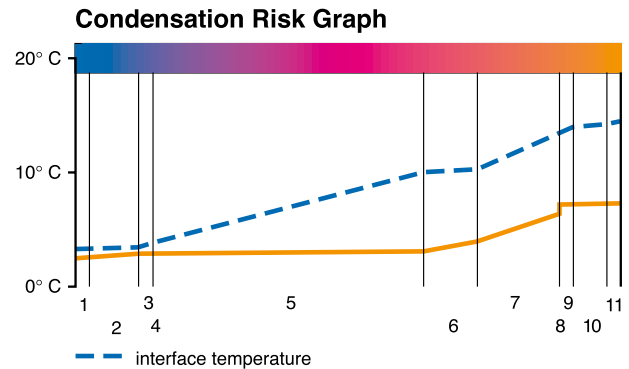

To obtain the analysis please complete this form and fax to Tyvek® Technical Support on: **01275 87 90 33**

Name & address: **Tel:**

..... **Fax:**

..... **E-mail:**

Project ref:

Building type

(please tick **one** only)

- Office/shop
- Domestic/residential
- Public/community building
- Church
- School
- Sports/activity
- Swimming pool
- Other

Wall system

(please tick **one** only)

- Timber frame
- Metal frame
- Masonry
- Stone
- Internal insulation
- External insulation
- Brick/block
- Precast concrete
- Rainscreen cladding
- Other

Floor system

(please tick **one** only)

- Suspended timber
- Block and beam
- Concrete slab
- Other

Studs/joists = mm x mm @ centres

Exposure rating (please specify) sheltered normal exposed

Construction details (please list construction build-up starting with the external layers)

- Outside 1.....
- 2.....
- 3.....
- 4.....
- 5.....
- 6.....
- 7.....
- 8.....
- Inside 9.....

Typical example:

- 102 mm brickwork
- 50 mm cavity
- Tyvek® Reflex
- 9.5 mm OSB sheathing
- 90 mm insulation
- DuPont™ AirGuard® Control vapour control layer
- 12.5mm plasterboard.

Tyvek® membranes wall and floor applications

British & European Standards

BS 3137: 1972 (95)	Methods for determining the bursting strength of paper and board
BS 3177: 1959 (95)	Method for determining the permeability of flexible sheet materials used for packaging
BS 4016: 1997	Specification for flexible building membranes (breather type)
BS EN 1107-2: 2001	Flexible sheets for water-proofing - Determination of dimensional stability plastic and rubber sheets for roof waterproofing
BS 5250: 2011	Code of practice for control of condensation in buildings
BS 5268-2: 2002	Structural use of timber - Code of practice for permissible stress design, materials and workmanship
BS 5268-3: 2006	Structural use of timber - Code of practice for trussed rafter roofs
BS EN 13859-2	Flexible sheets for waterproofing - Definitions and characteristics of underlays - Underlays for walls
BS EN 13984	Flexible sheets for waterproofing. Plastic and rubber vapour control layers. Definitions and characteristics
BS 7374: 1990	Methods of test for water vapour transmission resistance of board materials used in buildings
BS 2782: Pt 3 1976 (96)	Methods of testing plastics: Mechanical properties. Methods 320A-320F. Tensile strength, elongation and elastic modulus
BS EN ISO 6946: 1997	Building components and building elements Thermal resistance and thermal transmittance – calculation method
Moat No.27: 1983	General Directive for the assessment of roof waterproofing systems

Regulations and Technical References

- Building Regulations 2000 (as amended)
Approved Document L (L1A, L1B, L2A, L2B)

- Building Regulations 2000 (as amended)
Approved Document C (C2)

- Building (Scotland) Regulations 2004 The Scottish Building Standards (as amended):
 - > Section 3.10.1 Precipitation – General Provisions (G3.1)
 - > Section 3.15.4 Condensation – Interstitial Condensation (G4.1)
 - > Section 6.2.1 Building Insulation Envelope - Elemental Method (J3.2, J8.3)

- TRADA Wood Information Sheet 1-35

- TRADA Technology, Timber Frame Construction
(4th Edition 2007)

- CIBSE Guide A: Environmental Design (7th Edition 2006)

About DuPont



DuPont Luxembourg site

DuPont is a science company. Founded in 1802, DuPont puts science to work by solving problems and creating solutions that make people's lives better, safer and easier. Operating in more than 70 countries, the company offers a wide range of products and services to markets including agriculture, nutrition, electronics, communications, safety and protection, home and construction, transportation and apparel. Recognized as the number 1 for scientifically driven solutions, DuPont is the world's leading company in chemical technology and innovation, with more than 200 years of experience in developing and introducing very successful products (such as Corian®, Teflon®, Kevlar®, Nomex®, SentryGlas®), which have changed the lives of millions of people.

In the world of construction, DuPont developed Tyvek® 50 years ago and has more than 40 years experience in

the market with Tyvek® construction membranes, which are used extensively today in the protection of roofs and walls of millions of homes all over the world. Since its first installation, more than 15 million buildings have been protected with Tyvek® membranes worldwide. This shows that Tyvek® membranes have a well-established pedigree and are fit for purpose over the entire lifetime of the building. As part of DuPont's company culture and core values of safety and protection, DuPont protects buildings and their occupants through the use of unique and highly advanced technological materials such as Tyvek®. At the same time, DuPont also protects the environment for future generations, as Tyvek® roofs and walls are extremely efficient – cutting energy consumption, heating bills and greenhouse gas emissions to the atmosphere, and thus reducing the risk of global warming.

With one of the best R&D capabilities in the world, DuPont has an outstanding track record as a strong and reliable manufacturer with a long standing commitment to sustainable growth, meeting the specific needs and requirements of all customers, such as architects, designers, specifiers, builders, roofing contractors, etc.

DuPont is the world's largest manufacturer of breather membranes for construction. The company carries out exhaustive market research and listens to the market, applying continuous technological improvement and focusing on market development.

Contact Information

UK office address:

DuPont™ Tyvek®
Unit 29
Hither Green Estate
Clevedon, North Somerset
BS21 6XU

Tel: 01275 337660
Fax (sales): 01275 879773
Fax (technical): 01275 879033

Luxembourg office address:

DuPont de Nemours (Luxembourg) S.à.r.l.
L-2984 Luxembourg

Tel: (+352) 3666 5885
Fax: (+352) 3666 5021
Email: tyvek.construction@dupont.com

www.tyvek.co.uk

Edition 05/2012

Recommendations as to methods, use of materials and construction details are based on the experience and current knowledge of DuPont and are given in good faith as a general guide to designers, contractors and manufacturers. This information is not intended to substitute for any testing you may need to conduct to determine for yourself the suitability of our products for your particular purposes. This information may be subject to revision as new knowledge and experience becomes available. Since we cannot anticipate all variations in actual end-use conditions, DuPont makes no warranties and assumes no liability in connection with any use of this information. Nothing in this publication is to be considered as a licence to operate under a recommendation to infringe any patent right.

Tyvek® construction membranes are manufactured by DuPont under an ISO 9001:2008 Quality Assurance System.



The miracles of science™