

LCN®

1460T/1461T Series

Door controls



Fire Rated: Tested on fire door assemblies in accordance with Australian Standards, refer fire door manufacturer for specific approval details

The LCN 1460T/1461T Series is a non-handed slim line track arm closer designed for interior use on narrow head frames and top rails. The modern styling and small projection make it an excellent choice for interior doors. The LCN 1460T/1461T Series has been designed to be used on aluminium, hollow metal or wood swinging commercial interior doors and is ideally suited for apartment/hotel/motel doors or where aesthetics are of importance.

Features

- Universal, fully reversible, non-handed door closer
- Closer cylinder constructed of high strength cast iron for increased durability
- Tested to 2,000,000 cycles
- Fully adjustable spring strength to suit door size and site conditions
- 1460T factory set to strength 3
- 1461T factory set to strength 1
- Standard closer offers 3 installation options
 - Regular (pull side)
 - Top jamb (push side)
 - Stop face
- Independent adjustment valves for adjusting backcheck, closing and latching speeds
- All adjustment valves are concealed behind the cover to prevent tampering
- Stick-on template for fast, accurate installation. Cuts installation time in half
- Closers installed according to LCN installation instructions require minimal periodic maintenance or adjustments
- The 30 year warranty provides specifiers and users with assured quality and performance

Specification guide

Series	Function	Finish
LCN 1460T Series LCN1460T	Regular R	Aluminium ALUM
LCN 1461T Series LCN1461T	Hold open HO	
	Delayed action DA	

- Series
Select the desired series e.g. LCN 1461T Series LCN1461T
- Function
Select the required function LCN1461THO
- Finish
Select the desired finish e.g. Satin stainless steel LCN1461THOSSS

Selection chart

Select closer based on width of door

Model	Strength	Exterior door	Interior door
1460T	2 - 4	869mm - 965mm	660mm - 1219mm
1461T	1 - 2	NA	660mm - 864mm

Specifications

Door type	Timber or metal
Door size	1460T External door 864mm - 965mm Internal door 660mm - 1219mm 1461T Internal door 660mm - 864mm
Applications	Regular - pull side mount Top jamb - pull side mount Stop face - push side mount
Adjustment controls	Closing speed Latching speed Backcheck
Strength	1460T - 2-4 adjustable 1461T - 1-2 adjustable
Options	Hold open clip Adaptor plate Parallel arm drop plate
Finishes	Aluminium, satin stainless steel (optional cover only), polished stainless steel (optional cover only)
Warranty	30 year mechanical



The LCN 1460T is an adjustable 2-4 strength closer which is suitable for interior doors from a minimum width of 660mm to a maximum width of 1219mm under normal conditions. The LCN 1461T is an adjustable 1-2 strength closer which is suitable for interior doors from a minimum width of 660mm to a maximum width of 1219mm under normal conditions

Caution! The LCN 1461T is designed for reduced opening force which when set to a 1 strength makes it suitable for use by people who are frail, aged or disabled. This closer can operate at between 14-20Nm from initial opening up to 90°

Note Where door closers are installed and adjusted to meet reduced opening force requirements, there may be insufficient power to reliably close and latch the door, depending on prevailing operating conditions

In areas of high wind pressure and/or air conditioning pressures or doors located in exceptionally heavy traffic or oversized/heavy doors, the LCN 4041 Series closers or LCN Automatic Door Operators are recommended

Regulating controls

The LCN 1460T/1461T has independent regulators to control:

Closing speed	Adjustment to increase or decrease the speed at which the door closes. This allows the appropriate momentum to close the door in a safe and secure manner. Closing speed adjustment operates from the maximum opening to 15°
Latching speed	The latching speed allows the door to close quietly and firmly. It can be adjusted to increase or decrease the speed at which the door finally closes. This assists the final stage of the closing cycle to help overcome stubborn latchbolts or air pressure conditions. The latching speed adjustment operates from 15° to closing
Backcheck	Adjustable hydraulic backcheck provides a cushioning effect when the door is forcibly thrown open to prevent damage to the closer, door and frame. The backcheck adjustment allows the level of resistance in the latter stage of opening to be set at the level required. Backcheck is effective from 75°. Backcheck is a requirement for all fire rated closers
Delayed action	Enables door closing action to be delayed for an adjustable period of time before resuming normal closing, allowing slow moving traffic to pass through. Delay action can be adjusted up to a delay time of approximately 1 minute. Operational zone of delay is between 180° to 75°
Power adjustment	Spring strength may be increased or decreased by turning the allen head screw located in the end of the door closer body

Functions

Regular	For applications where the door must fully close after each opening
Hold open	Suitable for doors where the door may need to be left in a hold open position. The hold open function can be set to hold open at a single point from 85° to 115°. Hold open closers can not be used on fire doors
Track bumper	Cushions opening swing at maximum opening. Limits degree of opening Pull side mount 115° Top jamb mount 115° Stop face mount 100° Note: Does not replace auxiliary stop

Mounting details

Regular (pull side) mounting

Pull side mounting has a maximum opening of 180°
 The hold open clip allows the door to be held open at the following points; 85°, 90°, 95°, or 100° or 115°
 The reveal should not exceed 3mm. Top rail less than 64mm requires adaptor plate
 Adaptor plate requires a 38mm minimum top rail
 Clearance of 60mm behind door is required for 90° installation°

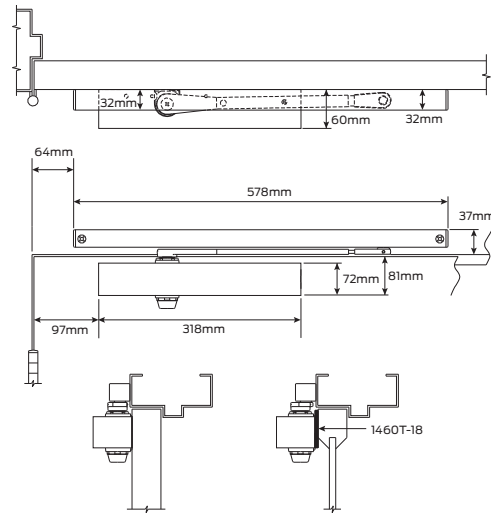

Top jamb (pull side) mounting

Top jamb mounting has a maximum opening of 180°
 The hold open clip allows the door to be held open at the following points; 85°, 90°, 95° or 100°, 110° or 115°
 The reveal on the hinge side should not exceed 3mm
 Top rail minimum is 32mm. For situations where the head frame is less than 70mm, an adaptor plate is required. Adaptor plate requires a 44mm minimum head frame

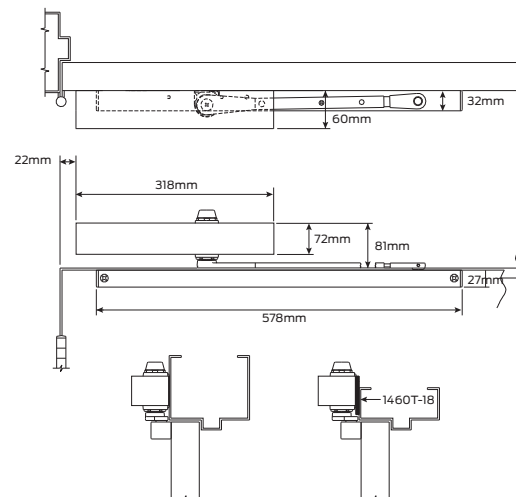

Stop face (push side) mounting

Push side mounting has a maximum opening of 110°
 The hold open clip allows the door to be held open at the following points; 85°, 90°, 95° or 100°
 The 1461T projects 60mm from door face. Top rail less than 102mm measured from the stop requires drop plate. The drop plate requires a 38mm minimum top rail. Minimum stop width is 32mm

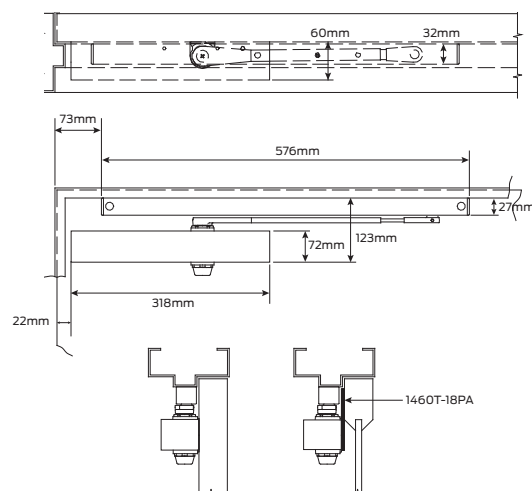

1460T & 1461T Series accessories

Track arm 1460T-3077T

Standard, non-handed arm mounts pull side, top jamb or pull side. Track roller is not included with arm
Finish: Aluminium

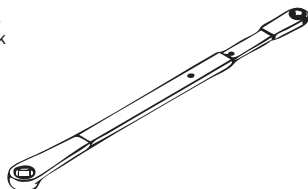

Track 1460T-3038

Non-handed, non-hold open track mounts on either side of the door
Finish: Aluminium

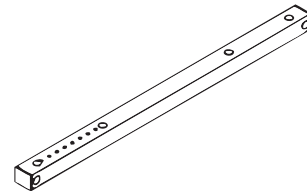

Track roller 1460T-3034

Quiet, low friction roller assembly



Hold open clip 1460T-3054

Handed clip, mounts in track to provide hold open function. Hold open point controlled by clip location

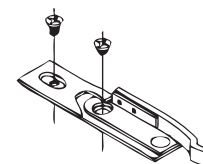

Square metal cover 1460-MC

Non-handed cover, providing complete enclosure of closer body
Finishes: Polished stainless steel, satin stainless steel

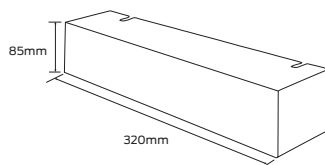

Track bumper 1460T-169

Mounts in track to assist backcheck, does not replace auxiliary stop. Limits maximum opening. Consists of bumper, bumper post and mounting screw

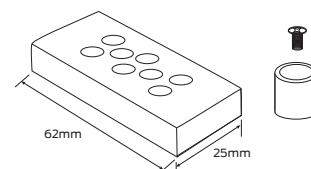

Drop plate 1460-18PAFC

Mounting plate required for parallel arm mounting configuration where top rail is less than 114mm, measured from the stop. A drop plate requires a 44mm minimum top rail

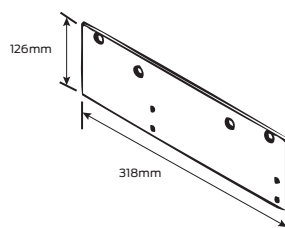

Adaptor plate 1460-18FC

Mounting plate required top jamb mounting where head frame is less than 60mm or a flush ceiling condition exists

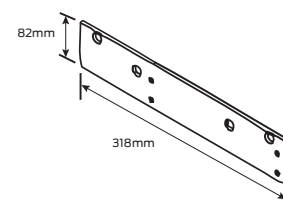



ALLEGION™

PIONEERING SAFETY™

We are
Allegion