

**MARLEY**

Large Diameter  
Stormwater Solutions

175mm — 375mm

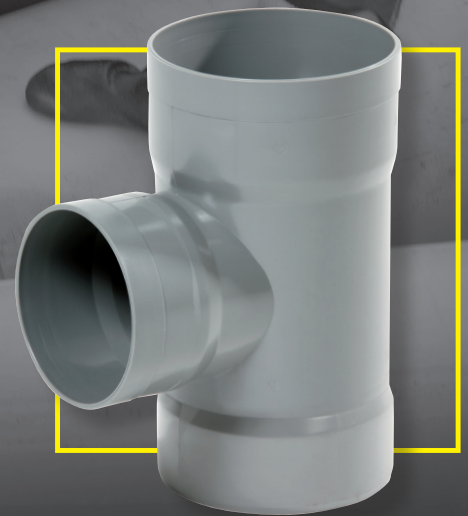

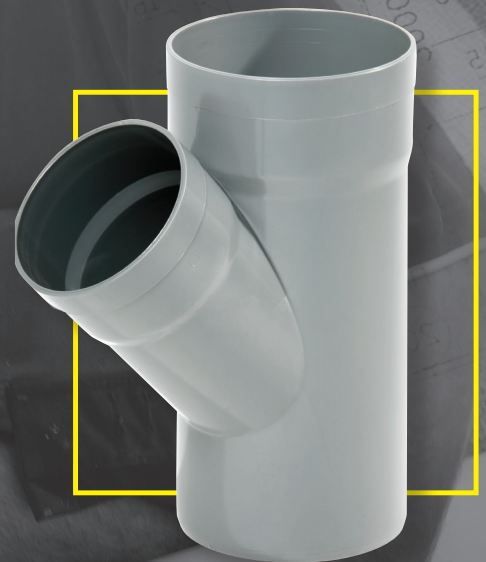

## THE MARLEY LARGE DIAMETER STORMWATER SOLUTION

Marley is proud to introduce the Large Diameter Stormwater Solution.

Marley currently manufactures a quality range of New Zealand made Large Diameter Stormline Stormwater uPVC Pipes from sizes 175mm to 375mm.

To complement this range Marley has sourced Large Diameter uPVC injection moulded fittings from two suppliers that meet our rigorous quality standards.

These two ranges of fittings when used in conjunction with Marley primers, solvents and Stormline pipe (175mm to 375mm) form our Large Diameter solution.

New Zealand customers need a system that is manufactured and/or supplied by one company with stringent quality processes in place.

An injection moulded fitting means consistent quality every time and customers need this assurance for above or below ground installations. These pipes and fittings meet the requirements of AS/NZS 1254 and are checked in our IANZ accredited laboratory.



Aymroo large diameter fittings are moulded fittings made to the AS/NZ 1254 standard.

Aymroo is an Australian company that has been manufacturing large diameter fittings for over 20 years. The range covers sizing from 225mm to 375mm fittings.

The Aymroo Range comes with a **Tapered Socket**. Marley recommends the use of Marley Solvent Joint Primer in conjunction with Marley Gold Solvent when installing the large diameter system.

The fittings can be installed above ground. Prolonged exposure to UV light can result in some loss of impact strength although changes are minor and should not reduce the systems long term performance.

For above ground systems additional UV protection can be added by applying a coat of 100% acrylic paint.



## REDI

The range of REDI large diameter fittings are designed for non-pressure applications including stormwater, commercial rainwater and rural installations. These fittings comply to the AS/NZS1254 standard.

This European range of fittings are designed and manufactured by Redi, an Italian company specialising in drainage and non-pressure solutions.

The REDI Range comes with a **Parallel Socket**. Marley recommends the use of Marley Solvent Joint Primer in conjunction with Marley Gold Solvent or a suitable gap filling cement when installing the large diameter system.

The fittings are primarily designed for buried applications. If installed above ground it is recommended to paint the fittings with a light coloured acrylic paint.

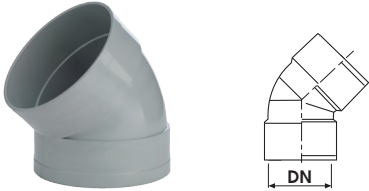
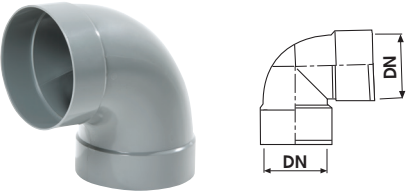
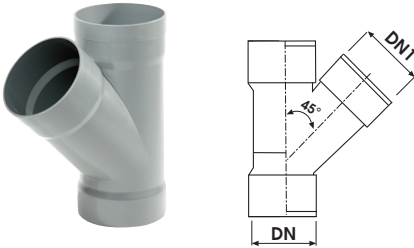
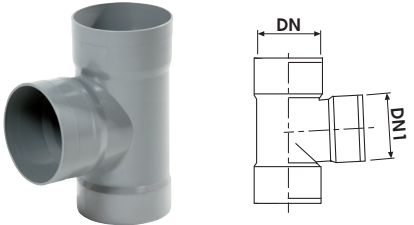

# MARLEY STORMWATER BENDS AND PLAIN JUNCTIONS (uPVC INJECTION MOULDED)

PRODUCT	PRODUCT CODE	PIPE SIZE	ANGLE	DN (ID)	DN1 (ID)
<b>BENDS</b>					
Plain Bends 45° (F&F)					
	701M.175.45 ●	175	45°	200	-
	701A.225.45 ●	225	45°	250	-
	701A.300.45 ●	300	45°	315	-
	701A.375.45 ●	375	45°	400	-
Plain Bends 90° (F&F)					
	701M.175.90 ●	175	90°	200	-
	701A.225.90 ●	225	90°	250	-
	701A.300.90 ●	300	90°	315	-
	701A.375.90 ●	375	90°	400	-
<b>PLAIN JUNCTIONS</b>					
Plain Junction 45° (F&F)					
	704M.175.45 ●	175 x 175	45°	200	200
	704A.225.45 ●	225 X 225	45°	250	250
	704A.300.45 ●	300 X 300	45°	315	315
Plain Junction 90° (F&F)					
	704M.175.90 ●	175 x 175	90°	200	200
	704A.225.90 ●	225 X 225	90°	250	250
	704A.300.90 ●	300 X 300	90°	315	315

- Amyroo fittings are suitable for above ground use and have a tapered socket (see page 2 for clarification)
- REDI fittings need to be painted if installed above ground and have a parallel socket (see page 2 for clarification)

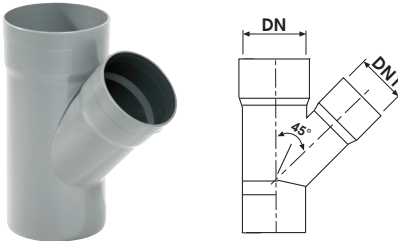
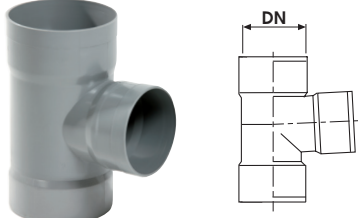
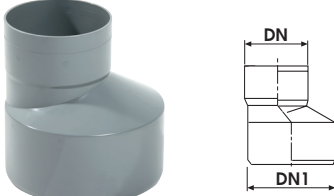

# MARLEY STORMWATER REDUCING JUNCTIONS AND LEVEL INVERT REDUCERS (uPVC INJECTION MOULDED)

PRODUCT	PRODUCT CODE	PIPE SIZE	ANGLE	DN (ID)	DN1 (ID)
<b>REDUCING JUNCTIONS</b>					
Reducing Junction 45°					
	704M.175.100.45MF ●	175 x 100	45°	200	110
	704M.175.150.45MF ●	175 x 150	45°	200	160
	704A.225.150.45 ●	225 x 150	45°	250	160
	704M.225.175.45MF ●	225 x 175	45°	250	200
Reducing Junction 90°					
	704M.175.150.90FF ●	175 x 150	90°	200	160
<b>LEVEL INVERT</b>					
Level Invert Taper Stormwater SCJ M+F (Level Invert Reducer)				DN (OD)	
	723.175.100 ●	175 x 100	-	200	110
	723M.175.150 ●	175 X 150	-	200	160
	723M.225.100 ●	225 X 100	-	250	110
	723A.225.150 ●	225 X 150	-	250	160
	723M.225.175 ●	225 x 175	-	250	200
	723A.300.150 ●	300 X 150	-	315	160
	723M.300.175 ●	300 x 175	-	315	200
	723A.300.225 ●	300 x 225	-	315	250
	723A.375.150 ●	375 X 150	-	400	160

- Amyroo fittings are suitable for above ground use and have a tapered socket (see page 2 for clarification)
- REDI fittings need to be painted if installed above ground and have a parallel socket (see page 2 for clarification)

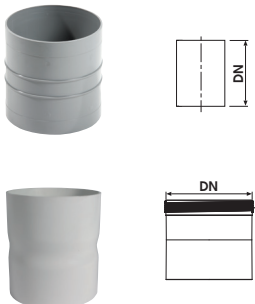

# MARLEY STORMWATER COUPLERS AND END CAPS

(uPVC INJECTION MOULDED)

PRODUCT	PRODUCT CODE	PIPE SIZE	ANGLE	DN (ID)	DN1 (ID)	
COUPLERS						
Slip Coupling Stormwater SCJ F+F (Repair Coupling)						
	710M.175 ●	175mm	-	200	-	
	710M.225 ●	225mm	-	250	-	
	710M.300 ●	300mm	-	315	-	
	Stop Couplers					
	710A.225 ●	225mm	-	250	-	
	710A.300 ●	300mm	-	315	-	
END CAP						
End Cap SCJ F						
	737M.175 ●	175mm	-	200	-	
	737A.225 ●	225mm	-	250	-	
	737A.300 ●	300mm	-	315	-	

## STORMWATER & DUCTING PIPES



Marley Stormline uPVC pipes are made in New Zealand to the AS/NZS 1254 standard and come with proprietary primers, solvents and joint lubricants.

STORMLINE SOLID WALL PIPE (SN4)	PRODUCT CODE	DESCRIPTION	CRATE QUANTITY
SOLVENT JOINT			
	700.175.6	175DN STORMLINE PIPE 6SJ	10
	RUBBER RING JOINT		
	700.175.6RJ	175DN STORMLINE PIPE 6RJ	10
	700.225.6RJ	225DN STORMLINE PIPE 6RJ	8
	700.300.6RJ	300DN STORMLINE PIPE 6RJ	6
	700.375.6RJ	375DN STORMLINE PIPE 6RJ	6

- Amyroo fittings are suitable for above ground use and have a tapered socket (see page 2 for clarification)
- REDI fittings need to be painted if installed above ground and have a parallel socket (see page 2 for clarification)

# ACCESSORIES AND JOINTING PROCEDURES FOR TAPERED AND PARALLEL SOCKETS

## ACCESSORIES

PRODUCT	PRODUCT CODE	DESCRIPTION
<b>MARLEY "GOLD"</b> (AS/NZS 3879) 	MG125	MARLEY GOLD 125ml
	MG250	MARLEY GOLD 250ml
	MG500	MARLEY GOLD 500ml
	MG4000	MARLEY GOLD 4 litre
<b>Solvent Joint Primer (Pink Tint)</b> (AS/NZS 3879) 	CF500	MARLEY JOINT PRIMER 500ml
	CF4000	MARLEY JOINT PRIMER 4 litre
<b>Joint Lubricant</b> 	JL250	RRJ LUBRICANT 275ml (TUBE)
	JL500	RRJ LUBRICANT 500ml
	JL2000	RRJ LUBRICANT 2 litre

## SOLVENT JOINTING PROCEDURES

- Minimise the number of joints.
- Make sure there are no deflections or strain on the pipe, fittings or joints.
- Check pipes have not been damaged during transit.
- Cut the pipes with a fine tooth hack saw. Ensure the pipe spigot is cut square, taking care not to chip or crack the pipe. Remove all burrs from the inside. Make a 15° chamfer to the outside of the cut end of the pipe to remove any other burrs.
- Mark the insertion depth on the pipe spigot. The insertion depth is equivalent to the depth of the corresponding joint socket. The pipe should be marked with a soft pencil or felt pen which does not damage the pipe.
- Dry assemble all pipes and joints. Check that all joints have a full interference fit. Interference fit means that the pipe spigot should not be able to fully penetrate the socket up to the insertion mark without force.
- Mark the pipe and spigot for alignment by drawing a horizontal line across the joint with a soft pencil or felt pen.
- Ensure the pipe spigot and socket are free of dust, dirt and grease.
- Lightly scuff with a clean 120 Emery cloth or sandpaper before priming. Prepare the pipe spigot and socket with Marley primer fluid using a cotton rag. Wipe the surfaces firmly, to remove all dirt and the glossy surface on both the spigot and socket.
- Apply an even coat of Marley Gold Solvent Cement to both the pipe spigot and socket. As a guide, the brush should be approximately one third to one half the pipe diameter and large enough to apply the solvent cement to both spigot and socket in about thirty seconds. Use Marley Gold PVC Solvent Cement which has not passed its use-by date.
- It is imperative that the solvent cement is in good condition. Old or contaminated cement should be carefully discarded in accordance with Local Body Regulations.
- The jointed surfaces must be softened (dissolved) and made semi-fluid by the cement.
- Sufficient cement must be applied to spigot and socket to fill the gap.
- Assembly of the pipe and fitting must be made while the surfaces are still wet and fluid.
- Hold the joint at the fully inserted position for 30 seconds. Pipes 100DN and larger may need to be mechanically inserted and held as the solvent bonds.
- Do not flex or disturb the joint for a further 15 minutes and handle with extreme care for at least another hour.
- Use sufficient cement to fill gaps and wipe off the excess solvent cement from the outside of the joint and, where possible, from the inside. Ensure excessive solvent is not left in the pipe or joint.
- Allow the joint to cure for 24 hours. Do not fill the pipeline with water until at least 1 hour after making the last joint. Do not pressurize for at least 24 hours after making the last joint.

For safety precautions and special considerations see the Marley DWV Technical Manual pages 39 and 40.

## ADDITIONAL MARLEY STORMWATER FITTINGS AVAILABLE

Marley have access to a wide range of large diameter uPVC injection moulded stormwater fittings, if you can't find what you need in this brochure please contact Marley on 0800 MARLEY (0800 627 539).

## DWV LARGE DIAMETER OPTIONS AVAILABLE ON REQUEST

**Disclaimer:** This brochure has been compiled by Marley New Zealand Limited ("The Company") to promote better understanding of the Company's products. The brochure is supplied subject to acknowledgment of the following conditions: The brochure is protected by Copyright and may not be copied or reproduced in any form or by any means in whole or in part without prior consent in writing by the Company. Product specifications, usage data and advisory information may change from time to time with advances in research and field experience. The Company reserves the right to make such changes at any time without notice. Correct use of the Company's products involve engineering judgments which cannot be properly made without full knowledge of all the conditions pertaining to each specific installation. The Company expressly disclaims all and any liability to any person whether supplied with this publication or not in respect of anything and of the consequences of anything done or omitted to be done by any such person in reliance whether whole or partial upon the whole or any part of the contents of this publication. No offer to trade, nor any conditions of trading, are expressed or implied by the issue or content of this brochure. Nothing herein shall override the Company's Conditions of Sale, which may be obtained from the Registered Office or any Sales Office of the Company. This brochure is and shall remain the property of the Company, and shall be surrendered on demand to the Company. For full details visit [www.marley.co.nz](http://www.marley.co.nz)

#### AUCKLAND

Mahia Road, Manurewa, Private Bag 802 Manurewa  
Sales Department: Telephone 09 279 2777  
Direct Fax 09 279 2778 Freefax 0800 652 621  
Head Office: Telephone 09 279 2799 Fax 09 279 2798

#### CHRISTCHURCH

Shands Road, Hornby, PO Box 16233 Christchurch.  
Contact Centre: 0800 222 922

For more information call free  
**FREEPHONE 0800 MARLEY (0800 627 539)**

MAR2900 SEPT 2017

For more information: **FREEPHONE 0800 MARLEY (0800 627539)**

[www.marley.co.nz](http://www.marley.co.nz)

an *Aliaxis* company

Plumbing and Drainage Solutions

