

Marley Untrapped Rainwater Gulley

- New modular shape with unique removable components.

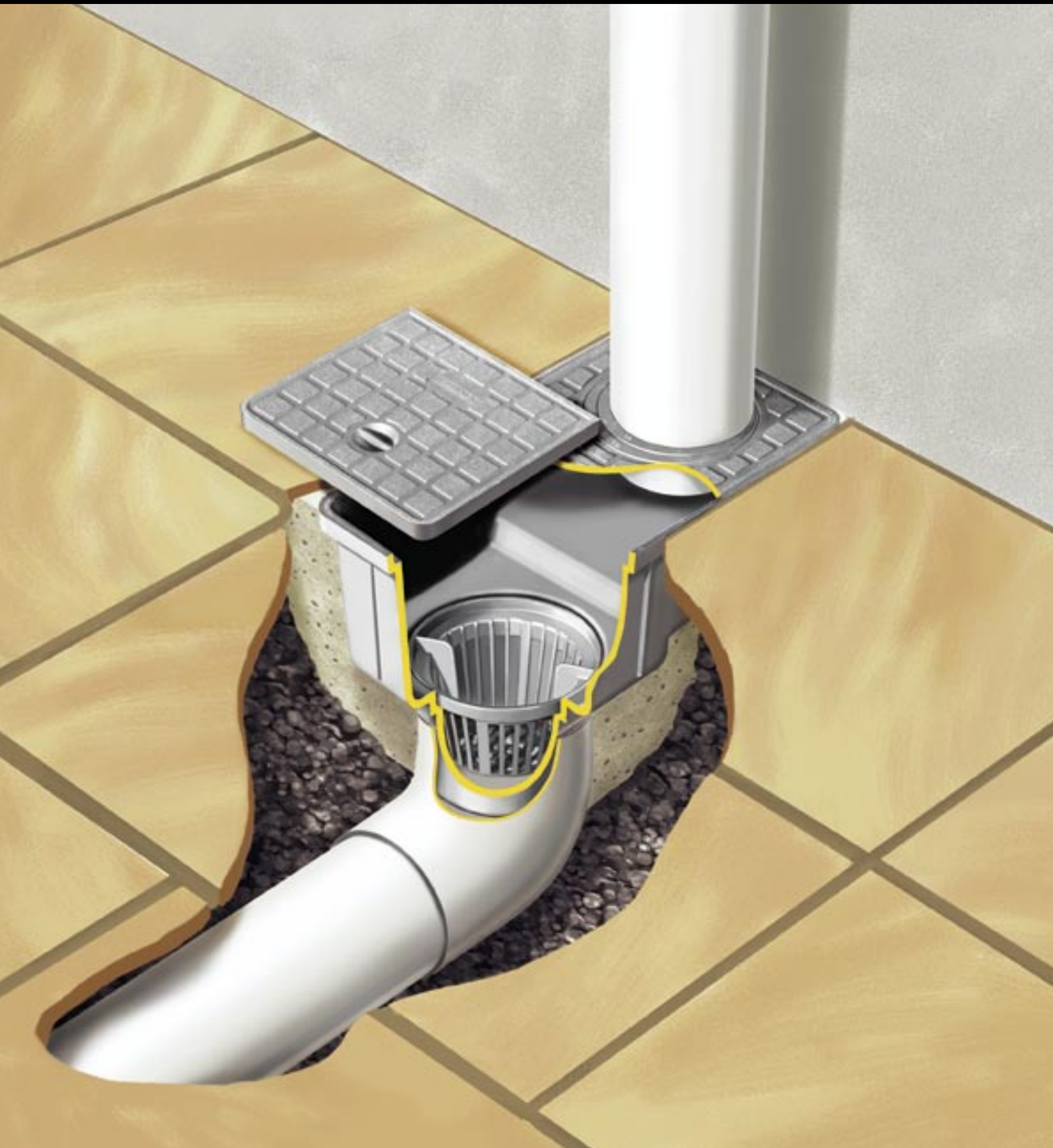

Marley Untrapped Rainwater Gulley

- New modular shape with unique removable components.

The Untrapped Rainwater Gulley is used to collect rainwater from the downpipe and channel it into the stormwater system*.

The Rainwater Gulley has a two piece removable lid, removable debris basket and 3 sizes of knockout to suit different downpipe diameters.

The modular shape allows for neat and aesthetically pleasing installation into tiles, cobbled and paved areas.

*Check with your local authority prior to installation to check compliance.

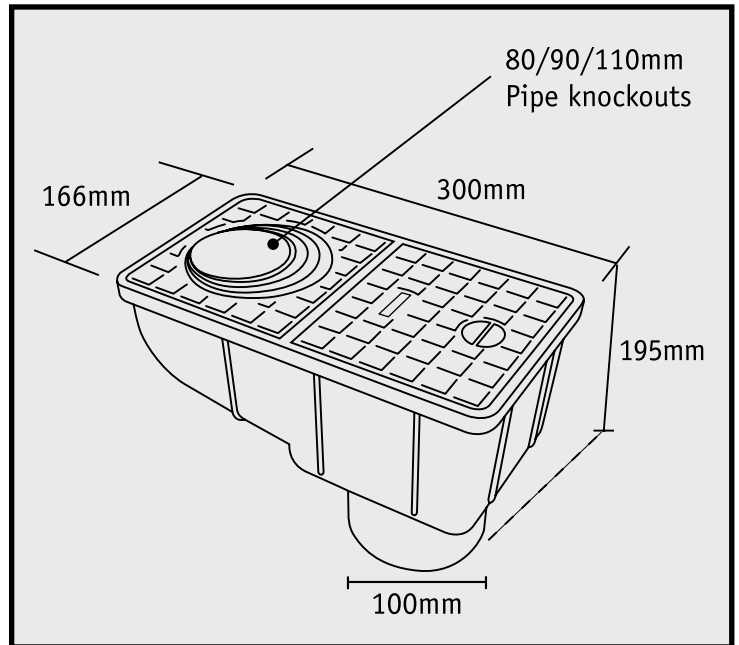

Ordering Information

Product code	Description
1SD6166	Untrapped Gulley for rainwater drainage

DISCLAIMER

This brochure has been compiled by Marley New Zealand Limited ("The Company") to promote better understanding of the technical aspects of the Company's products to assist users in obtaining from them the best possible performance. The brochure is supplied subject to acknowledgment of the following conditions: The brochure is protected by Copyright and may not be copied or reproduced in any form or by any means in whole or in part without prior consent in writing by the Company. Product specifications, usage data and advisory information may change from time to time with advances in research and field experience. The Company reserves the right to make such changes at any time without notice. Correct usage of the Company's products involve engineering judgements which cannot be properly made without full knowledge of all the conditions pertaining to each specific installation. The Company expressly disclaims all and any liability to any person whether supplied with this publication or not in respect of anything and of the consequences of anything done or omitted to be done by any such person in reliance whether whole or partial upon the whole or any part of the contents of this publication. No offer to trade, nor any conditions of trading, are expressed or implied by the issue or content of this brochure. Nothing herein shall override the Company's Conditions of Sale, which may be obtained from the Registered Office or any Sales Office of the Company. This brochure is and shall remain the property of the Company, and shall be surrendered on demand to the Company.

AUCKLAND

Mahia Road, Manurewa,
Private Bag 802 Manurewa
Sales Department: Telephone 09 279 2777
Direct Fax 09 279 2778 Freefax 0800 652 621
Head Office: telephone 09 279 2799
Fax 09 279 2798
Sales Hotline: 0800 222 922

CHRISTCHURCH

Shands Road, Hornby, PO Box 16233 Christchurch
Sales Hotline: 0800 222 922

For further information: **0800 MARLEY** (0800 627 539) www.marley.co.nz

an *OAliaxis* company

www.marley.co.nz

MARLEY