

COVER SHEET

KS1000 RW _STD WALL_HORIZONTAL Q4_2020				
DATE	DETAIL NAME	DRG_REF	REVISION	APPROVED
24.09.20	COVER SHEET	RW_HS_00	-	JS
24.09.20	PANEL DIMENSIONS	RW_HS_01	-	JS
24.09.20	PRIMARY FIXING LOCATIONS	RW_HS_02	-	JS
24.09.20	BASE DETAILS_1	RW_HS_03	-	JS
24.09.20	BASE DETAILS_2	RW_HS_04	-	JS
24.09.20	EXTERNAL CORNER DETAIL 1	RW_HS_05	-	JS
24.09.20	INTERNAL CORNER DETAIL	RW_HS_06	-	JS
24.09.20	ABUTMENTS TO CONCRETE	RW_HS_07	-	JS
24.09.20	TOPHAT JOIN DETAIL	RW_HS_08	-	JS
24.09.20	COVER CAP DETAIL	RW_HS_09	-	JS
24.09.20	RW HORIZONTAL TO VERTICAL BREAK DETAIL	RW_HS_10	-	JS
24.09.20	HORIZONTAL WINDOW DETAIL	RW_HS_11	-	JS
24.09.20	PERSONNEL DOOR DETAIL	RW_HS_12	-	JS
24.09.20	OVERHEAD DOOR DETAIL	RW_HS_13	-	JS
24.09.20	LOUVRE DETAIL	RW_HS_14	-	JS
24.09.20	PIPE PENETRATION DETAIL	RW_HS_15	-	JS
24.09.20	EAVES GUTTER DETAIL	RW_HS_16	-	JS
24.09.20	KS1100 CS GUTTER, KS1000 RW ROOF & HORIZONTAL PARAPET WALL	RW_HS_17	-	JS

SYSTEM KS1000 RW _STD WALL_HORIZONTAL Q4_2020			
DESCRIPTION COVER SHEET			
APPROVED BY JS	DATE 24.09.20	REVISION -	
DRG REF: RW_HS_00	SCALE 1:1	SHEET 1 of 1	PAPER SIZE A4

This document remains the property of Kingspan Ltd under copyright laws. Licence is granted to use this document and its contents in connection with Kingspan Ltd products only.
©Kingspan Ltd

DO NOT SCALE. IF IN DOUBT ASK

New Zealand: Kingspan Ltd
97 Montreal St
Christchurch
Tel: 03 358 7536
Fax: 03 358 7539
Freephone: 0800 121280
email: tech@kingspanpanels.co.nz
www.kingspanpanels.co.nz

Kingspan
Insulated Panels

PANEL DIMENSIONS

NOTE: ABOVE DIMENSIONS ARE NOMINAL, ACTUAL DIMENSIONS WILL VARY DUE TO MANUFACTURING TOLERANCES. EXACTLY PRECISE DIMENSIONS MUST ALWAYS BE MEASURED FROM ACTUAL SAMPLES ALL DIMENSIONS IN MILLIMETRES.

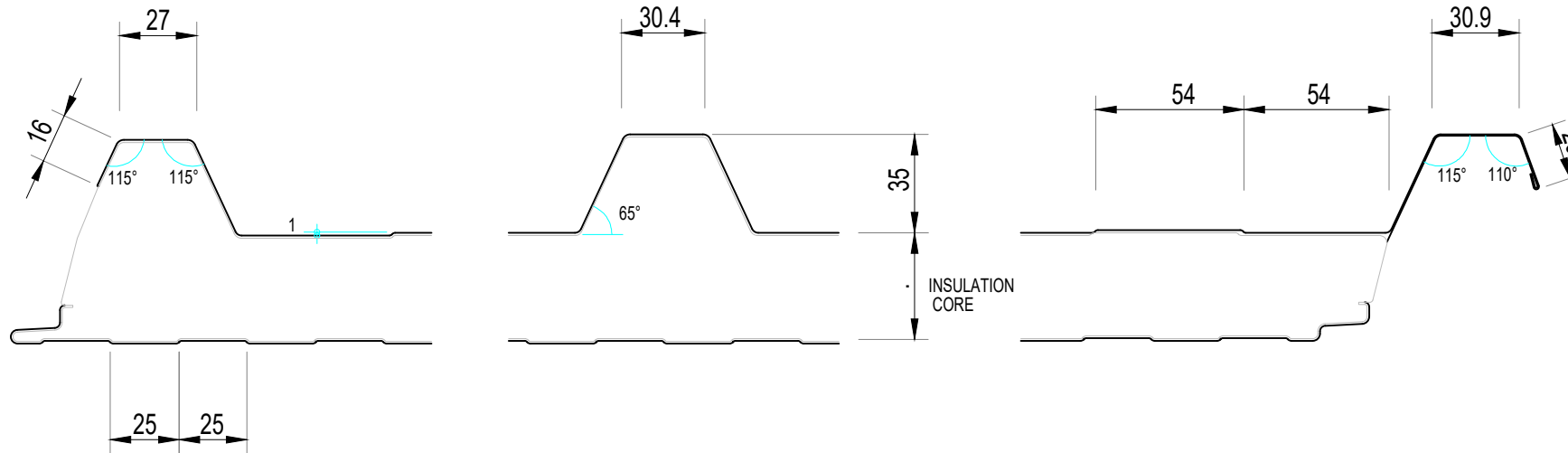
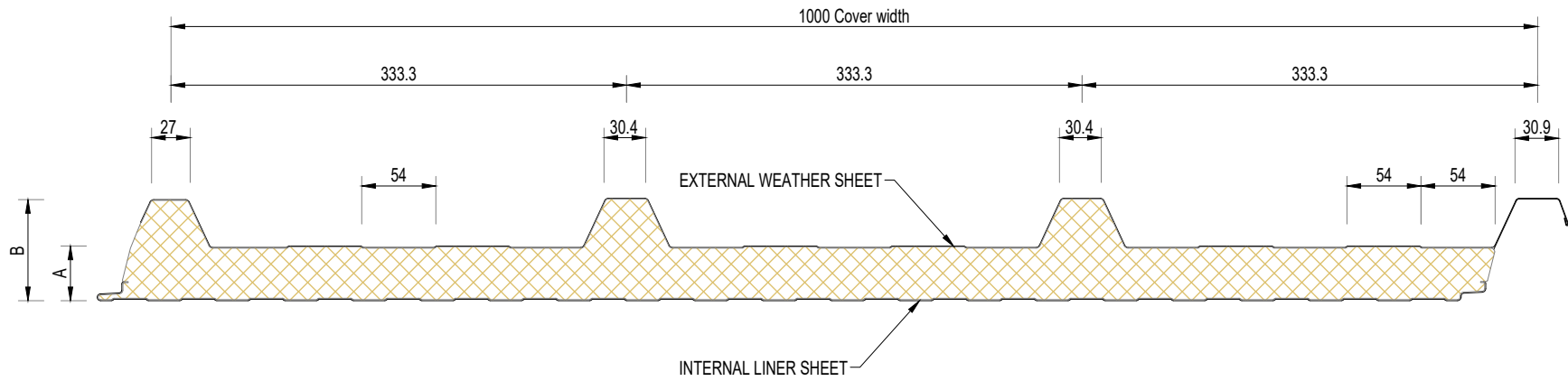

SYSTEM KS1000 RW_STD WALL_HORIZONTAL Q4_2020			
DESCRIPTION PANEL DIMENSIONS			
APPROVED BY JS	DATE 24.09.20	REVISION -	
DRG REF: RW_HS_01	SCALE 1:5	SHEET 1 of 1	PAPER SIZE A4

This document remains the property of Kingspan Ltd under copyright laws. Licence is granted to use this document and its contents in connection with Kingspan Ltd products only.
©Kingspan Ltd

DO NOT SCALE. IF IN DOUBT ASK

New Zealand: Kingspan Ltd
97 Montreal St
Christchurch
Tel: 03 358 7536
Fax: 03 358 7539
Freeophone: 0800 121280
email: tech@kingspanpanels.co.nz
www.kingspanpanels.co.nz

AVAILABLE PANEL THICKNESSES					
A- Core Thickness (mm)	40.00	60.00	70.00	100.00	120.00
B- Overall Dimension (mm)	75.00	95.00	110.00	135.00	155.00
Weight kg/m2 0.5/0.4 Steel	10.3	10.70	11.1	12.3	13.1
Thermal Insulation 'R'_Value - m ² K / W m ² K/W Calculated at K = 0.020 W/m ²	2.39	3.44	3.96	5.50	6.53

PRIMARY FIXING LOCATIONS

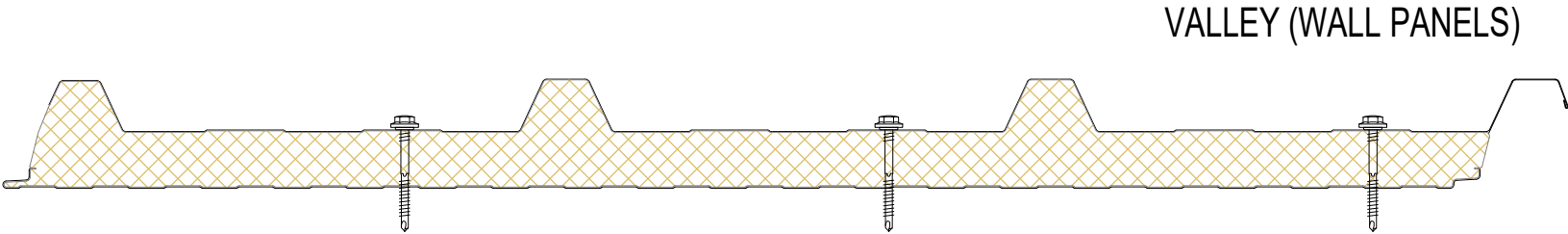

KS1000 RW WALL PANEL PRIMARY FIXING LOCATIONS.
HORIZONTALLY OR VERTICALLY LAID

SYSTEM KS1000 RW_STD WALL_HORIZONTAL Q4_2020			
DESCRIPTION PRIMARY FIXING LOCATIONS			
APPROVED BY JS	DATE 24.09.20	REVISION -	
DRG REF: RW_HS_02	SCALE 1:5	SHEET 1 of 1	PAPER SIZE A4

This document remains the property of Kingspan Ltd under copyright laws. Licence is granted to use this document and its contents in connection with Kingspan Ltd products only.
©Kingspan Ltd

DO NOT SCALE. IF IN DOUBT ASK

New Zealand: Kingspan Ltd
97 Montreal St
Christchurch
Tel: 03 358 7536
Fax: 03 358 7539
Freephone: 0800 121280
email: tech@kingspanpanels.co.nz
www.kingspanpanels.co.nz

Kingspan.
Insulated Panels

BASE DETAILS_1

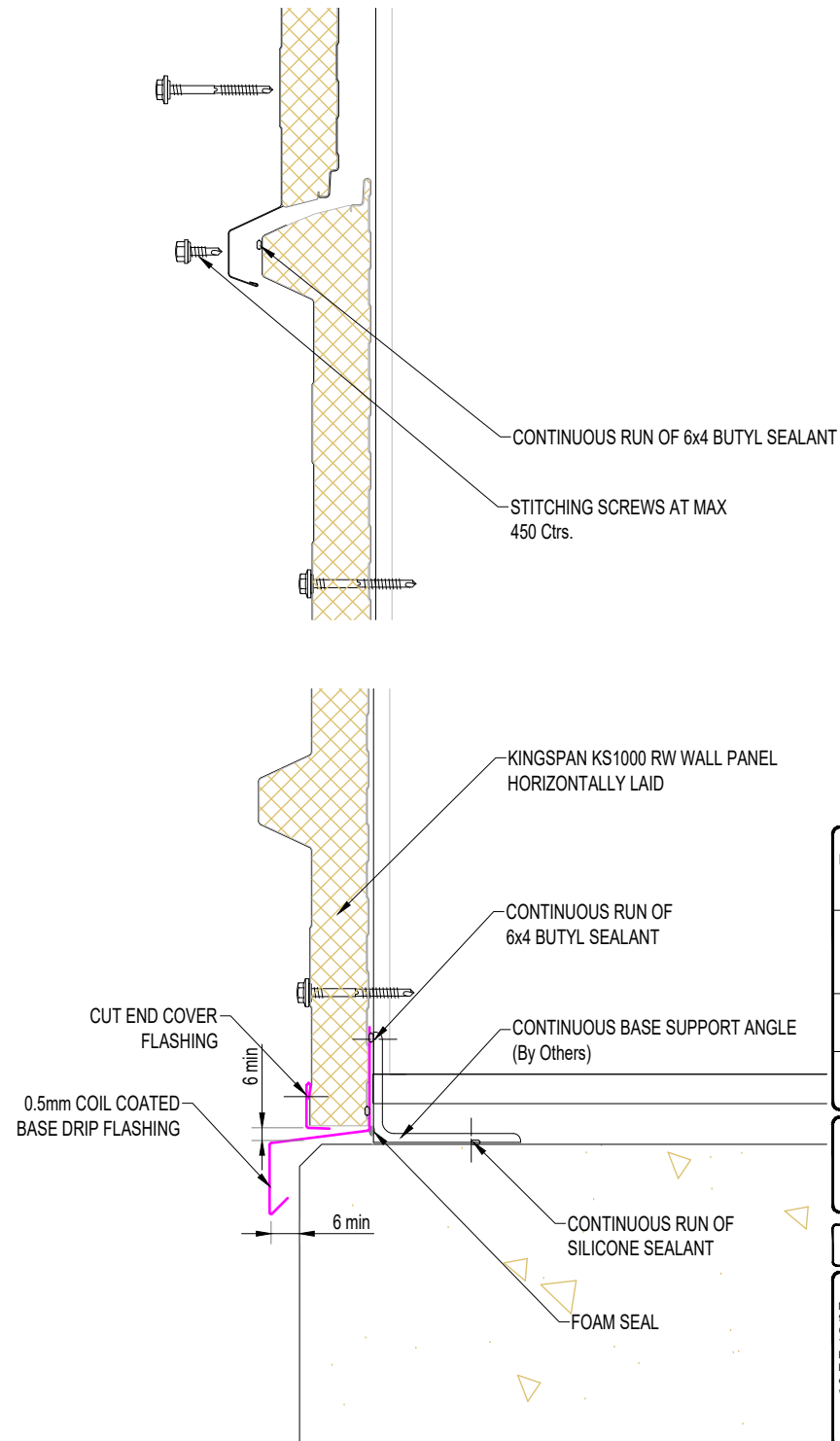
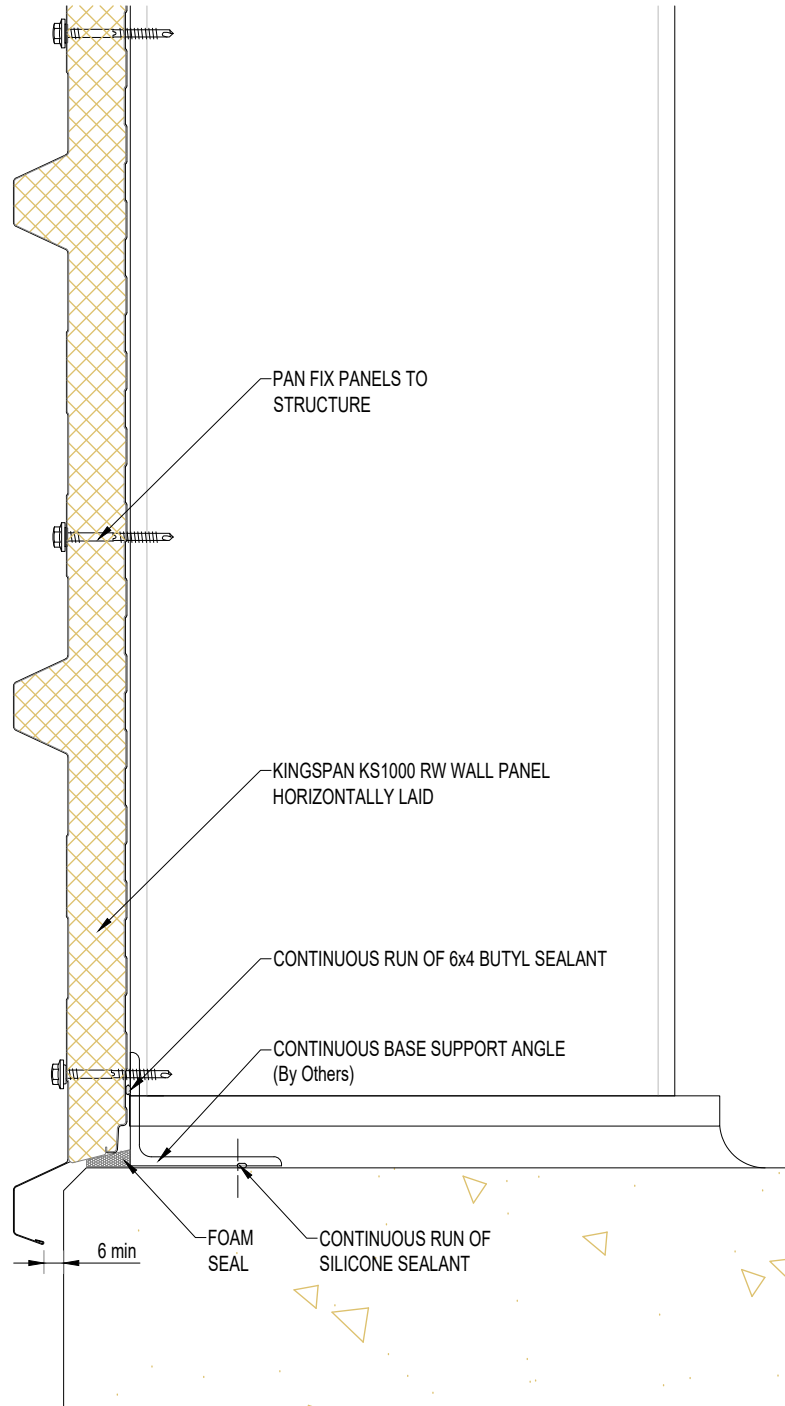

SYSTEM KS1000 RW_STD WALL_HORIZONTAL Q4_2020			
DESCRIPTION BASE DETAILS_1			
APPROVED BY JS	DATE 24.09.20	REVISION -	
DRG REF: RW_HS_03	SCALE 1:5	SHEET 1 of 1	PAPER SIZE A4
This document remains the property of Kingspan Ltd under copyright laws. Licence is granted to use this document and its contents in connection with Kingspan Ltd products only. ©Kingspan Ltd			

DO NOT SCALE. IF IN DOUBT ASK

New Zealand: Kingspan Ltd
97 Montreal St
Christchurch
Tel: 03 358 7536
Fax: 03 358 7539
Freephone: 0800 121280
email: tech@kingspanpanels.co.nz
www.kingspanpanels.co.nz

Kingspan.
Insulated Panels

BASE DETAILS_2

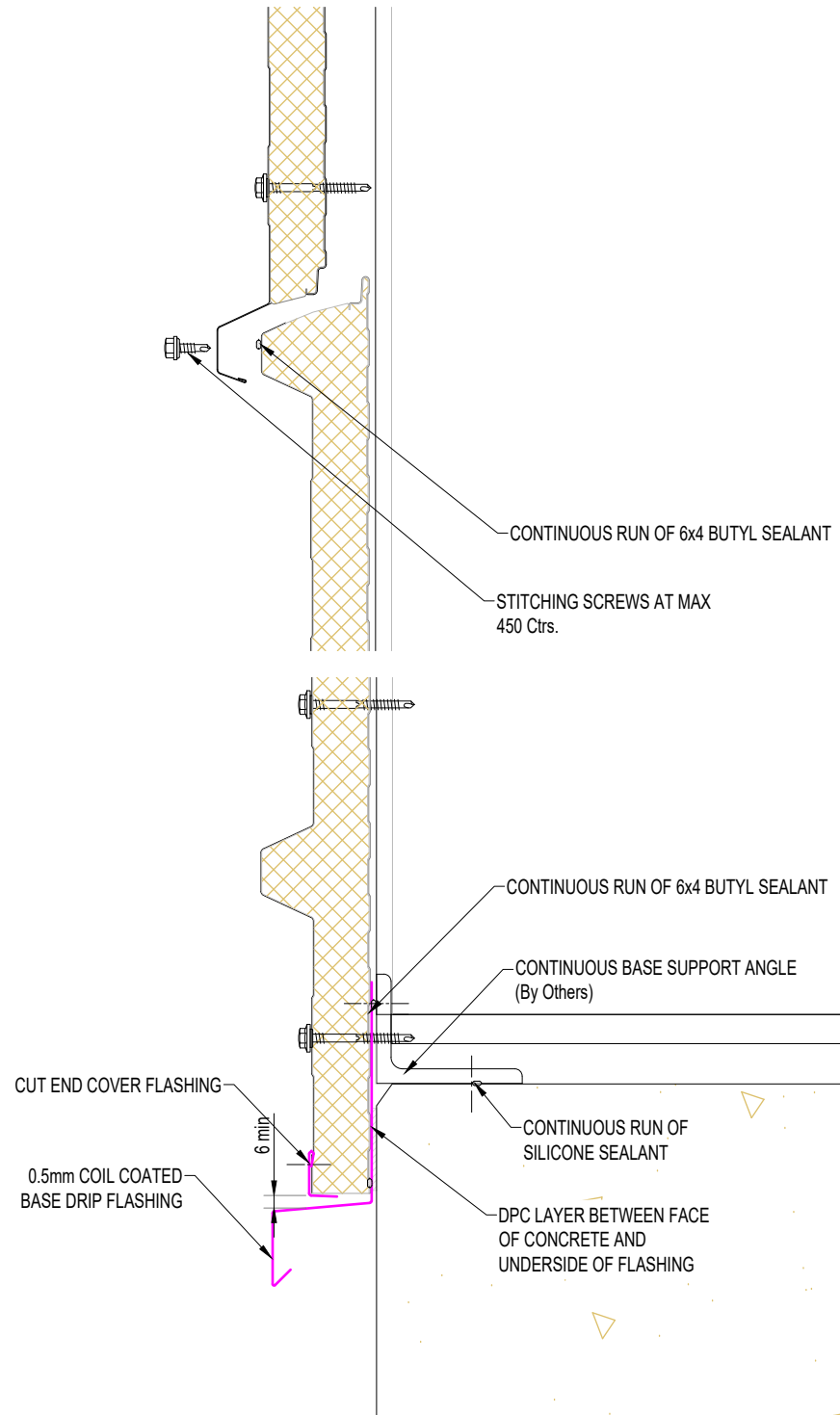
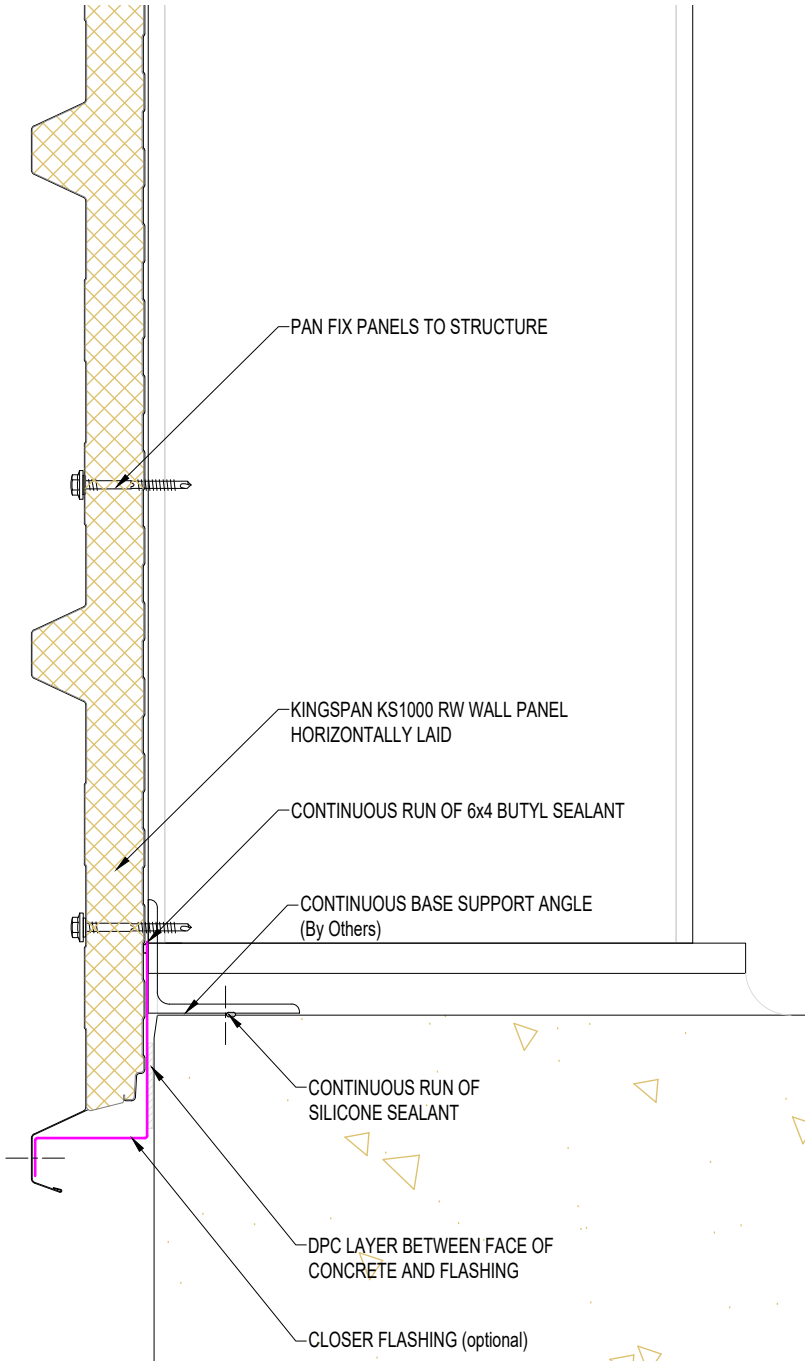

SYSTEM KS1000 RW_STD WALL_HORIZONTAL Q4_2020			
DESCRIPTION BASE DETAILS_2			
APPROVED BY JS	DATE 24.09.20	REVISION -	
DRG REF: RW_HS_04	SCALE 1:5	SHEET 1 of 1	PAPER SIZE A4

This document remains the property of Kingspan Ltd under copyright laws. Licence is granted to use this document and its contents in connection with Kingspan Ltd products only.
©Kingspan Ltd

DO NOT SCALE. IF IN DOUBT ASK

New Zealand: Kingspan Ltd
97 Montreal St
Christchurch
Tel: 03 358 7536
Fax: 03 358 7539
Freephone: 0800 121280
email: tech@kingspanpanels.co.nz
www.kingspanpanels.co.nz

Kingspan.
Insulated Panels

EXTERNAL CORNER/DETAIL 1

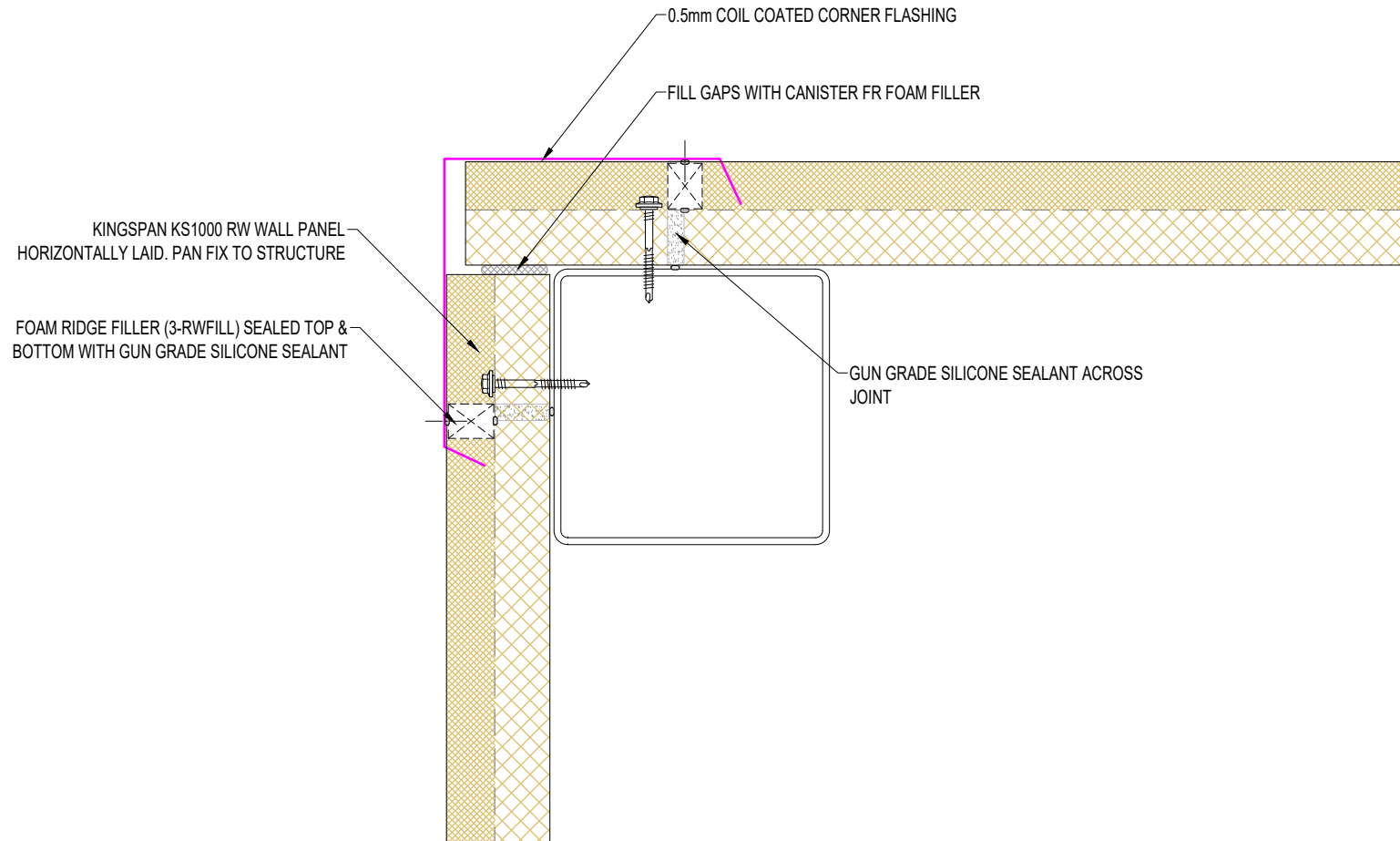

SYSTEM KS1000 RW_STD WALL_HORIZONTAL Q4_2020			
DESCRIPTION EXTERNAL CORNER DETAIL 1			
APPROVED BY JS	DATE 24.09.20	REVISION -	
DRG REF: RW_HS_05	SCALE 1:5	SHEET 1 of 1	PAPER SIZE A4

This document remains the property of Kingspan Ltd under copyright laws. Licence is granted to use this document and its contents in connection with Kingspan Ltd products only.
©Kingspan Ltd

DO NOT SCALE. IF IN DOUBT ASK

New Zealand: Kingspan Ltd
97 Montreal St
Christchurch
Tel: 03 358 7536
Fax: 03 358 7539
Freephone: 0800 121280
email: tech@kingspanpanels.co.nz
www.kingspanpanels.co.nz



INTERNAL CORNER DETAIL

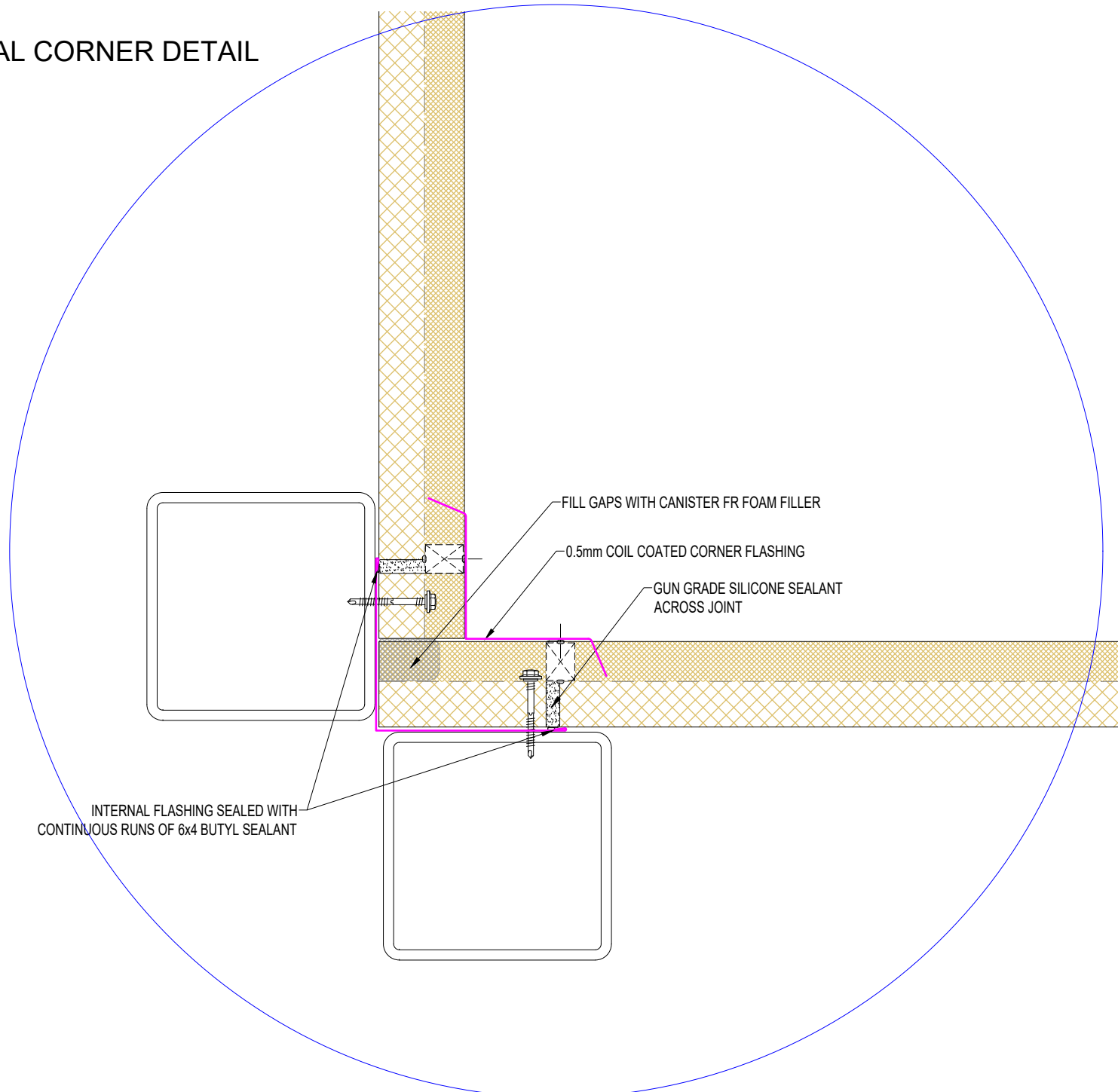

INTERNAL FLASHING SEALED WITH CONTINUOUS RUNS OF 6x4 BUTYL SEALANT

FILL GAPS WITH CANISTER FR FOAM FILLER

0.5mm COIL COATED CORNER FLASHING

GUN GRADE SILICONE SEALANT ACROSS JOINT

SYSTEM KS1000 RW_STD WALL_HORIZONTAL Q4_2020			
DESCRIPTION INTERNAL CORNER DETAIL			
APPROVED BY JS	DATE 24.09.20	REVISION -	
DRG REF: RW_HS_06	SCALE 1:5	SHEET 1 of 1	PAPER SIZE A4

This document remains the property of Kingspan Ltd under copyright laws. Licence is granted to use this document and its contents in connection with Kingspan Ltd products only.
©Kingspan Ltd

DO NOT SCALE. IF IN DOUBT ASK

New Zealand: Kingspan Ltd
97 Montreal St
Christchurch
Tel: 03 358 7536
Fax: 03 358 7539
Freephone: 0800 121280
email: tech@kingspanpanels.co.nz
www.kingspanpanels.co.nz

ABUTMENTS TO CONCRETE

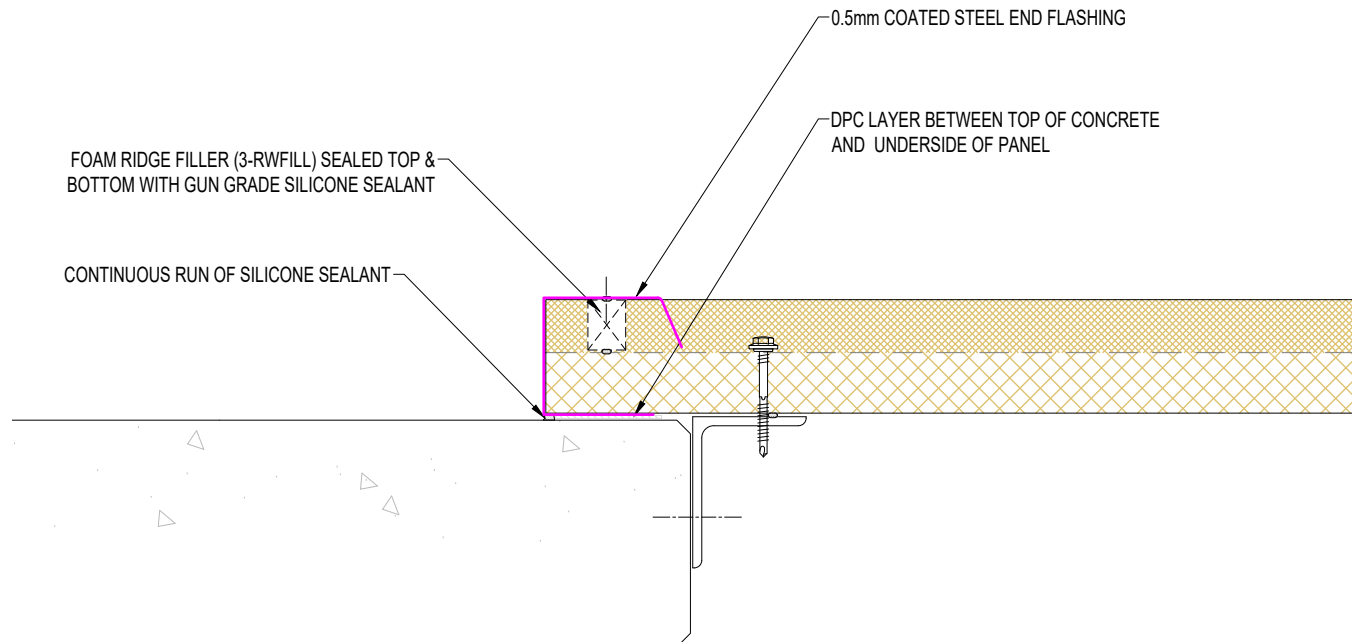
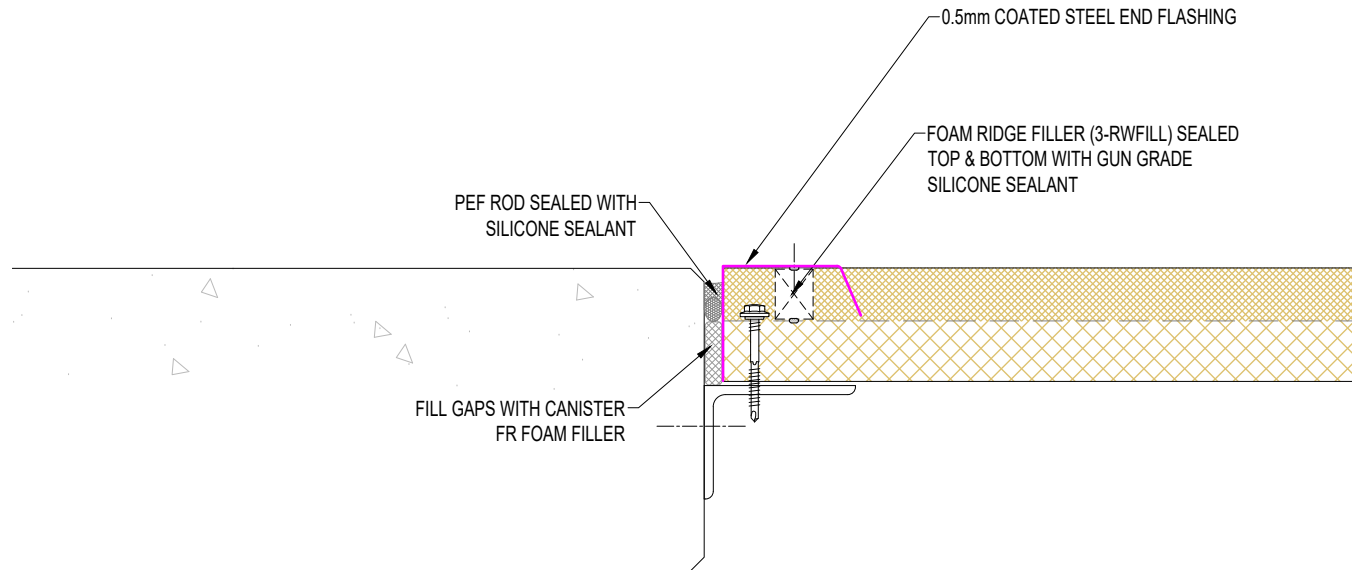

SYSTEM KS1000 RW_STD WALL_HORIZONTAL Q4_2020			
DESCRIPTION ABUTMENTS TO CONCRETE			
APPROVED BY JS	DATE 24.09.20	REVISION -	
DRG REF: RW_HS_07	SCALE 1:5	SHEET 1 of 1	PAPER SIZE A4

This document remains the property of Kingspan Ltd under copyright laws. Licence is granted to use this document and its contents in connection with Kingspan Ltd products only.
©Kingspan Ltd

DO NOT SCALE. IF IN DOUBT ASK

New Zealand: Kingspan Ltd
97 Montreal St
Christchurch
Tel: 03 358 7536
Fax: 03 358 7539
Freephone: 0800 121280
email: tech@kingspanpanels.co.nz
www.kingspanpanels.co.nz

Kingspan.
Insulated Panels

TOPHAT JOIN DETAIL

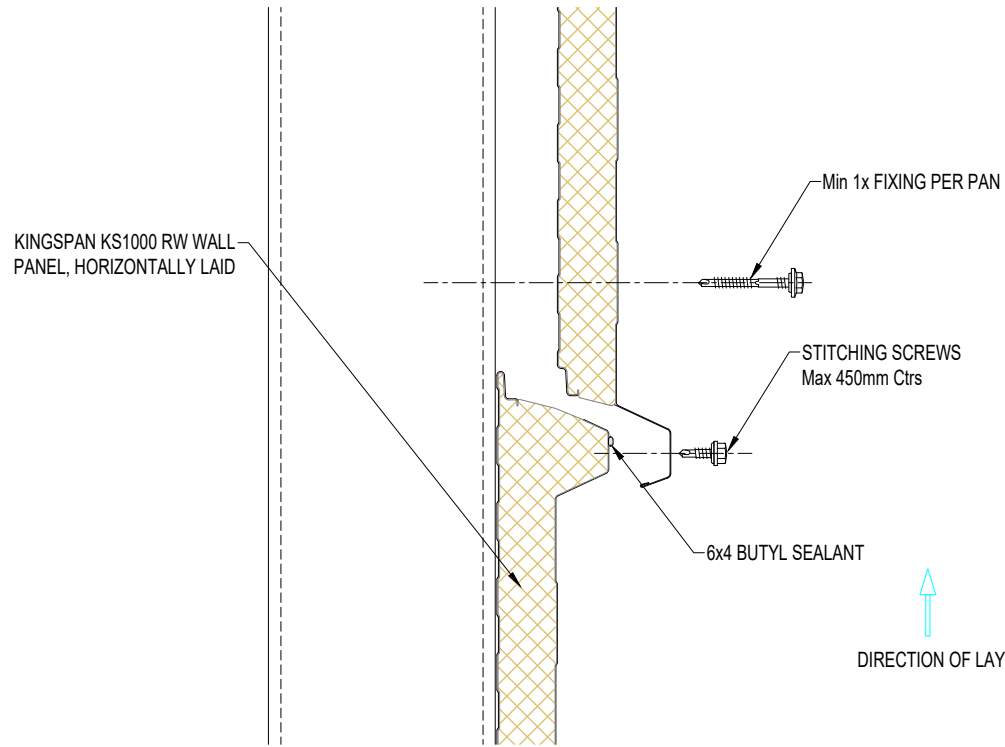
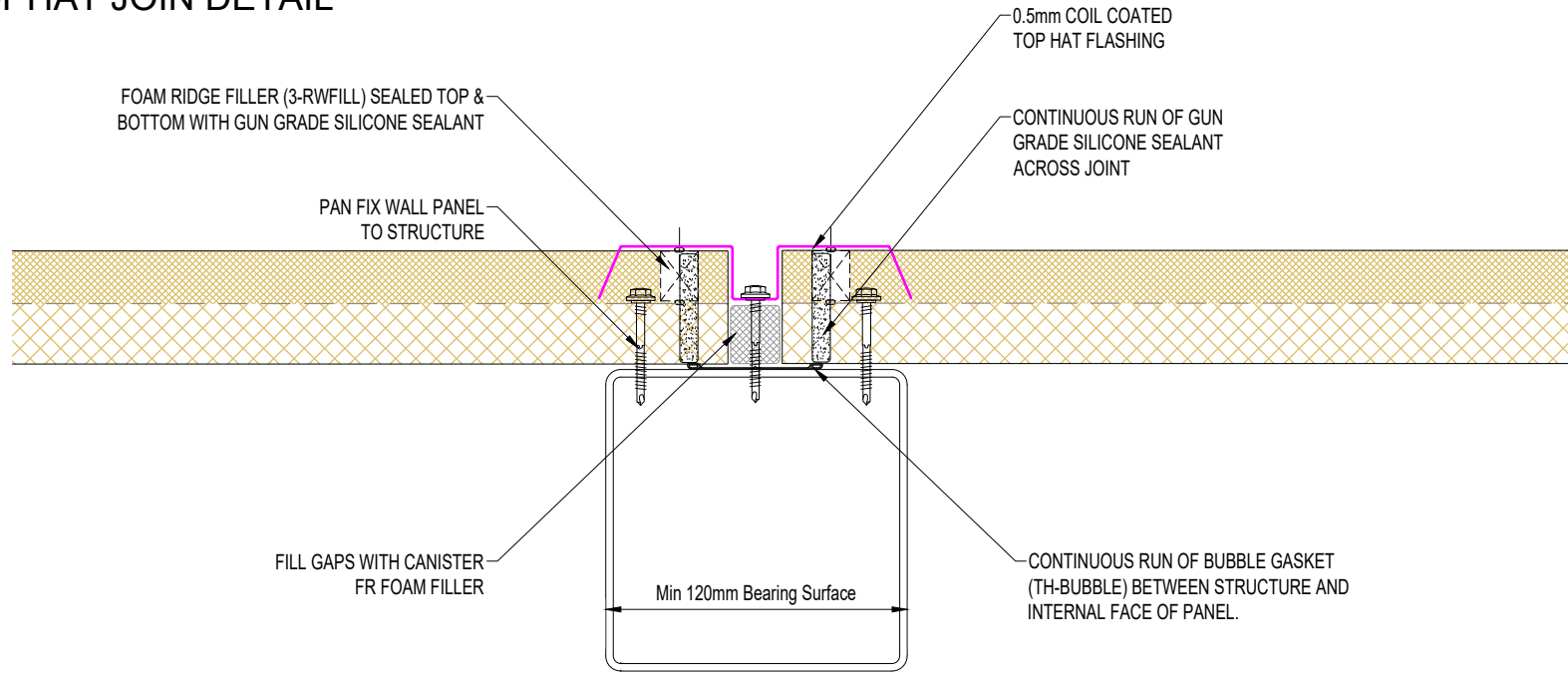

TO ENSURE CORRECT PANEL INSTALLATION, SIDE WALL STRUCTURAL SUPPORTS MUST BE CORRECTLY ALIGNED PRIOR TO INSERTION OF FIXINGS.

SYSTEM KS1000 RW_STD WALL_HORIZONTAL Q4_2020			
DESCRIPTION TOPHAT JOIN DETAIL			
APPROVED BY JS	DATE 24.09.20	REVISION -	
DRG REF: RW_HS_08	SCALE 1:5	SHEET 1 of 1	PAPER SIZE A4

This document remains the property of Kingspan Ltd under copyright laws. Licence is granted to use this document and its contents in connection with Kingspan Ltd products only.
©Kingspan Ltd

DO NOT SCALE. IF IN DOUBT ASK

New Zealand: Kingspan Ltd
97 Montreal St
Christchurch
Tel: 03 358 7536
Fax: 03 358 7539
Freephone: 0800 121280
email: tech@kingspanpanels.co.nz
www.kingspanpanels.co.nz

COVER CAP DETAIL

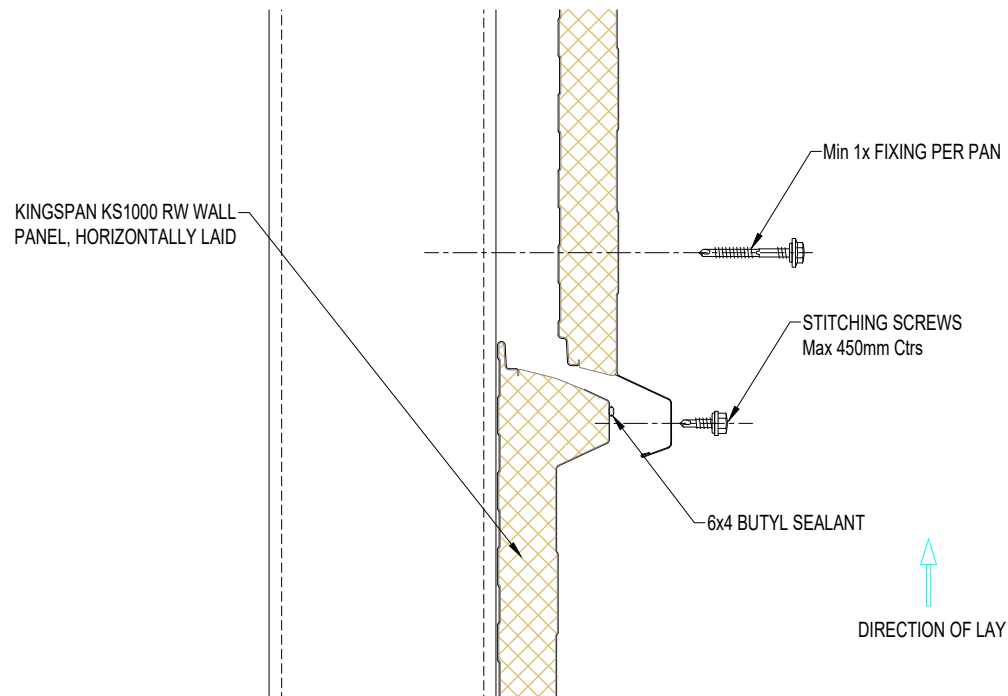
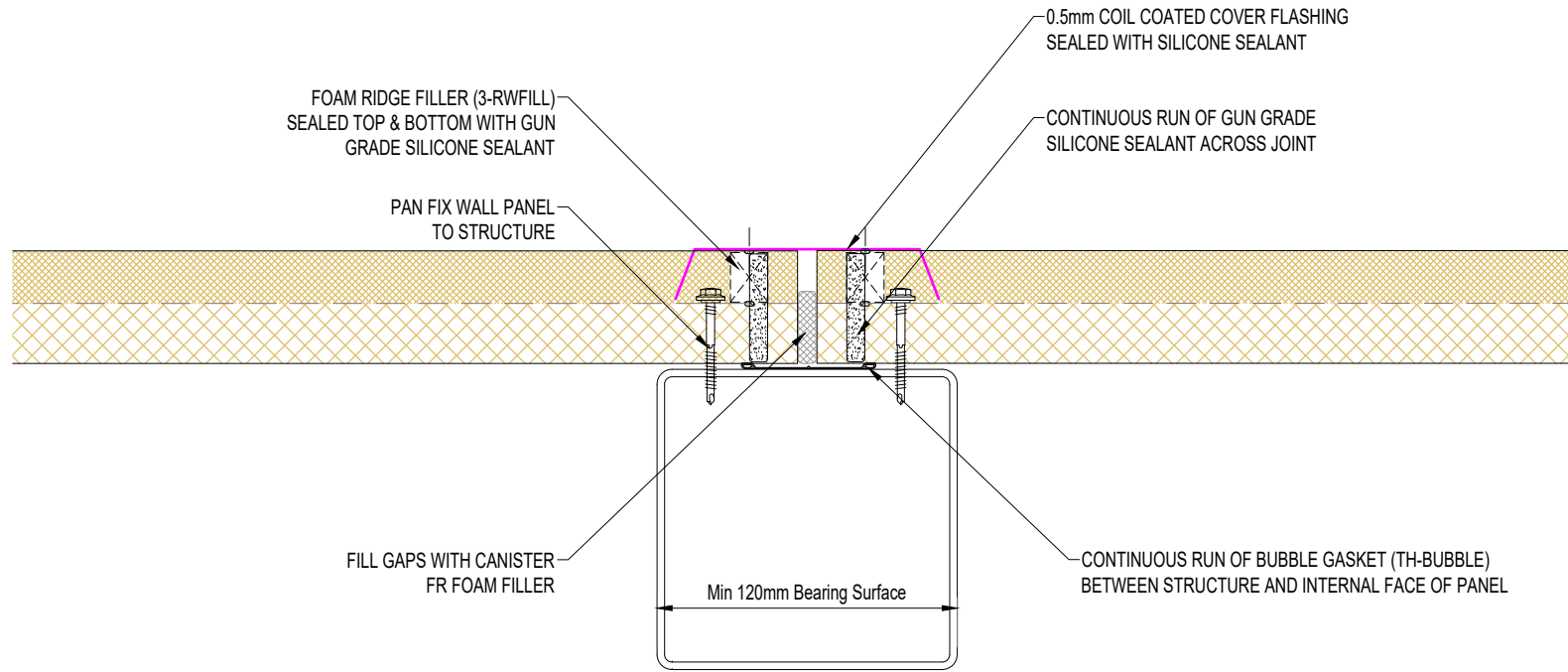

TO ENSURE CORRECT PANEL INSTALLATION, SIDE WALL STRUCTURAL SUPPORTS MUST BE CORRECTLY ALIGNED PRIOR TO INSERTION OF FIXINGS.

SYSTEM KS1000 RW_STD WALL_HORIZONTAL Q4_2020			
DESCRIPTION COVER CAP DETAIL			
APPROVED BY JS	DATE 24.09.20	REVISION -	
DRG REF: RW_HS_09	SCALE 1:5	SHEET 1 of 1	PAPER SIZE A4
This document remains the property of Kingspan Ltd under copyright laws. Licence is granted to use this document and its contents in connection with Kingspan Ltd products only. ©Kingspan Ltd			

DO NOT SCALE. IF IN DOUBT ASK

New Zealand: Kingspan Ltd
 97 Montreal St
 Christchurch
 Tel: 03 358 7536
 Fax: 03 358 7539
 Freephone: 0800 121280
 email: tech@kingspanpanels.co.nz
 www.kingspanpanels.co.nz

RW HORIZONTAL TO VERTICAL BREAK DETAIL

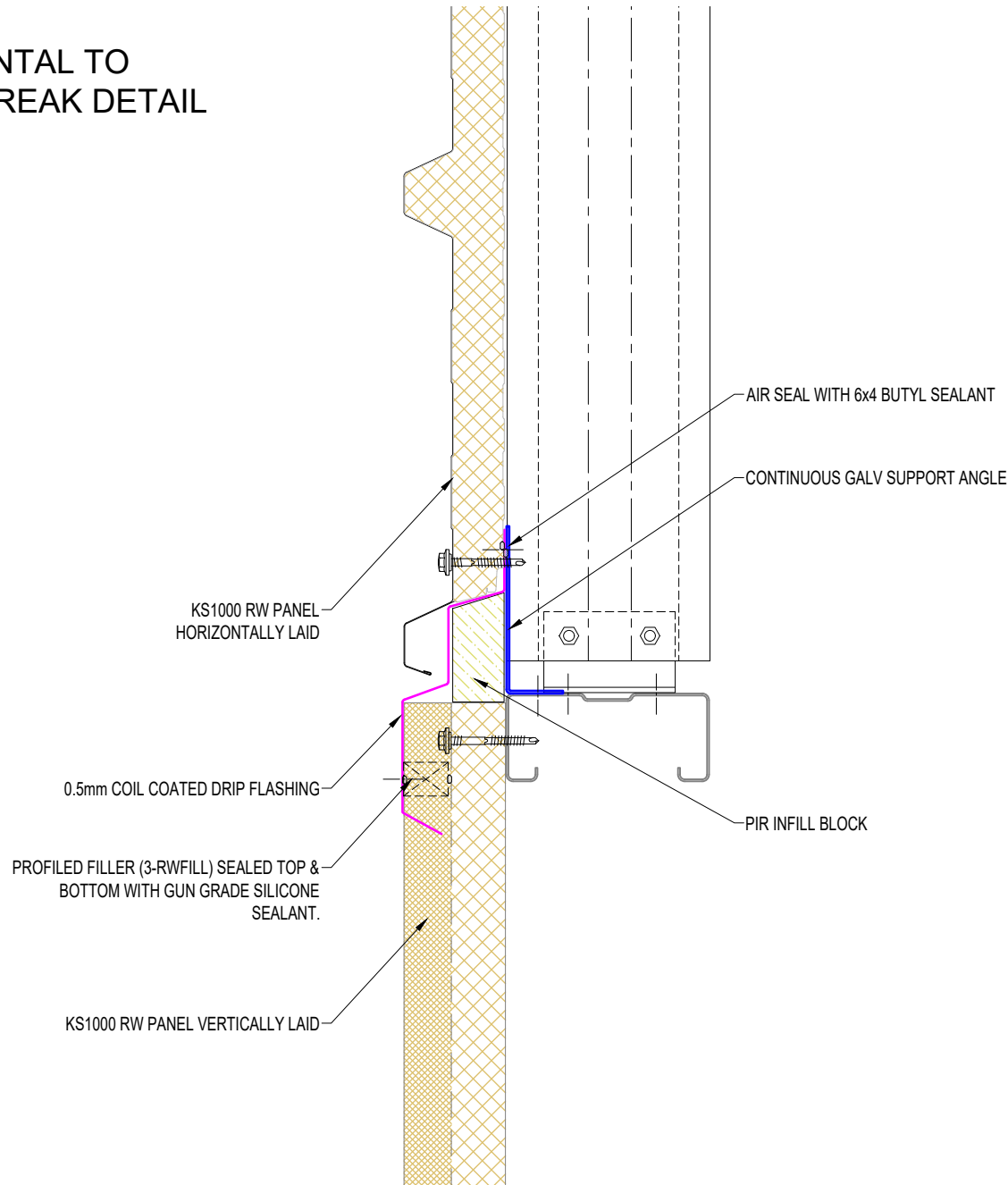

SYSTEM KS1000 RW_STD WALL_HORIZONTAL Q4_2020			
DESCRIPTION RW HORIZONTAL TO VERTICAL BREAK DETAIL			
APPROVED BY JS	DATE 24.09.20	REVISION -	
DRG REF: RW_HS_10	SCALE 1:5	SHEET 1 of 1	PAPER SIZE A4

This document remains the property of Kingspan Ltd under copyright laws. Licence is granted to use this document and its contents in connection with Kingspan Ltd products only.
©Kingspan Ltd

DO NOT SCALE. IF IN DOUBT ASK

New Zealand: Kingspan Ltd
97 Montreal St
Christchurch
Tel: 03 358 7536
Fax: 03 358 7539
Freephone: 0800 121280
email: tech@kingspanpanels.co.nz
www.kingspanpanels.co.nz



HORIZONTAL WINDOW DETAIL

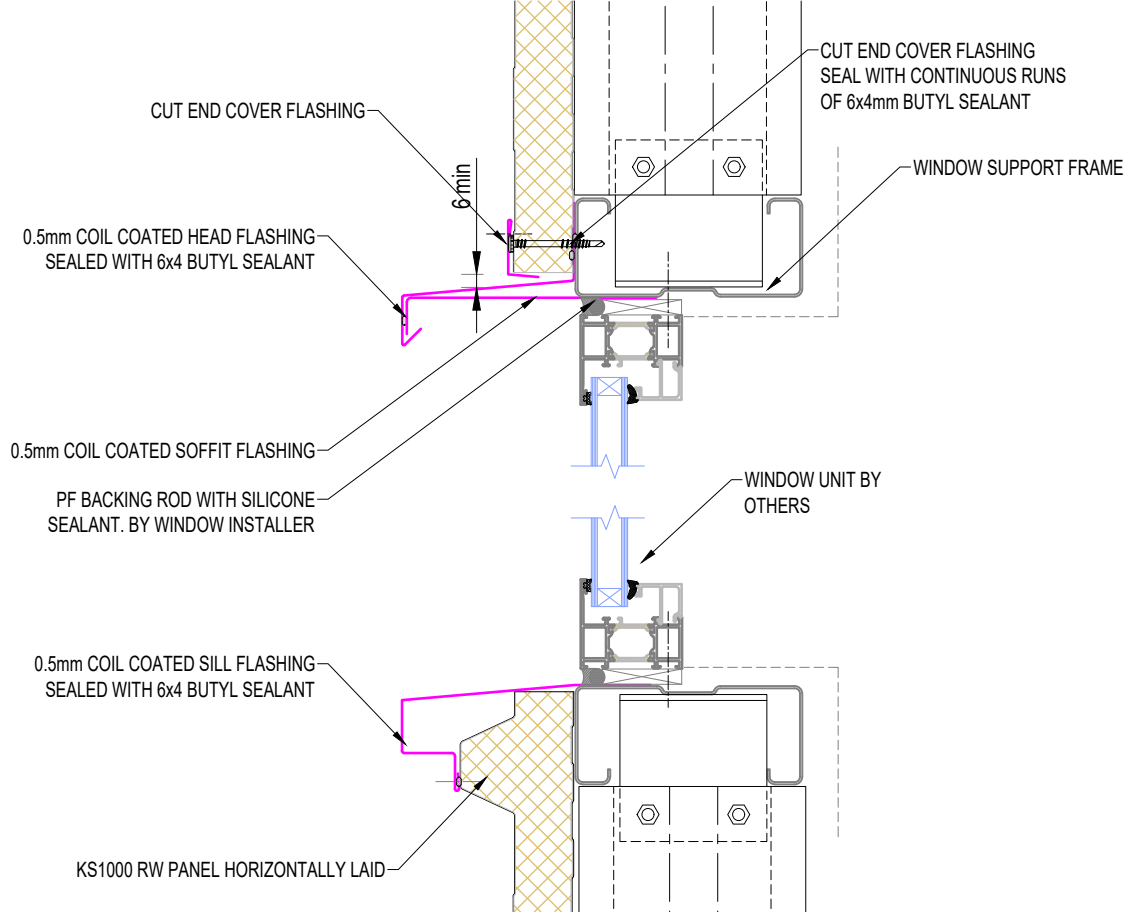
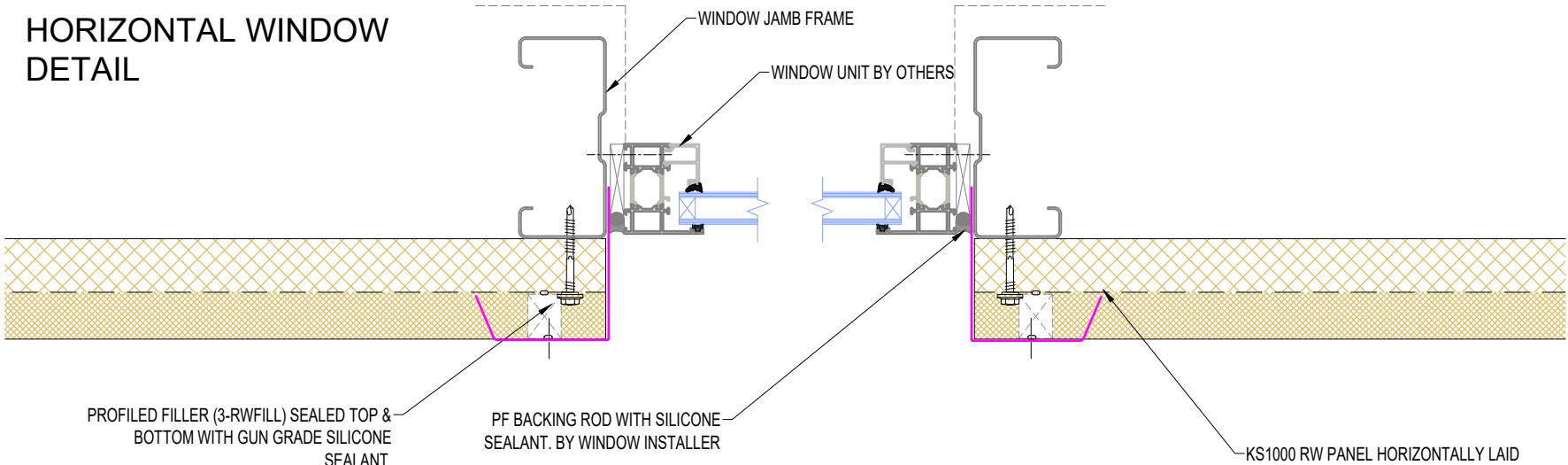

SYSTEM KS1000 RW_STD WALL_HORIZONTAL Q4_2020			
DESCRIPTION HORIZONTAL WINDOW DETAIL			
APPROVED BY JS	DATE 24.09.20	REVISION -	
DRG REF: RW_HS_11	SCALE 1:5	SHEET 1 of 1	PAPER SIZE A4

This document remains the property of Kingspan Ltd under copyright laws. Licence is granted to use this document and its contents in connection with Kingspan Ltd products only.
©Kingspan Ltd

DO NOT SCALE. IF IN DOUBT ASK

New Zealand: Kingspan Ltd
97 Montreal St
Christchurch
Tel: 03 358 7536
Fax: 03 358 7539
Freephone: 0800 121280
email: tech@kingspanpanels.co.nz
www.kingspanpanels.co.nz



PERSONNEL DOOR DETAIL

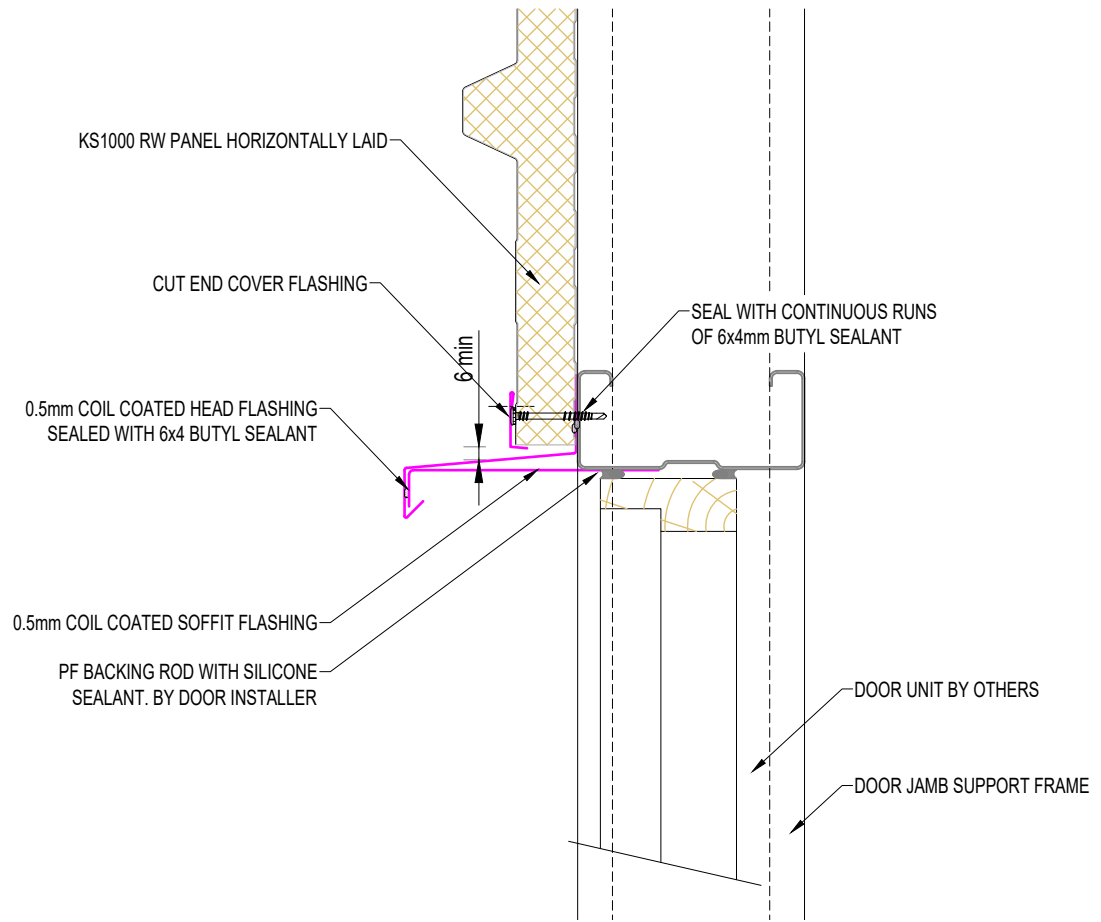
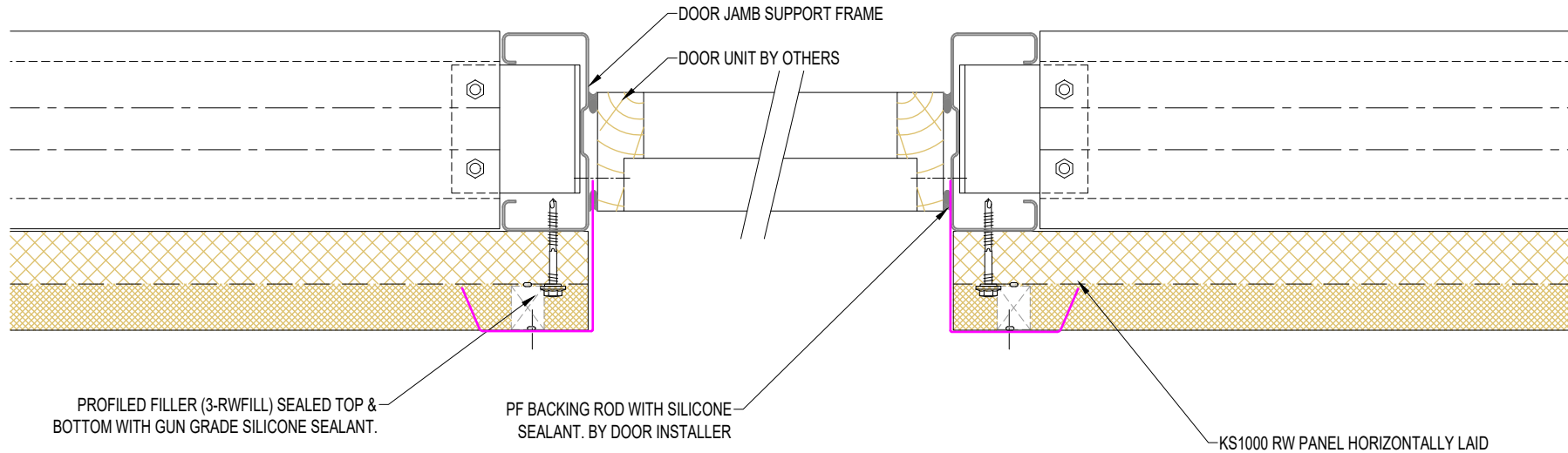

SYSTEM KS1000 RW_STD WALL_HORIZONTAL Q4_2020			
DESCRIPTION PERSONNEL DOOR DETAIL			
APPROVED BY JS	DATE 24.09.20	REVISION -	
DRG REF: RW_HS_12	SCALE 1:5	SHEET 1 of 1	PAPER SIZE A4

This document remains the property of Kingspan Ltd under copyright laws. Licence is granted to use this document and its contents in connection with Kingspan Ltd products only.
©Kingspan Ltd

DO NOT SCALE. IF IN DOUBT ASK

New Zealand: Kingspan Ltd
97 Montreal St
Christchurch
Tel: 03 358 7536
Fax: 03 358 7539
Freephone: 0800 121280
email: tech@kingspanpanels.co.nz
www.kingspanpanels.co.nz

OVERHEAD DOOR DETAIL

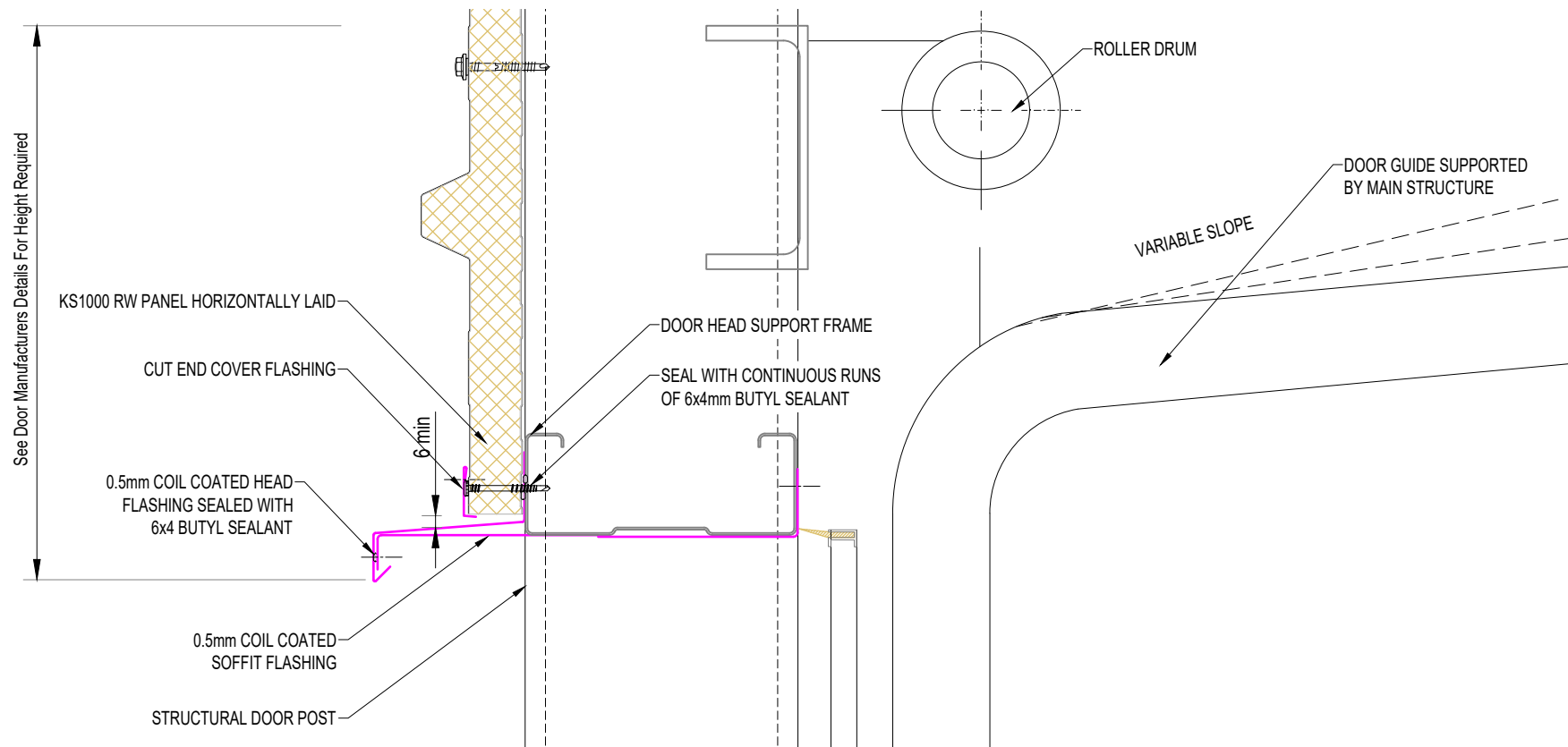
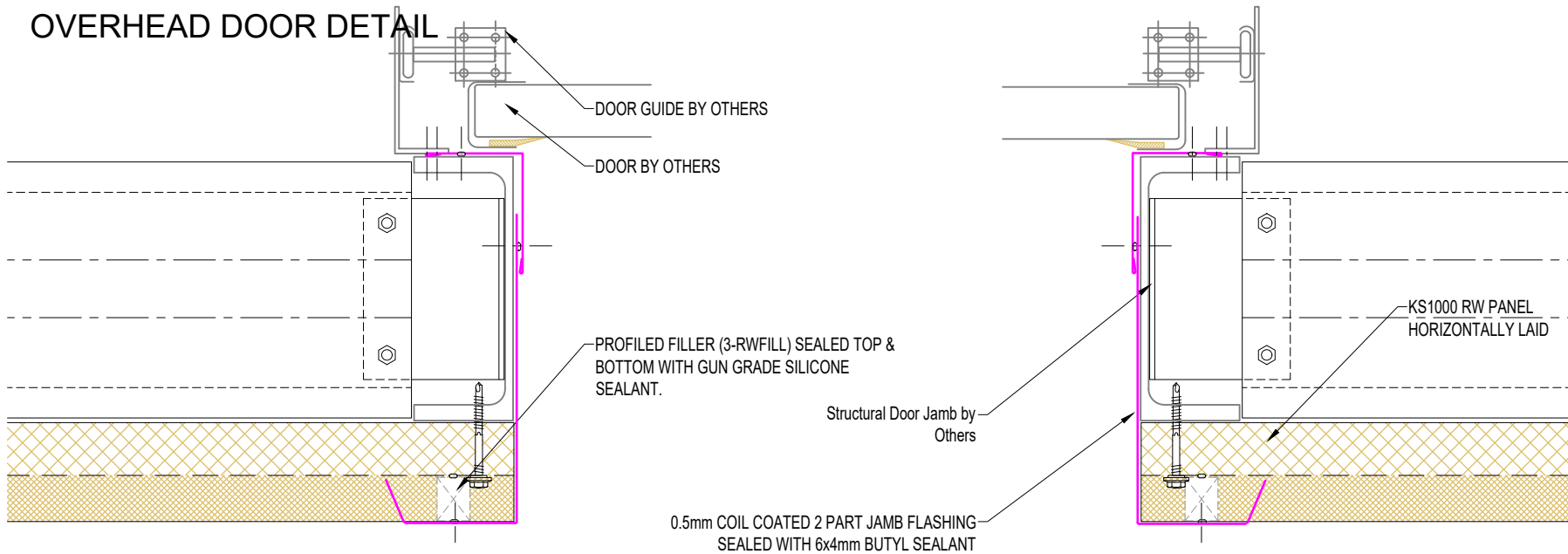

SYSTEM KS1000 RW_STD WALL_HORIZONTAL Q4_2020			
DESCRIPTION OVERHEAD DOOR DETAIL			
APPROVED BY JS	DATE 24.09.20	REVISION -	
DRG REF: RW_HS_13	SCALE 1:5	SHEET 1 of 1	PAPER SIZE A4
This document remains the property of Kingspan Ltd under copyright laws. Licence is granted to use this document and its contents in connection with Kingspan Ltd products only. ©Kingspan Ltd			
DO NOT SCALE. IF IN DOUBT ASK			
New Zealand: Kingspan Ltd 97 Montreal St Christchurch Tel: 03 358 7536 Fax: 03 358 7539 Freephone: 0800 121280 email: tech@kingspanpanels.co.nz www.kingspanpanels.co.nz			

LOUVRE DETAIL

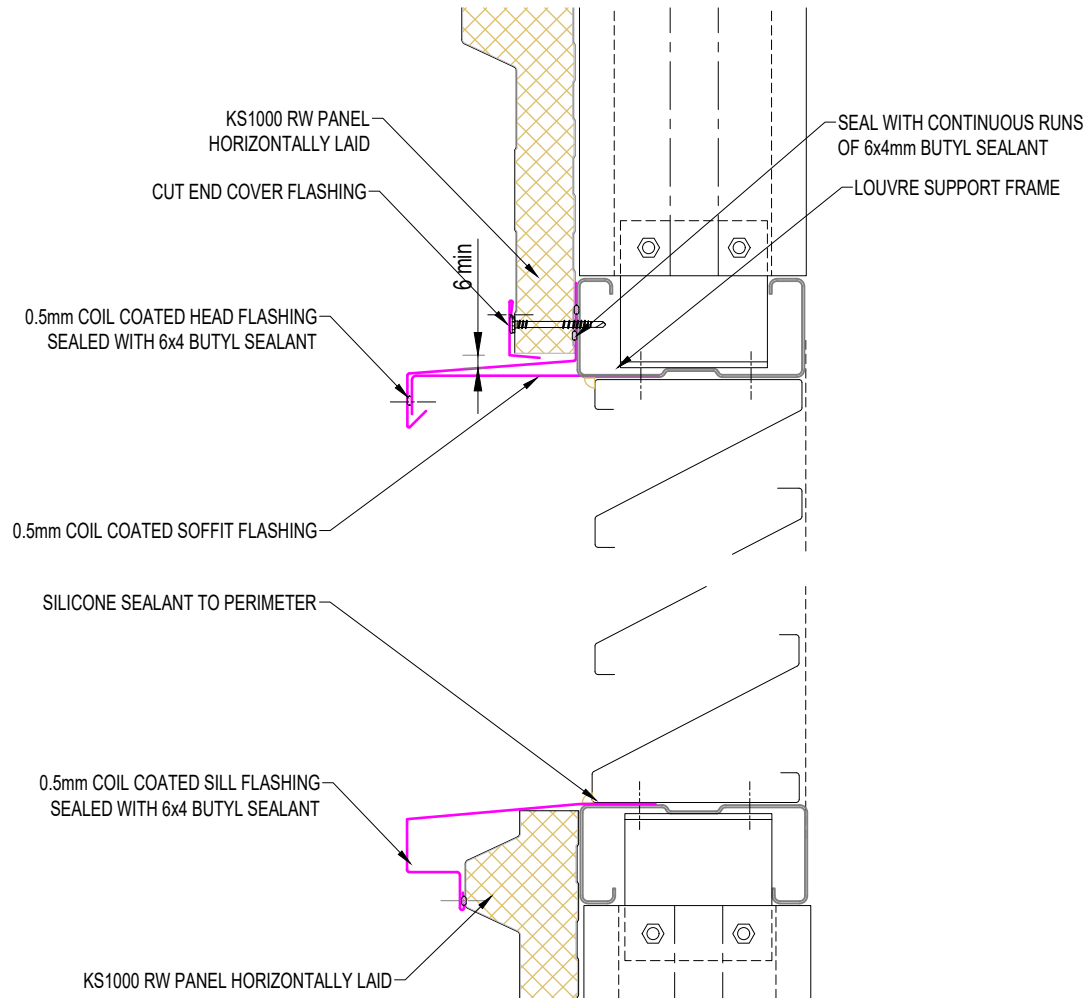
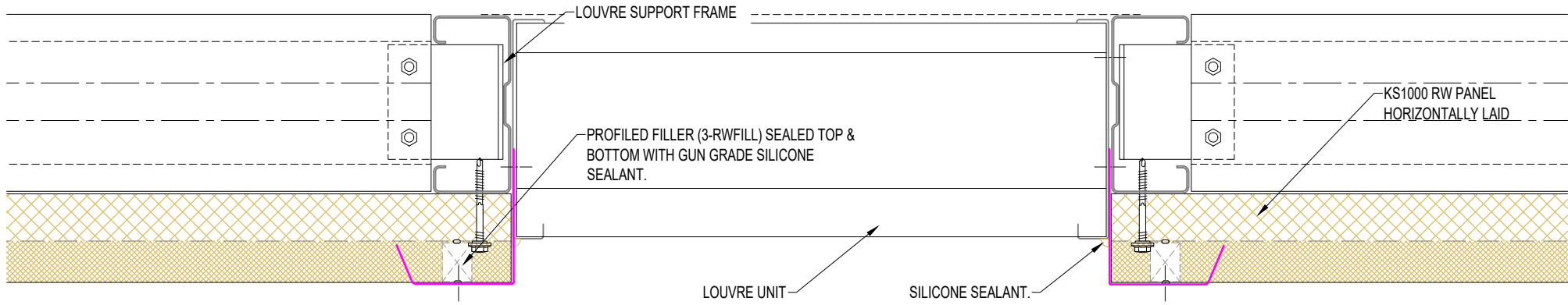

SYSTEM KS1000 RW_STD WALL_HORIZONTAL Q4_2020			
DESCRIPTION LOUVRE DETAIL			
APPROVED BY JS	DATE 24.09.20	REVISION -	
DRG REF: RW_HS_14	SCALE 1:5	SHEET 1 of 1	PAPER SIZE A4

This document remains the property of Kingspan Ltd under copyright laws. Licence is granted to use this document and its contents in connection with Kingspan Ltd products only.
©Kingspan Ltd

DO NOT SCALE. IF IN DOUBT ASK

New Zealand: Kingspan Ltd
97 Montreal St
Christchurch
Tel: 03 358 7536
Fax: 03 358 7539
Freephone: 0800 121280
email: tech@kingspanpanels.co.nz
www.kingspanpanels.co.nz

PIPE PENETRATION DETAIL

STANDARD TEMPERATURE

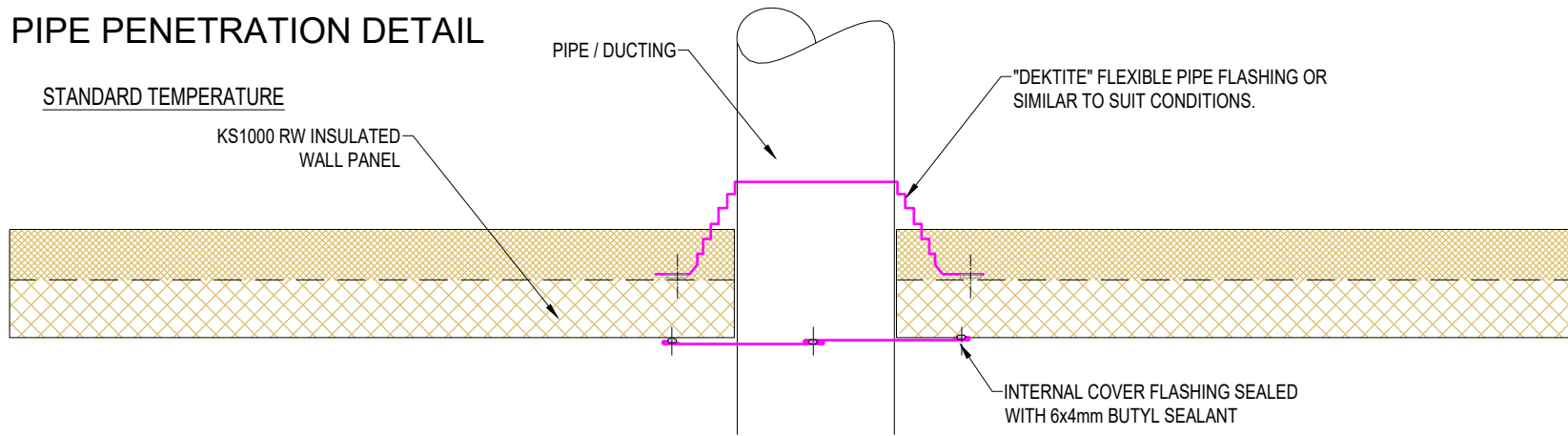

NOTE: MAXIMUM CIRCULAR HOLE SIZE TO BE 300mm. PENETRATIONS GREATER WILL REQUIRE ADDITIONAL SUPPORTING STEEL.

ALTERNATIVE STANDARD TEMPERATURE

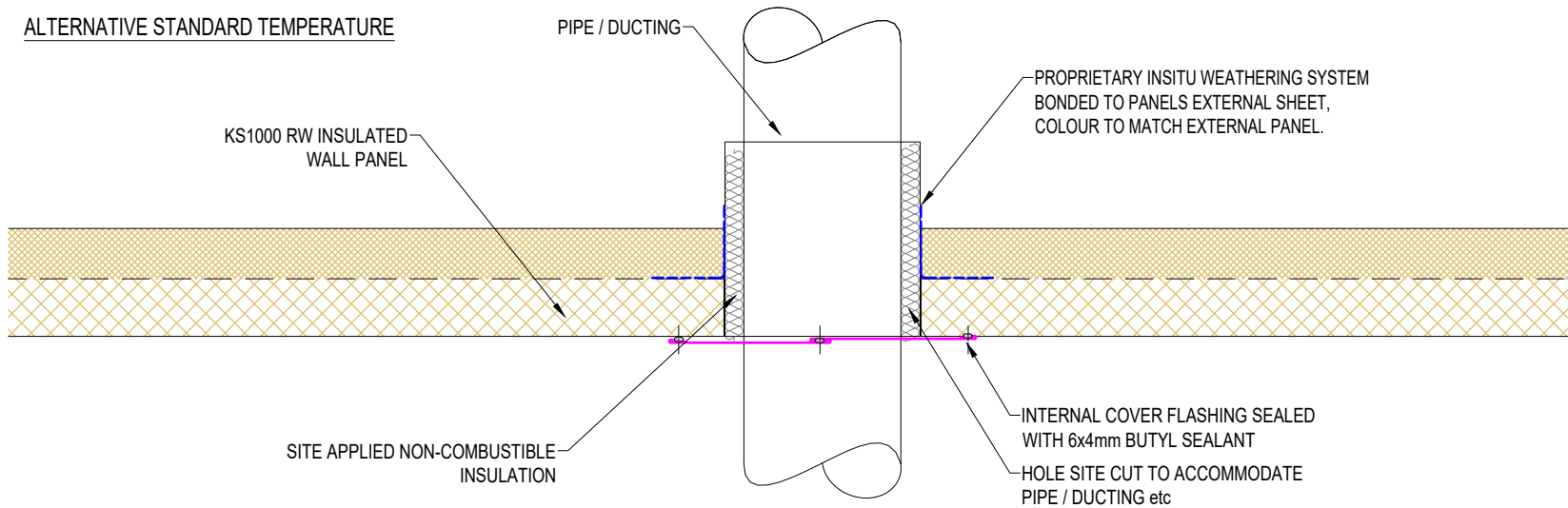

HIGH TEMPERATURE

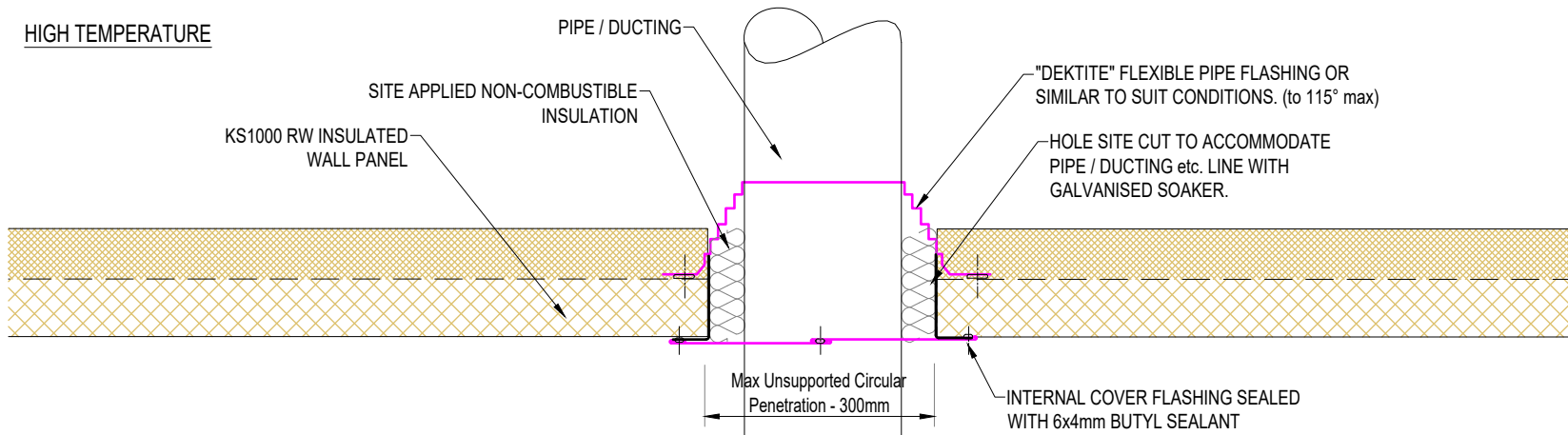

SYSTEM KS1000 RW_STD WALL_HORIZONTAL Q4_2020			
DESCRIPTION PIPE PENETRATION DETAIL			
APPROVED BY JS	DATE 24.09.20	REVISION -	
DRG REF: RW_HS_15	SCALE 1:5	SHEET 1 of 1	PAPER SIZE A4
This document remains the property of Kingspan Ltd under copyright laws. Licence is granted to use this document and its contents in connection with Kingspan Ltd products only. ©Kingspan Ltd			

DO NOT SCALE. IF IN DOUBT ASK

New Zealand: Kingspan Ltd
97 Montreal St
Christchurch
Tel: 03 358 7536
Fax: 03 358 7539
Freephone: 0800 121280
email: tech@kingspanpanels.co.nz
www.kingspanpanels.co.nz



EAVES GUTTER DETAIL

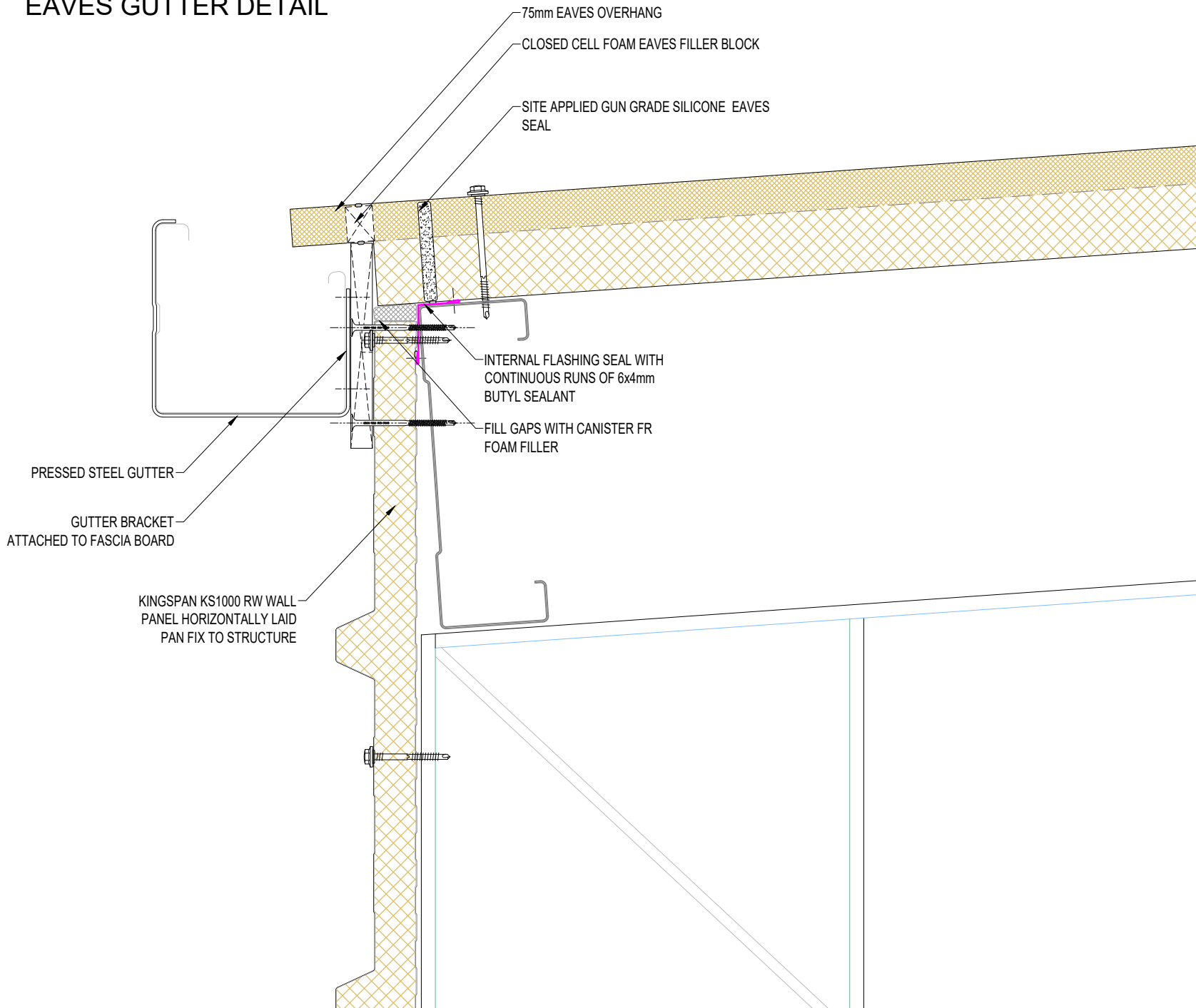

SYSTEM KS1000 RW_STD WALL_HORIZONTAL Q4_2020			
DESCRIPTION EAVES GUTTER DETAIL			
APPROVED BY JS	DATE 24.09.20	REVISION -	
DRG REF: RW_HS_16	SCALE 1:5	SHEET 1 of 1	PAPER SIZE A4

This document remains the property of Kingspan Ltd under copyright laws. Licence is granted to use this document and its contents in connection with Kingspan Ltd products only.
©Kingspan Ltd

DO NOT SCALE. IF IN DOUBT ASK

New Zealand: Kingspan Ltd
97 Montreal St
Christchurch
Tel: 03 358 7536
Fax: 03 358 7539
Freephone: 0800 121280
email: tech@kingspanpanels.co.nz
www.kingspanpanels.co.nz



KS1100 CS GUTTER, KS1000 RW ROOF & HORIZONTAL PARAPET WALL

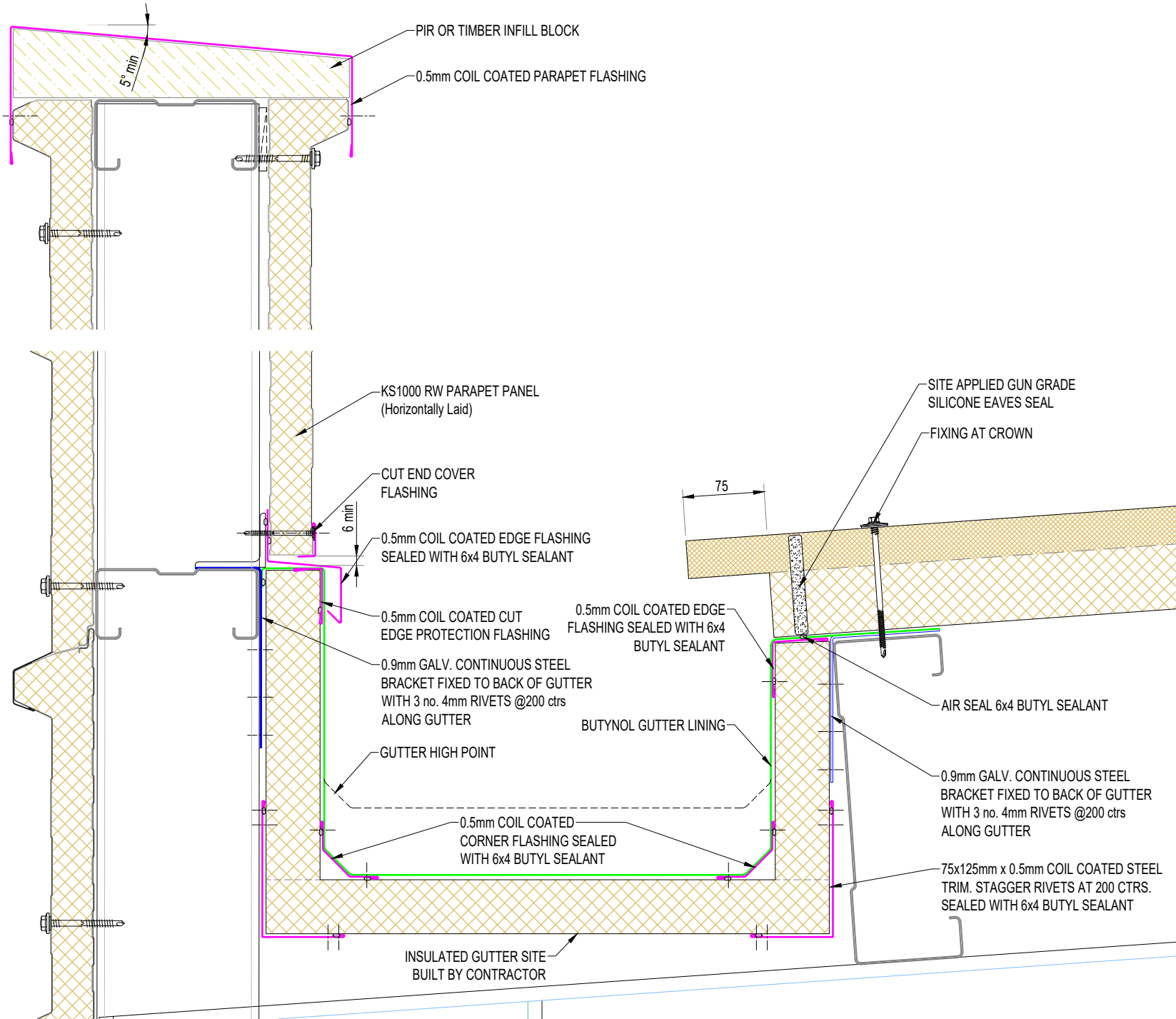

SYSTEM KS1000 RW_STD WALL_HORIZONTAL Q4_2020			
DESCRIPTION KS1100 CS GUTTER, KS1000 RW ROOF & HORIZONTAL PARAPET WALL			
APPROVED BY JS	DATE 24.09.20	REVISION -	
DRG REF: RW_HS_17	SCALE 1:5	SHEET 1 of 1	PAPER SIZE A4

This document remains the property of Kingspan Ltd under copyright laws. Licence is granted to use this document and its contents in connection with Kingspan Ltd products only.
©Kingspan Ltd

DO NOT SCALE. IF IN DOUBT ASK

New Zealand: Kingspan Ltd
97 Montreal St
Christchurch
Tel: 03 358 7536
Fax: 03 358 7539
Freephone: 0800 121280
email: tech@kingspanpanels.co.nz
www.kingspanpanels.co.nz