

OHL – Outside Horizontal Louvers

Model: OHL-C-34

34mm horizontal curved profile louvers in a channel surround.

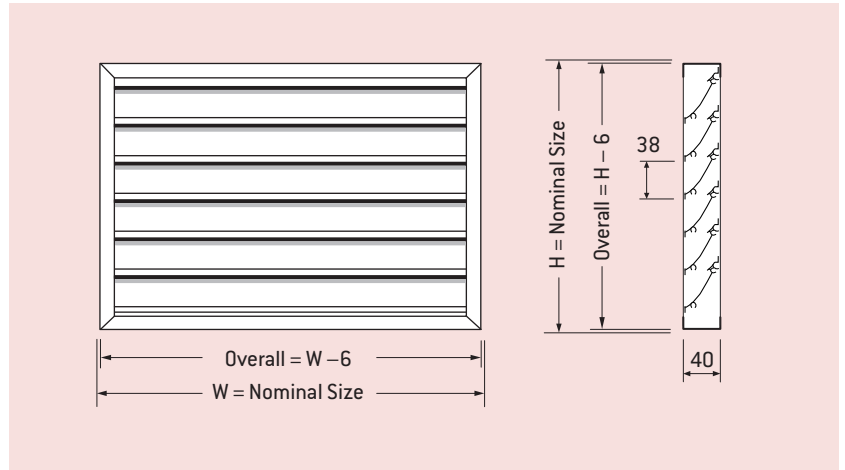

Model: OHL-F-34

34mm horizontal curved profile louvers in a flanged surround.

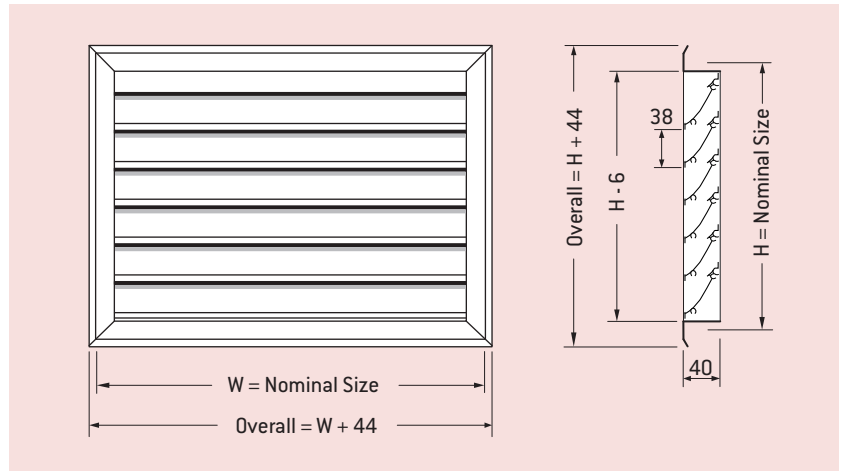

Guide Product Weights				
Approximate Weight in Kg.				
Size	OHL-C-34	OHL-F-34	OHL-C-45	OHL-F-45
300 x 300	2	2	1	1
500 x 500	4	4	3	3
900 x 900	12	12	9	9
1200 x 1200	20	20	15	15
1500 x 1800	35	35	26	26

Model: OHL-C-45

45mm horizontal curved profile louvers in a channel surround.

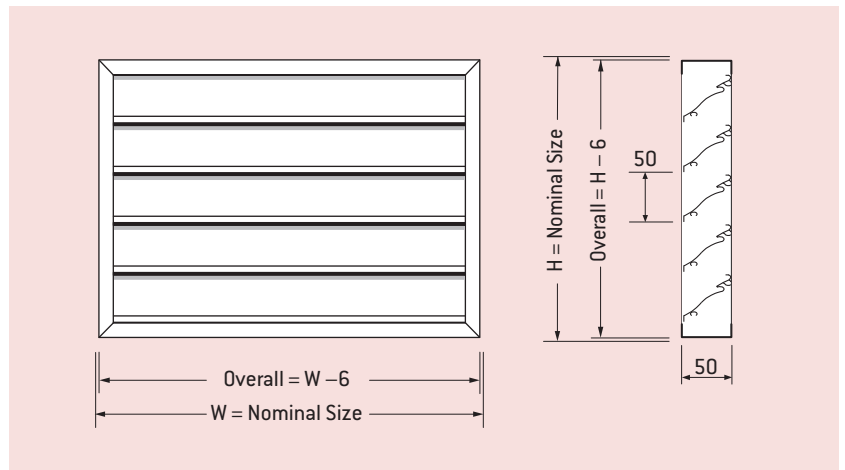

Model: OHL-F-45

45mm horizontal curved profile louvers in a flanged surround.

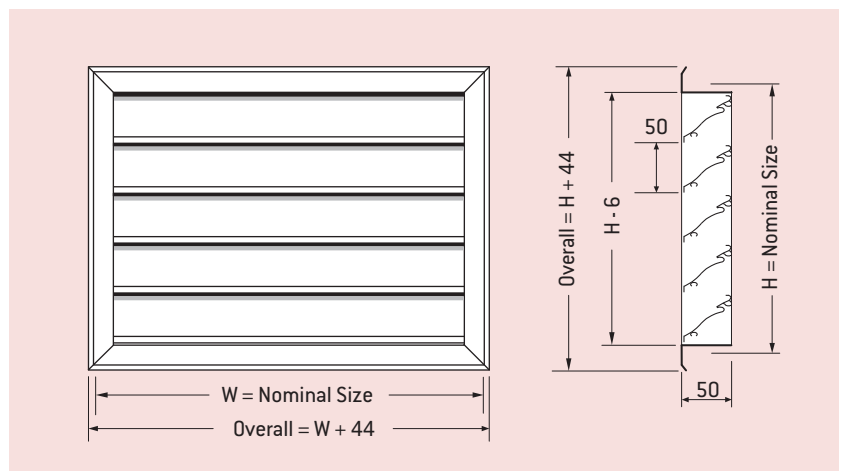

Notes

- Both OHL-F-34 and OHL-F-45 models are available with the removable core system.
- A 50mm Flange option is available on OHL-F-45.

Models: OHL-C-34 and OHL-F-34

		Effective pressure area (sq. metres)												
Width "W", mm.		300	350	400	450	500	600	750	900	1050	1200	1350	1500	
Height "H", mm.					0.03				0.07			0.10		
300		0.02	0.03	0.03	0.03	0.04	0.04	0.06	0.07	0.08	0.09	0.10	0.11	0.12
400		0.03	0.04	0.04	0.05	0.05	0.06	0.08	0.09	0.11	0.13	0.14	0.16	0.15
500		0.04	0.05	0.05	0.06	0.07	0.08	0.10	0.12	0.14	0.16	0.18	0.21	0.2
600		0.05	0.06	0.07	0.07	0.08	0.10	0.13	0.15	0.18	0.20	0.23	0.25	
700		0.06	0.07	0.08	0.09	0.10	0.12	0.15	0.18	0.21	0.24	0.27	0.30	0.3
800		0.07	0.08	0.09	0.10	0.11	0.14	0.17	0.21	0.24	0.28	0.31	0.35	
900		0.08	0.09	0.10	0.12	0.13	0.16	0.20	0.24	0.27	0.31	0.35	0.39	0.4
1000		0.09	0.10	0.12	0.13	0.14	0.17	0.22	0.26	0.31	0.35	0.40	0.44	
1100		0.09	0.11	0.13	0.14	0.16	0.19	0.24	0.29	0.34	0.39	0.44	0.49	0.5
1200		0.10	0.12	0.14	0.16	0.18	0.21	0.27	0.32	0.37	0.43	0.48	0.53	
1300		0.11	0.13	0.15	0.17	0.19	0.23	0.29	0.35	0.41	0.46	0.52	0.58	
1400		0.12	0.14	0.16	0.19	0.21	0.25	0.31	0.38	0.44	0.50	0.57	0.63	
1500		0.13	0.15	0.18	0.20	0.22	0.27	0.34	0.40	0.47	0.54	0.61	0.68	
1600		0.14	0.16	0.19	0.21	0.24	0.29	0.36	0.43	0.50	0.58	0.65	0.72	
1700		0.15	0.18	0.20	0.23	0.25	0.30	0.38	0.46	0.54	0.62	0.69	0.77	
1800		0.16	0.19	0.21	0.24	0.27	0.32	0.41	0.49	0.57	0.65	0.73	0.82	

Outside Louvers

Models: OHL-C-45 and OHL-F-45

		Effective pressure area (sq. metres)												
Width "W", mm.		300	350	400	450	500	600	750	900	1050	1200	1350	1500	
Height "H", mm.										0.1				
300		0.03	0.04	0.04	0.05	0.06	0.07	0.09	0.10	0.12	0.14	0.15	0.17	0.2
400		0.05	0.06	0.06	0.07	0.08	0.10	0.12	0.15	0.17	0.20	0.22	0.25	0.3
500		0.06	0.07	0.08	0.09	0.11	0.13	0.16	0.19	0.22	0.26	0.29	0.32	
600		0.08	0.09	0.10	0.12	0.13	0.16	0.20	0.24	0.28	0.32	0.36	0.40	0.4
700		0.09	0.11	0.12	0.14	0.15	0.19	0.23	0.28	0.33	0.38	0.42	0.47	0.5
800		0.11	0.12	0.14	0.16	0.18	0.22	0.27	0.32	0.38	0.43	0.49	0.54	
900		0.12	0.14	0.16	0.18	0.20	0.24	0.31	0.37	0.43	0.49	0.56	0.62	
1000		0.13	0.16	0.18	0.20	0.23	0.27	0.34	0.41	0.48	0.55	0.62	0.69	0.75
1100		0.15	0.17	0.20	0.23	0.25	0.30	0.38	0.46	0.54	0.61	0.69	0.77	
1200		0.16	0.19	0.22	0.25	0.28	0.33	0.42	0.50	0.59	0.67	0.76	0.84	
1300		0.18	0.21	0.24	0.27	0.30	0.36	0.45	0.55	0.64	0.73	0.82	0.92	1.0
1400		0.19	0.23	0.26	0.29	0.33	0.39	0.49	0.59	0.69	0.79	0.89	0.99	
1500		0.21	0.24	0.28	0.31	0.35	0.42	0.53	0.64	0.74	0.85	0.96	1.07	
1600		0.22	0.26	0.30	0.34	0.37	0.45	0.57	0.68	0.80	0.91	1.03	1.14	
1700		0.24	0.28	0.32	0.36	0.40	0.48	0.60	0.72	0.85	0.97	1.09	1.21	
1800		0.25	0.29	0.34	0.38	0.42	0.51	0.64	0.77	0.90	1.03	1.16	1.29	

Pressure requirement for outside louvers

Velocity, m/s **	1.0	1.5	2.0	2.5	3.0	3.5	4.0	4.5	5.0	5.5	6.0	6.5	7.0	7.5
Intake*	2	4	7	11	16	22	29	37	45	55	65	77	89	102
Exhaust*	1	3	5	8	11	15	19	24	30	37	43	51	59	68

*Total Pressure Pa (N/m²) **Velocity corresponding to Effective Pressure Area m³/s = Velocity Times Effective Pressure Area.

Example of selection for outside louvers

Select an outside louver for exhausting 0.581 m³/s with a pressure requirement of 11 Pa (N/m²).

- From pressure requirement table a velocity of 3.0 m/s is indicated as acceptable for an exhaust pressure of 11 Pa (N/m²).
- The effective pressure area corresponding to this velocity and air quantity is

$$\text{Area} = \frac{\text{m}^3/\text{s}}{\text{velocity}} = \frac{0.581}{3} = 0.19\text{m}^2$$

- For a model OHL-45 louver an effective pressure area of 0.19 m² is approximately satisfied by a 400mm wide x 1100mm high; 750mm x 600mm high, etc.