



 JURALCO

JURALCO CONTEMPORARY BALUSTRADE SYSTEM

ISSUE 7-22 v3

Juralco Contemporary Balustrade System

Juralco Aluminium Building Products Ltd designs and distributes specialist aluminium joinery systems through a national network of franchised fabricators and agents.

For more than 25 years we have been at the forefront of specialist aluminium door and window products suitable for New Zealand joinery and building methods. Our comprehensive product range includes security and insect screens, balustrades and gates, shutters and awnings, shower screens, wardrobe doors and organisers and internal doors.

The Juralco Contemporary Balustrade System combines a welded Aluminium infill frame fixed between aluminium Posts. This system is ideal for use on retaining walls and other outdoor applications where safety from falling (F4) is required by the NZ Building Code. Attaching a Handrail enables it to be used on stairs.

Features.

- Fully Welded or Rivetted Panel, Fixed Height
- Single Panel size - max 1435mm long x 1200mm high.
- Conforms to NZ Building Code and AS/NZ1170 regulations
- Only for Residential or Commercial C3 applications up to 1275mm high
- Powder Coat any colour
- Posts can be Top Mount or Face fixed
- Not suitable for fixing directly to stairs without attached Handrail
- Suitable for curved runs on Retaining Walls and Raking as well as straight or curved runs on flat Decks.

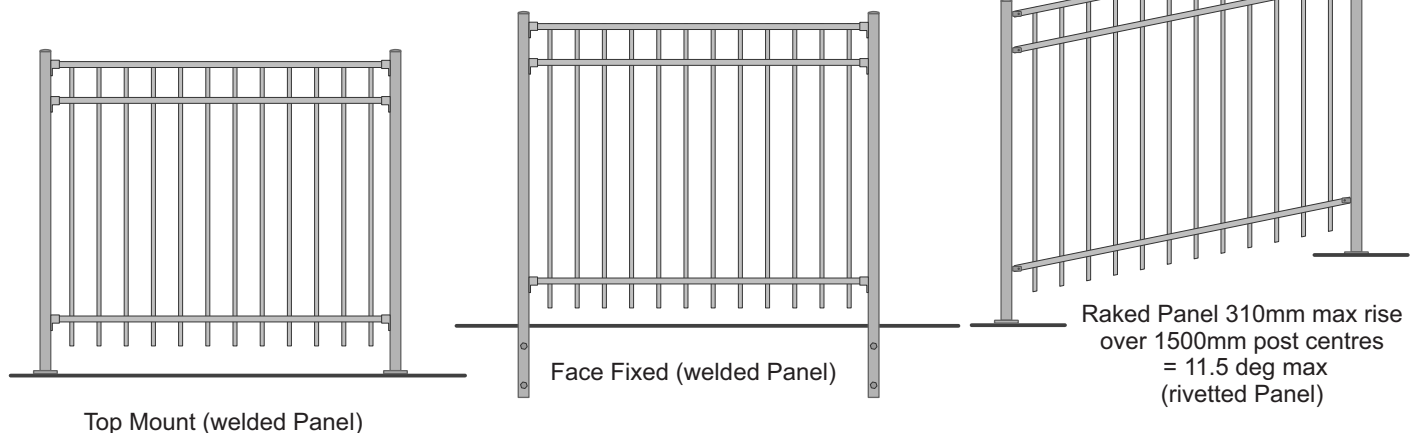

Juralco Contemporary Balustrade System

Complies With AS/NZS 1170:2002, NZ Building Code Clauses B1, B2, F2, F4 and F9

Juralco Contemporary Balustrade is for Domestic and Residential Occupancy types A, A Other and C3 and Commercial C3

Code	Type of Occupancy for part of the building or structure	Specific Uses	Wind Zone
A	Domestic and Residential activities	All areas within or serving exclusively one dwelling including stairs, landings etc, but excluding external balconies and edges of roofs. (see C3)	Suitable for use up to and Including Extra High Wind Zone
A Other, C3	Areas without obstacles for moving people and not susceptible to over crowding	Landings, external balconies, edges of roofs etc. Not suitable for fixing directly to stairs unless separate Handrail attached	

Note 1 **Juralco Balustrade Systems building code compliance documentation requires all balustrade installations are to be completed in accordance with the requirements of our authorised installer certification.**

Note 2 **This system is not designed as a 'stair' balustrade system. Do not attach directly to stair risers unless separate Handrail attached.**

masterspec partner
Section 4852JB

Index

Type	Pages	Description. Use the Bookmarks List to jump to selected pages
Specifications	4	Juralco standard specification sheet and Powder coating recommendations
Materials	5 - 8	All Extrusions and Components
Cutting	9	Shows Cutting calculations
Manufacture	10 - 11	Shows Manufacture and Assembly details
Mountings	13	Shows Top mount and Face fix mount types
Mountings	14 - 26	Shows Mounting details - For Timber (p14-19), Steel (p20-23) and Concrete (p24-26)
	27 - 29	Shows Mounting details. Older Timber structures pre NZS3604:2011 (Not suitable for C3 Commercial)
	30 - 33	Shows Mounting details for Retaining Walls
Powder Coat	34	Information on the care of Powder Coat surfaces

Juralco Contemporary Balustrade System - Specifications, Powder Coating

Juralco Aluminium Building Products Ltd (JABP)

Specifications for Juralco Contemporary Balustrade System

1. Scope

- This specification details the documents the Juralco Contemporary Balustrade System refers to in relation to the New Zealand Building Code, the manufacturer's documents, products used in the System, requirements in relation to fixing and surface finishing.

2. NZBC Compliance

- The Juralco Contemporary Balustrade System has been reviewed by Lautrec Technology Group Ltd to demonstrate compliance with the structural requirements of the New Zealand Building Code and AS/NZS 1170 : 2002 occupancy A, A Other and C3, NZS 3604 Low, Medium, High, Very High and Extra High Wind Zones
- The Structural Engineering design includes the requirements of B1 Structure, B2 Durability, F2 Hazardous material and F4 Safety from falling, all from the Building Code.
- Verification Method B1 / VM1, B2/AS1, F4 / AS1

3. Manufacturer's Documents

- The Juralco Contemporary Balustrade System manual details all extrusions and components used for the fabrication and installation/fixing of the system.
- A Producer Statement 1(Design) is available.
Copies of the above documents are available from:
Juralco Aluminium Building Products Ltd
48 Bruce McLaren Rd, Henderson, Auckland
Phone 09 478 8018 Fax 09 478 7883 Email specify@juralco.co.nz
- Any deviation from the standard fabrication or installation/fixing must be accompanied by a site specific PS1 with site specific calculations and drawings

4. Products

- Only extrusions, components and hardware supplied by or specified by JABP may be used in the Juralco Contemporary System
- Aluminium extrusions, components and hardware – unless specified are manufactured to 6060 T5 specifications
- Stainless Steel components, hardware, fixings – all components to 316 grade

5. Surface Finishing

- Juralco Aluminium Building Products Ltd is a Dulux Registered Applicator site, registration number 2101.
JABP uses only Dulux branded powder coating materials
- Unless specified otherwise, Dulux Duralloy® powder coating systems are used for properties greater than 100 metres from high tide level where AAMA 2603 performance is required
- Dulux Duratec® powder coating systems must be used for all properties greater than 10 metres and up to 100 metres from high tide level where AAMA 2604 performance is required
- Dulux Duralloy® has a 10 year film and colour integrity warranty, Dulux Duratec® has a 20 year film and colour integrity warranty

6. Installation and Fixing

- The Juralco Contemporary Balustrade System must only be installed in accordance with the Juralco Contemporary Balustrade System manual
- Any deviation from that specified in the Juralco Contemporary Balustrade manual must only be in accordance with the site specific PS1 and with site specific calculations and drawings listing the non standard details
- The Juralco Contemporary Balustrade System must only be fabricated/installed by a Juralco approved fabricator
- Upon completion of the installation the fabricator must supply the owner with a PS3 (Construction)

Important instructions for Powder Coatings near Salt Water

The standard Dulux powder coating system used by Juralco is Duralloy® and is suitable for installations greater than 100 metres from high tide level and for buildings up to 3 stories above ground. Use Duratec® for installations between 10 and 100 metres from high tide level and for prestigious residential and commercial developments. For all other applications contact Juralco for alternative systems.

Note - Powder coated prices listed in Juralco price books are for the standard Duralloy® system. If the Duratec® system is required it must be specified upon placement of the order and will incur a surcharge – Duratec® prices on application.

Important instructions for Powder Coating - Attachment to structures

An EPDM or similar material spacer must be used to separate powder coated aluminium items from all timber, concrete and steel structures. Failure to do so can lead to the chemicals in the structure affecting the powder coating layer on the aluminium.

Powder Coating Warranty

The Dulux powder coating warranty period is conditional upon being maintained in accordance with the Dulux 'Care and Maintenance Instructions'. Contact your installer for a copy (or download from Dulux) of the Care and Maintenance instructions or refer to the back page of this manual.



Juralco Contemporary Balustrade System - Extrusions

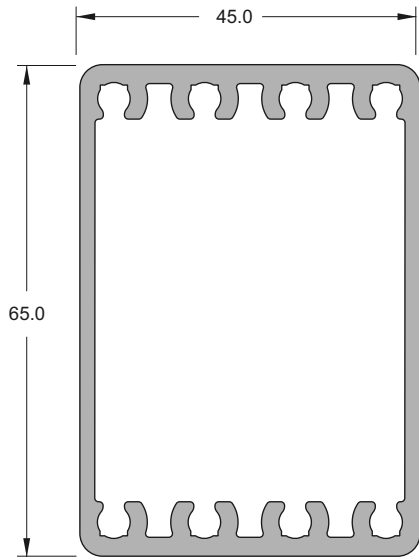

POST
Part No JGF/215/5

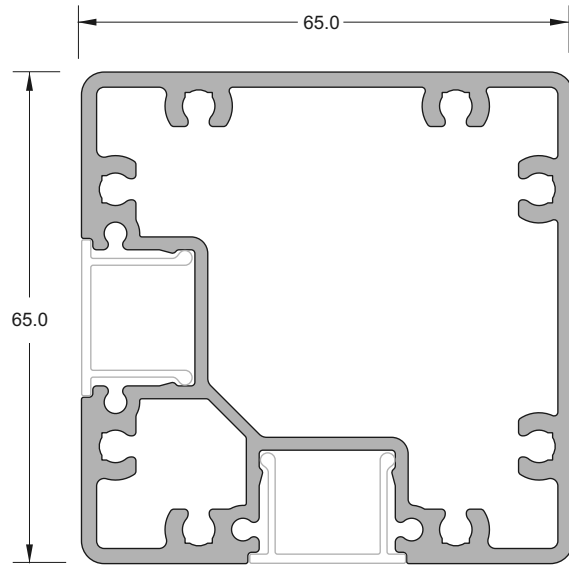

POCKETED CORNER POST
Part No JEB/213/5

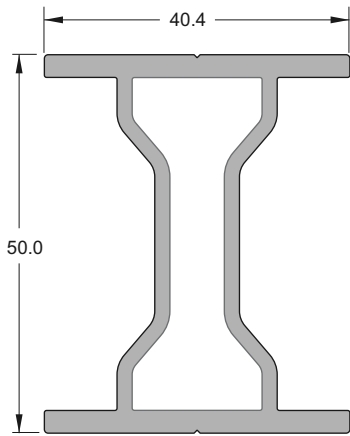

POST STIFFENER
JGF 213

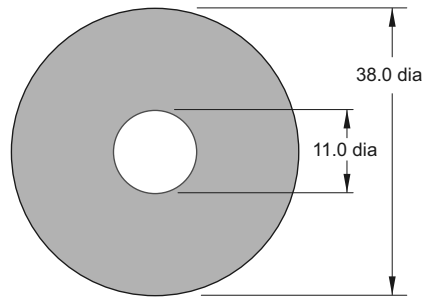

FACE FIX SPACER
Part No JVB 125/1000

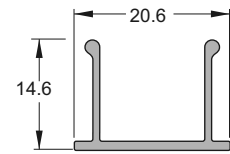

STANDARD INFILL CLIP
Part No JEB/206/5

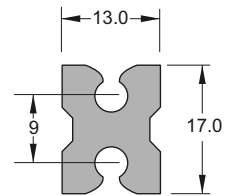

RAIL SPIGOT
Part No JEB/210/5

Panel Parts

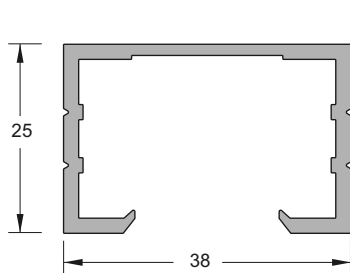

RAIL
Part No FPR

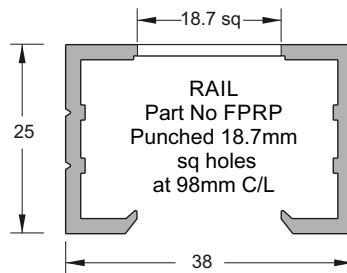

RAIL
Part No FPRP
Punched 18.7mm
sq holes
at 98mm C/L

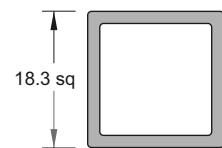

BALUSTER
Part No FPBA

Juralco Contemporary Balustrade System - Components

Base plate
Part No JEC 201

Top Mount.

Concrete or Steel only

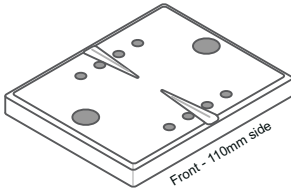

110mm x 90mm x 12mm - 2 x hole

Base plate
Part No JEC 221

Top Mount

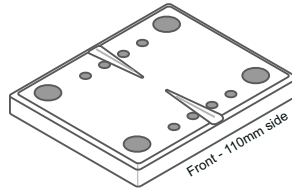

110mm x 90mm x 12mm - 4 x hole

Base plate - Corner Post
Part No JEC 222

Top Mount

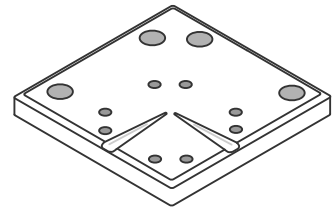

110mm x 110mm x 12mm - 4 x hole

Square Washer
Part No JVB SQWSH

Face Fix

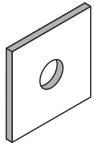

40mm sqx 3mm SS

Base plate
Part No JEC 137/65

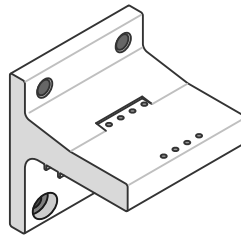

120mm wide x 135mm high - 4 x holes

Gutter Bracket Spacer
Part No JEC 139

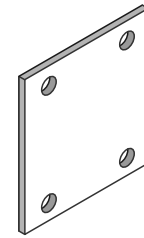

135mm x 120mm x 5mm thick

Post Bottom Cap
Part No JEC16

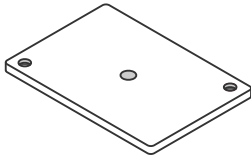

45mm x 65mm - Fits under face Fix Posts
Attach with No 6 x 12 C/S SS PK screws

Top Cap
Part No JEC 20

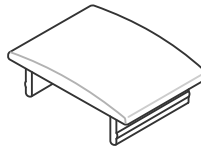

Fits over Post 65mm x 45mm

Top Cap - Corner Post
Part No JEC 27

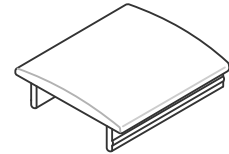

Fits over Post. 66mm x 66mm

Post Bracket
Part No FPRBKT

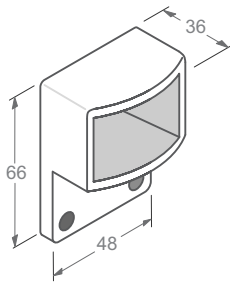

Aluminium Body

This Bracket for normal Straight runs

Post Bracket, Angled
Part No FPRBKT/A

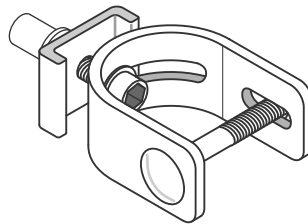

Rail connection, angle adjustable
- 0 to 40 deg, horizontal plane.
- 0 to 11 deg in vertical plane

This Bracket for Curved walls and Raked Panels

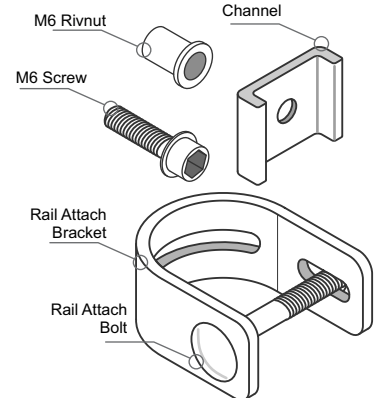

Aluminium Body /Black PC

Juralco Contemporary Balustrade System - Components

Face Fix Spacer
Part No JVB 125/30mm

Face Fix

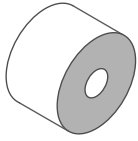

38mm dia x 30mm long.

Face Fix Spacer
Part No JVB 125/10mm

Face Fix

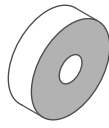

38mm dia x 10mm long.

EPDM Spacer Washer
Part No JVB 126

Face Fix



38mm dia x 3mm

Attachment Block Screw
Part No JVBSCREW/30x8

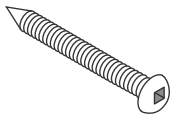

30mm SS HT PK Pan sq drive screw

Base Attach Screw
Part No JVBHTSCREW/50x10

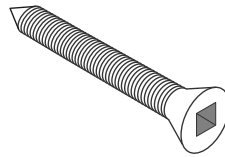

50mm SS HT PK C/S sq drive screw

Rail Attach Screw
Part No JGFSCREW/12x8



WASHER SS
Part No JVB Washer 21x11



21dia x 11 x 2mm thick

SIKA Supergrip 2hr
Part No JEC SUPERGRIP

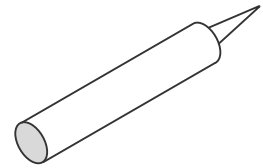

For All Coachscrews fixings

Juralco Contemporary Balustrade System

Welded Frame
Part No JGF/FP12

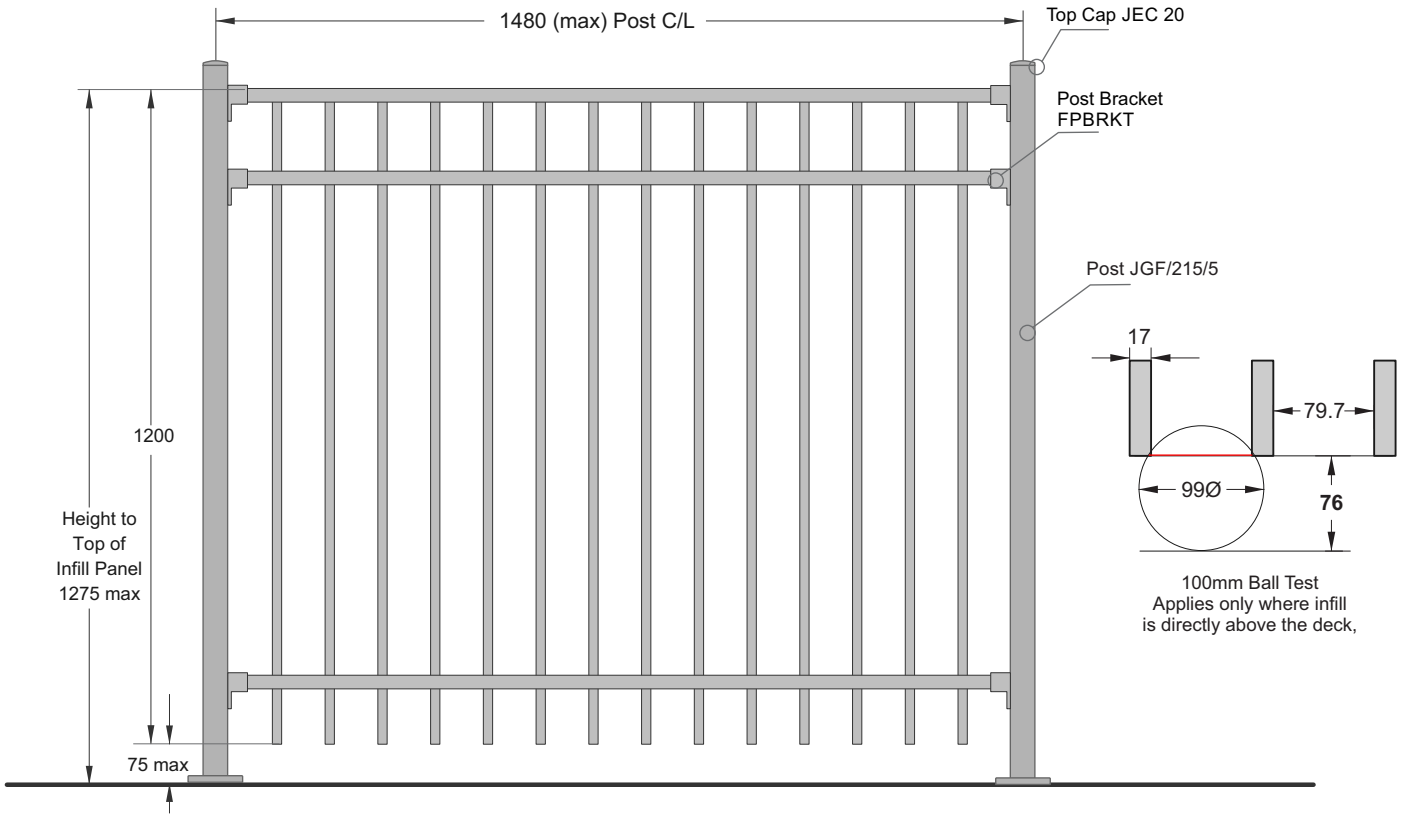

Riveted Frame
Part No JGF/FP12R

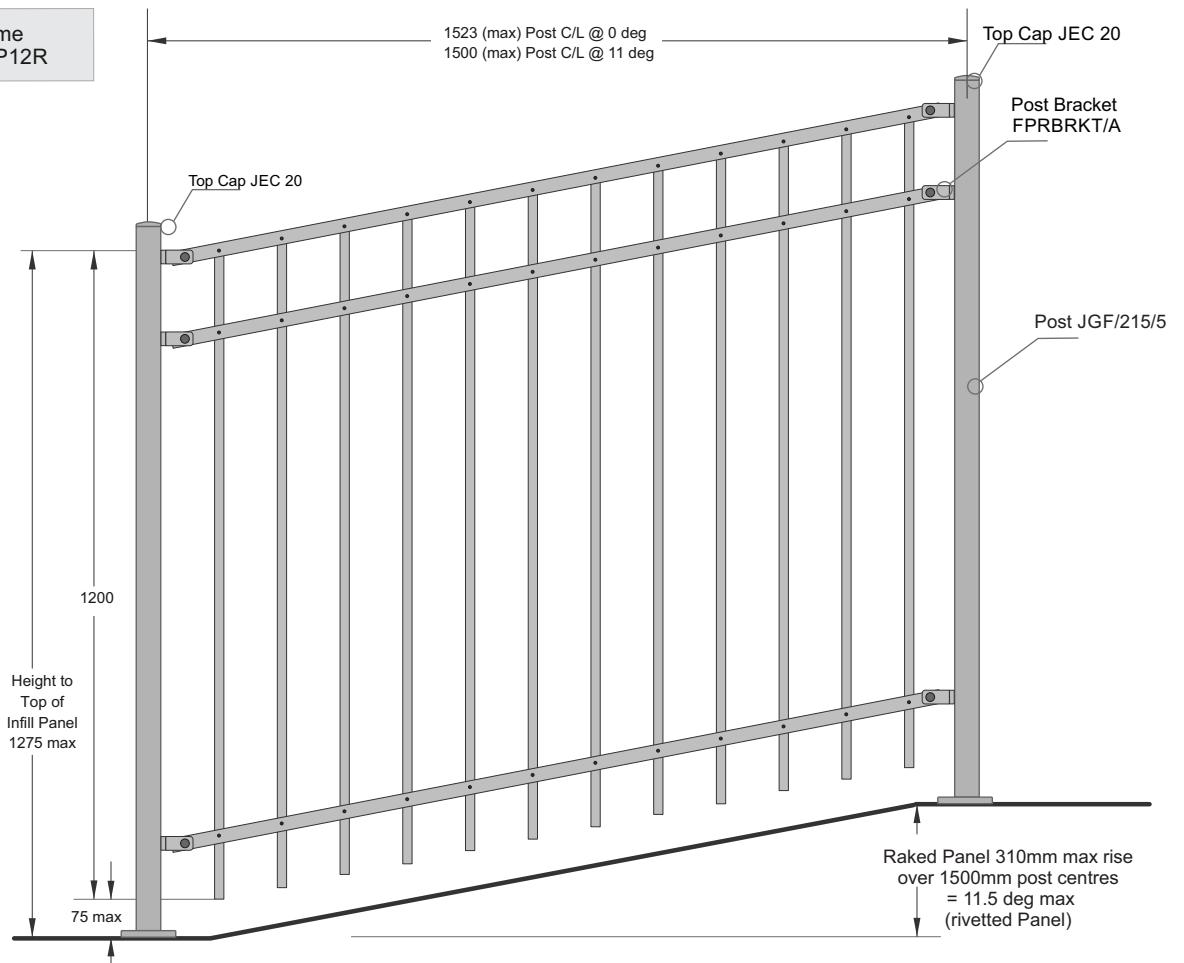

Juralco Contemporary Balustrade System

Cutting a Fully Welded Frame

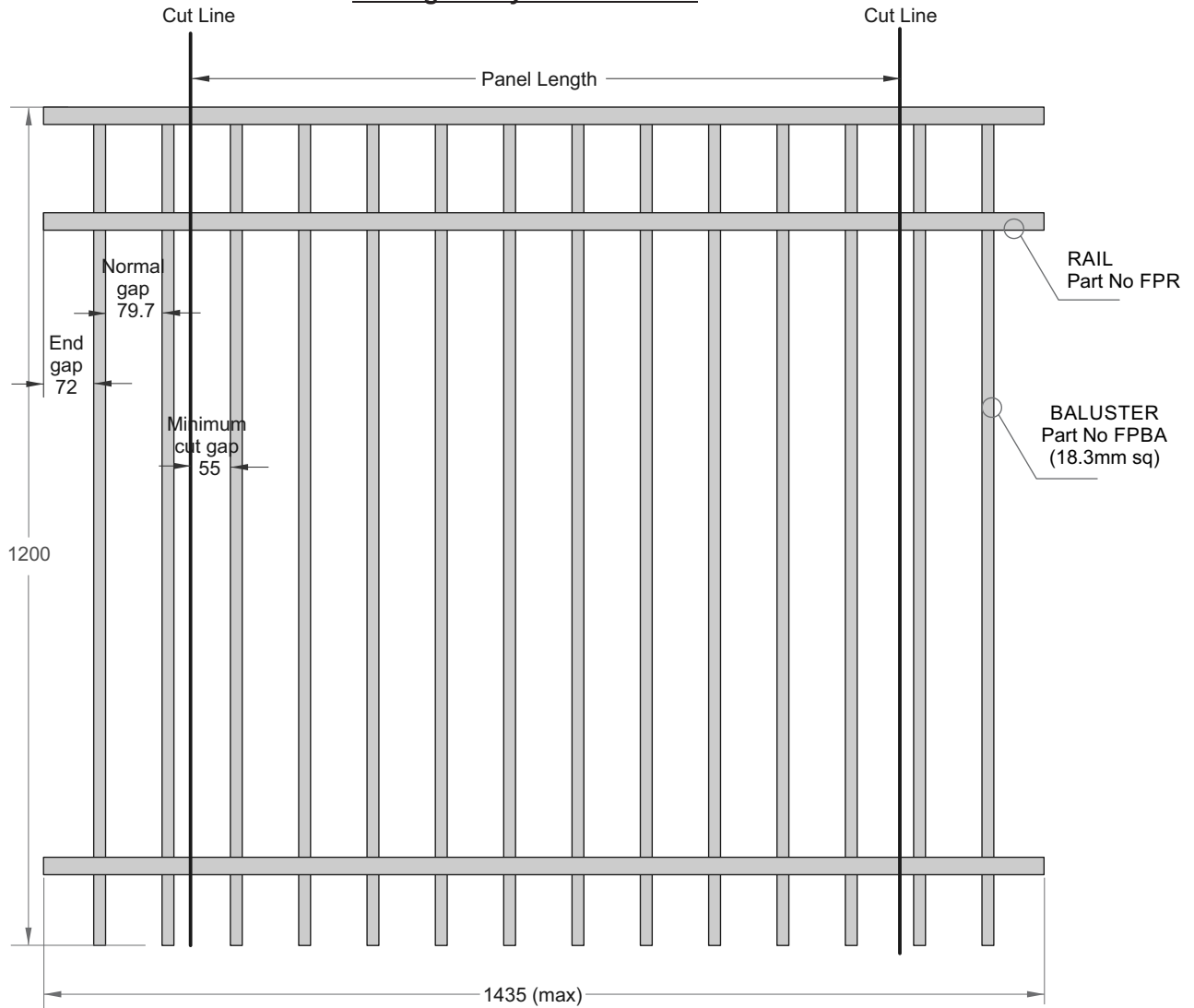

CONTEMPORARY BALUSTRADE INFILL PANEL
Part No JGF/FP12
All fully welded. Cut to required length

Cutting a Panel to a custom length has the following constraints

The table below shows allowable Post centre Lengths for a given no of Balusters

No of Balusters	14	13	12	11	10	9	8	7	6	5	4
Post Centres MAX	1480	1390	1292	1194	1096	998	901	803	705	607	509
Post Centres MIN	1446	1348	1250	1152	1054	956	859	761	663	565	467

To calculate Panel cut lengths subtract about 50mm from the post centre dimensions (= 5mm float)

This Bracket for normal Balustrades on Decks and straight Retaining walls

- 1 - Cut Spigot to 20mm long.
Drill hole 3mm dia

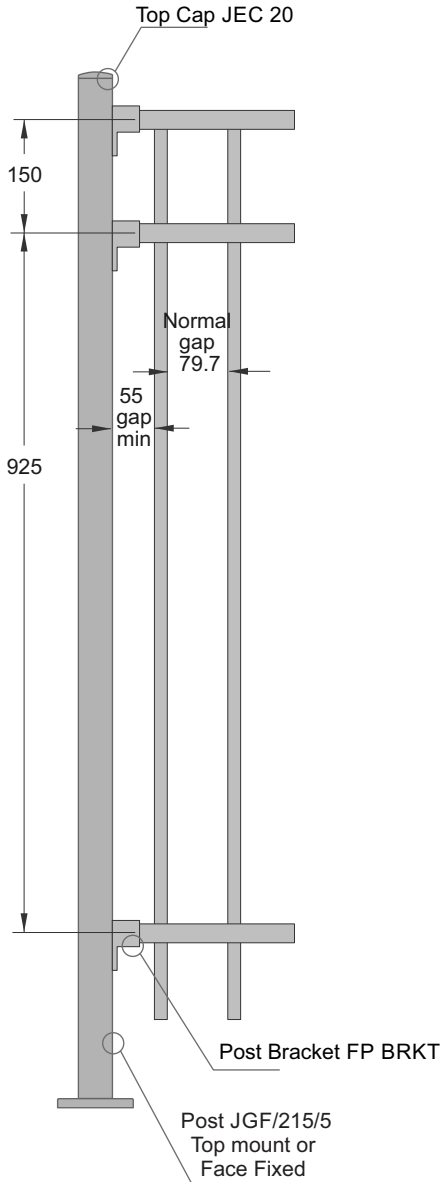
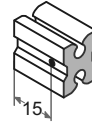

- 2 - Drill 2 x holes 3mm dia
at correct positions to suit Spigot
- All by 3 x per Post
Note offset to people side.

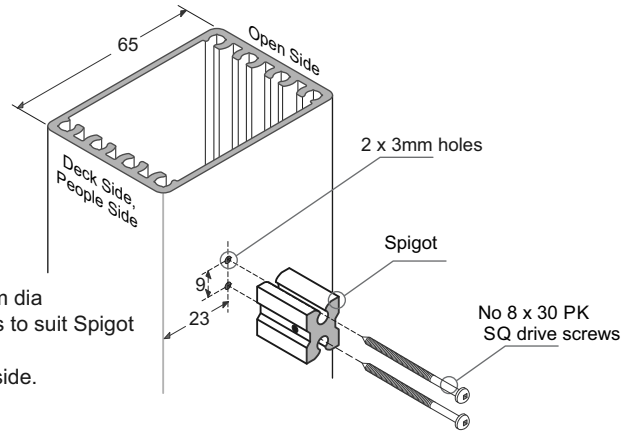

- 3 - Pre Drill 3 x rail ends for
No8 x 12 C/S PK.
-Pre-drill Post Bracket x 2 for SS Pop Rivets.
One on top, one on non spigot side
- Slide Post Bracket over Rail.
- Screw attach Rail to Spigot
- All by 3 x per Post

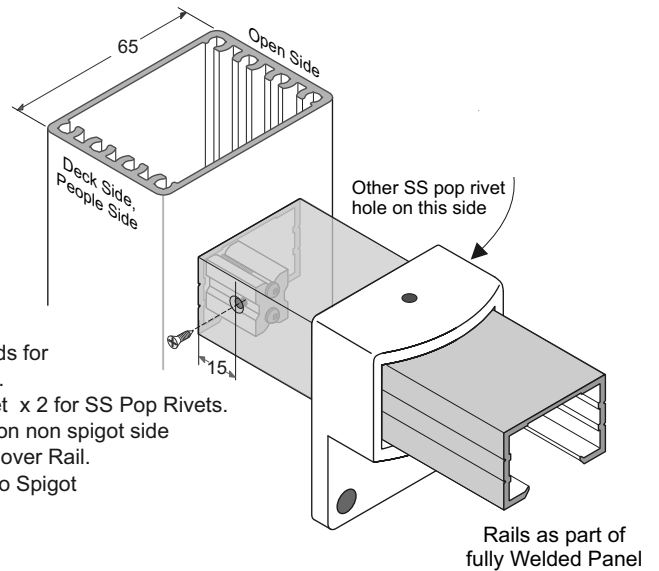

- 4 - Drill through x 2 and pop rivet x 2
Post Bracket to Rail
- Drill through and attach Post bracket
to Post with 3 x SS TEK screws.
- All by 3 x per Post

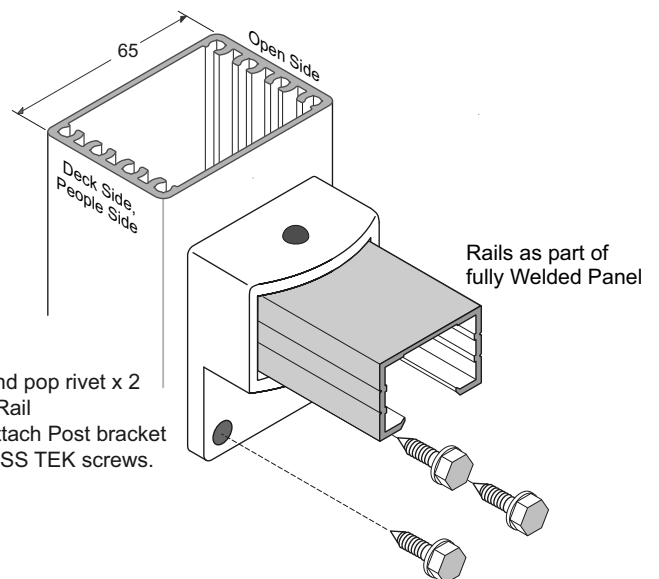

Juralco Contemporary Balustrade System - Angle Bracket, Post Fixing

This Bracket for Balustrades on Curved runs and for Raked Panels

Attach to Balustrade Post
Bracket FPR BRKT/A

Bracket for Angled connections

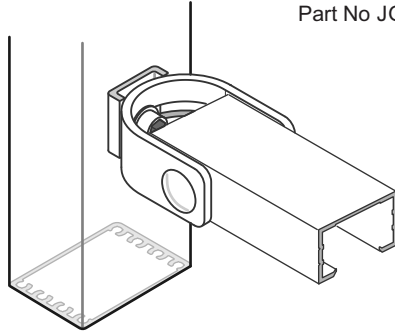
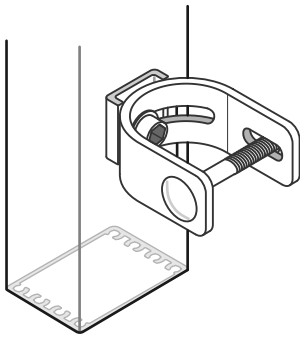

Drill 9mm hole in Post.
Attach Post Bracket with
1 x M6 Rivnut

POST
Part No JGF/215/5

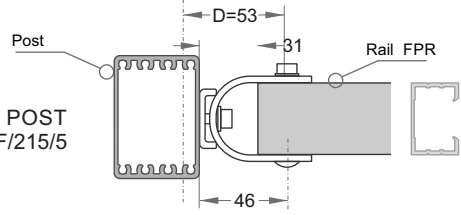

Rail cutting Allowance

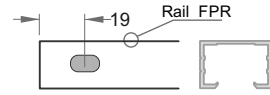

Racking rail comes standard with
a pre punched 14mm x 8mm Slot

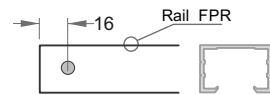

If cutting drill hole 8mm dia

Horizontal Angle Allowance
Bracket FPR BRKT/A

Bracket for Angled connections

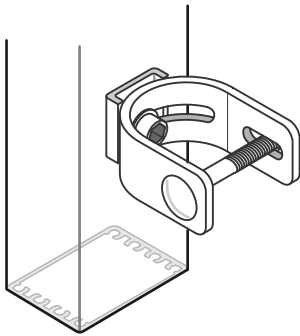

Drill 9mm hole in Post.
Attach Post Bracket with
1 x M6 Rivnut

POST
Part No JGF/215/5

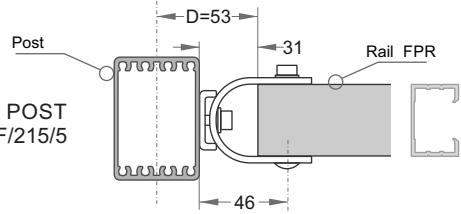

Rail cutting Allowance

Because of tolerances in Rail clamp bolt
and Drilled hole, Dimension D will stay
at about 53mm regardless of angle

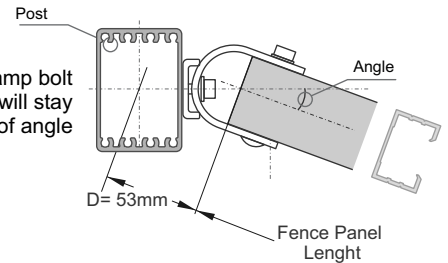

Vertical Angle Allowance
Bracket FPR BRKT/A

Bracket for Raked connections

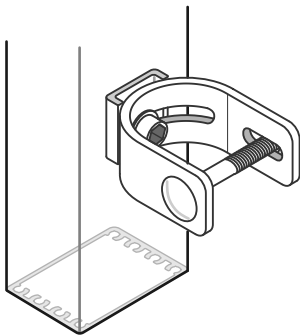

Drill 9mm hole in Post.
Attach Post Bracket with
1 x M6 Rivnut

POST
Part No JGF/215/5

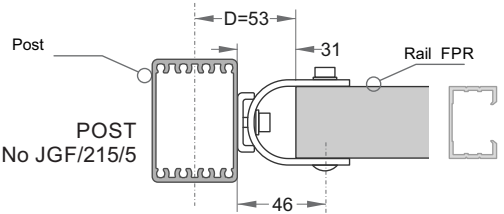

Rail cutting Allowance

Juralco Contemporary Balustrade System - Hand Rail + Hand Rail Bracket

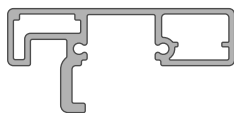
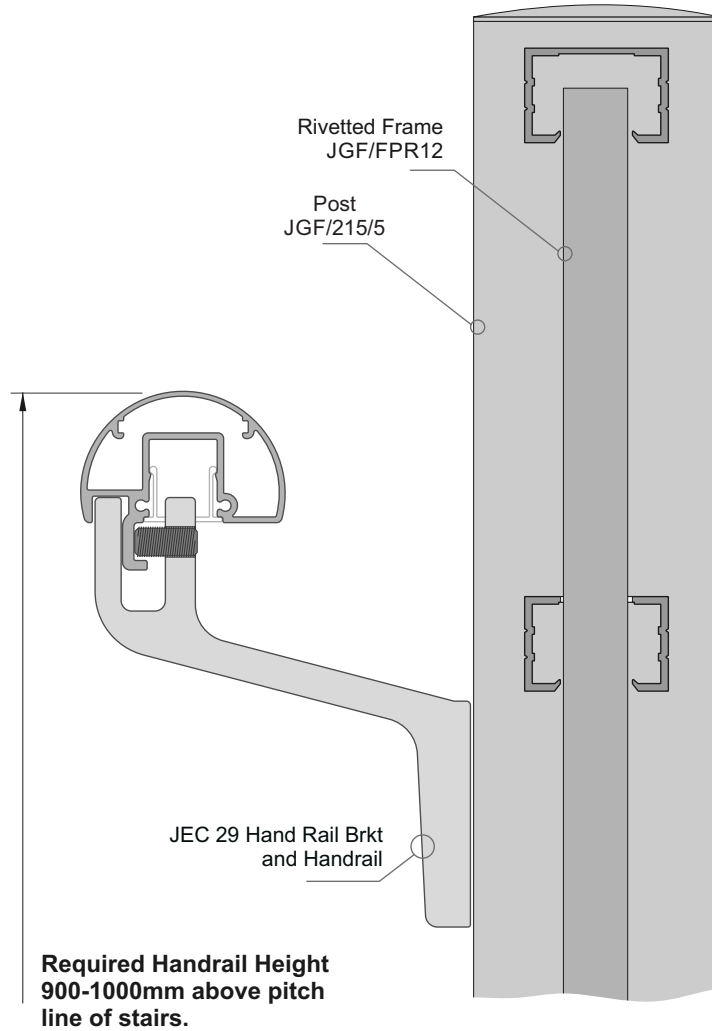

INTERLINKING RAIL
Part No JEB/222/5.8

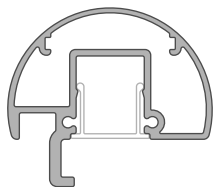

ROUND HANDRAIL
Part No JEB/209/5.8

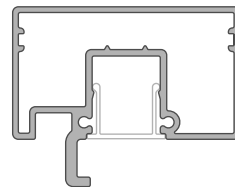

RECTANGULAR HANDRAIL
Part No JEB/216/5.8

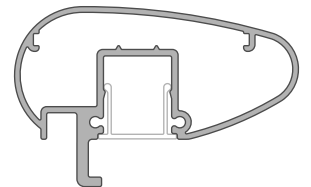

AEROFOIL HANDRAIL
Part No JEB/217/5.8

Suitable Handrails for Attaching Contemporary Balustrade to Stairs

Juralco Homestead Balustrade System - Typical Post Mount Options

Gutter Bracket - Face Fixed
Allows for Guttering to run under. Different fasteners types depending on the Building substrate

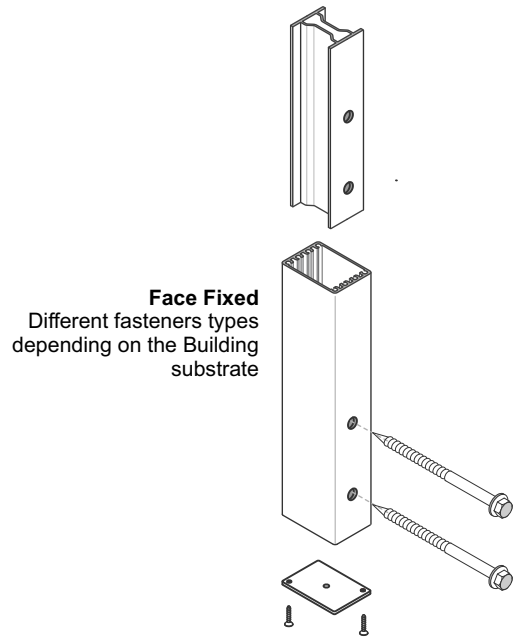
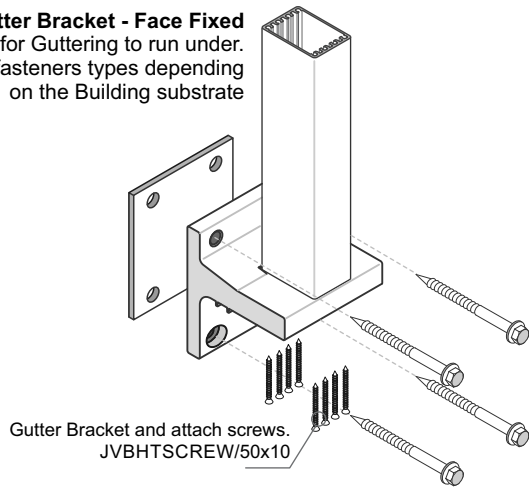

Face Fixed
Different fasteners types depending on the Building substrate

Top Mount
Base Plates in a variety of sizes. Different Base plates and fasteners types depending on the Building substrate.

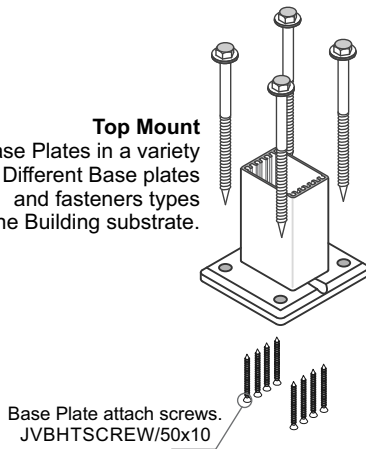

Base Plate attach screws. JVBHTSCREW/50x10

Top Mount
Concrete only. Post cemented permanently in place

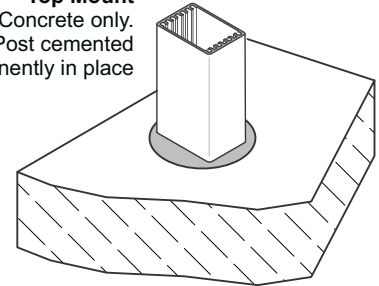

Top Fix - Sleeve-It
Into Ground, for Retaining Walls

Note: The Sleeve-It product is to be covered by the Retaining Wall systems PS1 and is therefore excluded from the Juralco Contemporary Balustrade's PS1

Notes re Mounting to Timber using a Preprimed Fascia

Fascia Specs

Must be Straight and true 180mm x 18mm Preprimed H3.1 Pine FJ. Painted, 15yr min durability.
Predrill 8mm dia + C/sink for No8 x 40mm SS C/S Woodscrews between mounting positions to hold the Fascia board in place.
You may predrill the Fascia board with all the Mounting holes if desired.
No Packing of Fascia Board, must be directly mounted to Boundary Joists

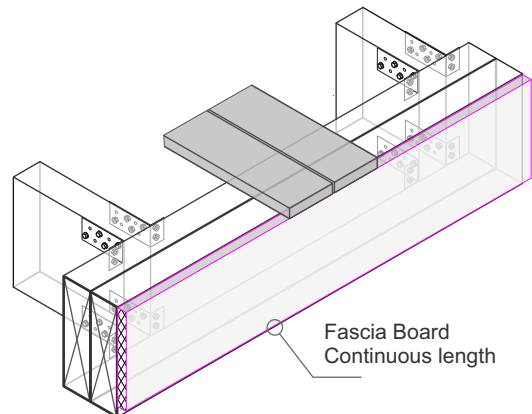

Juralco Contemporary Balustrade Systems - Typical Post Fixing
Complies NZS3604:2011 - Double Boundary Joists

Typical TOP Fix to Timber - JEC 221, 110mm x 90mm, 4 hole Base Plate - M10 SS Coachscrews

**Up to and including
Extra High Wind Zone**

These Height/Spacings
apply to this Mounting
Type only

MAX Post Centres	1480
Panel Length	1435
MAX Height - From Deck to Top of Infill Panel	1275

General Notes:

- 1 - All measurements mm
- 2 - Balustrade Height, above Deck
- 3 - Conforms to NZ building Code and AS/NZ1170 regulations
- 4 - For Residential and Commercial C3 applications up to 1275mm high
- 5 - Not suitable for fixing directly to stairs without attached Handrail

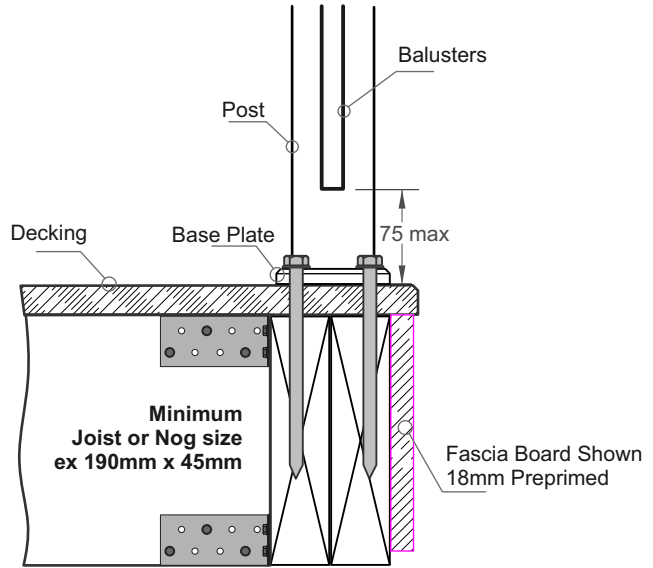

Important Installation notes:

- 1 - The Project Engineer must ensure the structure can support the appropriate loads
- 2 - Substructure shown indicatively only. Timber SG8 minimum strength
- 3 - Coachscrews 130mm engagement into joists. All coachscrews predrill 6mm holes
- 4 - Bond all coachscrews with SIKA Supergrip to full depth
- 5 - All Fixings must be Stainless steel

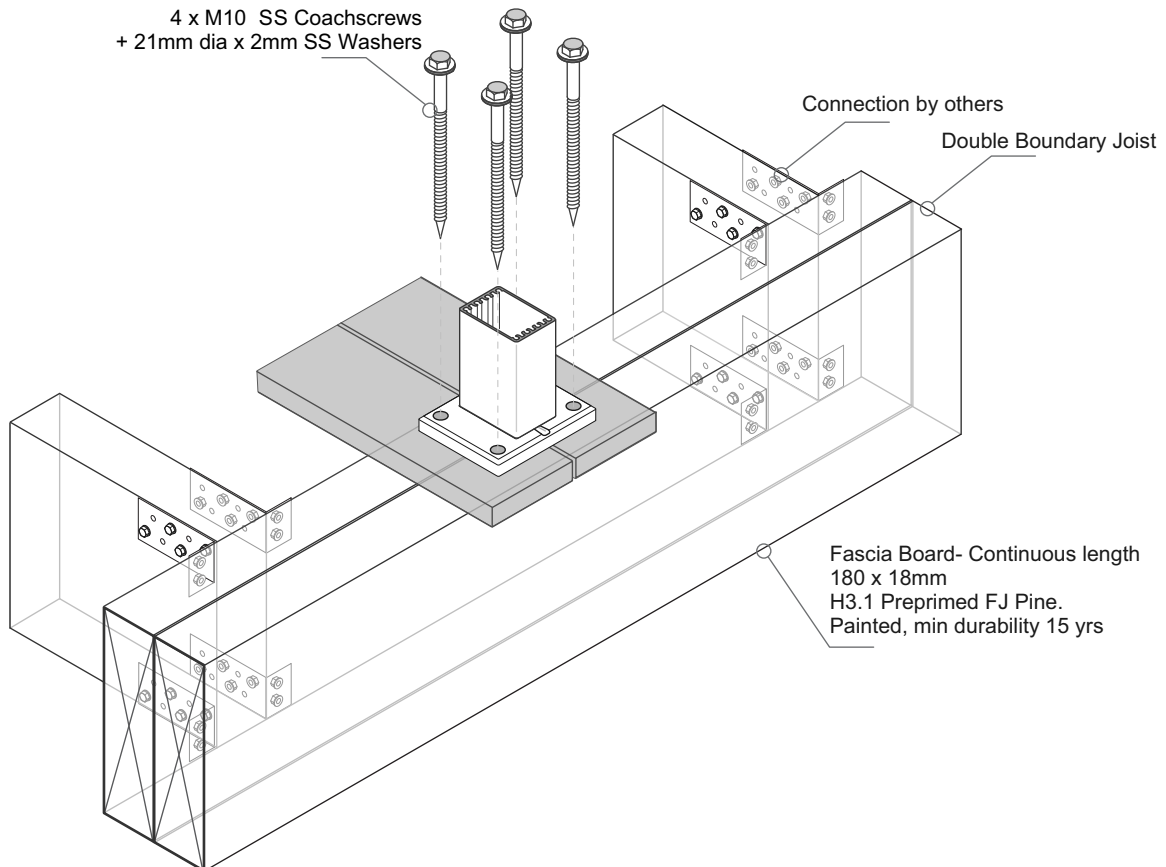

Juralco Contemporary Balustrade Systems - Typical Post Fixing
Complies NZS3604:2011 - Double Boundary Joists

Typical FACE Fix Post to Timber - M12 SS Coachscrews

**Up to and including
Extra High Wind Zone**

These Height/Spacings
apply to this Mounting
Type only

MAX Post Centres	1480
Panel Length	1435
MAX Height - From Deck to Top of Infill Panel	1270

General Notes:

- 1 - All measurements mm
- 2 - Balustrade Height, above Deck
- 3 - Conforms to NZ building Code and AS/NZ1170 regulations
- 4 - For Residential and Commercial C3 applications up to 1275mm high
- 5 - Not suitable for fixing directly to stairs without attached Handrail

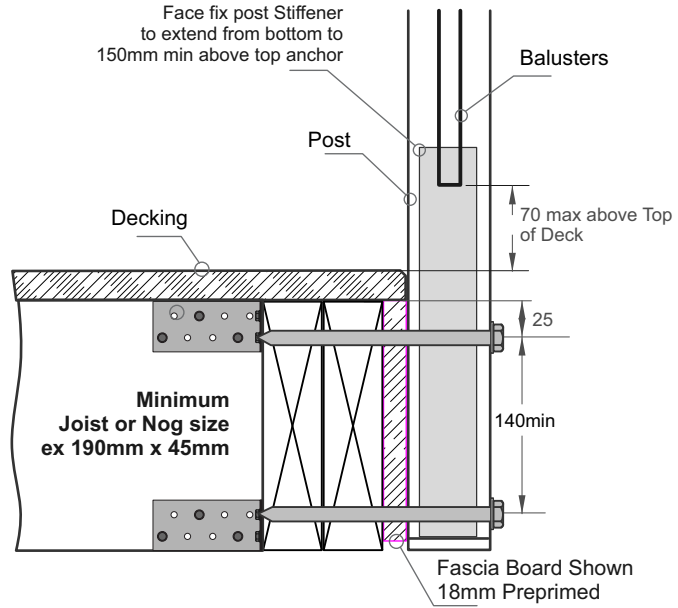

Important Installation notes:

- 1 - The Project Engineer must ensure the structure can support the appropriate loads
- 2 - Substructure shown indicatively only. Timber SG8 minimum strength
- 3 - Coachscrews 90mm engagement into joists. All coachscrews predrill 6mm holes
- 4 - Bond all coachscrews with SIKA Supergrip to full depth
- 5 - All Fixings must be Stainless steel

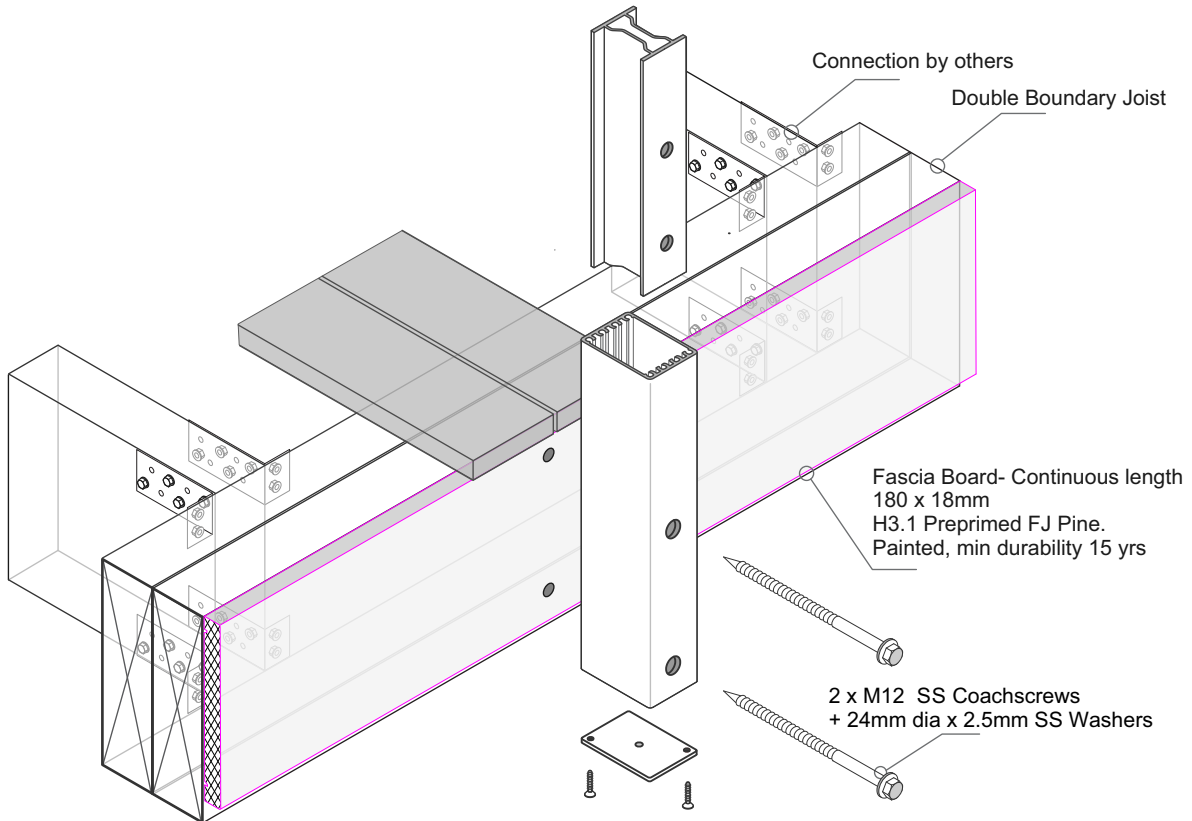

Juralco Contemporary Balustrade Systems - Typical Post Fixing
Complies NZS3604:2011 - Double Boundary Joists

Typical FACE Fix Post to Timber - M10 SS Bolts or M10 SS Threaded Rod

**Up to and including
Extra High Wind Zone**

These Height/Spacings
apply to this Mounting
Type only

MAX Post Centres	1480
Panel Length	1435
MAX Height - From Deck to Top of Infill Panel	1270

General Notes:

- 1 - All measurements mm
- 2 - Balustrade Height, above Deck
- 3 - Conforms to NZ building Code and AS/NZ1170 regulations
- 4 - For Residential and Commercial C3 applications up to 1275mm high
- 5 - Not suitable for fixing directly to stairs without attached Handrail

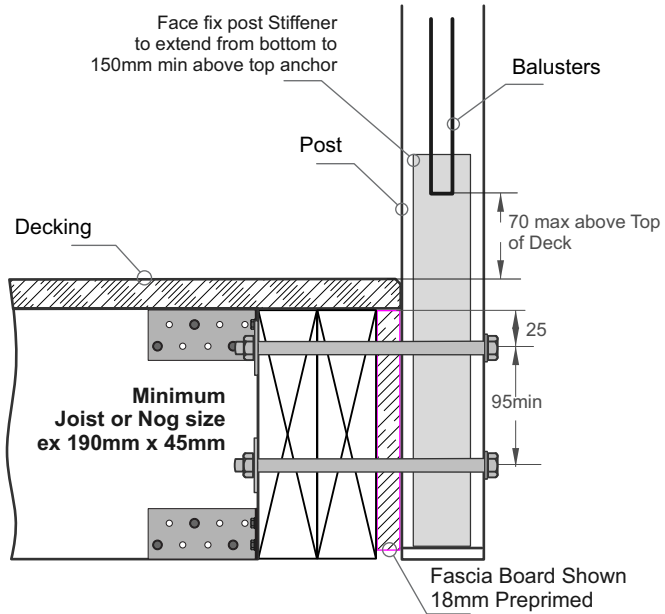

Important Installation Notes:

- 1 - A Project engineer must ensure the structure can support the appropriate loading at each Post
- 2 - If using Threaded Rod use Threadlok on Dome Nuts
- 3 - All fixings must be Stainless Steel

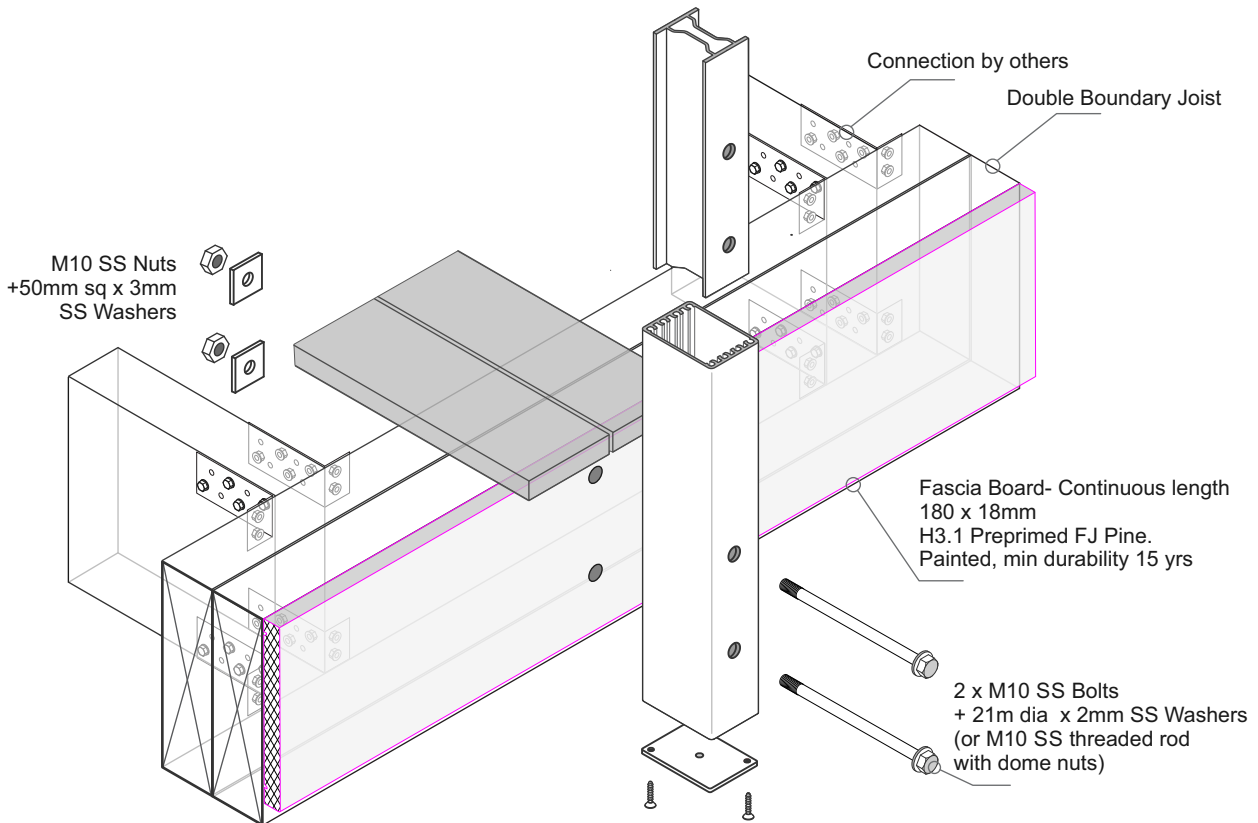

**Juralco Contemporary Balustrade Systems - Typical Post Fixing
Complies NZS3604:2011 - Double Boundary Joists**

Typical FACE Fix Post to Timber Deck - M12 SS Coachscrews and Spacers

**Up to and including
Extra High Wind Zone**

These Height/Spacings
apply to this Mounting
Type only

MAX Post Centres	1480
Panel Length	1435
MAX Height - From Deck to Top of Infill Panel	1270

General Notes:

- 1 - All measurements mm
- 2 - Balustrade Height, above Deck
- 3 - Conforms to NZ building Code and AS/NZ1170 regulations
- 4 - For Residential and Commercial C3 applications up to 1275mm high
- 5 - Not suitable for fixing directly to stairs without attached Handrail

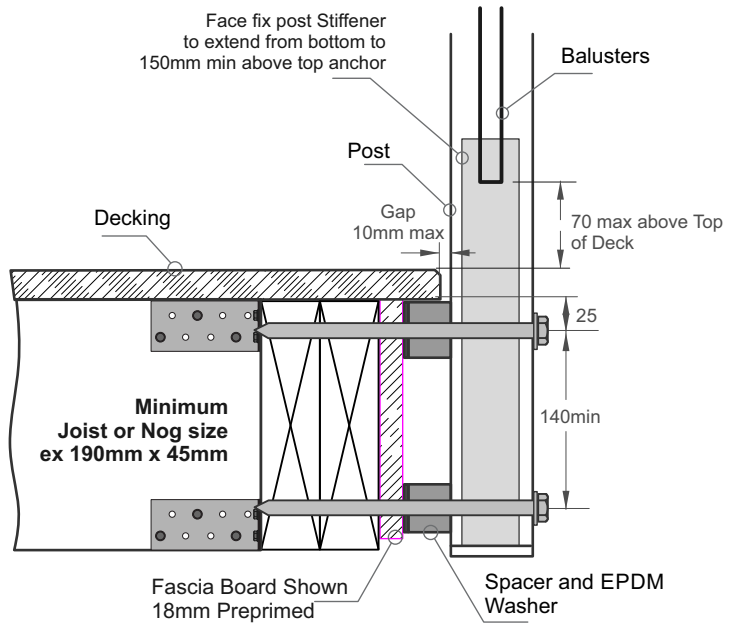

Important Installation notes:

- 1 - The Project Engineer must ensure the structure can support the appropriate loads
- 2 - Substructure shown indicatively only. Timber SG8 minimum strength
- 3 - Coachscrews 90mm engagement into joists. All coachscrews predrill 6mm holes
- 4 - Bond all coachscrews with SIKA Supergrip to full depth
- 5 - All Fixings must be Stainless steel

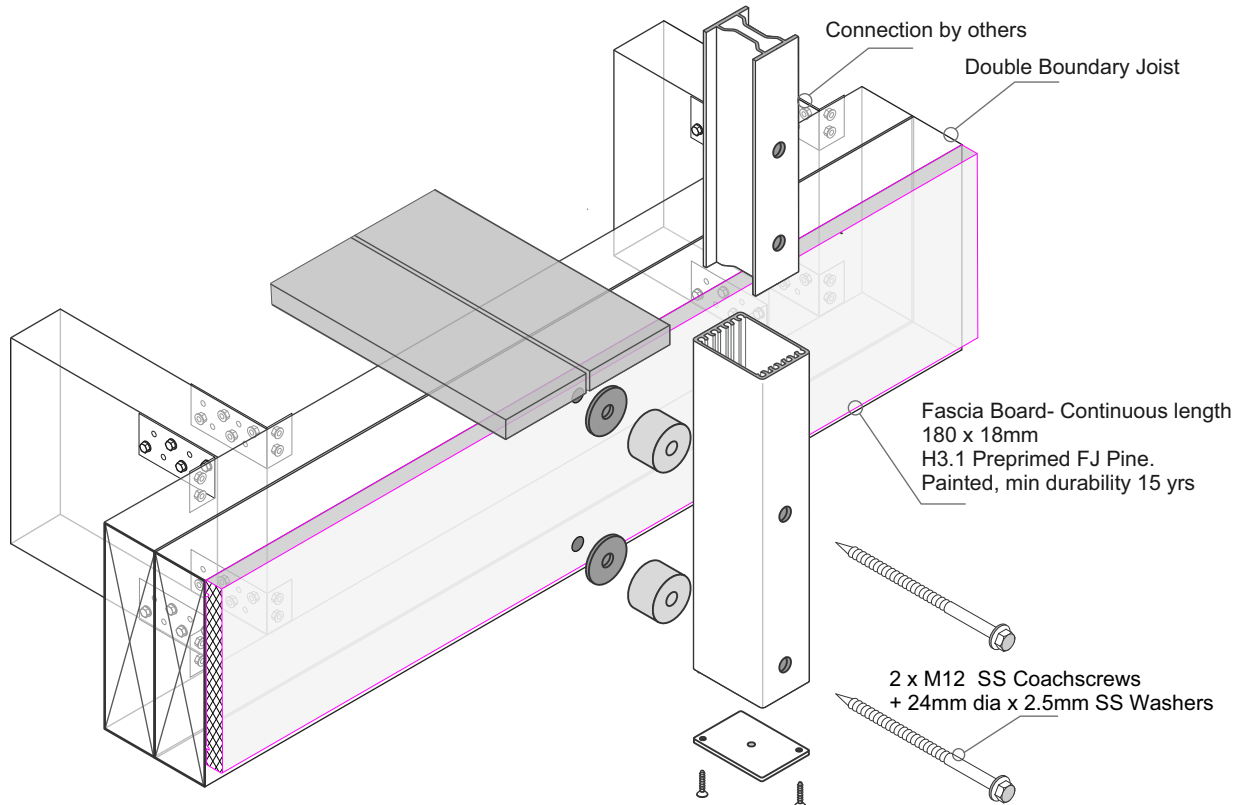

Juralco Contemporary Balustrade Systems - Typical Post Fixing
Complies NZS3604:2011 - Double Boundary Joists

Typical FACE Fix to Timber - JEC 137/65, Gutter Bracket - M10 SS Coachscrews

**Up to and including
Extra High Wind Zone**

These Height/Spacings
apply to this Mounting
Type only

MAX Post Centres	1480
Panel Length	1435
MAX Height - From Deck to Top of Infill Panel	1200

General Notes:

- 1 - All measurements mm
- 2 - Balustrade Height, above Deck
- 3 - Conforms to NZ building Code and AS/NZ1170 regulations
- 4 - For Residential and Commercial C3 applications up to 1275mm high
- 5 - Not suitable for fixing directly to stairs without attached Handrail

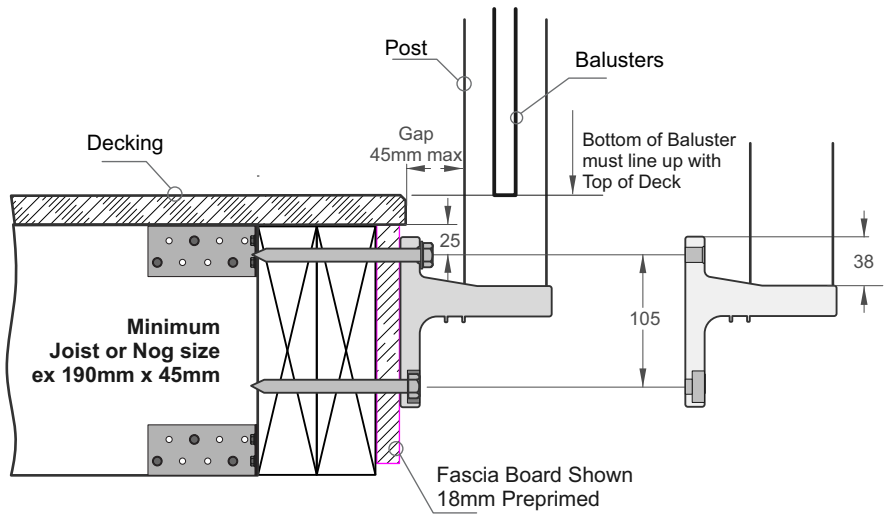

Important Installation notes:

- 1 - The Project Engineer must ensure the structure can support the appropriate loads
- 2 - Substructure shown indicatively only. Timber SG8 minimum strength
- 3 - Coachscrews 90mm engagement into joists. All coachscrews predrill 6mm holes
- 4 - Bond all coachscrews with SIKA Supergrip to full depth
- 5 - All Fixings must be Stainless steel

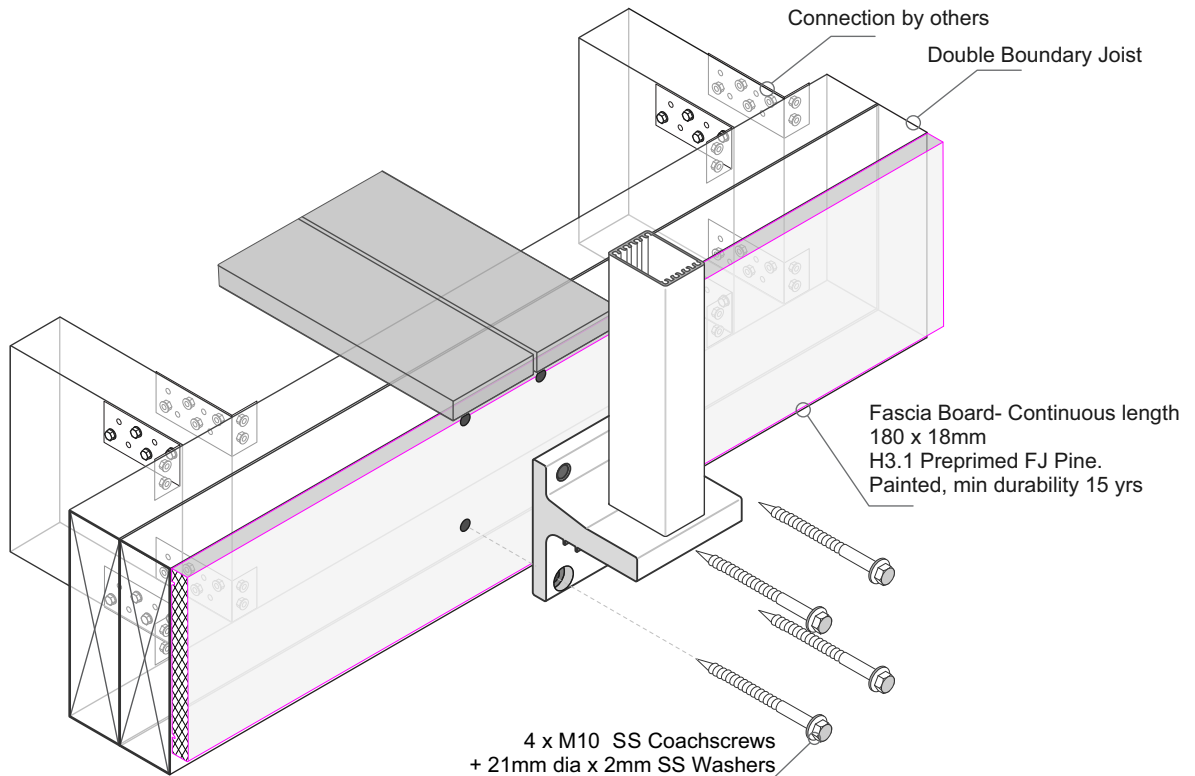

Juralco Contemporary Balustrade Systems - Typical Post Fixing
Complies NZS3604:2011 - Double Boundary Joists

Typical FACE Fix to Timber - JEC 137/65, Gutter Bracket - M10 SS Bolts or M10 SS Threaded Rod

**Up to and including
Extra High Wind Zone**

These Height/Spacings
apply to this Mounting
Type only

MAX Post Centres	1480
Panel Length	1435
MAX Height - From Deck to Top of Infill Panel	1200

General Notes:

- 1 - All measurements mm
- 2 - Balustrade Height, above Deck
- 3 - Conforms to NZ building Code and AS/NZ1170 regulations
- 4 - For Residential and Commercial C3 applications up to 1275mm high
- 5 - Not suitable for fixing directly to stairs without attached Handrail

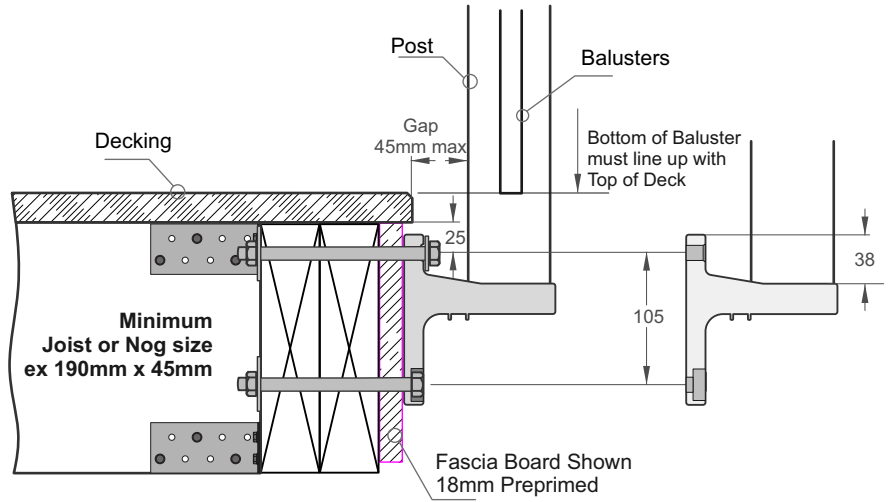

Important Installation Notes:

- 1 - A Project engineer must ensure the structure can support the appropriate loading at each Post
- 2 - If using Threaded Rod use Threadlok on Dome Nuts
- 3 - All fixings must be Stainless Steel

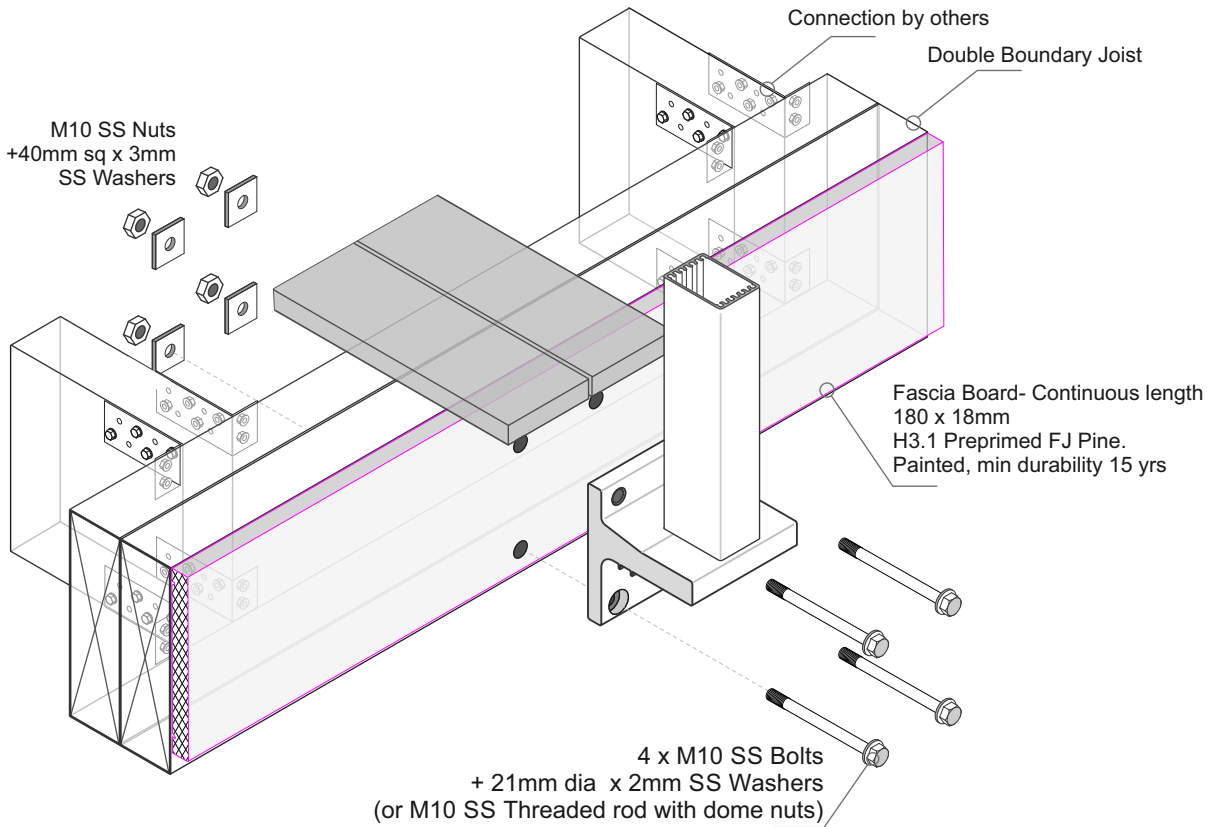

Juralco Contemporary Balustrade System - Post Mounting Details

Typical TOP Fix to Steel - JEC 201, 110mm x 90mm, 2 hole Base Plate - M10 SS Bolts

Up to and including Extra High Wind Zone

These Height/Spacings
apply to this Mounting
Type only

MAX Post Centres	1480
Panel Length	1435
MAX Height - From Deck to Top of Infill Panel	1275

General Notes:

- 1 - All measurements mm
- 2 - Balustrade Height, above Deck
- 3 - Conforms to NZ building Code and AS/NZ1170 regulations
- 4 - For Residential and Commercial C3 applications up to 1275mm high
- 5 - Not suitable for fixing directly to stairs without attached Handrail

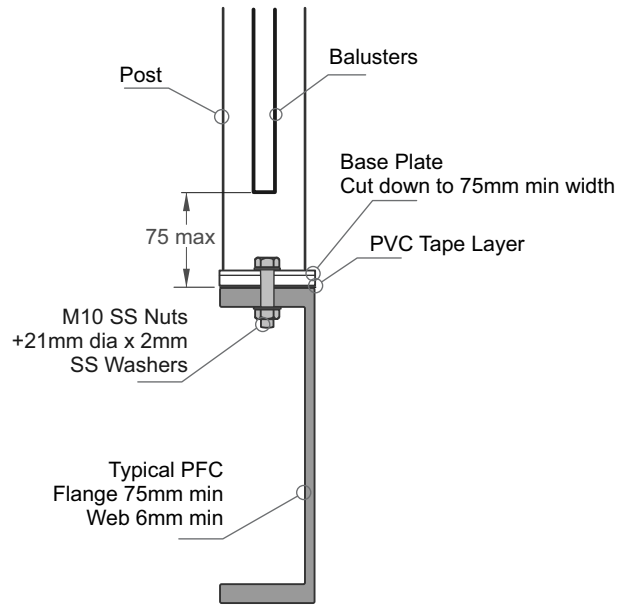

Important Installation notes:

- 1 - A Project engineer must ensure the structure can support the appropriate load
- 2 - The Baseplate can be cut down to 75mm wide
- 3 - Both Base plate and PFC must be aligned, with Bolt at C/L
- 4 - A PVC Tape layer must be installed between the Baseplate and Steel
- 5 - All fixings must be Stainless steel

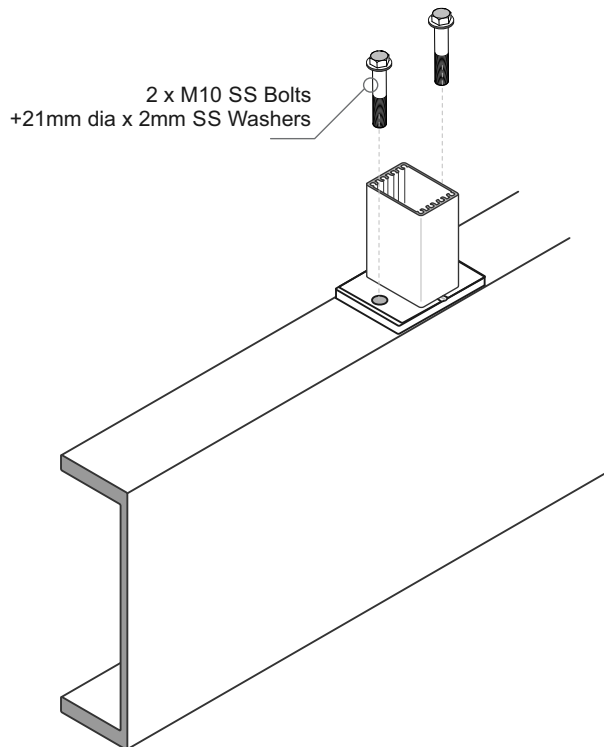

Juralco Contemporary Balustrade System - Post Mounting Details

Typical TOP Fix to Steel - JEC 221, 110mm x 90mm, 4 hole Base Plate - M10 SS Bolts

Up to and including Extra High Wind Zone

These Height/Spacings
apply to this Mounting
Type only

MAX Post Centres	1480
Panel Length	1435
MAX Height - From Deck to Top of Infill Panel	1275

General Notes:

- 1 - All measurements mm
- 2 - Balustrade Height, above Deck
- 3 - Conforms to NZ building Code and AS/NZ1170 regulations
- 4 - For Residential and Commercial C3 applications up to 1275mm high
- 5 - Not suitable for fixing directly to stairs without attached Handrail

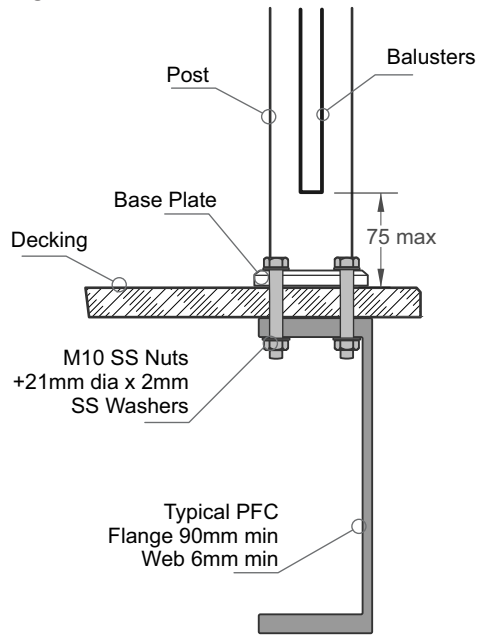

Important Installation Notes:

- 1 - A Project engineer must ensure the structure can support the appropriate loading at each Post
- 2 - All fixings must be Stainless Steel

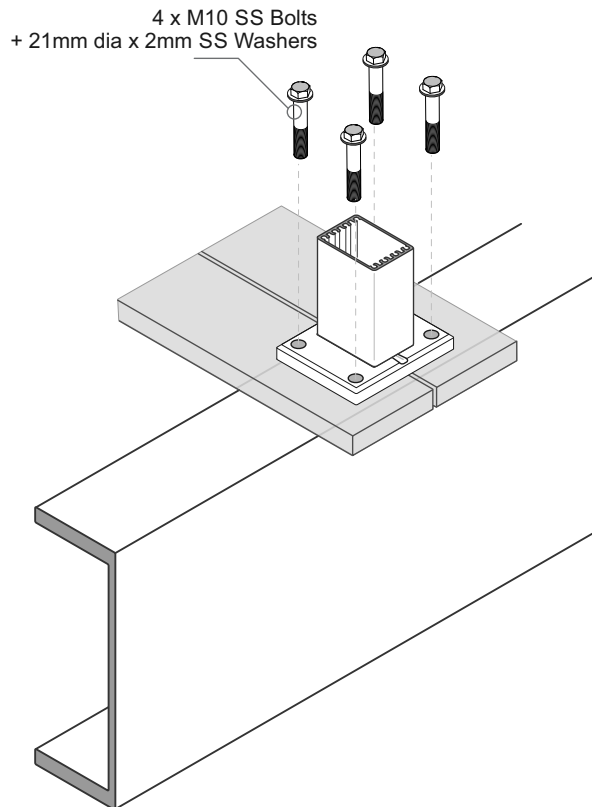

Juralco Contemporary Balustrade System - Post Mounting Details

Typical FACE Fix Post to Steel - M10 SS Bolts

Up to and including Extra High Wind Zone

These Height/Spacings apply to this Mounting Type only

MAX Post Centres	1480
Panel Length	1435
MAX Height - From Deck to Top of Infill Panel	1270

General Notes:

- 1 - All measurements mm
- 2 - Balustrade Height, above Deck
- 3 - Conforms to NZ building Code and AS/NZ1170 regulations
- 4 - For Residential and Commercial C3 applications up to 1275mm high
- 5 - Not suitable for fixing directly to stairs without attached Handrail

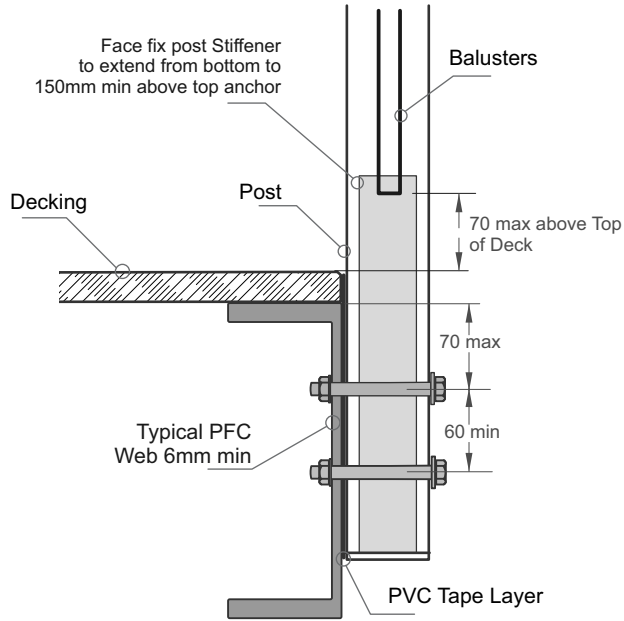

Important Installation Notes:

- 1 - A Project engineer must ensure the structure can support the appropriate loads
- 2 - A PVC Tape layer must be installed between the Post and Steel
- 3 - All fixings must be Stainless Steel

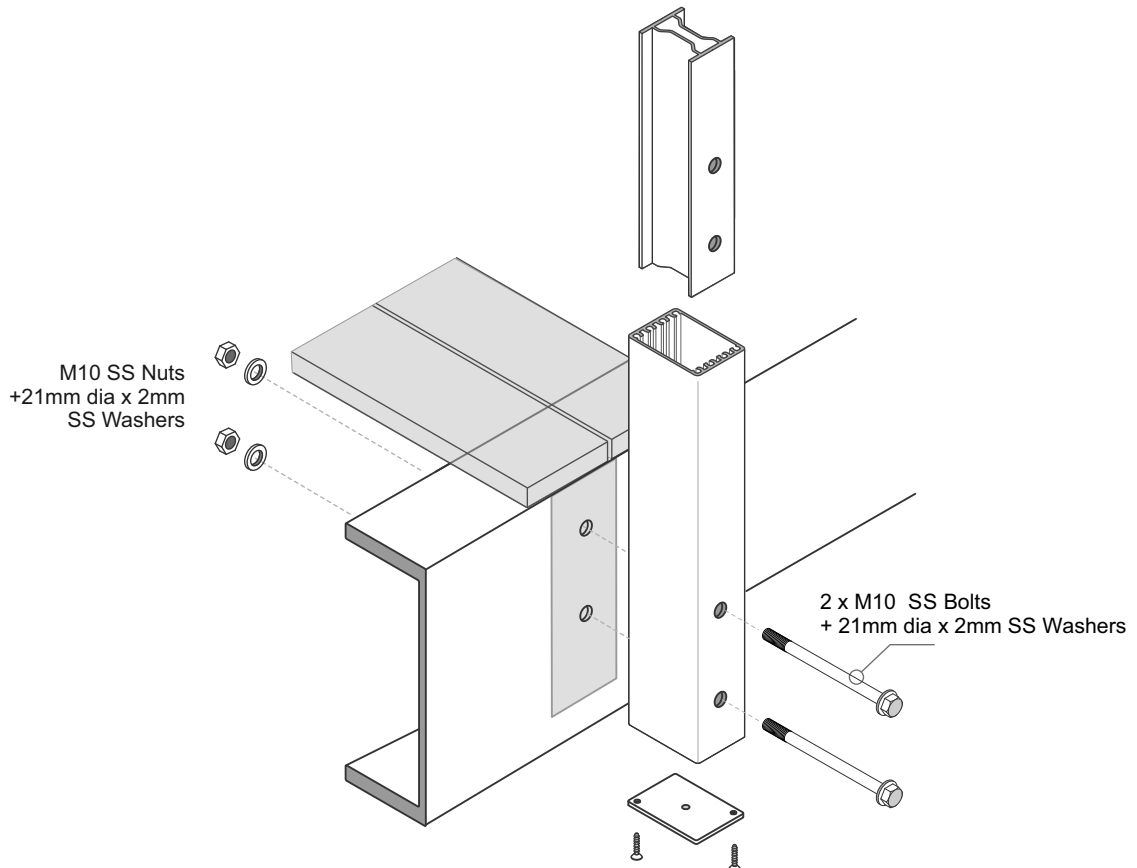

Juralco Contemporary Balustrade System - Post Mounting Details

Typical FACE Fix Post to Steel, Wooden Packers - M10 SS Bolts

**Up to and including
Extra High Wind Zone**

These Height/Spacings
apply to this Mounting
Type only

MAX Post Centres	1480
Panel Length	1435
MAX Height - From Deck to Top of Infill Panel	1270

General Notes:

- 1 - All measurements mm
- 2 - Balustrade Height, above Deck
- 3 - Conforms to NZ building Code and AS/NZ1170 regulations
- 4 - For Residential and Commercial C3 applications up to 1275mm high
- 5 - Not suitable for fixing directly to stairs without attached Handrail

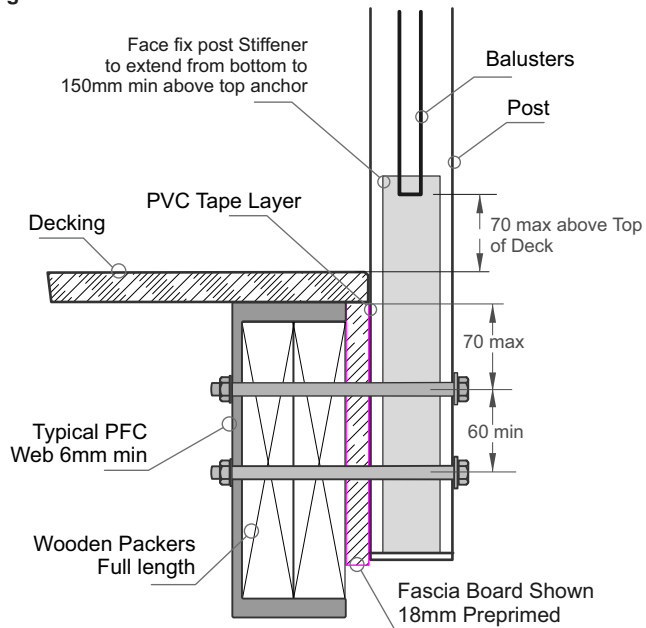

Important Installation Notes:

- 1 - A Project engineer must ensure the structure can support the appropriate loading at each Post
- 2 - There must be a PVC Tape layer installed on the Top steel flange
- 2 - All fixings must be Stainless Steel

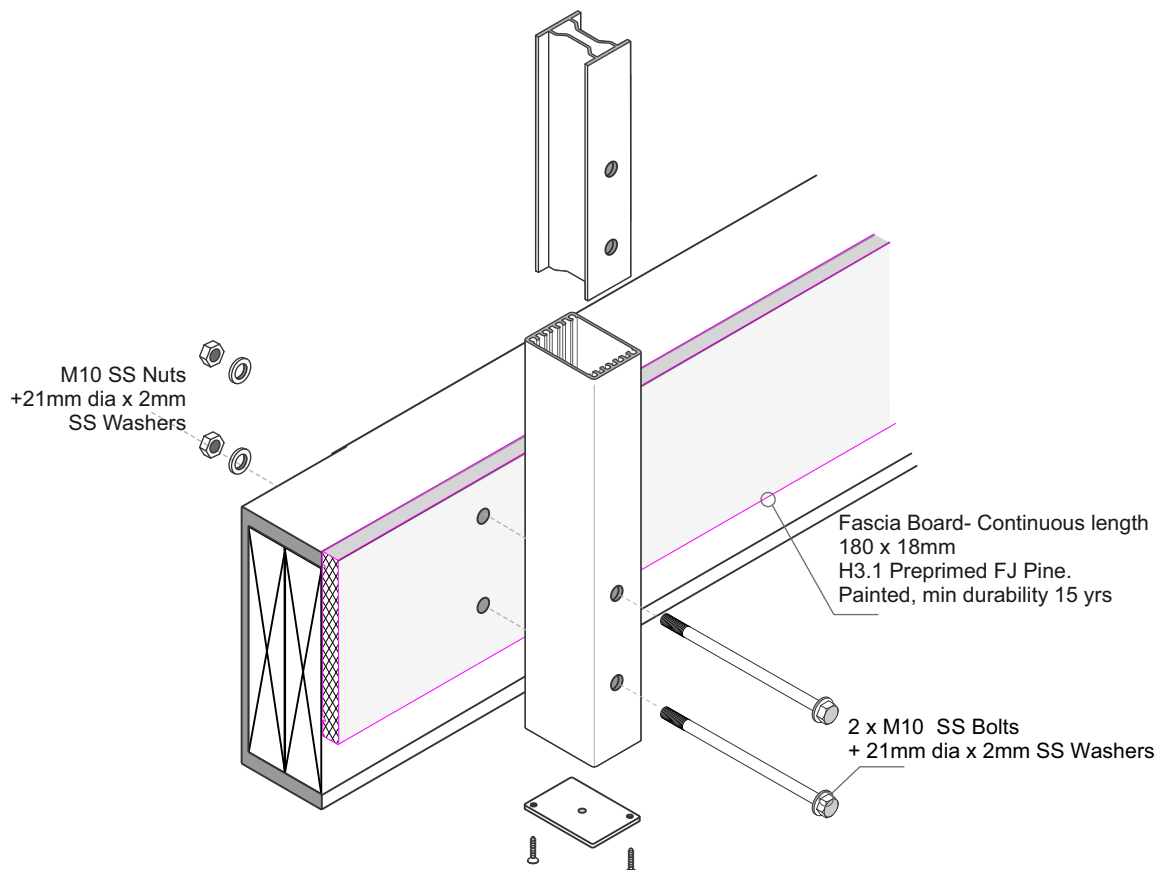

Juralco Contemporary Balustrade System - Post Mounting Details

Typical TOP Fix to Concrete Path - JEC 221, 110mm x 90mm, 4 hole Base Plate for M10 SS Studs A4-70 + Fischer FIS V

Up to and including Extra High Wind Zone

These Height/Spacings apply to this Mounting Type only

MAX Post Centres	1480
Panel Length	1435
MAX Height - From Deck to Top of Infill Panel	1275

General Notes:

- 1 - All measurements mm
- 2 - Balustrade Height, above Deck
- 3 - Conforms to NZ building Code and AS/NZ1170 regulations
- 4 - For Residential and Commercial C3 applications up to 1275mm high
- 5 - Not suitable for fixing directly to stairs without attached Handrail



Installation details Fischer FIS V 300T

Thread diameter M10
 Drill hole diameter = 12 mm
 Drill hole depth = 110mm
 Anchorage depth = 100mm

Drilling method Hammer drilling
 Drill hole cleaning 4 times blowing,
 4 times brushing,
 4 times blowing

No borehole cleaning required in case of using a hollow drill bit, e.g. fischer FHD.

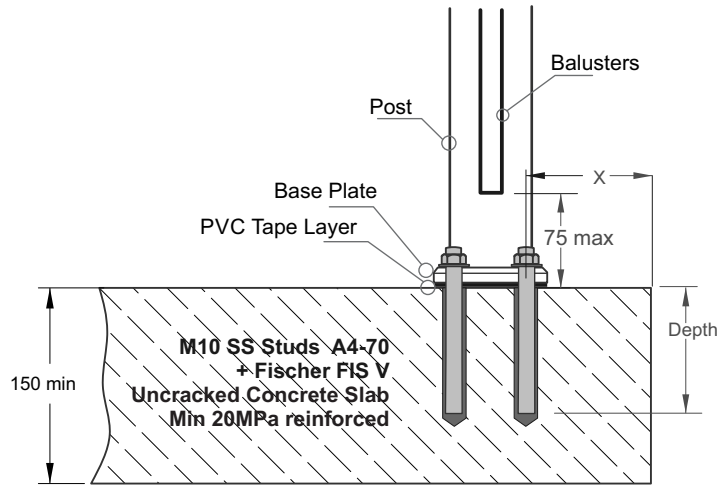

Base Plate JEC 221	X (min)	Depth (min)
4 off M10 x100 SS Studs + Fischer FIS V	85mm	100mm

Important Installation Notes:

- 1 - The Project Engineer must ensure the structure can support the appropriate loads
- 2 - Substructure shown indicatively only
- 3 - Fixings must engage into the structural slab
- 4 - A PVC Tape layer must be installed between the Baseplate and Concrete
- 5 - Use Threadlok on Nuts
- 6 - All fixings must be Stainless Steel

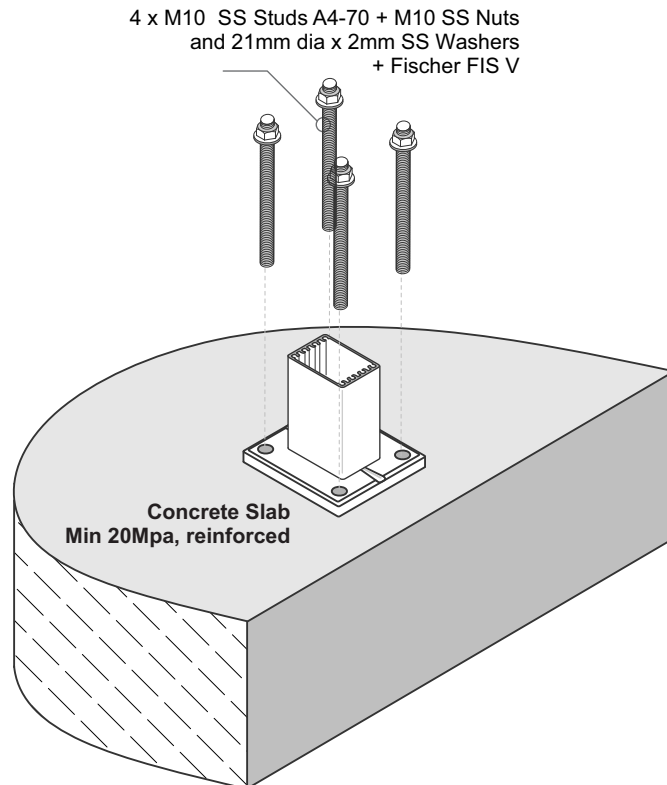

Juralco Contemporary Balustrade System - Post Mounting Details

Typical TOP Fix to Concrete - Embed Post in Concrete Slab

**Up to and including
Extra High Wind Zone**

These Height/Spacings
apply to this Mounting
Type only

MAX Post Centres	1480
Panel Length	1435
MAX Height - From Deck to Top of Infill Panel	1275

General Notes:

- 1 - All measurements mm
- 2 - Balustrade Height, above Deck
- 3 - Conforms to NZ building Code and AS/NZ1170 regulations
- 4 - For Residential and Commercial C3 applications up to 1275mm high
- 5 - Not suitable for fixing directly to stairs without attached Handrail
- 6 - Only suitable for Ground Level sites (Not elevated)

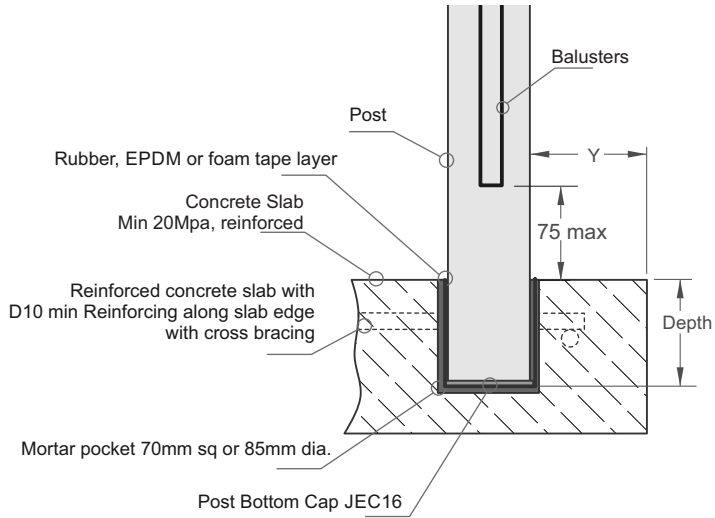

Concrete Type	Y (min)	Depth (min)
Reinforced Slab	70mm	95mm

Important Installation Notes:

- 1 - A Project engineer must ensure the structure can support the appropriate loading at each Post
- 2 - All fixings must engage into the structural slab
- 3 - A PVC Tape layer must be installed between the Post and Concrete
- 4 - Avoid mortar splashes on exposed aluminium. Wash off immediately
- 5 - All fixings must be Stainless Steel

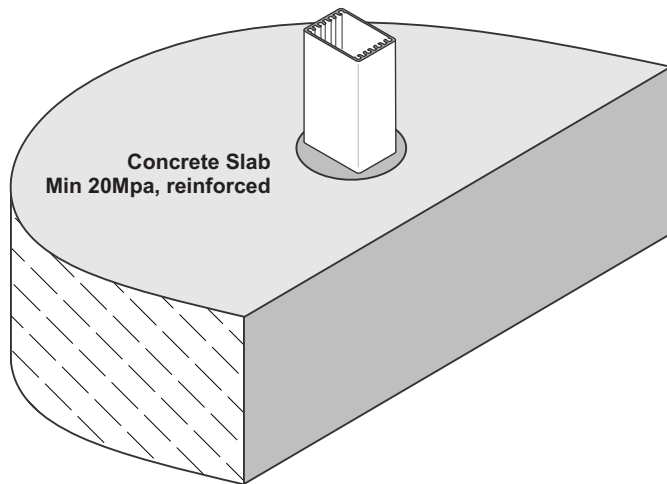

Juralco Contemporary Balustrade System - Post Mounting Details

Typical FACE Fix Post to Concrete - M10 SS Studs. For Corner Post only

Up to and including Extra High Wind Zone

These Height/Spacings apply to this Mounting Type only

MAX Post Centres	1480
Panel Length	1435
MAX Height - From Deck to Top of Infill Panel	1270

General Notes:

- 1 - All measurements mm
- 2 - Balustrade Height, above Deck
- 3 - Conforms to NZ building Code and AS/NZ1170 regulations
- 4 - For Residential and Commercial C3 applications up to 1275mm high
- 5 - Not suitable for fixing directly to stairs without attached Handrail



Installation details Fischer FIS V 300T

Thread diameter	M10
Drill hole diameter	= 12 mm
Drill hole depth	= 185mm
Anchorage depth	= 175mm

Drilling method	Hammer drilling
Drill hole cleaning	4 times blowing, 4 times brushing, 4 times blowing

No borehole cleaning required in case of using a hollow drill bit, e.g. fischer FHD.

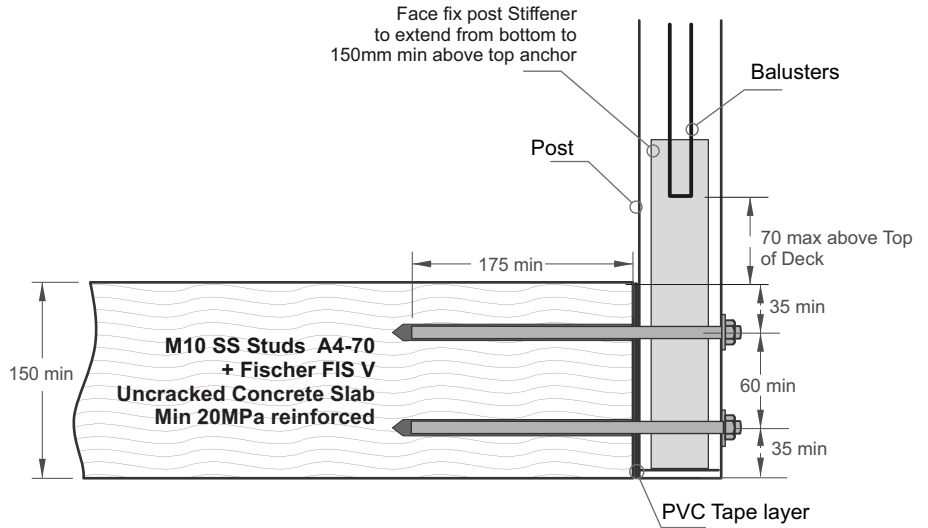

- Important Installation Notes:**
- 1 - The Project Engineer must ensure the structure can support the appropriate loads
 - 2 - Substructure shown indicatively only
 - 3 - Fixings must engage into the structural slab
 - 4 - A PVC Tape layer must be installed between the Post and Concrete
 - 5 - Use Threadlok on Nuts
 - 6 - All fixings must be Stainless Steel

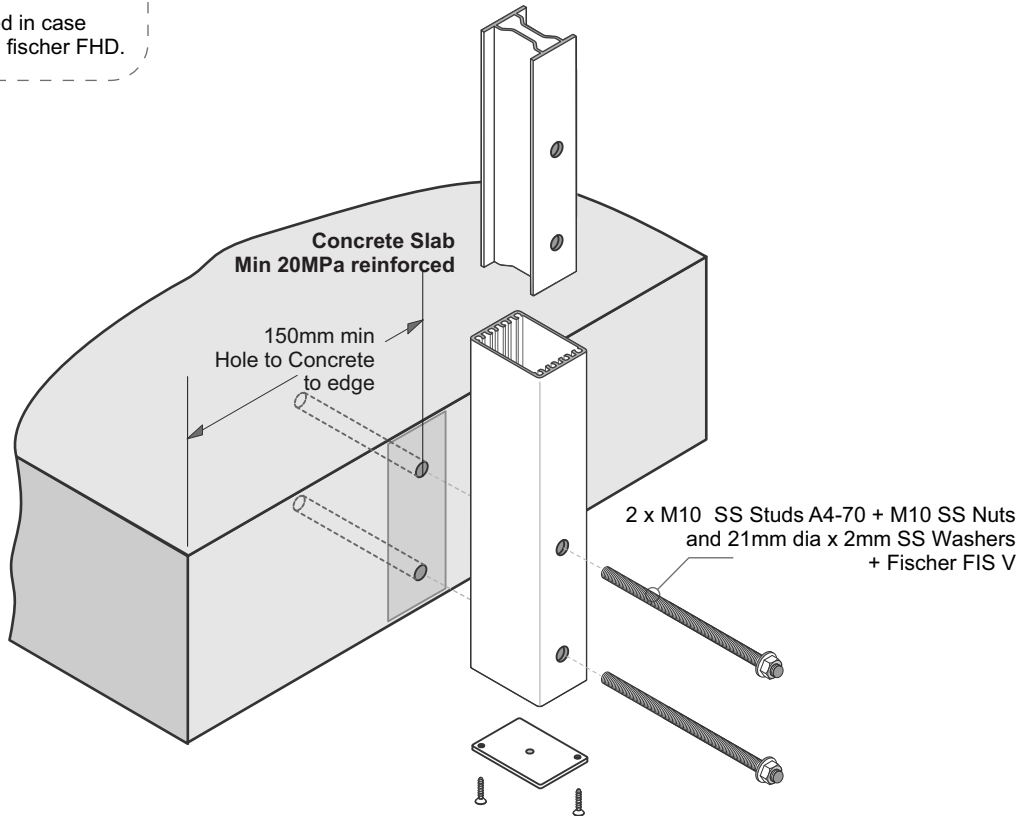

Juralco Contemporary Balustrade Systems - Typical Post Fixing
Pre NZS3604:2011 - Single Boundary Joist

Typical TOP Fix to Timber - JEC 221, 110mm x 90mm, 4 hole Base Plate - M10 SS Coachscrews

**Up to and including
Extra High Wind Zone**

These Height/Spacings
apply to this Mounting
Type only

MAX Post Centres	1480
Panel Length	1435
MAX Height - From Deck to Top of Infill Panel	1275

General Notes:

- 1 - All measurements mm
- 2 - Balustrade Height, above Deck
- 3 - Conforms to NZ building Code and AS/NZ1170 regulations
- 4 - For Residential and Commercial C3 applications up to 1275mm high
- 5 - Not suitable for fixing directly to stairs without attached Handrail

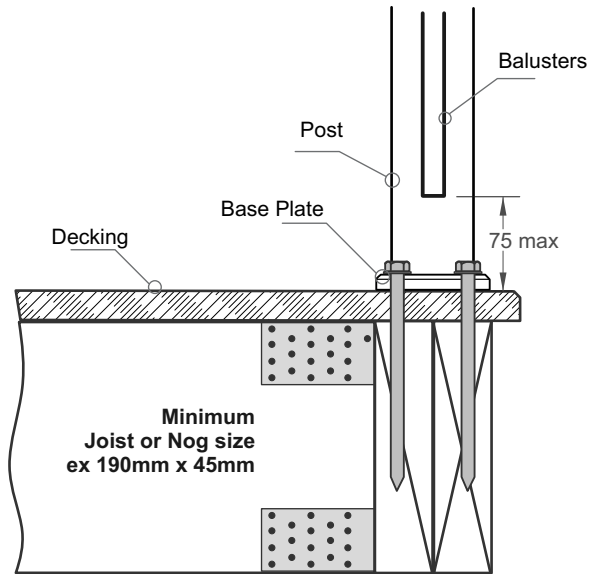

Important Installation notes:

- 1 - The Project Engineer must ensure the structure can support the appropriate loads
- 2 - Substructure shown indicatively only. Timber SG8 minimum strength
- 3 - Coachscrews 150mm engagement into joists. All coachscrews predrill 6mm holes
- 4 - Bond all coachscrews with SIKA Supergrip to full depth
- 5 - All Fixings must be Stainless steel

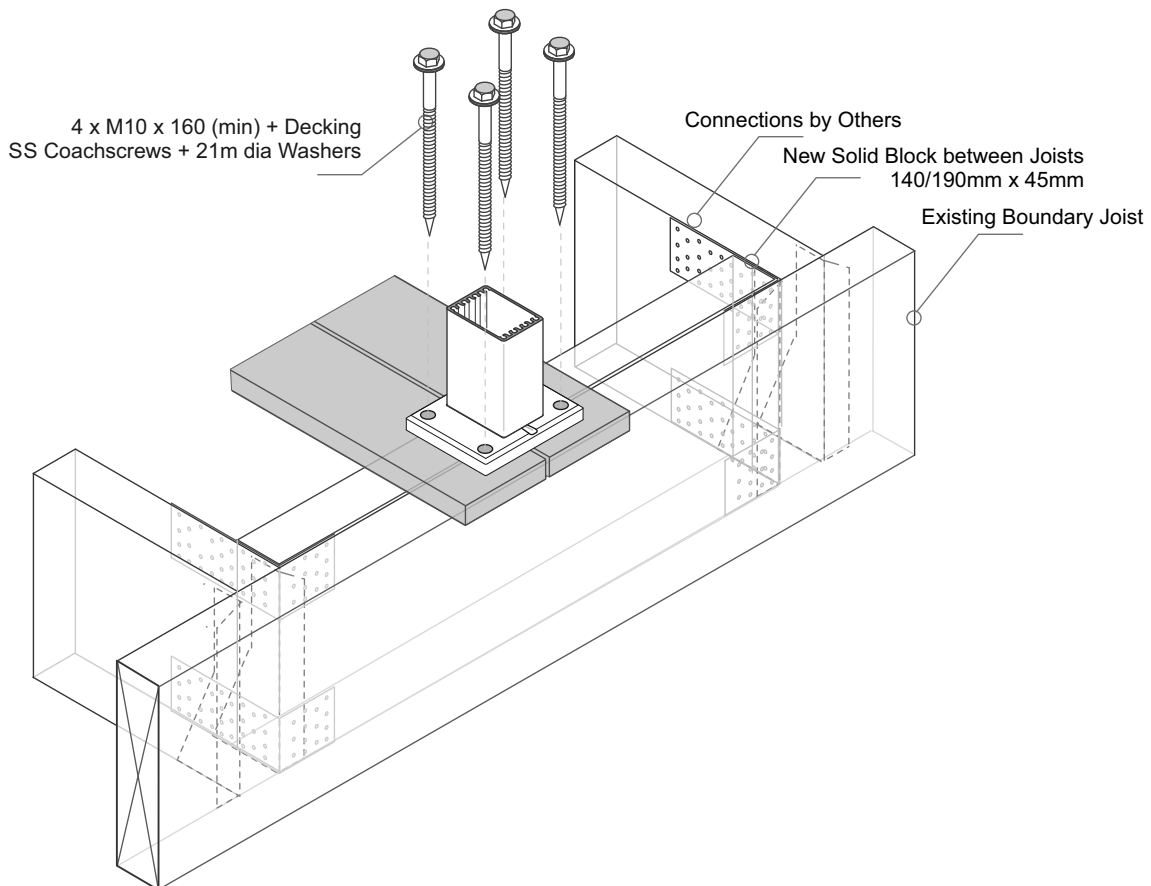

Juralco Contemporary Balustrade Systems - Typical Post Fixing
Pre NZS3604:2011 - Single Boundary Joist

Typical FACE Fix Post to Timber - M12 SS Coachscrews

**Up to and including
Extra High Wind Zone**

**These Height/Spacings
apply to this Mounting
Type only**

MAX Post Centres	1480
Panel Length	1435
MAX Height - From Deck to Top of Infill Panel	1270

General Notes:

- 1 - All measurements mm
- 2 - Balustrade Height, above Deck
- 3 - Conforms to NZ building Code and AS/NZ1170 regulations
- 4 - For Residential and Commercial C3 applications up to 1275mm high
- 5 - Not suitable for fixing directly to stairs without attached Handrail

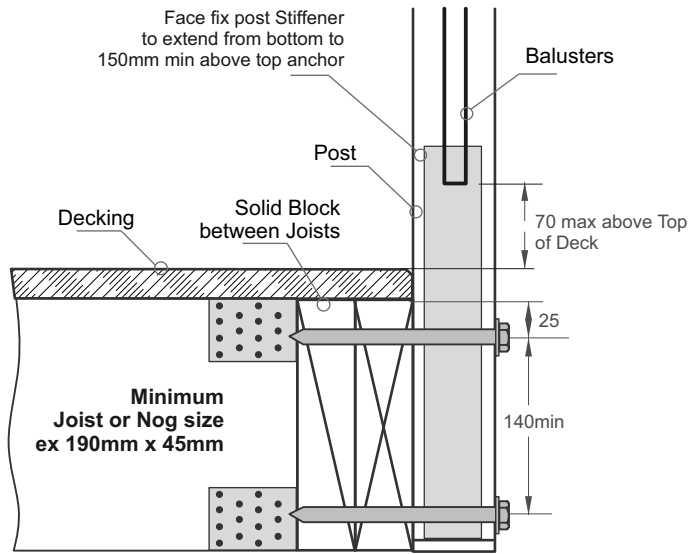

Important Installation notes:

- 1 - The Project Engineer must ensure the structure can support the appropriate loads
- 2 - Substructure shown indicatively only. Timber SG8 minimum strength
- 3 - Coachscrews 90mm engagement into joists. All coachscrews predrill 6mm holes
- 4 - Bond all coachscrews with SIKA Supergrip to full depth
- 5 - All Fixings must be Stainless steel

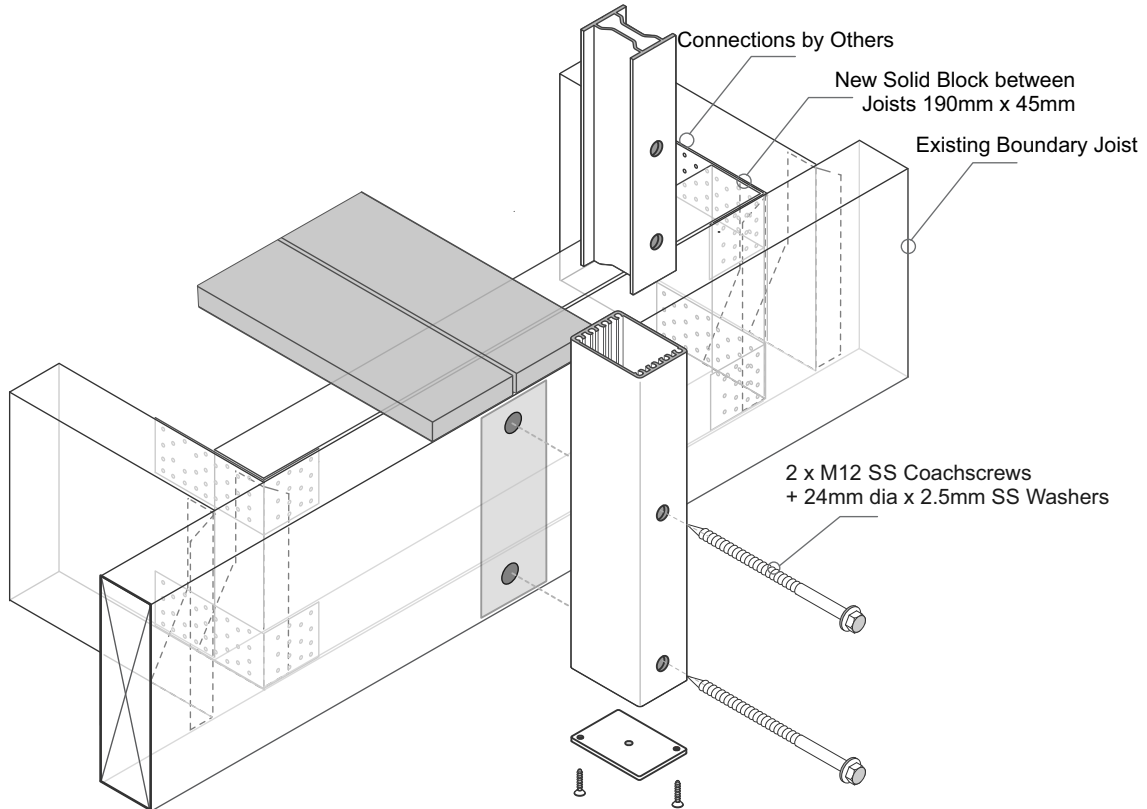

Juralco Contemporary Balustrade Systems - Typical Post Fixing Pre NZS3604:2011 - Single Boundary Joist

Typical FACE Fix Post to Timber - M10 SS Bolts or M10 SS Threaded Rod

**Up to and including
Extra High Wind Zone**

These Height/Spacings
apply to this Mounting
Type only

MAX Post Centres	1480
Panel Length	1435
MAX Height - From Deck to Top of Infill Panel	1270

General Notes:

- 1 - All measurements mm
- 2 - Balustrade Height, above Deck
- 3 - Conforms to NZ building Code and AS/NZ1170 regulations
- 4 - For Residential and Commercial C3 applications up to 1275mm high
- 5 - Not suitable for fixing directly to stairs without attached Handrail

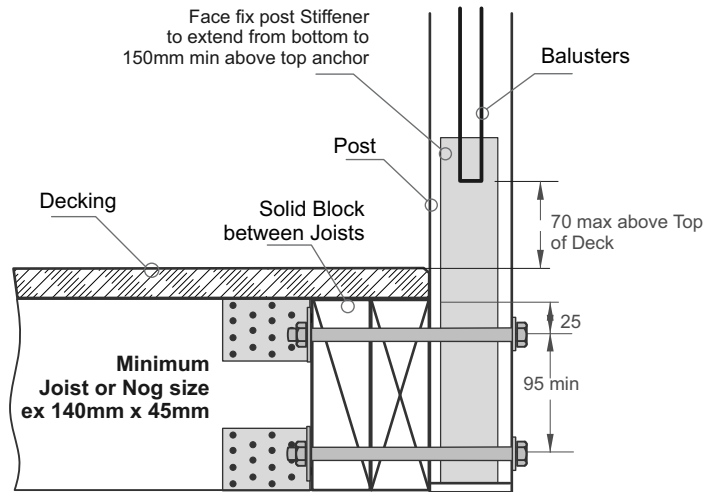

Important Installation Notes:

- 1 - A Project engineer must ensure the structure can support the appropriate loading at each Post
- 2 - All fixings must be Stainless Steel

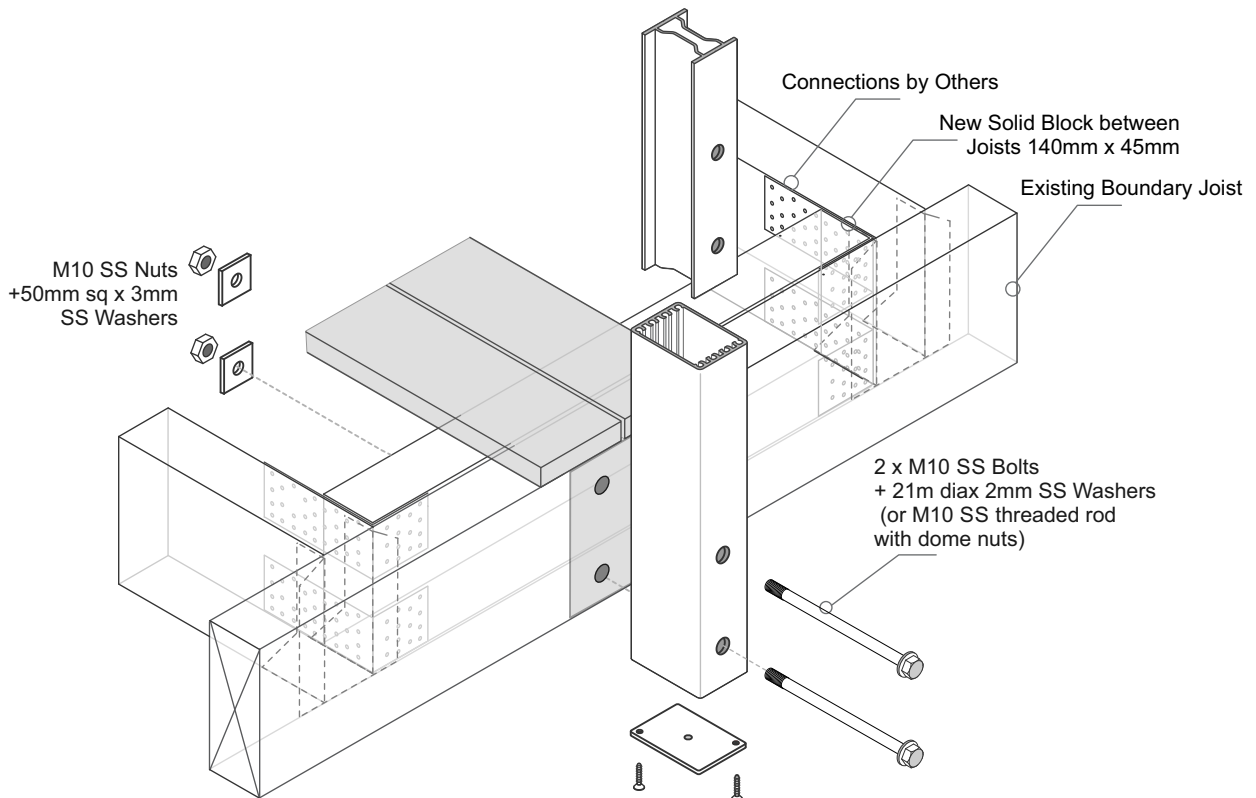

Juralco Contemporary Balustrade Systems - Typical Post Fixing For Fixing to Retaining Walls

Typical Sleeve It Post Anchor - Post to Timber Retaining Wall

For more information go to link: <https://cirtexcivil.co.nz/contact/> and in Product Search enter 'Sleeve-It'

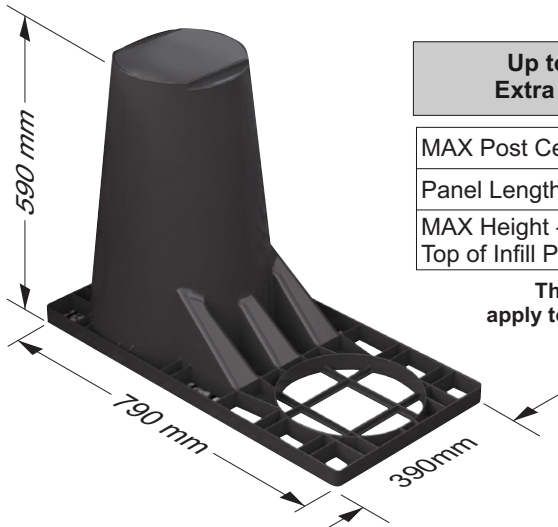

SLEEVE - IT SD1

Up to and including Extra High Wind Zone

MAX Post Centres	1480
Panel Length	1435
MAX Height - From Deck to Top of Infill Panel	1275

**These Height/Spacings
apply to this Mounting Type only**

Sleeve-It nominal dimensions are 0.59m (H) x 0.39m (W) x 0.78m (D). Each unit weighs approximately 3.2kg.

General Notes:

- 1 - All measurements mm
- 2 - Balustrade Height, above Deck
- 3 - Conforms to NZ building Code and AS/NZ1170 regulations
- 4 - For Residential and Commercial C3 applications up to 1275mm high
- 5 - Not suitable for fixing directly to stairs without attached Handrail
- 6 - Note: The Sleeve-It product is to be covered by the Retaining Wall systems PS1 and is therefore excluded from the Juralco Contemporary Balustrade's PS1
- 7 - Assumption: Sleeve-It SD1 can provide a rigid fixing to Barrier Post

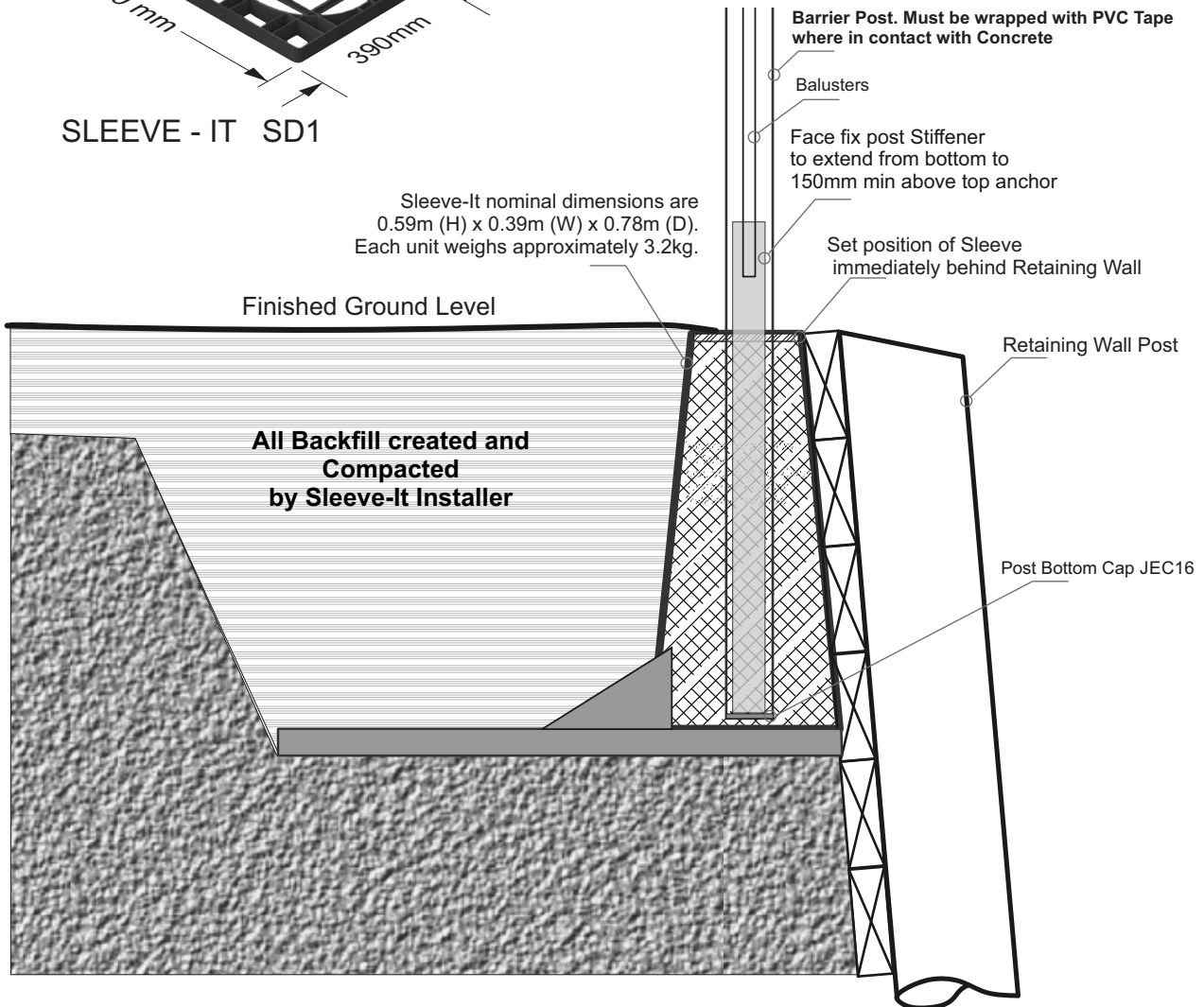

Important Installation Notes:

- 1 - A Project engineer must ensure the structure can support the appropriate loads
- 2 - Sleeve-it to be installed by Approved Installer.
- 3 - Balustrade Post + Balustrade Panels to be Installed by an Approved Juralco Installer
- 4 - Set the Sleeve-It immediately behind the retaining Wall
- 5 - Remove the Top Cap then cut a rectangle to suit the Balustrade Post
- 6 - Insert the post, holding square, then fill the Sleeve-it with Concrete
- 7 - Replace the Top cap neatly
- 8 - After Curing, assemble the Balustrade Panels between the Posts

Juralco Contemporary Balustrade Systems - Typical Post Fixing For Fixing to Retaining Walls

Typical FACE Fix Post to Timber Retaining Wall - M10 Coachscrews

Max Dimensions	mm
Max Height - From Top Rail to Top of Infill Panel	1200
Max Post centres	1200

General Notes:

- 1- All dimensions mm
- 2 - Conforms to NZ building Code and AS/NZ1170 regulations
- 3 - Only for Residential applications up to 1200mm high (not Commercial)
- 4 - Not suitable for fixing directly to stairs without attached Handrail

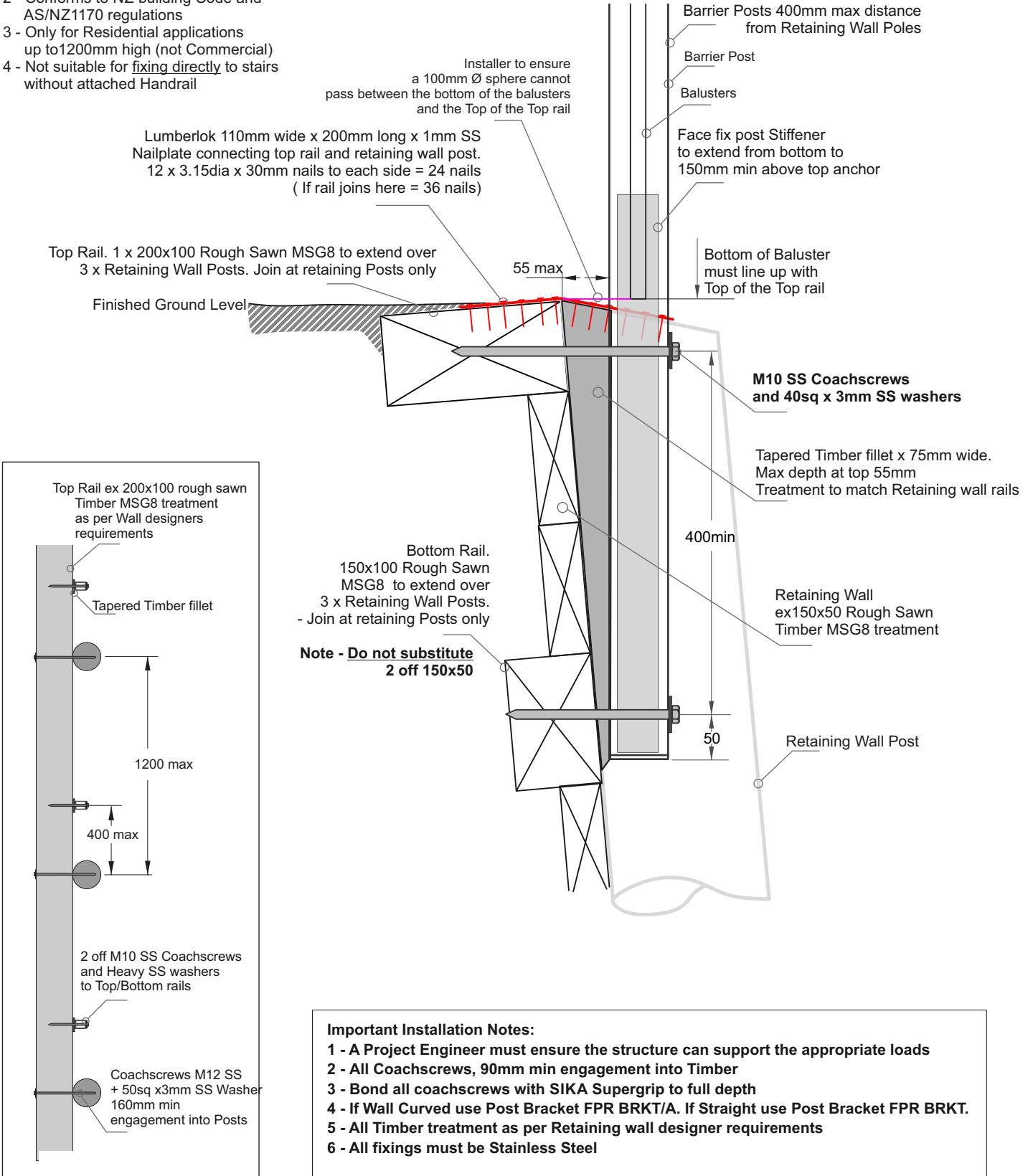

Juralco Contemporary Balustrade Systems - Typical Post Fixing For Fixing to Retaining Walls

Typical FACE Fix Post to Timber Retaining Wall - M10 Bolts

Max Dimensions	mm
Max Height - From Top Rail to Top of Infill Panel	1200
Max Post centres	1200

General Notes:

- 1- All dimensions mm
- 2 - Conforms to NZ building Code and AS/NZ1170 regulations
- 3 - Only for Residential applications up to 1200mm high (not Commercial)
- 4 - Not suitable for fixing directly to stairs without attached Handrail

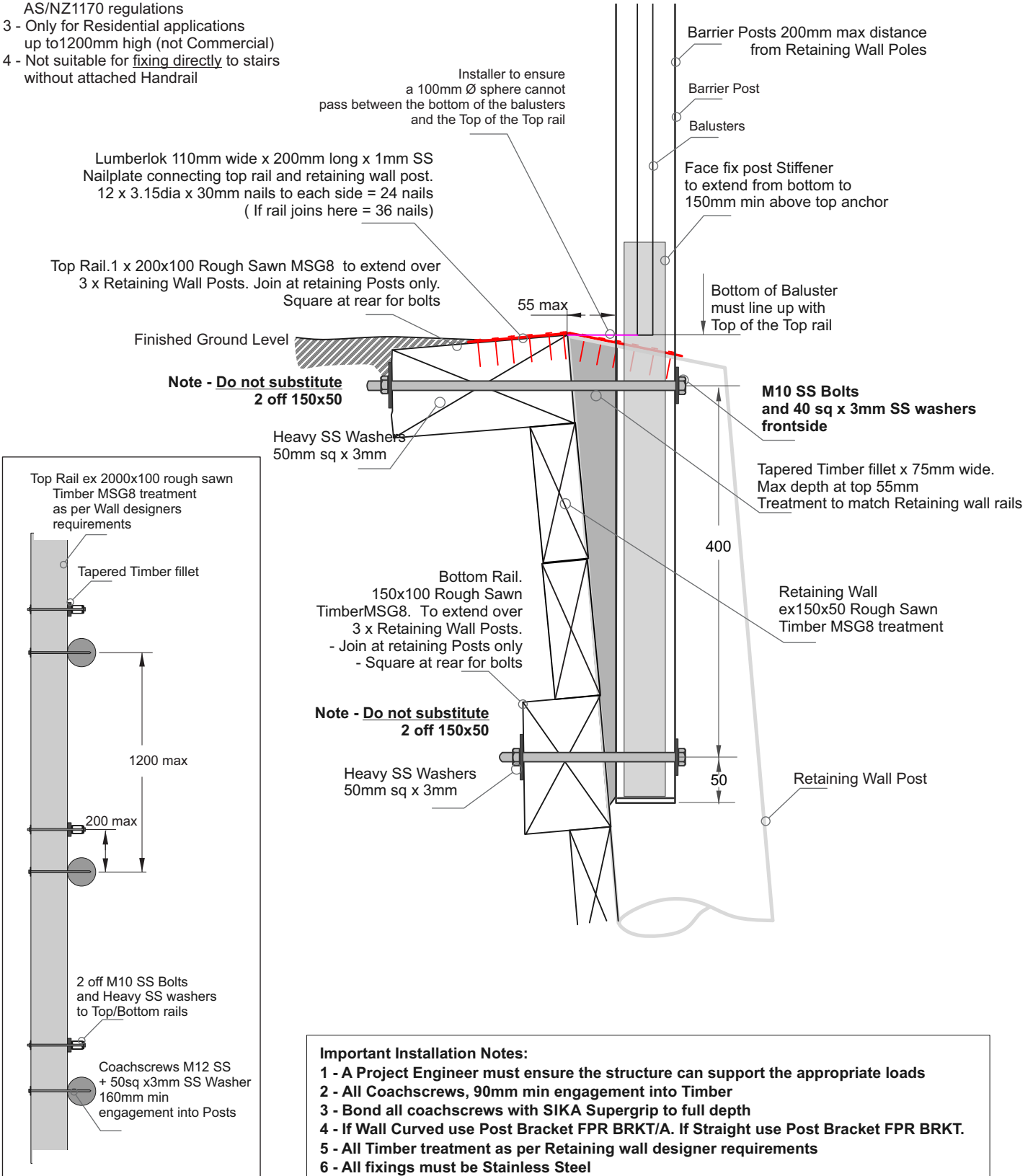

Juralco Contemporary Balustrade Systems - Typical Post Fixing For Fixing to Retaining Walls

Typical FACE Fix Post to Timber Retaining Wall - M12 Bolts

Max Dimensions	mm
Max Height - From Top Rail to Top of Infill Panel	1200
Max Post centres	1200

General Notes:

- 1- All dimensions mm
- 2 - Conforms to NZ building Code and AS/NZ1170 regulations
- 3 - Only for Residential applications up to 1200mm high (not Commercial)
- 4 - Not suitable for fixing directly to stairs without attached Handrail

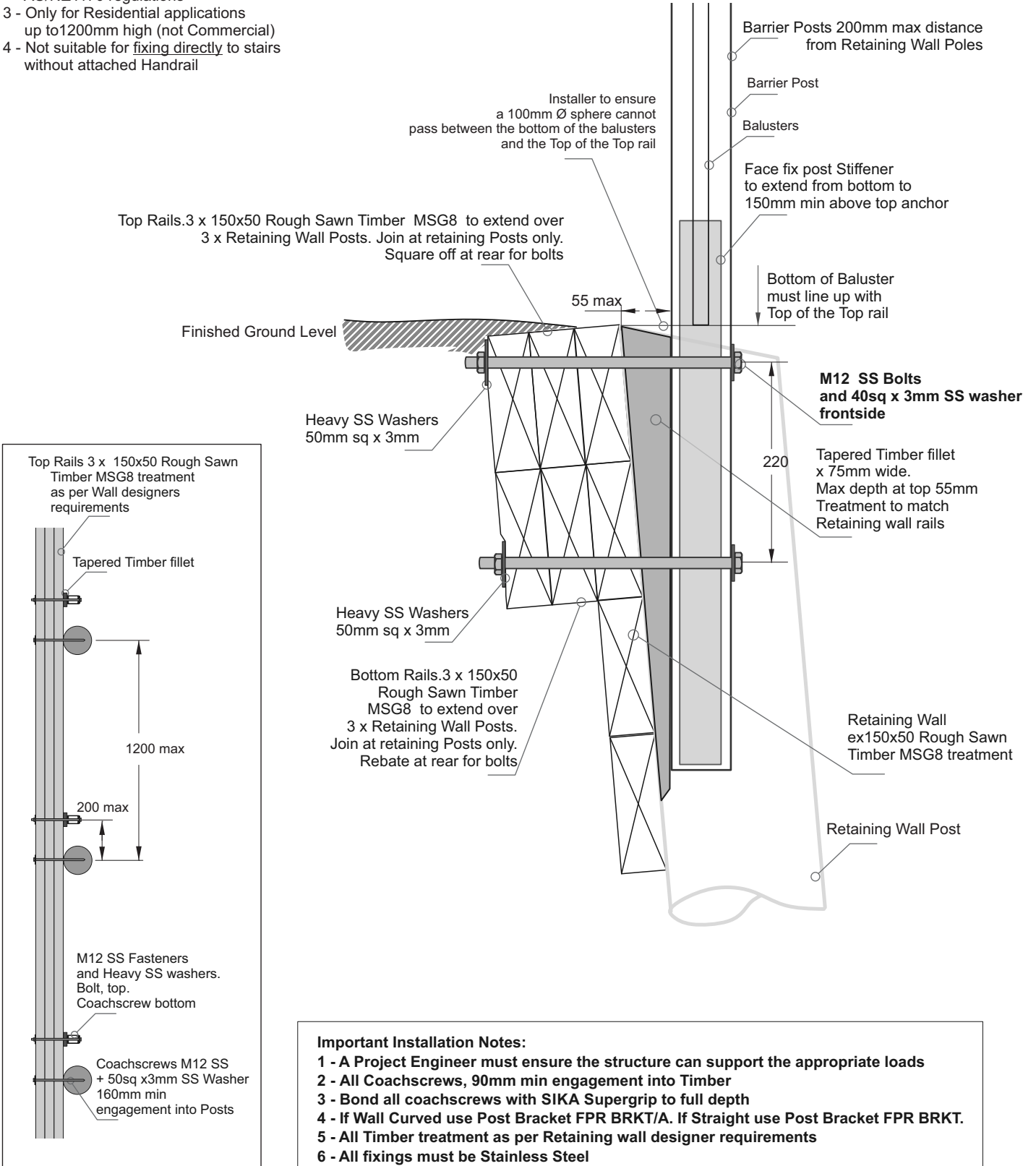

Important Installation Notes:

- 1 - A Project Engineer must ensure the structure can support the appropriate loads
- 2 - All Coachscrews, 90mm min engagement into Timber
- 3 - Bond all coachscrews with SIKA Supergrip to full depth
- 4 - If Wall Curved use Post Bracket FPR BRKT/A. If Straight use Post Bracket FPR BRKT.
- 5 - All Timber treatment as per Retaining wall designer requirements
- 6 - All fixings must be Stainless Steel

Juralco Contemporary Balustrade System - Powder Coating Care and Maintenance

Powder Coating Installation Care

Warning re use of solvents:

- In some cases strong solvents are recommended for thinning various types of paints and also for cleaning up mastics and sealants.
- These can be harmful to the extended life of the powder coated surface, and must not be used for cleaning purposes.
- It is important to note that the damage will not be visible immediately and may take up to 12 months to develop.

If paint splashes or sealants and mastics need to be removed then the following may be safely used:
Methylated Spirits, Ethyl Alcohol, Isopropanol or preferably a mild detergent in warm water.

Joinery Protection during Installation:

All the activity on a construction site means that your powder coated items may get knocked or scratched, splattered with mortar, plaster, textured coating or paint during the later stages of construction.

Please ensure that all powder coated articles are masked or covered at this time. It is far easier to prevent accidents than to try and correct them. Should your joinery receive mortar or paint splashes see that these are removed before cure and follow the instructions contained in this brochure.

Typical sticker used to warn other trades of the need to protect and mask off powder coated joinery (applies to anodised joinery also)

"IMPORTANT ALL TRADES"
This valuable aluminium joinery will suffer permanent damage from: plaster, mortar and paint splashes - Protect if splashes occur - Immediately wash down joinery with water or meths - Do not allow splashes to harden! ~ Do not use solvents! - Do not remove this label until final clean completed.

This photograph displays damage that has occurred on site, post installation. The photo of the masked joinery displays clear signs of damage that could have occurred were it not masked. Please ensure that your joinery is protected right through the entire construction process.



Powder Coating Maintenance

External - Maintenance Program:

To extend the life of external powder coated articles and to comply with warranty requirements for powder coated aluminium joinery, a simple, regular maintenance program must be implemented.

The effects of ultra violet light, atmospheric pollution, dirt, grime and airborne salt deposits will all accumulate over time and must be removed or surface staining and weathering will occur, leading to an unsightly appearance.

For external coatings, cleaning should take place every six months. In areas where pollutants are more prevalent, such as beachfront houses and industrial or geothermal areas, then a cleaning program should be carried out on a more frequent basis ie. every one to three months.

Fences or Balustrades in close proximity to swimming pools must be washed down every six months, to clean off chlorine and salt deposits.

Cleaning your powder coating:

1. Carefully remove any loose surface deposits with a wet sponge.
2. Use a soft brush (non abrasive) and a mild household detergent (do not use solvents) in warm water, remove dust, salt and other deposits.
3. Rinse off with clean fresh water.



Restoring weathered or scratched surfaces:

Repair of Scuffed or Scratched surfaces
Dulux Spray Cans are available in all colour card colours.

Repair of Small Scratches or Chips.
Dulux Dabsticks are ideally suited for the repair of small scratches.
Dabsticks may not be available in all colour card colours.

Repair of Weathered areas .
Dulux Gloss Up is a light to medium cutting cream ideally suited for gloss restoration and has been specifically designed for this purpose.
Gloss Up contains no waxes or silicone and is a one step system.



Contact Dulux Powder Coatings , ph 0064 9 441 8244

All pages © Copyright Juralco Aluminium Building Products Ltd, 2022