

# DG – Transfer and Door Grilles

## Model: DG-52 Door Grille

Offers maximum free area and is completely sight proof. Also widely used as exhaust and return air grilles where concealment of inside of duct from all angles, is desirable.

Constructed of inverted chevron shaped blades, tightly held by special spacers, in guide slots in the surround. Available in channel (flangeless) surround, or flanged frame, with or without matching back flange.

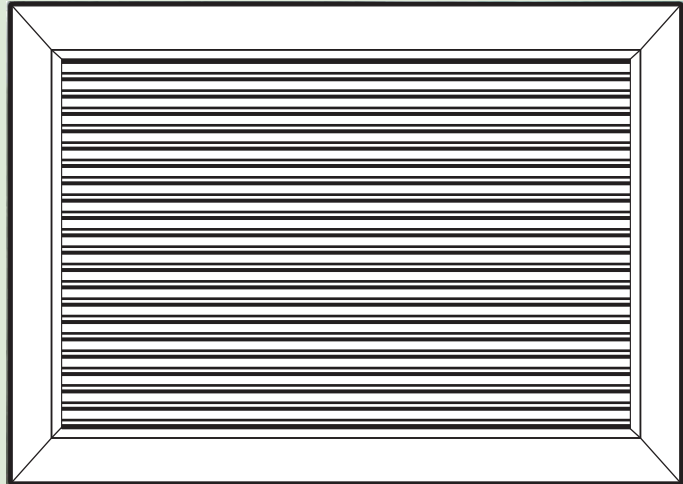

## Model: DG-17 Door Grille

Slightly less free area than DG-52. Presents an alternative architectural styling and is designed to fit sections as thin as 17mm.

Rugged, braced, extruded aluminium construction, in channel (flangeless) surround, or flanged frame, with or without matching back flange.

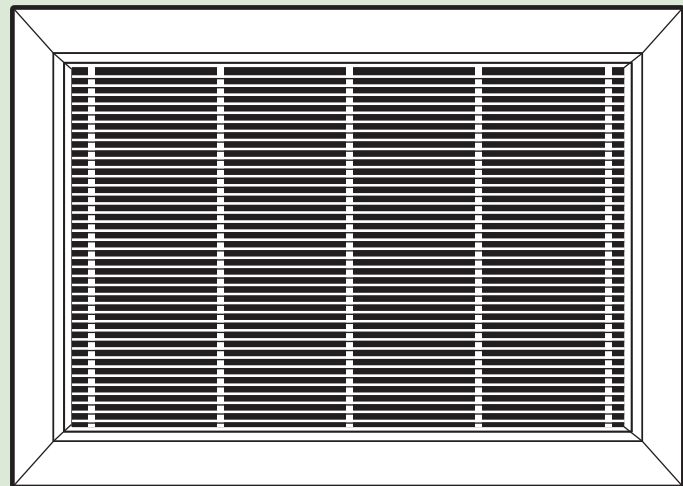

## Concealed fixing

### BFL Backing Flange

#### Concealed fixing

Where backing flanges are required, all Model DG 52 door grilles are supplied with concealed fixing clips which grip the serrated surface of the telescoping backing flange.

The face and back flanges can be used to clamp the door thickness, thus requiring no screws.

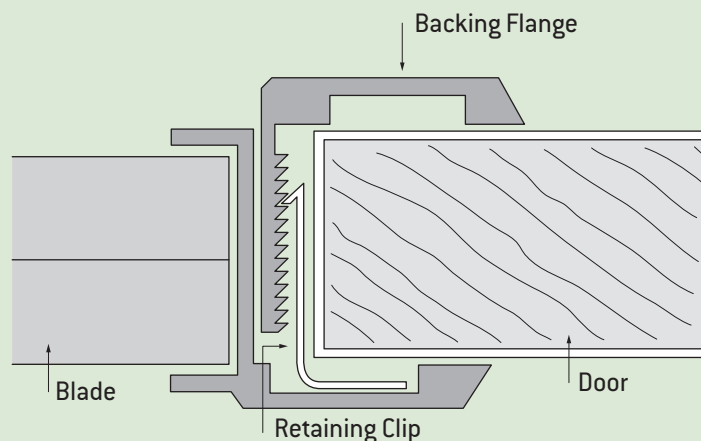

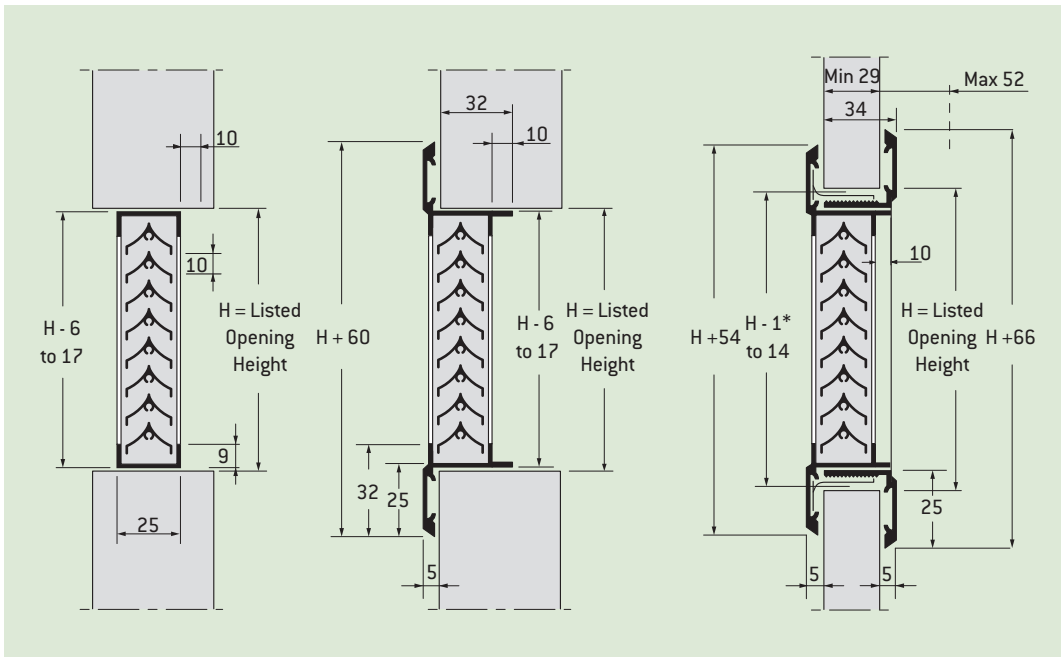

\* Core height is governed by multiples of blade height. Any difference between core height and nominal opening height is accommodated in the clearance dimension which may vary between 1 & 14mm.

Blades normally run in long dimension. Short blades are available. When ordering use suffix 'L' or 'S' respectively. e.g. DG-52-BFL.

Model: **DG-52-AL** - with channel frame. Constructed of extruded aluminium. Long blades.  
Model: **DG-52-AS** - as above, but with short blades.

Model: **DG-52-BL** - with flange frame, Long blades.  
Model: **DG-52-BS** - as above, but with short blades.

Model: **DG-52-BFL** - with flange, auxiliary frame and concealed fixing. Adjusts to fit door thickness giving finished appearance for both sides of door. Long blades.  
Model: **DG-52-BFS** - as above, but with short blades.

## Series DG17 and DG1700

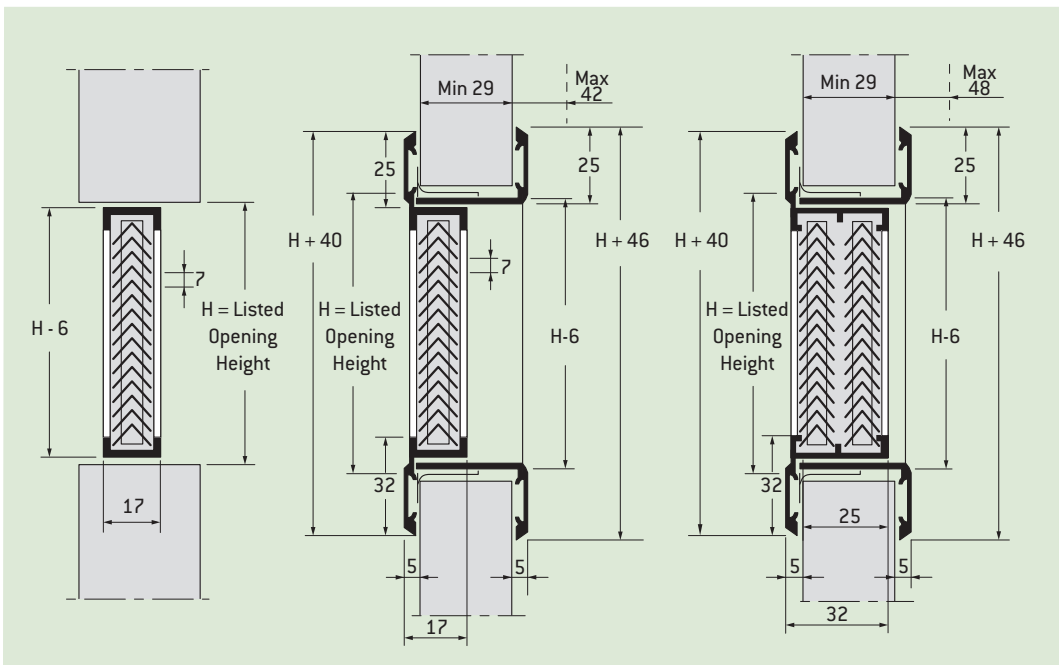

Model: **DG-17-AL** - with channel frame. Constructed of extruded aluminium.  
Model: **DG-17-AS** - as above but, with short blades.

Model: **DG-17-BFL** - with flange and backing frame. Adjusts grille to fit varying door thicknesses, giving installation finished appearances from both sides of door, or partition.  
Model: **DG-17-BL** - with flange frame and long blades.  
Model: **DG-17-BFS & DG-17-BS** - as above, but with short blades.

Model: **DG-1700-BFL** - a double thickness light proof door grille with flange and backing frame. Adjusts grille to fit varying door thicknesses, giving installation finished appearance for both sides of door, or partition.  
Model: **DG-1700-BFS** - as above, but with short blades.

Guide Product Weights	
Approximate Weight in Kg.	
Size	DG52
300 x 200	1.01
300 x 300	1.35
400 x 300	1.73
500 x 300	2.12
500 x 400	2.63
600 x 600	4.34
DG17	*
DG1700	*
*Contact your local Holyoake Branch	

Models: **DG-52**, **DG-17** and **DG-1700**

CORE AREA m <sup>2</sup>	NOMINAL SIZE(mm)	CORE VEL. m/s	NC 20				NC 30			NC 40			
			0.73	0.87	1.02	1.28	1.53	1.79	2.04	2.55	3.06	3.57	
			VEL. PRESS	0.5	0.5	1	1	2	2	3	4	6	8
		NEG. SP	8	12	15	24	33	47	60	91	129	177	
0.014	175 x 100	m <sup>3</sup> /s	0.010	0.012	0.014	0.017	0.021	0.025	0.028	0.035	0.042	0.050	
	150 x 125	NC	-	-	12	18	24	28	32	39	44	49	
0.017	200 x 100 150 x 150	m <sup>3</sup> /s	0.013	0.015	0.017	0.021	0.025	0.030	0.034	0.042	0.051	0.059	
	175 x 125	NC	-	-	13	18	24	28	33	39	45	49	
0.020	250 x 100 175 x 150	m <sup>3</sup> /s	0.015	0.018	0.021	0.026	0.031	0.036	0.042	0.052	0.062	0.073	
	200 x 125	NC	-	-	13	19	25	29	34	40	46	50	
0.024	300 x 100 200 x 150	m <sup>3</sup> /s	0.018	0.021	0.025	0.031	0.037	0.043	0.049	0.061	0.074	0.086	
	250 x 125	NC	-	10	14	20	26	30	34	41	46	51	
0.028	350 x 100	m <sup>3</sup> /s	0.021	0.025	0.028	0.035	0.042	0.050	0.057	0.071	0.085	0.099	
		NC	-	10	15	20	26	30	35	41	47	51	
0.032	400 x 100 250 x 150	m <sup>3</sup> /s	0.024	0.029	0.032	0.040	0.048	0.056	0.064	0.080	0.096	0.112	
	300 x 125	NC	-	11	15	21	27	31	35	42	47	52	
0.036	450 x 100 300 x 150	m <sup>3</sup> /s	0.027	0.032	0.037	0.046	0.055	0.065	0.074	0.092	0.110	0.129	
	350 x 125 200 x 200	NC	-	12	16	22	28	32	36	42	48	52	
0.043	500 x 100 350 x 150	m <sup>3</sup> /s	0.032	0.038	0.043	0.054	0.065	0.076	0.087	0.109	0.130	0.152	
	400 x 125 250 x 200	NC	-	12	16	22	28	32	37	43	48	53	
0.048	600 x 100 400 x 150	m <sup>3</sup> /s	0.036	0.043	0.049	0.061	0.074	0.086	0.098	0.123	0.147	0.172	
	450 x 125	NC	-	13	17	23	29	33	37	44	49	53	
0.056	700 x 100 450 x 150 250 x 250	m <sup>3</sup> /s	0.042	0.050	0.057	0.071	0.085	0.099	0.113	0.142	0.170	0.198	
	500 x 125 300 x 200	NC	-	13	17	23	29	33	38	44	50	54	
0.064	750 x 100 500 x 150 300 x 250	m <sup>3</sup> /s	0.048	0.057	0.065	0.082	0.098	0.114	0.130	0.163	0.195	0.228	
	600 x 125 350 x 200	NC	-	14	18	24	30	34	38	45	50	55	
0.075	900 x 100 550 x 150 350 x 250	m <sup>3</sup> /s	0.056	0.067	0.076	0.095	0.115	0.134	0.153	0.191	0.229	0.268	
	700 x 125 400 x 200	NC	-	14	18	24	30	34	39	45	51	55	
0.084	750 x 125 450 x 200 300 x 300	m <sup>3</sup> /s	0.062	0.075	0.085	0.106	0.127	0.149	0.170	0.212	0.255	0.297	
	650 x 150 400 x 250	NC	-	15	19	25	31	35	39	46	51	56	
0.099	900 x 125 450 x 250	m <sup>3</sup> /s	0.073	0.088	0.101	0.126	0.151	0.176	0.202	0.252	0.303	0.353	
	750 x 150 350 x 300	NC	-	15	20	25	31	35	40	46	52	56	
0.110	850 x 150 500 x 250 350 x 350	m <sup>3</sup> /s	0.082	0.098	0.111	0.139	0.167	0.195	0.223	0.278	0.334	0.390	
	600 x 200 400 x 300	NC	10	16	20	26	32	36	40	47	52	57	
0.124	900 x 150 400 x 350	m <sup>3</sup> /s	0.092	0.110	0.126	0.158	0.190	0.221	0.253	0.316	0.379	0.443	
	450 x 300	NC	10	16	20	26	32	36	41	47	53	57	
0.149	850 x 175 600 x 250 450 x 350	m <sup>3</sup> /s	0.111	0.133	0.151	0.189	0.227	0.264	0.302	0.378	0.453	0.529	
	750 x 200 500 x 300 400 x 400	NC	11	17	21	27	33	37	41	48	53	58	
0.167	900 x 200 600 x 300 450 x 400	m <sup>3</sup> /s	0.124	0.149	0.170	0.212	0.255	0.297	0.340	0.425	0.510	0.595	
	750 x 250 500 x 350	NC	11	17	22	27	33	37	42	48	54	58	
0.183	900 x 250 600 x 350 450 x 450	m <sup>3</sup> /s	0.136	0.163	0.196	0.245	0.294	0.344	0.393	0.491	0.589	0.687	
	750 x 300 500 x 400	NC	12	18	22	28	34	38	42	49	54	59	
0.228	800 x 300 600 x 400	m <sup>3</sup> /s	0.169	0.203	0.231	0.289	0.347	0.404	0.462	0.578	0.694	0.809	
	650 x 350 500 x 450	NC	13	19	23	29	35	39	43	50	55	60	
0.258	900 x 300 650 x 400	m <sup>3</sup> /s	0.192	0.230	0.262	0.328	0.394	0.459	0.525	0.656	0.787	0.918	
	750 x 350 600 x 450	NC	13	19	23	29	35	39	44	50	56	60	
0.289	900 x 350 650 x 450	m <sup>3</sup> /s	0.215	0.257	0.294	0.367	0.440	0.513	0.587	0.734	0.881	1.030	
	750 x 400 600 x 500	NC	14	20	24	30	36	40	44	51	56	60	
0.335	900 x 400 600 x 600	m <sup>3</sup> /s	0.249	0.298	0.341	0.426	0.511	0.596	0.681	0.852	1.020	1.190	
	750 x 450	NC	14	20	24	30	36	40	45	51	57	61	
0.399	900 x 450	m <sup>3</sup> /s	0.296	0.355	0.405	0.506	0.607	0.708	0.810	1.010	1.220	1.420	
	800 x 500	NC	15	21	25	31	37	41	45	52	57	62	
0.432	900 x 500	m <sup>3</sup> /s	0.321	0.385	0.439	0.548	0.658	0.768	0.878	1.090	1.320	1.540	
	750 x 600	NC	15	21	25	31	37	41	46	52	58	62	
0.518	900 x 600	m <sup>3</sup> /s	0.385	0.461	0.527	0.658	0.790	0.922	1.050	1.320	1.580	1.840	

NC 50

NC 60

Return & Exhaust Grilles

TYPE	CORRECTION FACTOR	
	NC	SP
DG-52	+0	x 1.0
DG-17	+5	x 1.4
DG-1700	+7	x 2.8

- Neg. SP is negative static pressure.
- NC values are based on room absorption of 10 db, re 10<sup>-12</sup> watts.

- All pressures are in Pascals.
- Heavy dividing lines denote ranges of NC values.